

General Description

The ICS83PN625I is a programmable LVPECL synthesizer that is “forward” footprint compatible with standard 5mm x 7mm oscillators. The device uses IDT’s fourth generation FemtoClock® NG technology for an optimum of high clock frequency and low phase noise performance. Forward footprint compatibility means that a board designed to accommodate the crystal oscillator interface and the optional control pins is also fully compatible with a canned oscillator footprint - the canned oscillator will drop onto the 10-VFQFN footprint for second sourcing purposes. This capability provides designers with programability and lead time advantages of silicon/crystal based solutions while maintaining compatibility with industry standard 5mm x 7mm oscillator footprints for ease of supply chain management. Oscillator-level performance is maintained with IDT’s 4th Generation FemtoClock® NG PLL technology, which delivers sub 0.5ps rms phase jitter.

The ICS83PN625I defaults to 312.5MHz using a 25MHz crystal with 2 programming pins floating (pulled down/pulled up with internal pullup or pulldown resistors) but can also be set to 4 different frequency multiplier settings to support a wide variety of applications. The below table shows some of the more common application settings.

Frequency Select Table

FSEL[1:0]	XTAL (MHz)	Output Frequency (MHz)	Common Application(s)
00	25	156.25	10 Gigabit Ethernet XAU1
01	25	625	10 Gigabit Ethernet, XAU1
10	25	250	Ethernet, Infiniband
11 (default)	25	312.5	10 Gigabit Ethernet XAU1, Rocket IO

Block Diagram

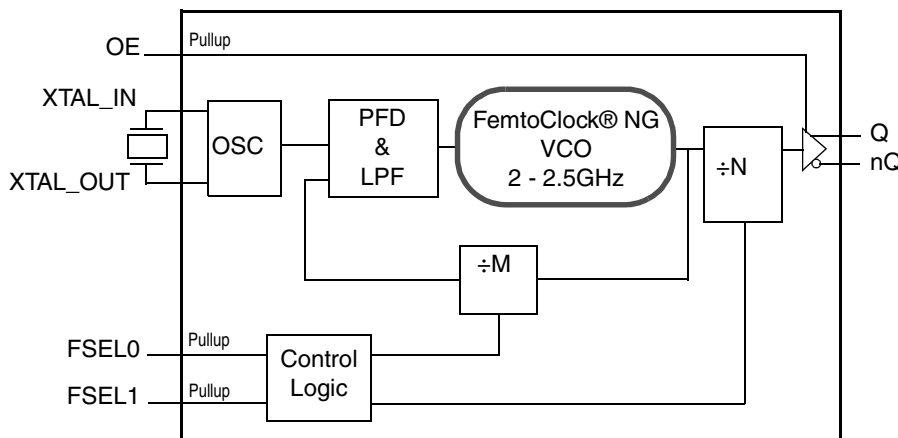

Features

- Fourth Generation FemtoClock® Next Generation (NG) technology
- Footprint compatible with 5mm x 7mm differential oscillators
- One differential LVPECL output pair
- Crystal oscillator interface which can be overdriven by a single-ended reference clock
- Output frequency range: 125MHz – 625MHz
- Crystal/input frequency range: 25MHz, parallel resonant crystal
- VCO range: 2GHz – 2.5GHz
- Cycle-to-cycle jitter: 10ps (maximum), @ 3.3V±5%
- RMS phase jitter @ 156.25MHz, 12kHz – 20MHz: 0.348ps (typical)
- Full 3.3V or 2.5V operating supply
- -40°C to 85°C ambient operating temperature
- Available in a lead-free (RoHS 6) package

Pin Assignment

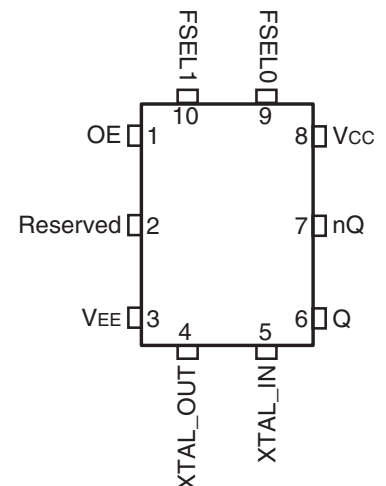

ICS83PN625I
10-Lead VFQFN
5mm x 7mm x 1mm package body
K Package
Top View

Table 1. Pin Descriptions

Number	Name	Type		Description
1	OE		Pullup	Output enable. External pullup required for normal operation. LVCMOS/LVTTL interface levels.
2	Reserved	Reserve		Reserved pin. Do not connect
3	V _{EE}	Power		Negative supply pin.
4, 5	XTAL_OUT XTAL_IN	Input		Crystal oscillator interface XTAL_IN is the input, XTAL_OUT is the output. This oscillator interface can also be driven by a single-ended reference clock.
6, 7	Q, nQ	Output		Differential output pair. LVPECL interface levels.
8	V _{CC}	Power		Power supply pin.
9	FSEL0	Input	Pullup	Output frequency select pin. Sets the output divider value to one of four values. LVCMOS/LVTTL interface levels. See <i>Frequency Select Table</i> on page 1.
10	FSEL1	Input	Pullup	Output frequency select pin. Sets the output divider value to one of four values. LVCMOS/LVTTL interface levels. See <i>Frequency Select Table</i> on page 1.

NOTE: *Pullup* refers to internal input resistors. See Table 2, *Pin Characteristics*, for typical values.

Table 2. Pin Characteristics

Symbol	Parameter	Test Conditions	Minimum	Typical	Maximum	Units
C _{IN}	Input Capacitance			4		pF
R _{PULLUP}	Input Pullup Resistor			51		kΩ

Function Table**Table 3. Divider Function Table**

FSEL[1:0]	M Value	N Value
0 0	100	÷16
0 1	100	÷4
1 0	80	÷8
1 1 (default)	100	÷8

Absolute Maximum Ratings

NOTE: Stresses beyond those listed under *Absolute Maximum Ratings* may cause permanent damage to the device. These ratings are stress specifications only. Functional operation of product at these conditions or any conditions beyond those listed in the *DC Characteristics* or *AC Characteristics* is not implied. Exposure to absolute maximum rating conditions for extended periods may affect product reliability.

Item	Rating
Supply Voltage, V_{CC}	3.63V
Inputs, V_I XTAL_IN Other Inputs	0V to 2V -0.5V to $V_{CC} + 0.5V$
Outputs, I_O Continuous Current Surge Current	50mA 100mA
Package Thermal Impedance, θ_{JA}	39.2°C/W (0 mps)
Storage Temperature, T_{STG}	-65°C to 150°C

DC Electrical Characteristics

Table 4A. Power Supply DC Characteristics, $V_{CC} = 3.3V \pm 5\%$, $V_{EE} = 0V$, $T_A = -40^\circ C$ to $85^\circ C$

Symbol	Parameter	Test Conditions	Minimum	Typical	Maximum	Units
V_{CC}	Power Supply Voltage		3.135	3.3	3.465	V
I_{EE}	Power Supply Current				131	mA

Table 4B. Power Supply DC Characteristics, $V_{CC} = 2.5V \pm 5\%$, $V_{EE} = 0V$, $T_A = -40^\circ C$ to $85^\circ C$

Symbol	Parameter	Test Conditions	Minimum	Typical	Maximum	Units
V_{CC}	Power Supply Voltage		2.375	2.5	2.625	V
I_{EE}	Power Supply Current				124	mA

Table 4C. LVCMOS/LVTTL DC Characteristics, $V_{CC} = 3.3V \pm 5\%$ or $2.5V \pm 5\%$, $V_{EE} = 0V$, $T_A = -40^\circ C$ to $85^\circ C$

Symbol	Parameter	Test Conditions	Minimum	Typical	Maximum	Units
V_{IH}	Input High Voltage	$V_{CC} = 3.465V$	2		$V_{CC} + 0.3$	V
		$V_{CC} = 2.625V$	1.7		$V_{CC} + 0.3$	V
V_{IL}	Input Low Voltage	$V_{CC} = 3.465V$	-0.3		0.8	V
		$V_{CC} = 2.625V$	-0.3		0.7	V
I_{IH}	Input High Current	FSEL[1:0] $V_{CC} = V_{IN} = 3.465V$ or $2.625V$			5	μA
I_{IL}	Input Low Current	FSEL[1:0] $V_{CC} = 3.465V$ or $2.625V$, $V_{IN} = 0V$	-150			μA

Table 4D. LVPECL DC Characteristics, $V_{CC} = 3.3V \pm 5\%$ or $2.5V \pm 5\%$, $V_{EE} = 0V$, $T_A = -40^{\circ}C$ to $85^{\circ}C$

Symbol	Parameter	Test Conditions	Minimum	Typical	Maximum	Units
V_{OH}	Output High Voltage; NOTE 1		$V_{CC} - 1.3$		$V_{CC} - 0.8$	V
V_{OL}	Output Low Voltage; NOTE 1		$V_{CC} - 2.0$		$V_{CC} - 1.6$	V
V_{SWING}	Peak-to-Peak Output Voltage Swing		0.6		1.0	V

NOTE 1: Outputs termination with 50Ω to $V_{CC} - 2V$.

Table 5. Crystal Characteristics

Parameter	Test Conditions	Minimum	Typical	Maximum	Units
Mode of Oscillation		Fundamental			
Frequency		20		25	MHz
Equivalent Series Resistance (ESR)				50	Ω
Shunt Capacitance				7	pF

AC Electrical Characteristics

Table 6A. AC Characteristics, $V_{CC} = 3.3V \pm 5\%$, $V_{EE} = 0V$, $T_A = -40^\circ C$ to $85^\circ C$

Symbol	Parameter	Test Conditions	Minimum	Typical	Maximum	Units
f_{MAX}	Output Frequency		156.25		625	MHz
$f_{jit}(cc)$	Cycle-to-Cycle Jitter; NOTE 1				10	ps
$f_{jit}(\emptyset)$	RMS Phase Jitter (Random); NOTE 2	156.25MHz, Integration Range: 12kHz – 20MHz		0.348	0.5	ps
		250MHz, Integration Range: 12kHz – 20MHz		0.305	0.5	ps
		312.5MHz, Integration Range: 12kHz – 20MHz		0.338	0.5	ps
		625MHz, Integration Range: 12kHz – 20MHz		0.343	0.5	ps
t_R / t_F	Output Rise/Fall Time	20% to 80%	100		350	ps
odc	Output Duty Cycle		47		53	%

NOTE: Electrical parameters are guaranteed over the specified ambient operating temperature range, which is established when the device is mounted in a test socket with maintained transverse airflow greater than 500 lfm. The device will meet specifications after thermal equilibrium has been reached under these conditions.

NOTE: Characterized using a 25MHz, 12pF resonant crystal.

NOTE: Characterized using a crystal.

NOTE 1: This parameter is defined in accordance with JEDEC Standard 65.

NOTE 2: Please refer to the Phase Noise plots.

Table 6B. AC Characteristics, $V_{CC} = 2.5V \pm 5\%$, $V_{EE} = 0V$, $T_A = -40^\circ C$ to $85^\circ C$

Symbol	Parameter	Test Conditions	Minimum	Typical	Maximum	Units
f_{MAX}	Output Frequency		156.25		625	MHz
$f_{jit}(cc)$	Cycle-to-Cycle Jitter; NOTE 1				12	ps
$f_{jit}(\emptyset)$	RMS Phase Jitter (Random); NOTE 2	156.25MHz, Integration Range: 12kHz – 20MHz		0.359	0.5	ps
		250MHz, Integration Range: 12kHz – 20MHz		0.315	0.5	ps
		312.5MHz, Integration Range: 12kHz – 20MHz		0.349	0.5	ps
		625MHz, Integration Range: 12kHz – 20MHz		0.351	0.5	ps
t_R / t_F	Output Rise/Fall Time	20% to 80%	100		350	ps
odc	Output Duty Cycle		46		54	%

NOTE: Electrical parameters are guaranteed over the specified ambient operating temperature range, which is established when the device is mounted in a test socket with maintained transverse airflow greater than 500 lfm. The device will meet specifications after thermal equilibrium has been reached under these conditions.

NOTE: Characterized using a 25MHz, 12pF resonant crystal.

NOTE: Characterized using a crystal.

NOTE 1: This parameter is defined in accordance with JEDEC Standard 65.

NOTE 2: Please refer to the Phase Noise plots.

Typical Phase Noise at 156.25MHz (3.3V)

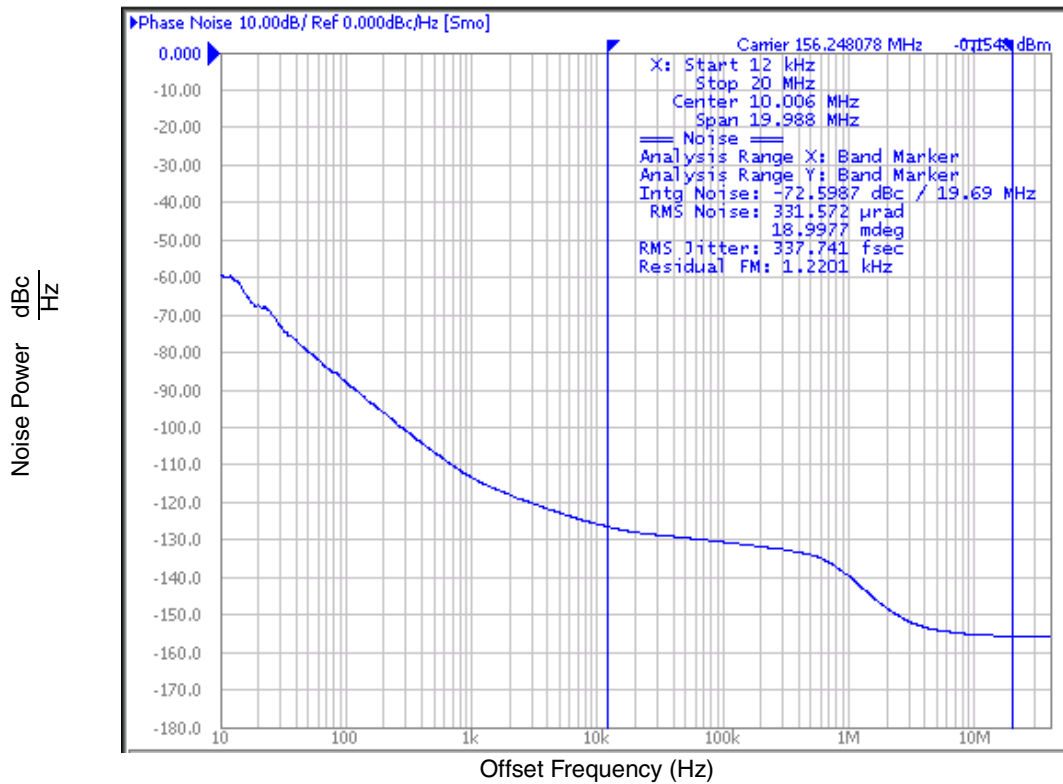

Typical Phase Noise at 312.5MHz (3.3V)

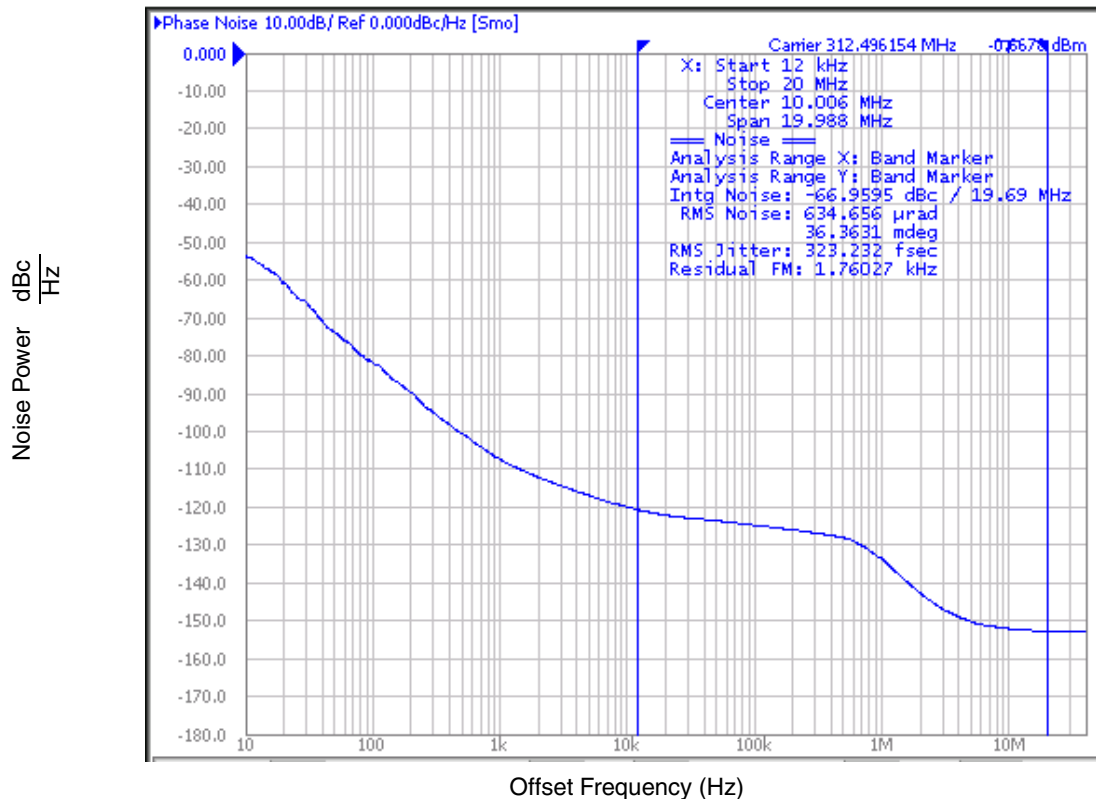

Parameter Measurement Information

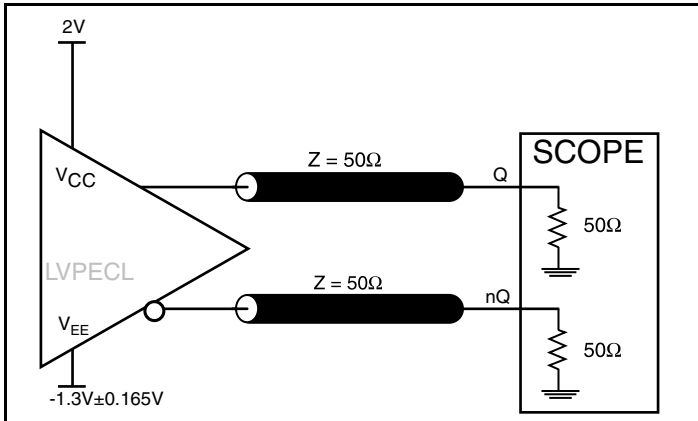

3.3V LVPECL Output Load AC Test Circuit

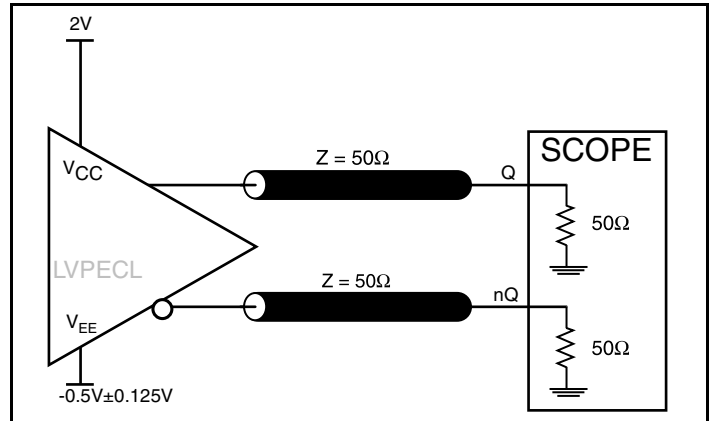

2.5V LVPECL Output Load AC Test Circuit

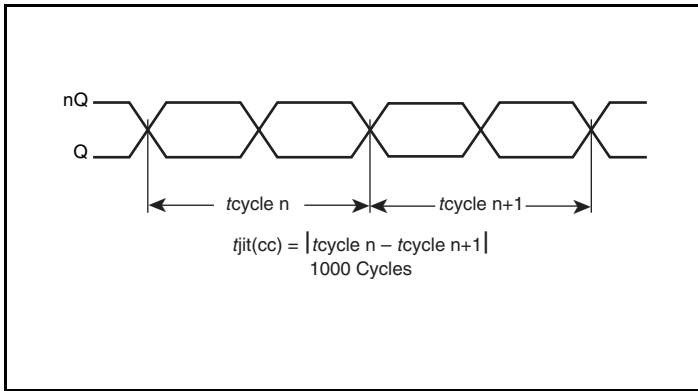

Cycle-to-Cycle Jitter

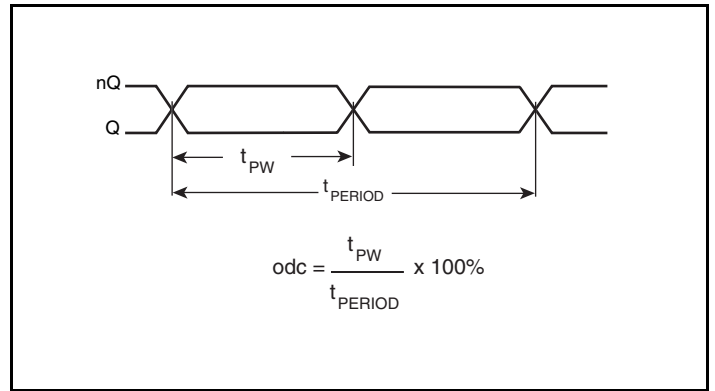

Output Duty Cycle/Pulse Width/Period

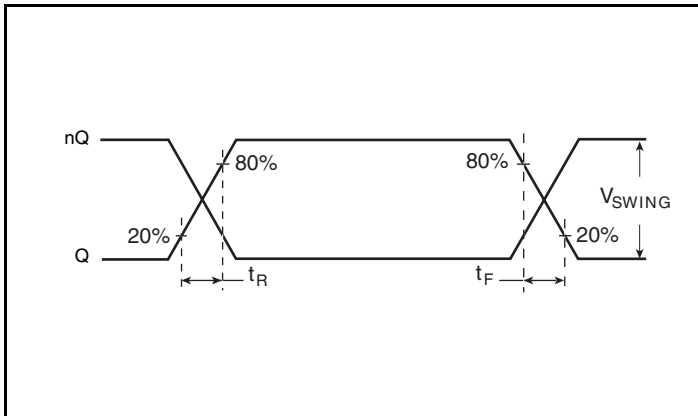

Output Rise/Fall Time

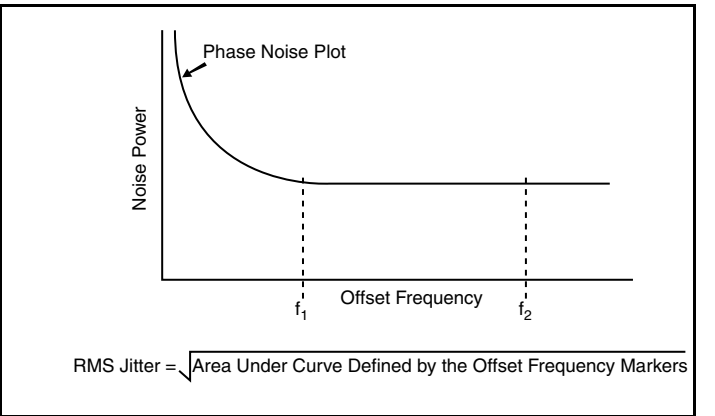

RMS Phase Jitter

Application Information

Recommendations for Unused Input Pins

Inputs:

LVC MOS Control Pins

All control pins have internal pullups; additional resistance is not required but can be added for additional protection. A 1k Ω resistor can be used.

VFQFN EPAD Thermal Release Path

In order to maximize both the removal of heat from the package and the electrical performance, a land pattern must be incorporated on the Printed Circuit Board (PCB) within the footprint of the package corresponding to the exposed metal pad or exposed heat slug on the package, as shown in *Figure 1*. The solderable area on the PCB, as defined by the solder mask, should be at least the same size/shape as the exposed pad/slug area on the package to maximize the thermal/electrical performance. Sufficient clearance should be designed on the PCB between the outer edges of the land pattern and the inner edges of pad pattern for the leads to avoid any shorts.

While the land pattern on the PCB provides a means of heat transfer and electrical grounding from the package to the board through a solder joint, thermal vias are necessary to effectively conduct from the surface of the PCB to the ground plane(s). The land pattern must be connected to ground through these vias. The vias act as “heat pipes”. The number of vias (i.e. “heat pipes”) are application specific

and dependent upon the package power dissipation as well as electrical conductivity requirements. Thus, thermal and electrical analysis and/or testing are recommended to determine the minimum number needed. Maximum thermal and electrical performance is achieved when an array of vias is incorporated in the land pattern. It is recommended to use as many vias connected to ground as possible. It is also recommended that the via diameter should be 12 to 13mils (0.30 to 0.33mm) with 1 oz copper via barrel plating. This is desirable to avoid any solder wicking inside the via during the soldering process which may result in voids in solder between the exposed pad/slug and the thermal land. Precautions should be taken to eliminate any solder voids between the exposed heat slug and the land pattern. Note: These recommendations are to be used as a guideline only. For further information, please refer to the Application Note on the Surface Mount Assembly of Amkor’s Thermally/Electrically Enhance Leadframe Base Package, Amkor Technology.

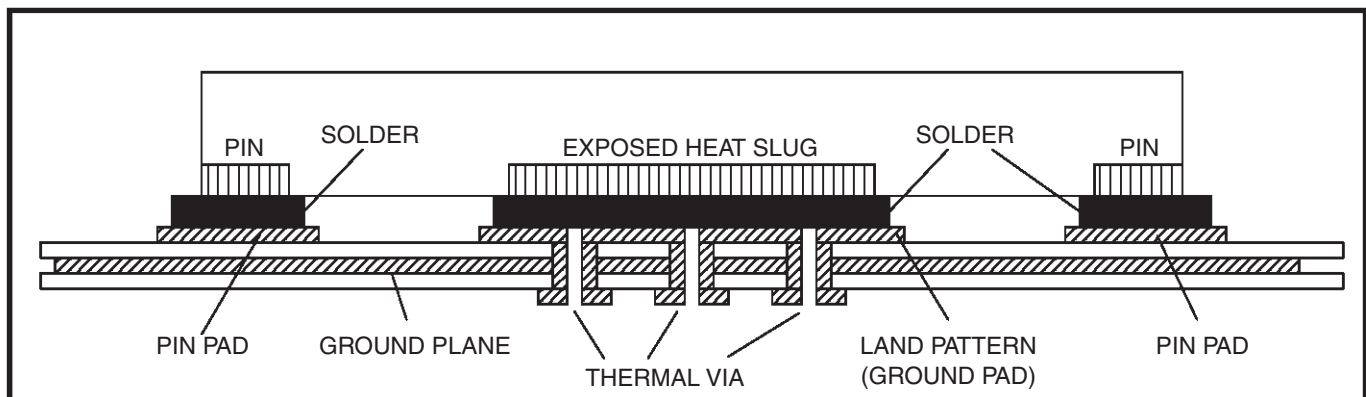

Figure 1. P.C. Assembly for Exposed Pad Thermal Release Path – Side View (drawing not to scale)

Crystal Input Interface

The ICS83PN625I has been characterized with 12pF parallel resonant crystals. The capacitor values shown in *Figure 2A* below were determined using a 25MHz, 12pF parallel resonant crystal and

were chosen to minimize the ppm error. Other parallel resonant crystal's values can be used. For example, a crystal with a $C_L = 18pF$ can be used, but would require the tuning capacitors to be adjusted.

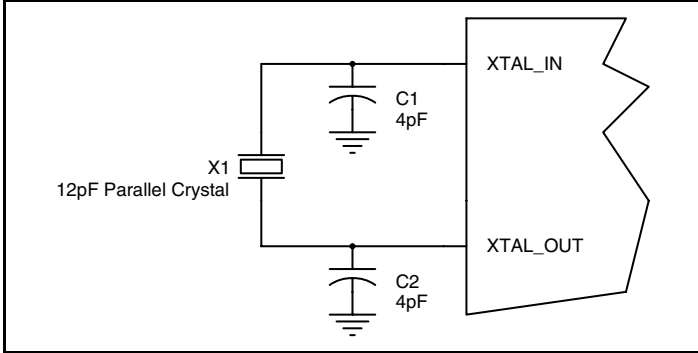

Figure 2A. Crystal Input Interface, using 12pF crystal

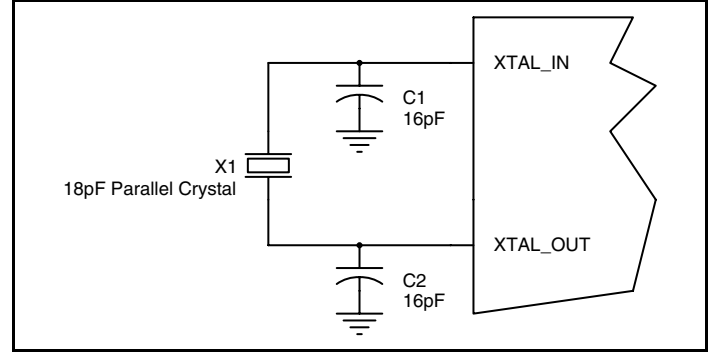

Figure 2B. Crystal Input Interface, using 18pF crystal

Overdriving the XTAL Interface

The XTAL_IN input can accept a single-ended LVCMOS signal through an AC coupling capacitor. A general interface diagram is shown in *Figure 3A*. The XTAL_OUT pin can be left floating. The maximum amplitude of the input signal should not exceed 2V and the input edge rate can be as slow as 10ns. This configuration requires that the output impedance of the driver (R_o) plus the series resistance (R_s) equals the transmission line impedance. In addition,

matched termination at the crystal input will attenuate the signal in half. This can be done in one of two ways. First, R_1 and R_2 in parallel should equal the transmission line impedance. For most 50Ω applications, R_1 and R_2 can be 100Ω. This can also be accomplished by removing R_1 and making R_2 50Ω. By overdriving the crystal oscillator, the device will be functional, but note, the device performance is guaranteed by using a quartz crystal.

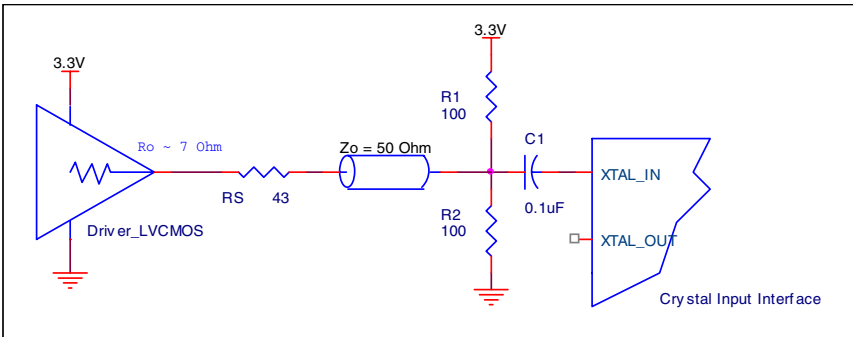

Figure 3A. General Diagram for LVCMOS Driver to XTAL Input Interface

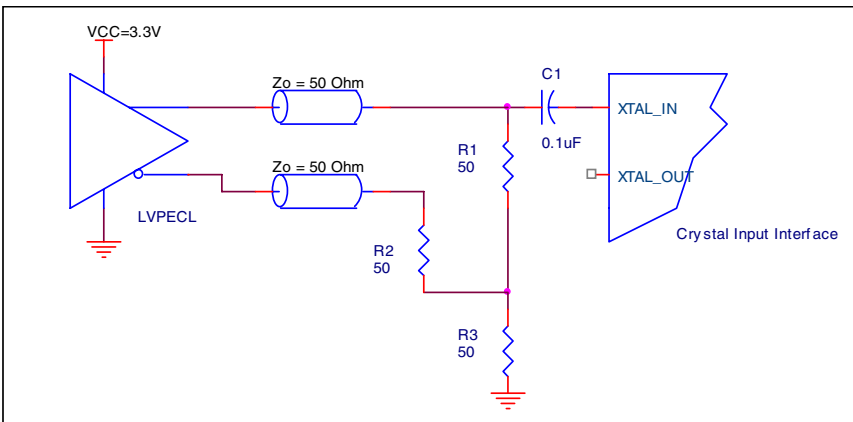

Figure 3B. General Diagram for LVPECL Driver to XTAL Input Interface

Termination for 3.3V LVPECL Outputs

The clock layout topology shown below is a typical termination for LVPECL outputs. The two different layouts mentioned are recommended only as guidelines.

The differential output is low impedance follower outputs that generate ECL/LVPECL compatible outputs. Therefore, terminating resistors (DC current path to ground) or current sources must be used for functionality. These outputs are designed to drive 50Ω

transmission lines. Matched impedance techniques should be used to maximize operating frequency and minimize signal distortion.

Figures 4A and 4B show two different layouts which are recommended only as guidelines. Other suitable clock layouts may exist and it would be recommended that the board designers simulate to guarantee compatibility across all printed circuit and clock component process variations.

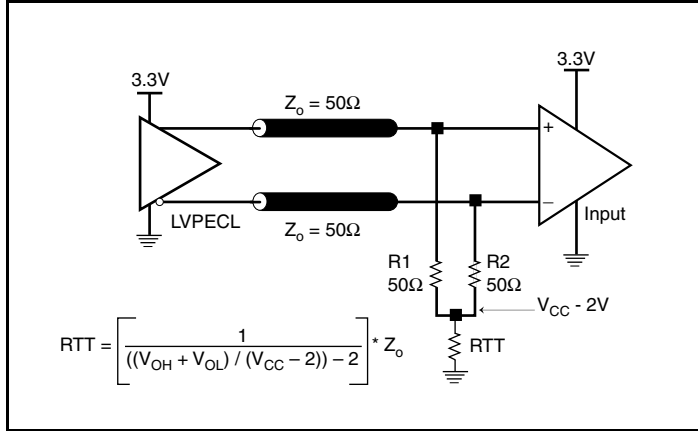

Figure 4A. 3.3V LVPECL Output Termination

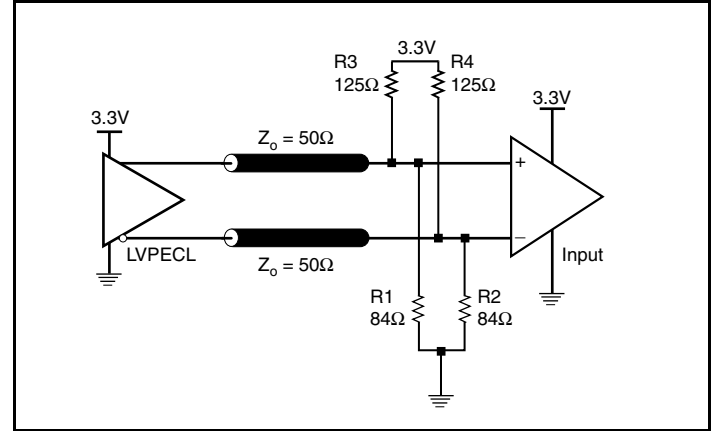

Figure 4B. 3.3V LVPECL Output Termination

Termination for 2.5V LVPECL Outputs

Figure 5A and Figure 5B show examples of termination for 2.5V LVPECL driver. These terminations are equivalent to terminating 50Ω to $V_{CC} - 2V$. For $V_{CC} = 2.5V$, the $V_{CC} - 2V$ is very close to ground

level. The R3 in Figure 5B can be eliminated and the termination is shown in Figure 5C.

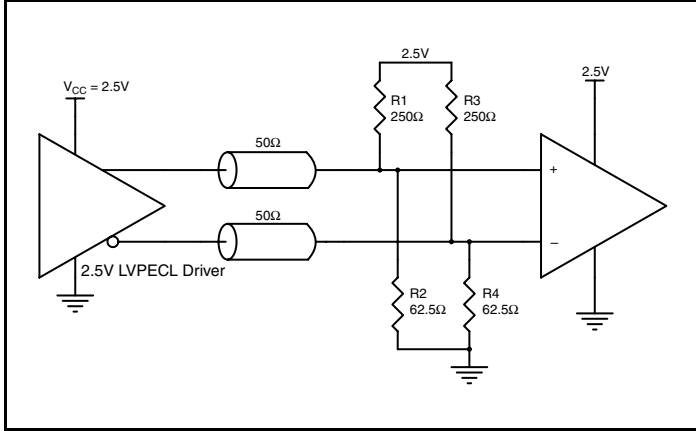

Figure 5A. 2.5V LVPECL Driver Termination Example

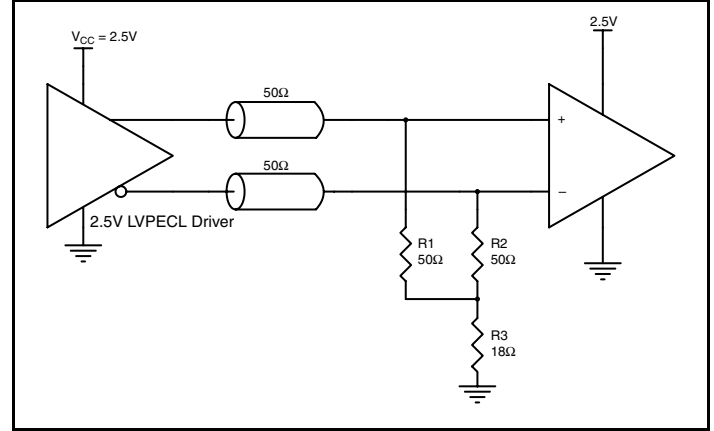

Figure 5B. 2.5V LVPECL Driver Termination Example

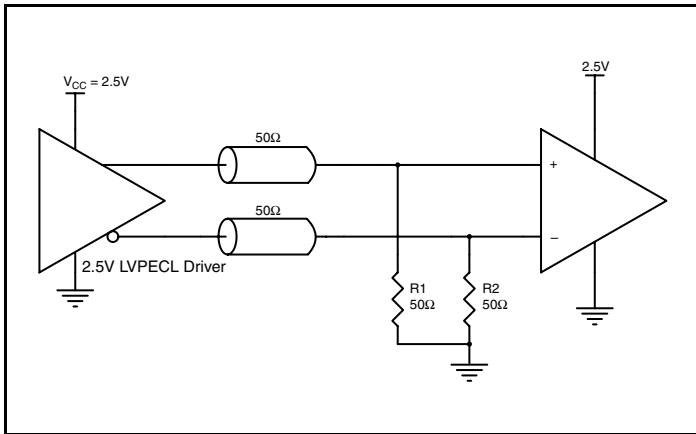

Figure 5C. 2.5V LVPECL Driver Termination Example

Power Considerations

This section provides information on power dissipation and junction temperature for the ICS83PN625I. Equations and example calculations are also provided.

1. Power Dissipation.

The total power dissipation for the ICS83PN625I is the sum of the core power plus the power dissipated in the load(s). The following is the power dissipation for $V_{CC} = 3.3V + 5\% = 3.465V$, which gives worst case results.

NOTE: Please refer to Section 3 for details on calculating power dissipated in the load.

- Power (core)_{MAX} = $V_{CC_MAX} * I_{EE_MAX} = 3.465V * 131mA = \mathbf{453.915mW}$
- Power (outputs)_{MAX} = **32mW/Loaded Output pair**

Total Power_{MAX} (3.3V, with all outputs switching) = $453.915mW + 32mW = \mathbf{485.915mW}$

2. Junction Temperature.

Junction temperature, T_j , is the temperature at the junction of the bond wire and bond pad directly affects the reliability of the device. The maximum recommended junction temperature is 125°C. Limiting the internal transistor junction temperature, T_j , to 125°C ensures that the bond wire and bond pad temperature remains below 125°C.

The equation for T_j is as follows: $T_j = \theta_{JA} * Pd_total + T_A$

T_j = Junction Temperature

θ_{JA} = Junction-to-Ambient Thermal Resistance

Pd_total = Total Device Power Dissipation (example calculation is in section 1 above)

T_A = Ambient Temperature

In order to calculate junction temperature, the appropriate junction-to-ambient thermal resistance θ_{JA} must be used. Assuming no air flow and a multi-layer board, the appropriate value is 39.2°C/W per Table 7 below.

Therefore, T_j for an ambient temperature of 85°C with all outputs switching is:

$$85^\circ\text{C} + 0.486\text{W} * 39.2^\circ\text{C/W} = 104.1^\circ\text{C}. \text{ This is well below the limit of } 125^\circ\text{C}.$$

This calculation is only an example. T_j will obviously vary depending on the number of loaded outputs, supply voltage, air flow and the type of board (multi-layer).

Table 7. Thermal Resistance θ_{JA} for 10 Lead VFQFN, Forced Convection

θ_{JA} vs. Air Flow	
Meters per Second	0
Multi-Layer PCB, JEDEC Standard Test Boards	39.2°C/W

3. Calculations and Equations.

The purpose of this section is to calculate power dissipation on the LVPECL output pair.

LVPECL output driver circuit and termination are shown in *Figure 6*.

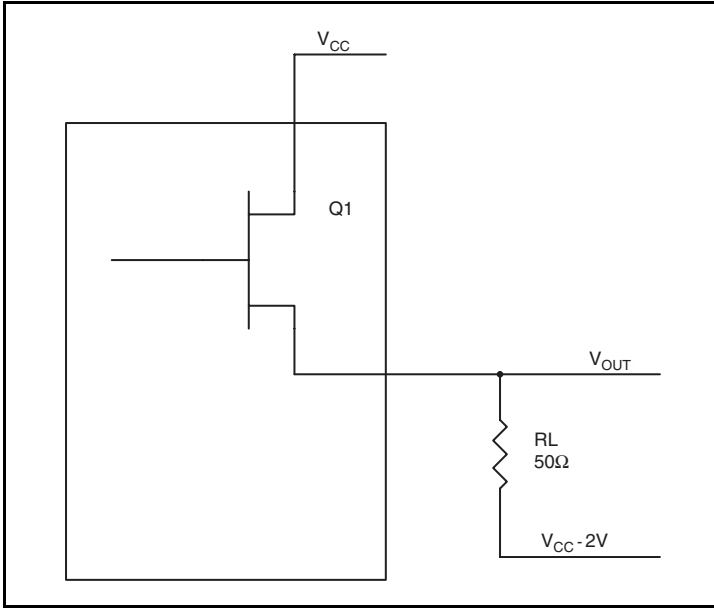

Figure 6. LVPECL Driver Circuit and Termination

To calculate worst case power dissipation into the load, use the following equations which assume a 50Ω load, and a termination voltage of $V_{CC} - 2V$.

- For logic high, $V_{OUT} = V_{OH_MAX} = V_{CC_MAX} - 0.8V$
($V_{CC_MAX} - V_{OH_MAX}$) = **0.8V**
- For logic low, $V_{OUT} = V_{OL_MAX} = V_{CC_MAX} - 1.6V$
($V_{CC_MAX} - V_{OL_MAX}$) = **1.6V**

Pd_H is power dissipation when the output drives high.

Pd_L is the power dissipation when the output drives low.

$$Pd_H = [(V_{OH_MAX} - (V_{CC_MAX} - 2V))/R_L] * (V_{CC_MAX} - V_{OH_MAX}) = [(2V - (V_{CC_MAX} - V_{OH_MAX}))/R_L] * (V_{CC_MAX} - V_{OH_MAX}) = [(2V - 0.8V)/50\Omega] * 0.8V = \mathbf{19.2mW}$$

$$Pd_L = [(V_{OL_MAX} - (V_{CC_MAX} - 2V))/R_L] * (V_{CC_MAX} - V_{OL_MAX}) = [(2V - (V_{CC_MAX} - V_{OL_MAX}))/R_L] * (V_{CC_MAX} - V_{OL_MAX}) = [(2V - 1.6V)/50\Omega] * 1.6V = \mathbf{12.82mW}$$

Total Power Dissipation per output pair = $Pd_H + Pd_L = \mathbf{32mW}$

Reliability Information

Table 8. θ_{JA} vs. Air Flow Table for a 10 Lead VFQFN

θ_{JA} vs. Air Flow	
Meters per Second	0
Multi-Layer PCB, JEDEC Standard Test Boards	39.2°C/W

Transistor Count

The transistor count for ICS83PN625I is: 25,212

Package Outline

Package Outline - K Suffix for 10-Lead VFQFN

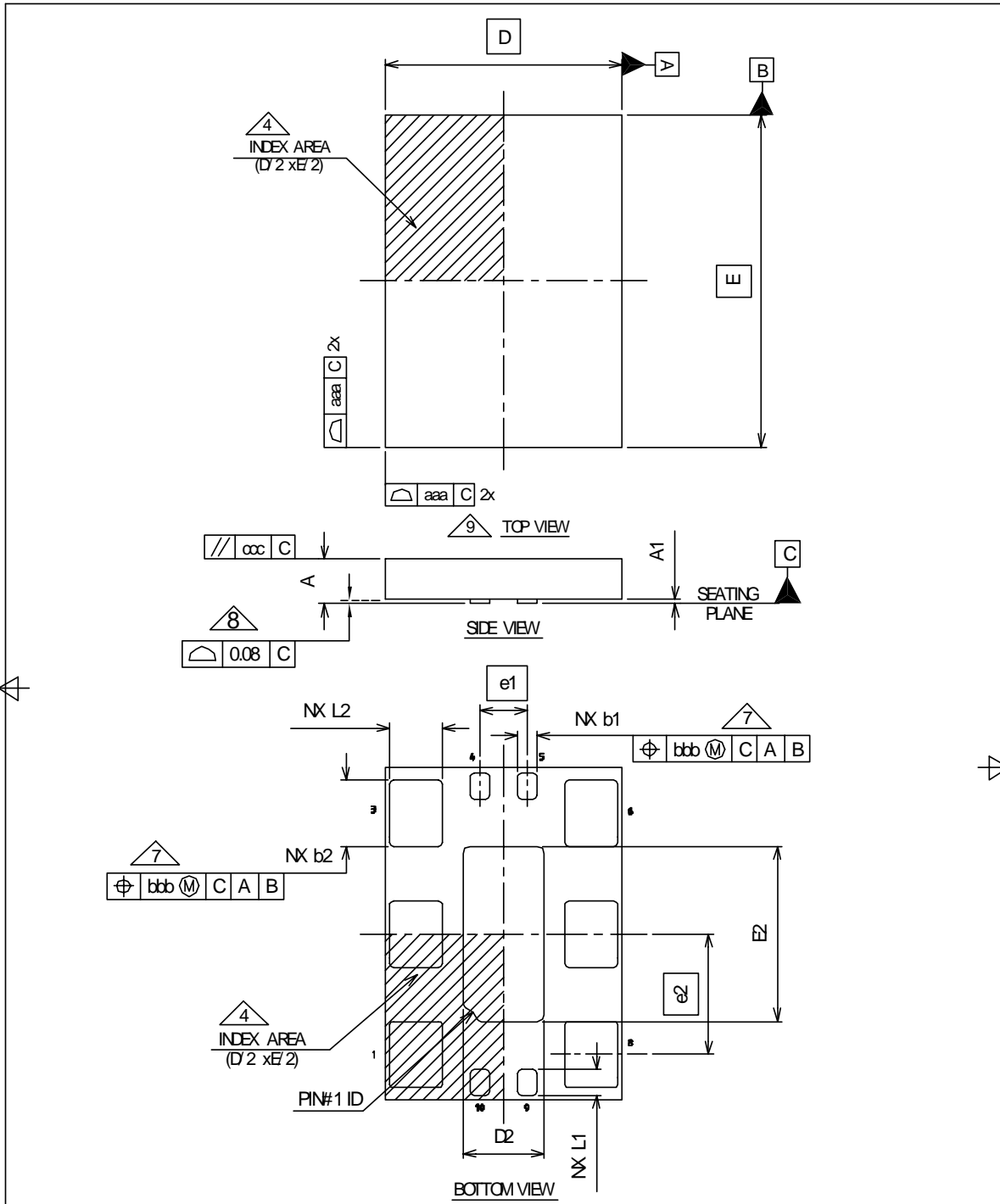

FOR REVISION UPDATE PLEASE REFER TO HISTORY OF CHANGES.

DRAFT 1	ORIGINATOR	ZHRJL		DWG NO : PKGM00305
	ENGINEERING MANAGER			MLP QJAD PACKAGE OUTLINE 5.00x7.00 MLPQ 10LD 1.00/ 2.54 PITCH
	TOOLING MANAGER	ARAVEN		
	TECH. SALES MANAGER	KANDA		
	DATE	2007-APR-18		
			Page 1 of 4	

Package Outline, continued
Package Outline - K Suffix for 10-Lead VFQFN

COMMON DIMENSION						
TOLERANCE OF FORM AND POSITION						
aaa	0.15					
bbb	0.10					
ccc	0.10					

COMMON DIMENSION			
SYMBOL	V : Very thin		
	MN	NOM	MAX
A	0.80	0.90	1.00
A1	0.00	0.02	0.05
NOTES	1, 2	1, 2	1, 2

Summary Table				
Lead Pitch (e1 & e2)	Lead Count	Body Size	Very Very Thin Variation	Pin #1 ID
1.00/ 2.54	10	5.00X7.00	VNJR-1	R0.30



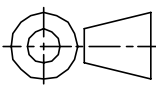

FOR REVISION UPDATE PLEASE REFER TO HISTORY OF CHANGES.

DRAFT 1	ORIGINATOR	ZAHRUL		DWG NO : PKGM00305
	ENGINEERING MANAGER			MLP QUAD PACKAGE OUTLINE 5.00x7.00 MLPQ 10LD 1.00/ 2.54 Pitch
	TOOLING MANAGER	ARAVEN		
	TECH SALES MANAGER	KANDA		
	DATE	2007-APR-18		
			PAGE 2 of 4	

Package Outline, continued

Package Outline - K Suffix for 10-Lead VFQFN

NOTE

1. Dimensioning and tolerancing conform to ASME Y14.5M 1994.
2. All dimensions are in millimeters, angles are in degrees(°).
3. N is the total number of terminals.
4.  The location of the terminal #1 identifier and terminal numbering convention conforms to JEDEC publication 95 SPP-002.
5. ND and NE refer to the number of terminals on each D and E side respectively.
6. NJR refers to NON JEDEC REGISTERED
7.  Dimension b applies to metallized terminal and is measured between 0.10mm and 0.30mm from the terminal tip. If the terminal has the optional radius on the other end of the terminal, the dimension b should not be measured in that radius area.
8.  Coplanarity applies to the terminals and all other bottom surface metallization.
9.  Drawing shown are for illustration only.

FOR REVISION UPDATE PLEASE REFER TO HISTORY OF CHANGES.

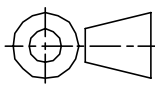
DRAFT 1	ORIGINATOR	ZAHRL		DWG NO: PKGM.00305
	ENGINEERING MANAGER			MLP QUAD PACKAGE OUTLINE
	TOOLING MANAGER	ARAVEN		5.00x7.00 MLPQ 10LD
	TECH. SALES MANAGER	KANDA		1.00/ 2.54 PITCH
	DATE	2007-APR-18		PAGE 3 of 4

Package Outline, continued

Package Outline - K Suffix for 10-Lead VFQFN

Variation Symbol	VNJR-1									Note
D BSC	5.00									
E BSC	7.00									
b1	MN	0.35								
	NOM	0.40								
	MAX	0.45								
b2	MN	1.35								
	NOM	1.40								
	MAX	1.45								
D2	MN	1.55								
	NOM	1.70								
	MAX	1.80								
E2	MN	3.55								
	NOM	3.70								
	MAX	3.80								
L1	MN	0.45								
	NOM	0.55								
	MAX	0.65								
L2	MN	1.00								
	NOM	1.10								
	MAX	1.20								
N	10									
ND	2									
NE	3									
NOTES	-									
PAD DESIGN	-									

FOR REVISION UPDATE PLEASE REFER TO HISTORY OF CHANGES.

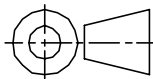
DRAFT 1	ORIGINATOR	ZAHRL		DWG NO : PKGM00305
	ENGINEERING MANAGER			MLP QUAD PACKAGE OUTLINE 5.00x7.00 MLPQ 10LD 1.00/2.54 Pitch
	TOOLING MANAGER	ARAVEN		
	TECH. SALES MANAGER	KANDA		
	DATE	2007-APR-18		
			PAGE 4 of 4	

Ordering Information

Table 10. Ordering Information

Part/Order Number	Marking	Package	Shipping Packaging	Temperature
83PN625DKILF	ICS3PN625DIL	"Lead-Free" 10 Lead VFQFN	Tray	-40°C to 85°C
83PN625DKILFT	ICS3PN625DIL	"Lead-Free" 10Lead VFQFN	2500 Tape & Reel	-40°C to 85°C

NOTE: Parts that are ordered with an "LF" suffix to the part number are the Pb-Free configuration and are RoHS compliant.

While the information presented herein has been checked for both accuracy and reliability, Integrated Device Technology (IDT) assumes no responsibility for either its use or for the infringement of any patents or other rights of third parties, which would result from its use. No other circuits, patents, or licenses are implied. This product is intended for use in normal commercial and industrial applications. Any other applications, such as those requiring high reliability or other extraordinary environmental requirements are not recommended without additional processing by IDT. IDT reserves the right to change any circuitry or specifications without notice. IDT does not authorize or warrant any IDT product for use in life support devices or critical medical instruments.

Revision History Sheet

Rev	Table	Page	Description of Change	Date
A		3, 15-18	Supply Voltage, V_{CC} . Rating changed from 4.5V min. to 3.63V per Errata NEN-11-03. Updated 10-Lead VFQFN package information.	6/02/11



www.IDT.com

6024 Silver Creek Valley Road
San Jose, California 95138

Sales

800-345-7015 (inside USA)
+408-284-8200 (outside USA)
Fax: 408-284-2775
www.IDT.com/go/contactIDT

Technical Support

netcom@idt.com
+480-763-2056

DISCLAIMER Integrated Device Technology, Inc. (IDT) and its subsidiaries reserve the right to modify the products and/or specifications described herein at any time and at IDT's sole discretion. All information in this document, including descriptions of product features and performance, is subject to change without notice. Performance specifications and the operating parameters of the described products are determined in the independent state and are not guaranteed to perform the same way when installed in customer products. The information contained herein is provided without representation or warranty of any kind, whether express or implied, including, but not limited to, the suitability of IDT's products for any particular purpose, an implied warranty of merchantability, or non-infringement of the intellectual property rights of others. This document is presented only as a guide and does not convey any license under intellectual property rights of IDT or any third parties.

IDT's products are not intended for use in life support systems or similar devices where the failure or malfunction of an IDT product can be reasonably expected to significantly affect the health or safety of users. Anyone using an IDT product in such a manner does so at their own risk, absent an express, written agreement by IDT.

Integrated Device Technology, IDT and the IDT logo are registered trademarks of IDT. Other trademarks and service marks used herein, including protected names, logos and designs, are the property of IDT or their respective third party owners.

Copyright 2011. All rights reserved.