

MULTIPLIER AND ZERO DELAY BUFFER

ICS570

Description

The ICS570 is a high-performance Zero Delay Buffer (ZDB) which integrates IDT's proprietary analog/digital Phase Locked Loop (PLL) techniques. The A version is recommended for 5 V designs and the B version for 3.3 V designs. The chip is part of IDT's ClockBlocks™ family, and was designed as a performance upgrade to meet today's higher speed and lower voltage requirements. The zero delay feature means that the rising edge of the input clock aligns with the rising edges of both output clocks, giving the appearance of no delay through the device. There are two outputs on the chip, one being a low-skew divide by two of the other output. The device incorporates an all-chip power down/tri-state mode that stops the internal PLL and puts both outputs into a high impedance state.

The ICS570 is ideal for synchronizing outputs in a large variety of systems, from personal computers to data communications to graphics/video. By allowing off-chip feedback paths, the device can eliminate the delay through other devices.

The ICS570 A and B versions were designed to improve input to output jitter from the original ICS570M version, and are recommended for all new designs.

Features

- 8-pin SOIC package
- Available in Pb (lead) free package
- Pin-for-pin replacement and upgrade to ICS570M
- Functional equivalent to AV9170 (not a pin-for-pin replacement)
- Low input to output skew of 300 ps max (>60 MHz outputs)
- Ability to choose between 14 different multipliers from 0.5x to 32x
- Output clock frequency up to 170 MHz at 3.3 V
- Can recover degraded input clock duty cycle
- Output clock duty cycle of 45/55
- Power Down and Tri-State Mode
- Passes spread spectrum clock modulation
- Full CMOS clock swings with 25 mA drive capability at TTL levels
- Advanced, low power CMOS process
- ICS570B has an operating voltage of 3.3 V (±5%)
- ICS570A has an operating voltage of 5.0 V (±5%)
- Industrial temperature version available

Block Diagram

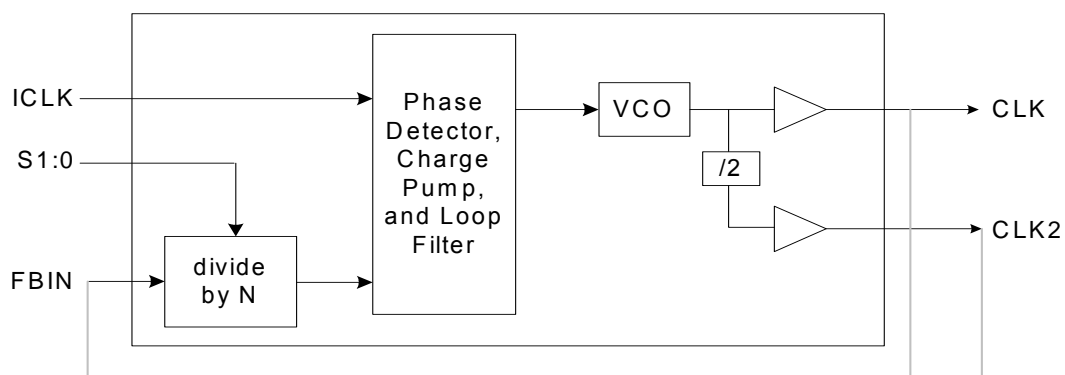

External feedback can come from CLK or CLK/2 (see table on page 2)

Pin Assignment

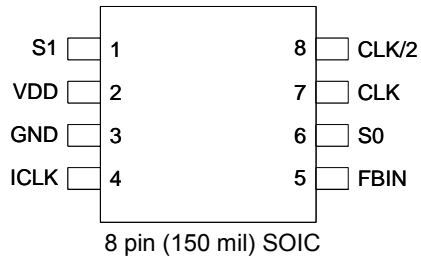

Clock Multiplier Decoding Table

(Multiplies Input clock by amount shown)

#1	#0	FBIN from CLK		FBIN from CLK/2		ICS570B (3.3 V)		ICS570A (5.0 V)	
		CLK	CLK/2	CLK	CLK/2	ICLK Input Range	FB from CLK/2*	ICLK Input Range	FB from CLK/2*
#1	#0	pin #7	pin #8	pin #7	pin #8				
0	0	Power Down and Tri-State				-		-	
0	M	x3	x1.5	x6	x3	3.75 to 28		2.5 to 25	
0	1	x4	x2	x8	x4	2.75 to 19		2.5 to 19	
M	0	x8	x4	x16	x8	2.5 to 9.5		2.5 to 9.5	
M	M	x6	x3	x12	x6	2.5 to 12.5		2.5 to 12.5	
M	1	x10	x5	x20	x10	2.5 to 7.5		2.5 to 7.5	
1	0	x1	/2	x2	x1	11 to 85		5 to 75	
1	M	x16	x8	x32	x16	1.5 to 5		1.5 to 5	
1	1	x2	x1	x4	x2	5.5 to 37.5		2.5 to 37.5	

0 = connect directly to ground

M = leave unconnected (self-biases to VDD/2)

1 = connect directly to VDD

*Input range with CLK feedback is double that for CLK/2

Pin Descriptions

Pin Number	Pin Name	Pin Type	Pin Description
1	S1	Input	Select 1 for output clock. Connect to GND, VDD, or float per decoding
2	VDD	Power	Connect to +3.3 V (ICS570B). Connect to +5.0 V (ICS570A).
3	GND	Power	Connect to ground.
4	ICLK	Input	Reference clock input.
5	FBIN	Input	Feedback clock input.
6	S0	Input	Select 0 for output clock. Connect to GND, VDD, or float per decoding
7	CLK	Output	Clock output per table above.
8	CLK/2	Output	Clock output per table above. Low skew divide by two of pin 7 clock.

External Components

The ICS570 requires a 0.01 μ F decoupling capacitor to be connected between VDD and GND. It must be connected close to the part to minimize lead inductance. No external power supply filtering is required for this device. A 33 Ω series terminating resistor can be used next to each output pin.

Recommended Circuit

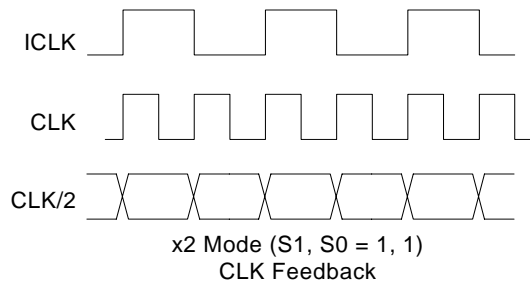
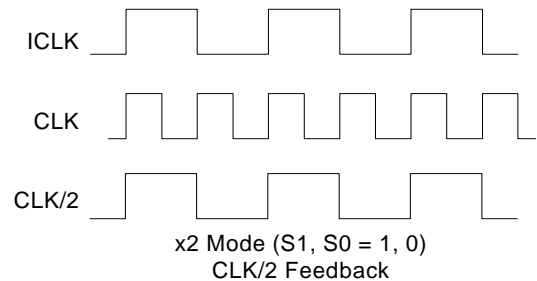
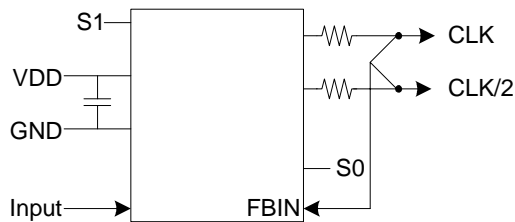

Using CLK as the feedback will always result in synchronized rising edges between ICLK and CLK. However, the CLK/2 could be a falling edge compared with ICLK. IDT recommends using CLK/2 feedback whenever possible. This will synchronize the rising edges of all three clocks.

Clock Period Jitter Tables (ICS570A)

All jitter values are considered typical measured at 25° C with 27 Ω termination resistor and 15 pF loads on both CLK and CLK/2. The feedback is from CLK/2 to FBIN. Note that if an output is unused, it should be left unconnected to improve output jitter on the active output clocks.

Absolute and One Sigma Jitter (ps)

S	S	CLKIN	CLK = 50M			CLK/2 = 25M		
			Multiplier	P to P	1 sigma	Multiplier	P to P	1 sigma
0	M	8.333	6x	± 115	80	3x	± 65	20
0	1	6.25	8x	± 115	80	4x	± 60	20
M	0	3.125	16x	± 120	80	8x	± 55	20
M	M	4.167	12x	± 120	90	6x	± 60	20
M	1	2.5	20x	± 120	80	10x	± 60	20
1	0	25	2x	± 120	70	1x	± 55	20
1	M	1.5625	32x	± 120	80	16x	± 50	20
1	1	12.5	4x	± 120	80	2x	± 55	20

Absolute and One Sigma Jitter (ps)

S	S	CLKIN	CLK = 100M			CLK/2 = 50M		
			Multiplier	P to P	1 sigma	Multiplier	P to P	1 sigma
0	M	16.667	6x	± 135	100	3x	± 55	20
0	1	12.5	8x	± 140	100	4x	± 50	20
M	0	6.25	16x	± 140	110	8x	± 55	20
M	M	8.333	12x	± 140	110	6x	± 55	20
M	1	5	20x	± 135	100	10x	± 50	20
1	0	50	2x	± 120	90	1x	± 50	20
1	M	3.125	32x	± 135	100	16x	± 55	20
1	1	25	4x	± 130	90	2x	± 65	20

Absolute and One Sigma Jitter (ps)

S	S	CLKIN	CLK = 150M			CLK/2 = 75M		
			Multiplier	P to P	1 sigma	Multiplier	P to P	1 sigma
0	M	25	6x	± 160	120	3x	± 55	20
0	1	18.375	8x	± 165	120	4x	± 55	20
M	0	9.375	16x	± 170	120	8x	± 50	20
M	M	12.5	12x	± 160	120	6x	± 55	20
M	1	7.5	20x	± 160	120	10x	± 55	20

1	0	75	2x	±155	110	1x	±55	20
1	M	4.6875	32x	±165	120	16x	±55	20
1	1	37.5	4x	±160	110	2x	±50	20

Clock Period Jitter Tables (ICS570B)

All jitter values are considered typical measured at 25° C with 27 Ω termination resistor and 15 pF loads on both CLK and CLK/2. The feedback is from CLK/2 to FBIN. Note that if an output is unused, it should be left unconnected to improve output jitter on the active output clocks.

Absolute and One Sigma Jitter (ps)

S	S	CLKIN	CLK = 50M			CLK/2 = 25M		
			Multiplier	P to P	1 sigma	Multiplier	P to P	1 sigma
0	M	8.333	6x	±110	80	3x	±55	20
0	1	6.25	8x	±125	90	4x	±50	20
M	0	3.125	16x	±130	90	8x	±55	20
M	M	4.167	12x	±120	90	6x	±55	20
M	1	2.5	20x	±115	90	10x	±55	20
1	0	25	2x	±130	50	1x	±55	20
1	M	1.5625	32x	±120	90	16x	±55	20
1	1	12.5	4x	±120	60	2x	±55	20

Absolute and One Sigma Jitter (ps)

S	S	CLKIN	CLK = 100M			CLK/2 = 50M		
			Multiplier	P to P	1 sigma	Multiplier	P to P	1 sigma
0	M	16.667	6x	±100	70	3x	±45	20
0	1	12.5	8x	±100	70	4x	±45	20
M	0	6.25	16x	±110	80	8x	±45	20
M	M	8.333	12x	±100	70	6x	±45	20
M	1	5	20x	±105	70	10x	±40	20
1	0	50	2x	±90	60	1x	±40	20
1	M	3.125	32x	±95	70	16x	±45	20
1	1	25	4x	±105	70	2x	±60	20

Absolute and One Sigma Jitter (ps)

S	S	CLKIN	CLK = 150M			CLK/2 = 75M		
			Multiplier	P to P	1 sigma	Multiplier	P to P	1 sigma
0	M	25	6x	±115	70	3x	±50	20
0	1	18.375	8x	±120	80	4x	±50	20
M	0	9.375	16x	±130	90	8x	±50	20
M	M	12.5	12x	±130	90	6x	±45	20

M	1	7.5	20x	±130	90	10x	±45	20
1	0	75	2x	±115	90	1x	±45	20
1	M	4.6875	32x	±130	90	16x	±50	20
1	1	37.5	4x	±110	70	2x	±60	20

Absolute Maximum Ratings

Stresses above the ratings listed below can cause permanent damage to the ICS570. These ratings, which are standard values for IDT commercially rated parts, are stress ratings only. Functional operation of the device at these or any other conditions above those indicated in the operational sections of the specifications is not implied. Exposure to absolute maximum rating conditions for extended periods can affect product reliability. Electrical parameters are guaranteed only over the recommended operating temperature range.

Item	Rating
Supply Voltage, VDD	7 V
All Inputs and Outputs	-0.5 V to VDD+0.5 V
Ambient Operating Temperature, Commercial version	0 to +70° C
Ambient Operating Temperature, Industrial version	-40 to +85° C
Storage Temperature	-65 to +150° C
Junction Temperature	125° C
Soldering Temperature	260° C

Recommended Operation Conditions

Parameter	Min.	Typ.	Max.	Units
Ambient Operating Temperature, Commercial version	0		70	° C
Ambient Operating Temperature, Industrial version	-40		+85	° C
Power Supply Voltage (measured in respect to GND)	+3.15	+3.3	+3.45	V

DC Electrical Characteristics

Unless stated otherwise, $V_{DD} = 3.3\text{ V} \pm 5\%$, Ambient Temperature -40 to $+85^{\circ}\text{C}$

Parameter	Symbol	Conditions	Min.	Typ.	Max.	Units
Operating Voltage	VDD	ICS570B, ICS570M	3.15		3.45	V
		ICS570A, ICS570M	4.75		5.25	
Operating Current	IDD	ICS570B, ICS570M VDD=3.3 V, 50M input, S1:0 = 11		16		mA
		ICS570A, ICS570M VDD=5.0 V, 50M input, S1:0 = 11		25		mA
Input High Voltage	V_{IH}	ICLK, FBIN	2			V
Input Low Voltage	V_{IL}	ICLK, FBIN			0.8	V
Input High Voltage	V_{IH}	S0, S1	VDD-0.5			V
Input Low Voltage (mid-level)	V_{IM}	S0, S1		VDD/2		V
Input Low Voltage	V_{IL}	S0, S1			0.5	V
Output High Voltage (CMOS High)	V_{OH}	$I_{OH} = -4\text{ mA}$	VDD-0.4			V
Output High Voltage	V_{OH}	$I_{OH} = -12\text{ mA}$	2.4			V
Output Low Voltage	V_{OL}	$I_{OL} = 12\text{ mA}$			0.4	V
Short Circuit Current	I_{OS}	Each output		± 100		mA
Input Capacitance	C_{IN}	S0, S1		5		pF

AC Electrical Characteristics

Unless stated otherwise, $V_{DD} = 3.3\text{ V} \pm 5\%$, Ambient Temperature -40 to $+85^{\circ}\text{C}$

Parameter	Symbol	Conditions	Min.	Typ.	Max.	Units
Input Frequency, ICLK		FBIN from CLK/2	See table on page 2			
Output Clock Frequency		CLK	10		170	MHz
Output to Output Skew		ICS570B, ICS570M		100	175	ps
Output to Output Skew		$V_{DD}=5\text{ V}$, ICS570A		100	200	ps
Input to Output Jitter		40 - 150 MHz		100-250		ps
		ICS570M		600		ps
Input Skew, ICS570B , ICS570M		ICLK to FBIN, CLK>30MHz, Note 1	-300		300	ps
		ICLK to FBIN, CLK<10MHz, Note 1	-600		600	ps
Input Skew, ICS570A		ICLK to FBIN CLK>30MHz, Note 1	-1		1	ns
		ICLK to FBIN, CLK<10MHz, Note 1	-1.5		1.5	ns
Output Clock Rise Time		0.8 to 2.0V, Note 2		0.75		ns
Output Clock Fall Time		2.0 to 0.8V, Note 2		0.75		ns
Output Clock Duty Cycle		at $V_{DD}/2$	45	49 - 51	55	%

Note 1: Assumes clocks with same rise time, measured from rising edges at $V_{DD}/2$

Note 2: Measured with 27Ω terminating resistor and 15 pF loads

Thermal Characteristics

Parameter	Symbol	Conditions	Min.	Typ.	Max.	Units
Thermal Resistance Junction to Ambient	θ_{JA}	Still air		150		$^{\circ}\text{C}/\text{W}$
	θ_{JA}	1 m/s air flow		140		$^{\circ}\text{C}/\text{W}$
	θ_{JA}	3 m/s air flow		120		$^{\circ}\text{C}/\text{W}$
Thermal Resistance Junction to Case	θ_{JC}			40		$^{\circ}\text{C}/\text{W}$

Package Outline and Package Dimensions (8-pin SOIC, 150 Mil. Body)

Package dimensions are kept current with JEDEC Publication No. 95

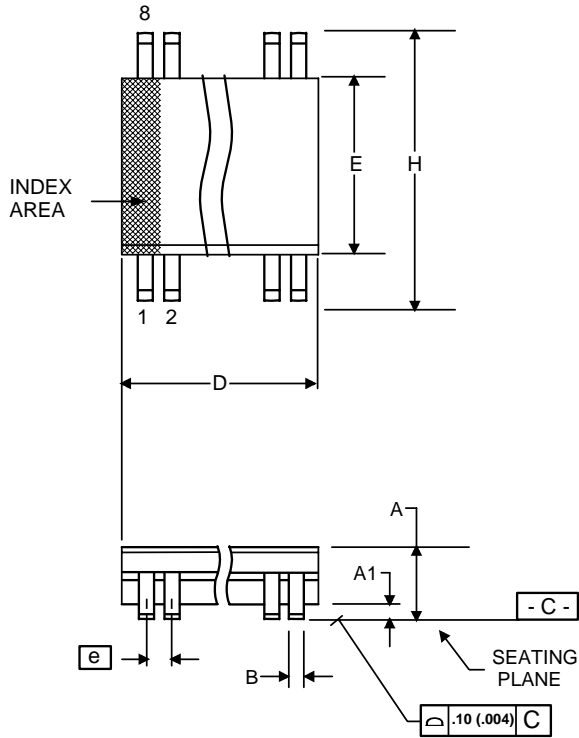

Symbol	Millimeters		Inches	
	Min	Max	Min	Max
A	1.35	1.75	.0532	.0688
A1	0.10	0.25	.0040	.0098
B	0.33	0.51	.013	.020
C	0.19	0.25	.0075	.0098
D	4.80	5.00	.1890	.1968
E	3.80	4.00	.1497	.1574
e	1.27 BASIC		0.050 BASIC	
H	5.80	6.20	.2284	.2440
h	0.25	0.50	.010	.020
L	0.40	1.27	.016	.050
a	0°	8°	0°	8°

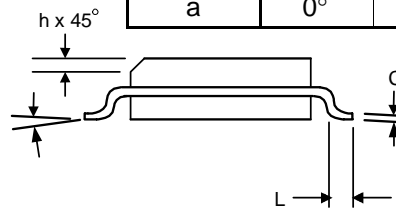

Ordering Information

Part / Order Number	Marking	Shipping Packaging	Package	Temperature
570A	ICS570A	Tubes	8-pin SOIC	0 to +70° C
570AT	ICS570A	Tape and Reel	8-pin SOIC	0 to +70° C
570AI	ICS570AI	Tubes	8-pin SOIC	-40 to 85° C
570AIT	ICS570AI	Tape and Reel	8-pin SOIC	-40 to 85° C
570AILF	570AILF	Tubes	8-pin SOIC	-40 to 85° C
570AILFT	570AILF	Tape and Reel	8-pin SOIC	-40 to 85° C
570ALF	570ALF	Tubes	8-pin SOIC	0 to +70° C
570ALFT	570ALF	Tape and Reel	8-pin SOIC	0 to +70° C
570B	ICS570B	Tubes	8-pin SOIC	0 to +70° C
570BT	ICS570B	Tape and Reel	8-pin SOIC	0 to +70° C
570BLF	ICS570BL	Tubes	8-pin SOIC	0 to +70° C
570BLFT	ICS570BL	Tape and Reel	8-pin SOIC	0 to +70° C
570BI	ICS570BI	Tubes	8-pin SOIC	-40 to 85° C
570BIT	ICS570BI	Tape and Reel	8-pin SOIC	-40 to 85° C
570BILF	570BILF	Tubes	8-pin SOIC	-40 to 85° C
570BILFT	570BILF	Tape and Reel	8-pin SOIC	-40 to 85° C
570M	ICS570M	Tubes	8-pin SOIC	0 to +70° C
570MT	ICS570M	Tape and Reel	8-pin SOIC	0 to +70° C
570MLF	570MLF	Tubes	8-pin SOIC	0 to +70° C
570MLFT	570MLF	Tape and Reel	8-pin SOIC	0 to +70° C
570MI	ICS570MI	Tubes	8-pin SOIC	-40 to 85° C
570MIT	ICS570MI	Tape and Reel	8-pin SOIC	-40 to 85° C

Parts that are ordered with a "LF" suffix to the part number are the Pb-Free configuration and are RoHS compliant.

While the information presented herein has been checked for both accuracy and reliability, Integrated Circuit Systems (IDT) assumes no responsibility for either its use or for the infringement of any patents or other rights of third parties, which would result from its use. No other circuits, patents, or licenses are implied. This product is intended for use in normal commercial applications. Any other applications such as those requiring extended temperature range, high reliability, or other extraordinary environmental requirements are not recommended without additional processing by IDT. IDT reserves the right to change any circuitry or specifications without notice. IDT does not authorize or warrant any IDT product for use in life support devices or critical medical instruments.

Innovate with IDT and accelerate your future networks. Contact:

www.IDT.com

For Sales

800-345-7015
408-284-8200
Fax: 408-284-2775

For Tech Support

408-284-4522
www.idt.com/go/clockhelp

Corporate Headquarters

Integrated Device Technology, Inc.
www.idt.com



www.IDT.com