

**LOCO™ PLL CLOCK MULTIPLIER**
**ICS512**
**Description**

The ICS512 is the most cost effective way to generate a high-quality, high frequency clock output and a reference clock from a lower frequency crystal or clock input. The name LOCO stands for Low Cost Oscillator, as it is designed to replace crystal oscillators in most electronic systems. Using Phase-Locked-Loop (PLL) techniques, the device uses a standard fundamental mode, inexpensive crystal to produce output clocks up to 200 MHz. With a reference output, this chip plus an inexpensive crystal can replace two oscillators

Stored in the chip's ROM is the ability to generate nine different multiplication factors, allowing one chip to output many common frequencies (see table on page 2).

This product is intended for clock generation. It has low output jitter (variation in the output period), but input to output skew and jitter are not defined or guaranteed. For applications which require defined input to output skew, use the ICS570B.

**Features**

- Packaged as 8-pin SOIC or die
- Pb (lead ) free package
- Upgrade of popular ICS502 with:
  - changed multiplier table
  - higher operating frequencies
- Zero ppm multiplication error
- Easy to cascade with other 5xx series
- Input crystal frequency of 5 - 27 MHz
- Input clock frequency of 2 - 50 MHz
- Output clock frequencies up to 200 MHz
- Compatible with all popular CPUs
- Duty cycle of 45/55 up to 200 MHz
- Mask option for nine selectable frequencies
- Operating voltages of 3.0 to 5.5 V
- Industrial temperature version available
- Advanced, low power CMOS process

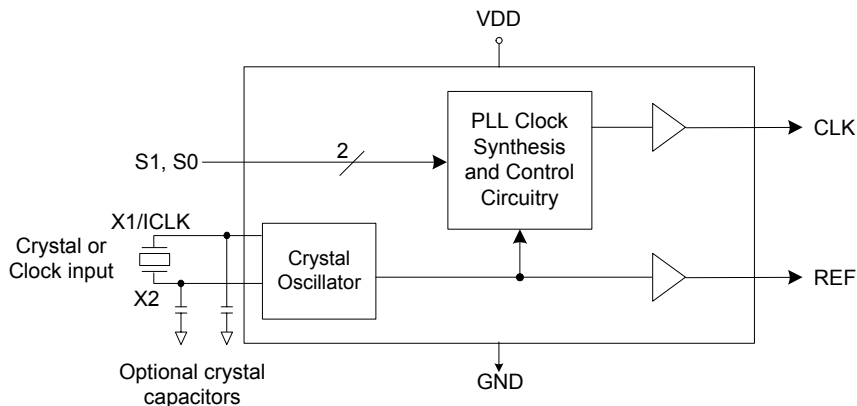
**Block Diagram**

## Pin Assignment

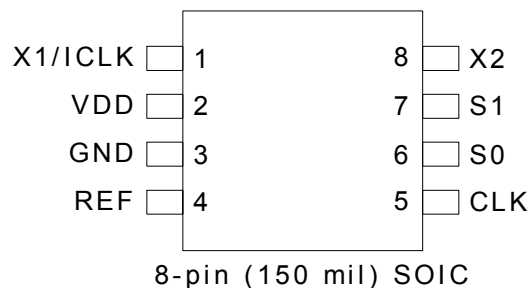

## Clock Output Table

S1	S0	CLK
0	0	4X input
0	M	5.333X input
0	1	5X input
M	0	2.5X input
M	M	2X input
M	1	3.333X input
1	0	6X input
1	M	3X input
1	1	8X input

0 = connect directly to ground

1 = connect directly to VDD

M = leave unconnected (floating)

## Common Output Frequencies Example (MHz)

<b>Output</b>	<b>20</b>	<b>24</b>	<b>30</b>	<b>32</b>	<b>33.33</b>	<b>37.5</b>	<b>40</b>	<b>48</b>	<b>50</b>	<b>60</b>	<b>64</b>
<b>Input</b>	10	12	10	16	16.66	15	10	12	20	10	16
<b>Selection (S1, S0)</b>	M,M	M,M	1, M	M,M	M,M	M,0	0,0	0,0	M,0	1,0	0,0
<b>Output</b>	<b>66.66</b>	<b>72</b>	<b>75</b>	<b>80</b>	<b>83.33</b>	<b>90</b>	<b>100</b>	<b>120</b>	<b>125</b>	<b>133.3</b>	<b>150</b>
<b>Input</b>	20	12	25	10	25	15	20	15	25	25	25
<b>Selection (S1, S0)</b>	M,1	1,0	1,M	1,1	M,1	1,0	0,1	1,1	0,1	0,M	1,0

Note that all of the above are achieved using a common, inexpensive 10 MHz to 25 MHz crystal. Consult IDT on how to achieve other output frequencies.

## Pin Descriptions

Pin Number	Pin Name	Pin Type	Pin Description
1	XI/ICLK	Input	Crystal connection or clock input.
2	VDD	Power	Connect to +3.3 V or +5 V.
3	GND	Power	Connect to ground.
4	NC	REF	Buffered crystal oscillator output clock.
5	CLK	Output	Clock output per table above.
6	S0	Tri-level Input	Multplier select pin 0. Connect to GND or VDD or float.
7	S1	Tri-level Input	Multplier select pin 1. Connect to GND or VDD or float.
8	X2	Output	Crystal connection. Leave unconnected for clock input.

## External Components

### Decoupling Capacitor

As with any high-performance mixed-signal IC, the ICS512 must be isolated from system power supply noise to perform optimally.

A decoupling capacitor of 0.01 $\mu$ F must be connected between VDD and GND. It must be connected close to the ICS512 to minimize lead inductance. No external power supply filtering is required for the ICS512.

### Series Termination Resistor

A 33 $\Omega$  terminating resistor can be used next to the CLK pin. The total on-chip capacitance is approximately 12 pF. A parallel resonant, fundamental mode crystal should be used.

## Crystal Load Capacitors

The device crystal connections should include pads for small capacitors from X1 to ground and from X2 to ground. These capacitors are used to adjust the stray capacitance of the board to match the nominally required crystal load capacitance. Because load capacitance can only be increased in this trimming process, it is important to keep stray capacitance to a minimum by using very short PCB traces (and no vias) between the crystal and device. Crystal capacitors, if needed, must be connected from each of the pins X1 and X2 to ground.

The value (in pF) of these crystal caps should equal  $(C_L - 12 \text{ pF}) \times 2$ . In this equation,  $C_L$  = crystal load capacitance in pF. Example: For a crystal with a 16 pF load capacitance, each crystal capacitor would be 8 pF  $[(16 - 12) \times 2] = 8$ .

## Absolute Maximum Ratings

Stresses above the ratings listed below can cause permanent damage to the ICS512. These ratings, which are standard values for IDT commercially rated parts, are stress ratings only. Functional operation of the device at these or any other conditions above those indicated in the operational sections of the specifications is not implied. Exposure to absolute maximum rating conditions for extended periods can affect product reliability. Electrical parameters are guaranteed only over the recommended operating temperature range.

Item	Rating
Supply Voltage, VDD	7 V
All Inputs and Outputs	-0.5 V to VDD+0.5 V
Ambient Operating Temperature (commercial)	0 to +70° C
Ambient Operating Temperature (industrial)	-40 to +85° C
Storage Temperature	-65 to +150° C
Soldering Temperature	260° C

## Recommended Operation Conditions

Parameter	Min.	Typ.	Max.	Units
Ambient Operating Temperature (commercial)	0		+70	° C
Ambient Operating Temperature (industrial)	-40		+85	° C
Power Supply Voltage (measured in respect to GND)	+3.0		+5.0	V

## DC Electrical Characteristics

VDD=3.3 V ±5% , Ambient temperature 0 to +70° C, unless stated otherwise

Parameter	Symbol	Conditions	Min.	Typ.	Max.	Units
Operating Voltage	VDD		3		5.5	V
Input High Voltage, ICLK only	V <sub>IH</sub>	ICLK (pin 1)	(VDD/2)+1	VDD/2		V
Input Low Voltage, ICLK only	V <sub>IL</sub>	ICLK (pin 1)		VDD/2	(VDD/2)-1	V
Input High Voltage	V <sub>IH</sub>	S0, S1	VDD-0.5			V
Input Low Voltage	V <sub>IL</sub>	S0, S1			0.5	V
Output High Voltage, CMOS high	V <sub>OH</sub>	I <sub>OH</sub> = -8 mA	VDD-0.4			V
Output High Voltage	V <sub>OH</sub>	I <sub>OH</sub> = -12 mA	2.4			V
Output Low Voltage	V <sub>OL</sub>	I <sub>OL</sub> = 12 mA			0.4	V
IDD Operating Supply Current, 20 MHz crystal		No load, 100 MHz		9		mA
Short Circuit Current		CLK output		±70		mA
Input Capacitance, S1, S0		Pins 6, 7		4		pF

## AC Electrical Characteristics

VDD=3.3 V ±5%, Ambient Temperature 0 to +70° C, unless stated otherwise

Parameter	Symbol	Conditions	Min.	Typ.	Max.	Units
Input Frequency, crystal input	F <sub>IN</sub>		5		27	MHz
Input Frequency, clock input	F <sub>IN</sub>		2		50	MHz
Output Frequency, VDD = 4.5 to 5.5 V	F <sub>OUT</sub>	0 to +70°C	14		200	MHz
		-40 to +85°C	14		160	MHz
Output Frequency, VDD = 3.0 to 3.6 V	F <sub>OUT</sub>	0 to +70°C	14		160	MHz
		-40 to +85°C	14		145	MHz
Output Clock Rise Time	t <sub>OR</sub>	0.8 to 2.0 V		1		ns
Output Clock Fall Time	t <sub>OF</sub>	2.0 to 8.0V		1		ns
Output Clock Duty Cycle	t <sub>OD</sub>	at VDD/2	45	49-51	55	%
Absolute Clock Period Jitter	t <sub>ja</sub>	Deviation from mean		±200		ps
One Sigma Clock Period Jitter	t <sub>js</sub>			80		ps

Note: The phase relationship between input and output clocks can change at power up. For a fixed phase relationship, see the ICS570 or the ICS527.

## Package Outline and Package Dimensions (8-pin SOIC, 150 Mil. Narrow Body)

Package dimensions are kept current with JEDEC Publication No. 95

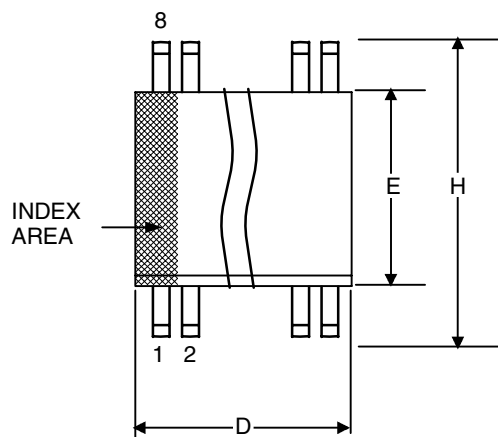

Symbol	Millimeters		Inches*	
	Min	Max	Min	Max
A	1.35	1.75	.0532	.0688
A1	0.10	0.25	.0040	.0098
B	0.33	0.51	.013	.020
C	0.19	0.25	.0075	.0098
D	4.80	5.00	.1890	.1968
E	3.80	4.00	.1497	.1574
e	1.27 BASIC		0.050 BASIC	
H	5.80	6.20	.2284	.2440
h	0.25	0.50	.010	.020
L	0.40	1.27	.016	.050
$\alpha$	0°	8°	0°	8°

\*For reference only. Controlling dimensions in mm.

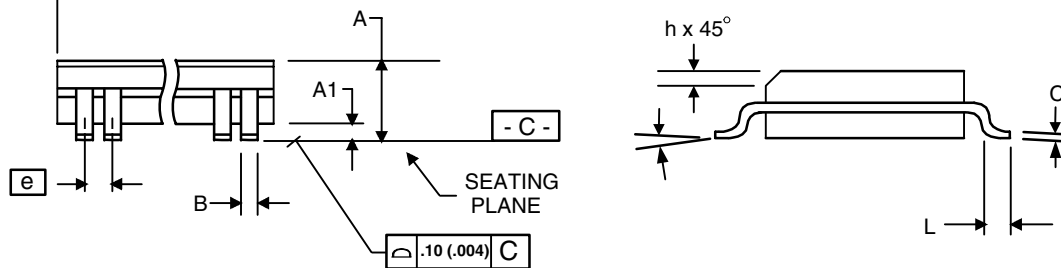

## Ordering Information

Part / Order Number	Marking	Shipping packaging	Package	Temperature
512MLF	512MLF	Tubes	8-pin SOIC	0 to +70° C
512MLFT	512MLF	Tape and Reel	8-pin SOIC	0 to +70° C
512MILF	512MILF	Tubes	8-pin SOIC	-40 to +85° C
512MILFT	512MILF	Tape and Reel	8-pin SOIC	-40 to +85° C

Parts that are ordered with a "LF" suffix to the part number are the Pb-Free configuration and are RoHS compliant.

While the information presented herein has been checked for both accuracy and reliability, Integrated Device Technology (IDT) assumes no responsibility for either its use or for the infringement of any patents or other rights of third parties, which would result from its use. No other circuits, patents, or licenses are implied. This product is intended for use in normal commercial applications. Any other applications such as those requiring extended temperature range, high reliability, or other extraordinary environmental requirements are not recommended without additional processing by IDT. IDT reserves the right to change any circuitry or specifications without notice. IDT does not authorize or warrant any IDT product for use in life support devices or critical medical instruments.

**Innovate with IDT and accelerate your future networks. Contact:**

**[www.IDT.com](http://www.IDT.com)**

**For Sales**

800-345-7015  
408-284-8200  
Fax: 408-284-2775

**For Tech Support**

[www.idt.com/go/clockhelp](http://www.idt.com/go/clockhelp)

---

**Corporate Headquarters**

Integrated Device Technology, Inc.  
[www.idt.com](http://www.idt.com)



[www.IDT.com](http://www.IDT.com)