



# FEMTOCLOCK™ CRYSTAL-TO-3.3V LVPECL CLOCK GENERATOR

# ICS843SDN

## General Description

The ICS843SDN is a Gigabit Ethernet Clock Generator. The ICS843SDN uses a 24MHz crystal to synthesize 120MHz. The ICS843SDN uses IDT's 3<sup>rd</sup> generation low phase noise VCO technology, and can achieve <1ps rms phase jitter performance over the 12kHz – 20MHz integration range. The ICS843SDN is packaged in a small 8-pin TSSOP, making it ideal for use in systems with limited board space.

## Features

- One differential 3.3V LVPECL output
- Crystal oscillator interface designed for 23.2MHz – 30MHz, 18pF parallel resonant crystal
- Output frequency range: 116MHz – 150MHz
- VCO range: 580MHz – 750MHz
- Output duty cycle range: 47% – 53%
- RMS phase jitter @ 120MHz, using a 24MHz crystal (12kHz – 20MHz): 0.81ps (typical)
- Full 3.3V supply mode
- 0°C to 70°C ambient operating temperature
- Industrial temperature information available upon request
- Available in lead-free (RoHS 6) package

**Table 1. Frequency Table - Typical Applications**

Crystal Frequency (MHz)	Output Frequency (MHz)
25	125
24	120

## Block Diagram

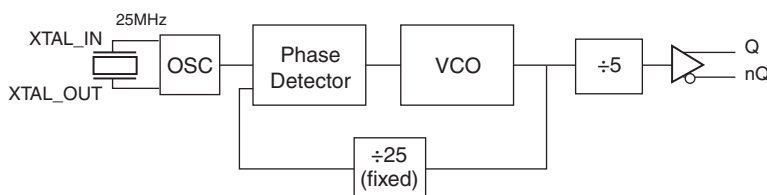

## Pin Assignment

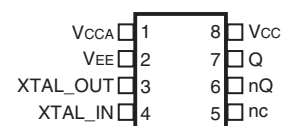

**ICS843SDN**  
**8 Lead TSSOP**  
**4.40mm x 3.0mm x 0.925mm package body**  
**G Package**  
**Top View**

**Table 2. Pin Descriptions**

Number	Name	Type	Description
1	V <sub>CCA</sub>	Power	Analog supply pin.
2	V <sub>EE</sub>	Power	Negative supply pin.
3, 4	XTAL_OUT XTAL_IN	Input	Crystal oscillator interface. XTAL_IN is the input, XTAL_OUT is the output.
5	nc	Unused	No connect.
6, 7	nQ, Q	Output	Differential output pair. LVPECL interface levels.
8	V <sub>CC</sub>	Power	Core supply pin.

## Absolute Maximum Ratings

NOTE: Stresses beyond those listed under *Absolute Maximum Ratings* may cause permanent damage to the device. These ratings are stress specifications only. Functional operation of product at these conditions or any conditions beyond those listed in the *DC Characteristics* or *AC Characteristics* is not implied. Exposure to absolute maximum rating conditions for extended periods may affect product reliability.

Item	Rating
Supply Voltage, V <sub>CC</sub>	4.6V
Inputs, V <sub>I</sub>	-0.5V to V <sub>CC</sub> + 0.5V
Outputs, I <sub>O</sub> Continuous Current Surge Current	50mA 100mA
Package Thermal Impedance, $\theta_{JA}$	129.5°C/W (0 mps)
Storage Temperature, T <sub>STG</sub>	-65°C to 150°C

## DC Electrical Characteristics

**Table 3A. Power Supply DC Characteristics, V<sub>CC</sub> = 3.3V ± 5%, V<sub>EE</sub> = 0V, T<sub>A</sub> = 0°C to 70°C**

Symbol	Parameter	Test Conditions	Minimum	Typical	Maximum	Units
V <sub>CC</sub>	Core Supply Voltage		3.135	3.3	3.465	V
V <sub>CCA</sub>	Analog Supply Voltage		V <sub>CC</sub> - 0.10	3.3	V <sub>CC</sub>	V
I <sub>EE</sub>	Power Supply Current				83	mA

**Table 3B. LVPECL DC Characteristics, V<sub>CC</sub> = 3.3V ± 5%, V<sub>EE</sub> = 0V, T<sub>A</sub> = 0°C to 70°C**

Symbol	Parameter	Test Conditions	Minimum	Typical	Maximum	Units
V <sub>OH</sub>	Output High Current; NOTE 1		V <sub>CC</sub> - 1.4		V <sub>CC</sub> - 0.9	V
V <sub>OL</sub>	Output Low Current; NOTE 1		V <sub>CC</sub> - 2.0		V <sub>CC</sub> - 1.7	V
V <sub>SWING</sub>	Peak-to-Peak Output Voltage Swing		0.6		1.0	V

NOTE 1: Outputs termination with 50Ω to V<sub>CC</sub> - 2V.

Table 4. Crystal Characteristics

Parameter	Test Conditions	Minimum	Typical	Maximum	Units
Mode of Oscillation		Fundamental			
Frequency; NOTE 1		23.2		30	MHz
Equivalent Series Resistance (ESR)				40	$\Omega$
Shunt Capacitance				7	pF

NOTE: It is not recommended to overdrive the crystal input with an external clock.

NOTE 1: Input frequency is limited to a range of 23.2MHz – 30MHz due to VCO range.

## AC Electrical Characteristics

Table 5. AC Characteristics,  $V_{CC} = 3.3V \pm 5\%$ ,  $V_{EE} = 0V$ ,  $T_A = 0^\circ C$  to  $70^\circ C$ 

Parameter	Symbol	Test Conditions	Minimum	Typical	Maximum	Units
$f_{OUT}$	Output Frequency		116		150	MHz
$f_{jit}(\emptyset)$	RMS Phase Jitter, Random; NOTE 1	120MHz, (Integration Range: 12kHz – 20MHz)		0.81		ps
$t_R / t_F$	Output Rise/Fall Time	20% to 80%	100		600	ps
odc	Output Duty Cycle		47		53	%

NOTE 1: Please refer to Phase Noise Plot.

## Typical Phase Noise at 120MHz

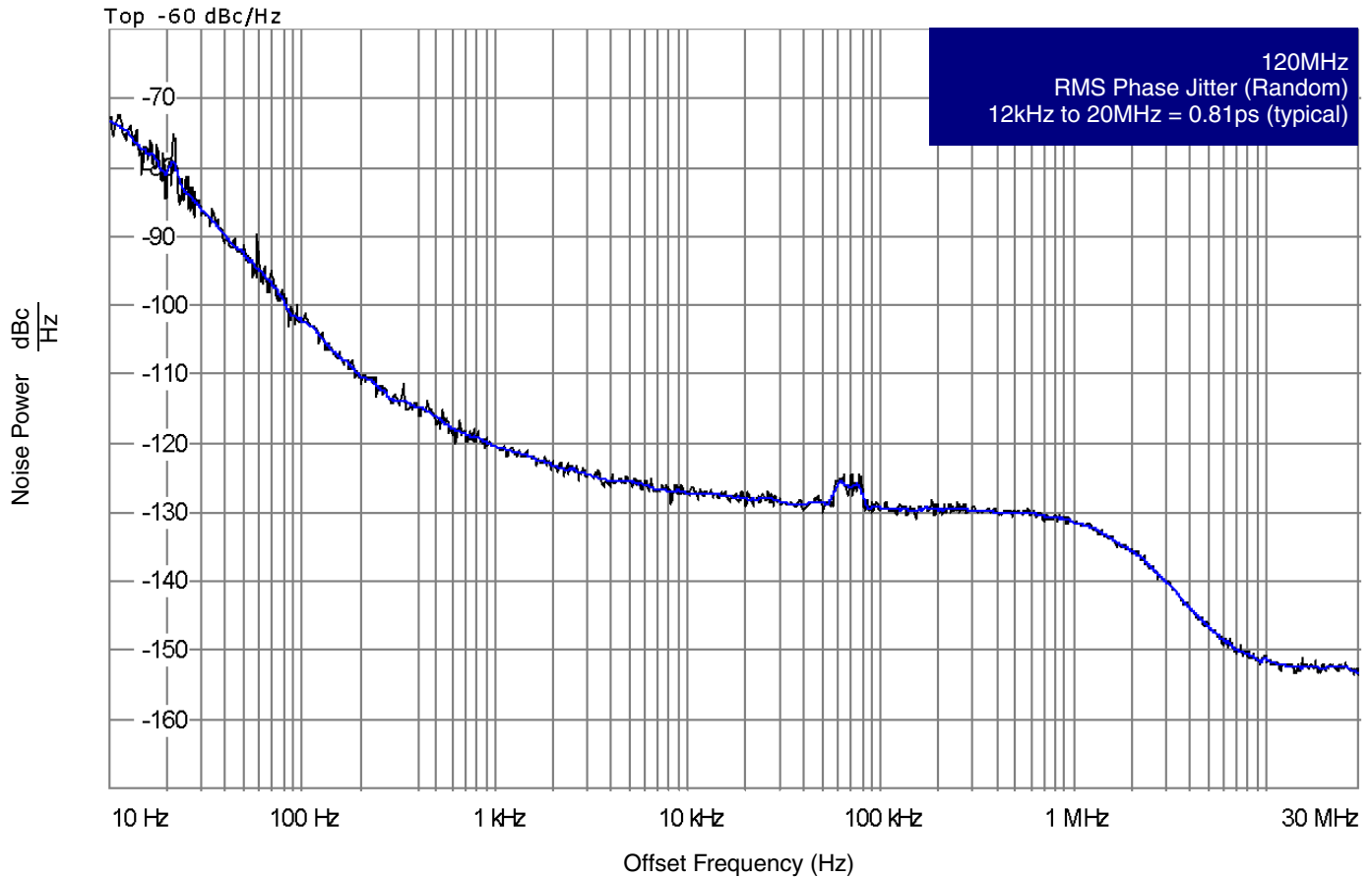

### Parameter Measurement Information

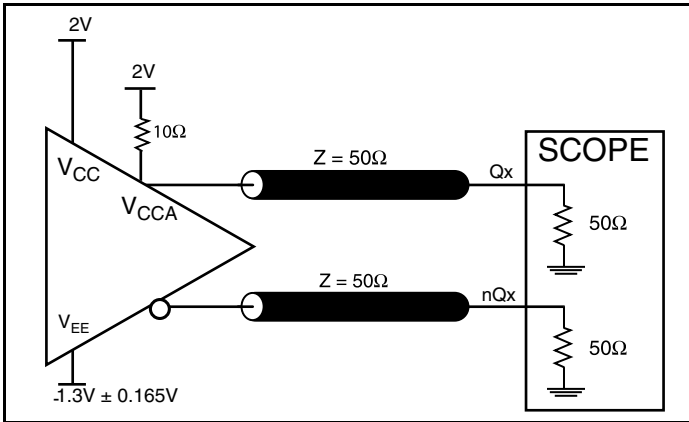

3.3V LVPECL Output Load AC Test Circuit

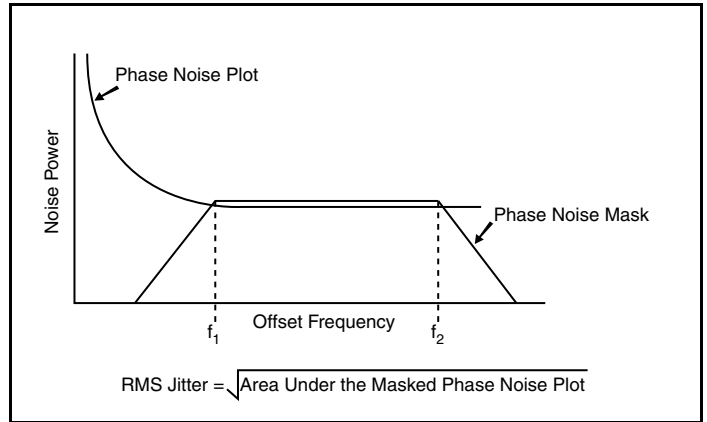

RMS Phase Jitter

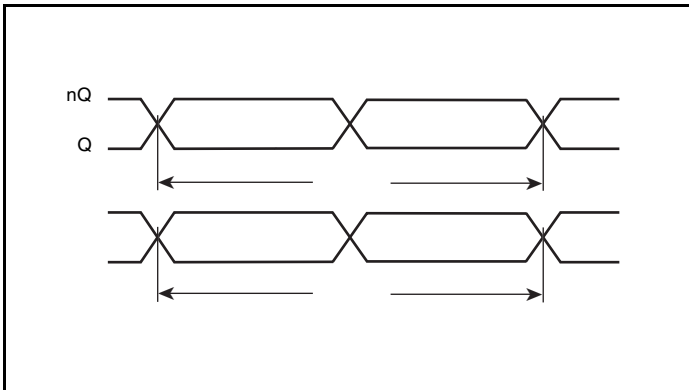

Output Duty Cycle/Pulse Width/Period

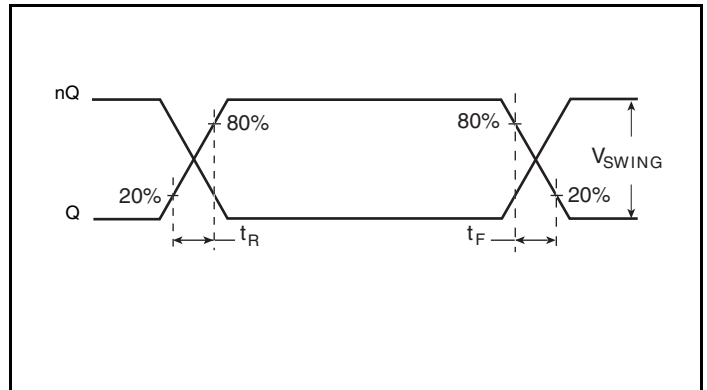

Output Rise/Fall Time

## Application Information

### Power Supply Filtering Technique

As in any high speed analog circuitry, the power supply pins are vulnerable to random noise. To achieve optimum jitter performance, power supply isolation is required. The ICS843SDN provides separate power supplies to isolate any high switching noise from the outputs to the internal PLL.  $V_{CC}$  and  $V_{CCA}$  should be individually connected to the power supply plane through vias, and  $0.01\mu\text{F}$  bypass capacitors should be used for each pin. *Figure 1* illustrates this for a generic  $V_{CC}$  pin and also shows that  $V_{CCA}$  requires that an additional  $10\Omega$  resistor along with a  $10\mu\text{F}$  bypass capacitor be connected to the  $V_{CCA}$  pin.

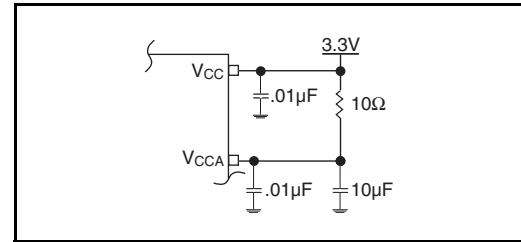

Figure 1. Power Supply Filtering

### Crystal Input Interface

The ICS843SDN has been characterized with  $18\text{pF}$  parallel resonant crystals. The capacitor values,  $C1$  and  $C2$ , shown in *Figure 2* below were determined using a  $25\text{MHz}$ ,  $18\text{pF}$  parallel resonant crystal and were chosen to minimize the ppm error. The optimum  $C1$  and  $C2$  values can be slightly adjusted for different board layouts.

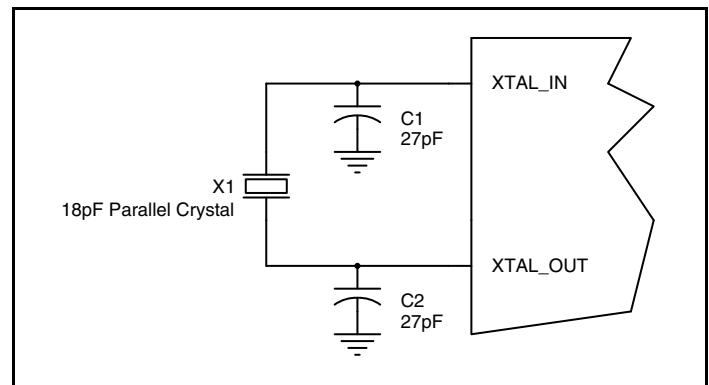

Figure 2. Crystal Input Interface

### Termination for 3.3V LVPECL Outputs

The clock layout topology shown below is a typical termination for LVPECL outputs. The two different layouts mentioned are recommended only as guidelines.

FOUT and nFOUT are low impedance follower outputs that generate ECL/LVPECL compatible outputs. Therefore, terminating resistors (DC current path to ground) or current sources must be used for functionality. These outputs are designed to drive  $50\Omega$  transmis-

sion lines. Matched impedance techniques should be used to maximize operating frequency and minimize signal distortion. *Figures 4A and 4B* show two different layouts which are recommended only as guidelines. Other suitable clock layouts may exist and it would be recommended that the board designers simulate to guarantee compatibility across all printed circuit and clock component process variations.

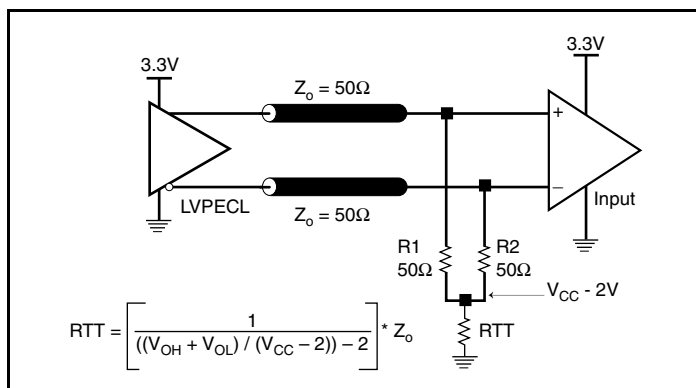

Figure 4A. 3.3V LVPECL Output Termination

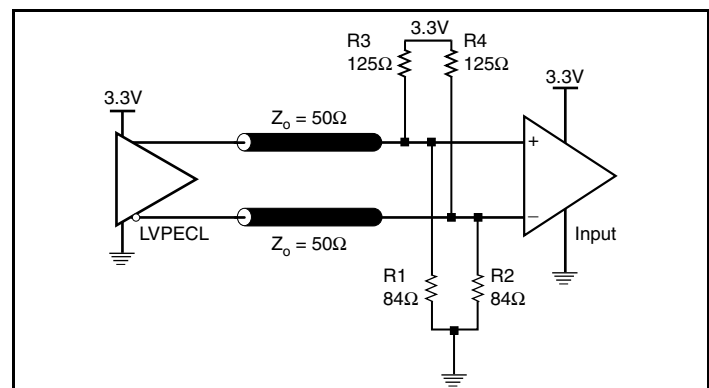

Figure 4B. 3.3V LVPECL Output Termination

## Schematic Example

Figure 5A shows an example of the ICS843SDN application schematic. In this example, the device is operated at  $V_{CC} = 3.3V$ . The 18pF parallel resonant crystal is used. The  $C1 = 27pF$  and  $C2 = 27pF$  are recommended for frequency accuracy. For a different board layout, the  $C1$  and  $C2$  values may be slightly adjusted for

optimizing frequency accuracy. Two examples of LVPECL terminations are shown in this schematic. Additional approaches are shown in the LVPECL Termination Application Note.

Note: Thermal pad (E-pad) must be connected to ground (VEE).

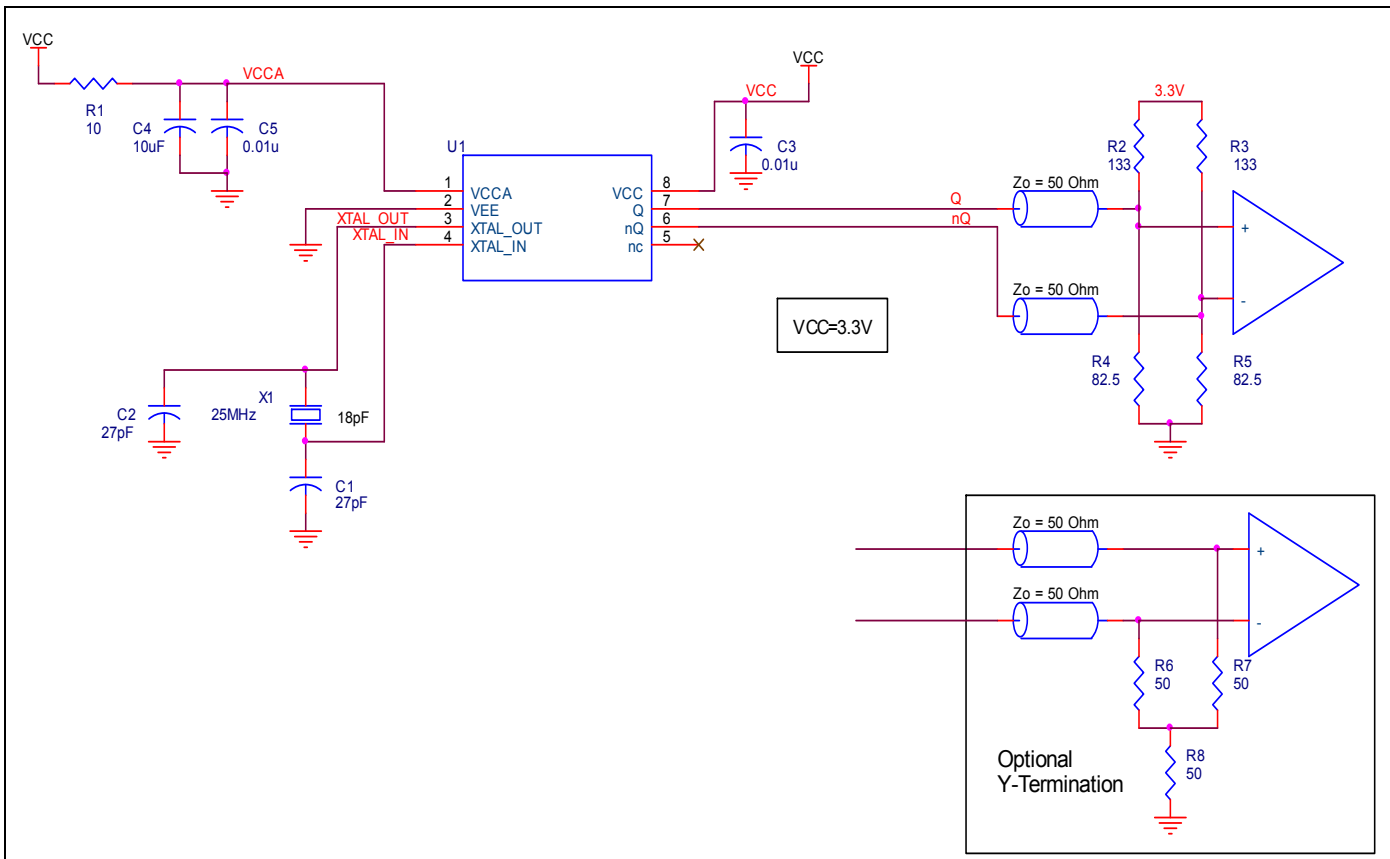

Figure 5A. ICS843SDN Schematic Example

## Schematic Example

Figure 5B shows an example of ICS843SDN P.C. board layout. The crystal X1 footprint shown in this example allows installation of either surface mount HC49S or through-hole HC49 package. The footprints of other components in this example are listed in the

Table 6 There should be at least one decoupling capacitor per power pin. The decoupling capacitors should be located as close as possible to the power pins. The layout assumes that the board has clean analog power ground plane.

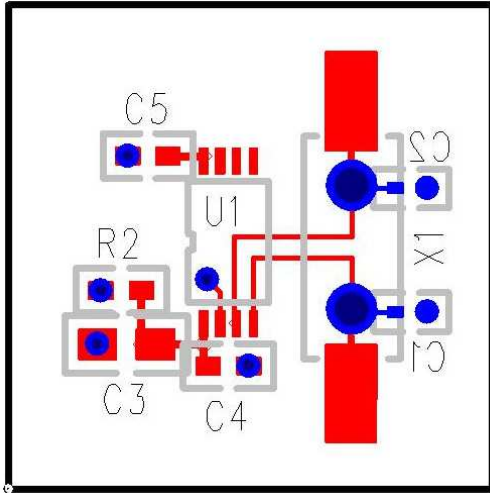

Figure 5B. ICS843SDN PC Board Layout Example

Table 6. Footprint Table

Reference	Size
C1, C2	0402
C3	0805
C4, C5	0603
R2	0603

NOTE: Table 6 lists component sizes shown in this layout example.

## Power Considerations

This section provides information on power dissipation and junction temperature for the ICS843SDN. Equations and example calculations are also provided.

### 1. Power Dissipation.

The total power dissipation for the ICS843SDN is the sum of the core power plus the power dissipated in the load(s). The following is the power dissipation for  $V_{CC} = 3.3V + 5\% = 3.465V$ , which gives worst case results.

NOTE: Please refer to Section 3 for details on calculating power dissipated in the load.

- Power (core)<sub>MAX</sub> =  $V_{CC\_MAX} * I_{EE\_MAX} = 3.465V * 83mA = \mathbf{287.60mW}$
- Power (outputs)<sub>MAX</sub> = **30mW/Loaded Output pair**

**Total Power**<sub>MAX</sub> (3.3V, with all outputs switching) =  $287.60mW + 30mW = \mathbf{317.60mW}$

### 2. Junction Temperature.

Junction temperature,  $T_j$ , is the temperature at the junction of the bond wire and bond pad and directly affects the reliability of the device. The maximum recommended junction temperature is 125°C.

The equation for  $T_j$  is as follows:  $T_j = \theta_{JA} * Pd\_total + T_A$

$T_j$  = Junction Temperature

$\theta_{JA}$  = Junction-to-Ambient Thermal Resistance

$Pd\_total$  = Total Device Power Dissipation (example calculation is in section 1 above)

$T_A$  = Ambient Temperature

In order to calculate junction temperature, the appropriate junction-to-ambient thermal resistance  $\theta_{JA}$  must be used. Assuming no air flow and a multi-layer board, the appropriate value is 129.5°C/W per Table 7 below.

Therefore,  $T_j$  for an ambient temperature of 70°C with all outputs switching is:

$70^\circ C + 0.318W * 129.5^\circ C/W = 111.2^\circ C$ . This is below the limit of 125°C.

This calculation is only an example.  $T_j$  will obviously vary depending on the number of loaded outputs, supply voltage, air flow and the type of board (multi-layer).

**Table 7. Thermal Resistance  $\theta_{JA}$  for 8 Lead TSSOP, Forced Convection**

Meters per Second	$\theta_{JA}$ by Velocity		
	0	1	2.5
Multi-Layer PCB, JEDEC Standard Test Boards	129.5°C/W	125.5°C/W	123.5°C/W

### 3. Calculations and Equations.

The purpose of this section is to derive the power dissipated into the load.

LVPECL output driver circuit and termination are shown in *Figure 6*.

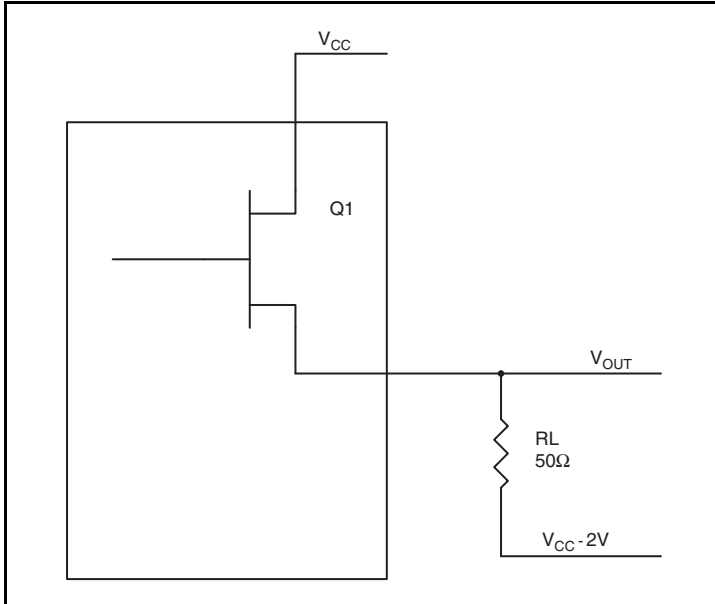

**Figure 6. LVPECL Driver Circuit and Termination**

To calculate worst case power dissipation into the load, use the following equations which assume a 50Ω load, and a termination voltage of  $V_{CC} - 2V$ .

- For logic high,  $V_{OUT} = V_{OH\_MAX} = V_{CC\_MAX} - 0.9V$   
 $(V_{CC\_MAX} - V_{OH\_MAX}) = 0.9V$
- For logic low,  $V_{OUT} = V_{OL\_MAX} = V_{CC\_MAX} - 1.7V$   
 $(V_{CC\_MAX} - V_{OL\_MAX}) = 1.7V$

$Pd\_H$  is power dissipation when the output drives high.

$Pd\_L$  is the power dissipation when the output drives low.

$$Pd\_H = [(V_{OH\_MAX} - (V_{CC\_MAX} - 2V))/R_L] * (V_{CC\_MAX} - V_{OH\_MAX}) = [(2V - (V_{CC\_MAX} - V_{OH\_MAX}))/R_L] * (V_{CC\_MAX} - V_{OH\_MAX}) = [(2V - 0.9V)/50\Omega] * 0.9V = \mathbf{19.8mW}$$

$$Pd\_L = [(V_{OL\_MAX} - (V_{CC\_MAX} - 2V))/R_L] * (V_{CC\_MAX} - V_{OL\_MAX}) = [(2V - (V_{CC\_MAX} - V_{OL\_MAX}))/R_L] * (V_{CC\_MAX} - V_{OL\_MAX}) = [(2V - 1.7V)/50\Omega] * 1.7V = \mathbf{10.2mW}$$

$$\text{Total Power Dissipation per output pair} = Pd\_H + Pd\_L = \mathbf{30mW}$$

## Reliability Information

Table 8.  $\theta_{JA}$  vs. Air Flow Table for a 8 Lead TSSOP

$\theta_{JA}$ vs. Air Flow			
Meters per Second	0	1	2.5
Multi-Layer PCB, JEDEC Standard Test Boards	129.5°C/W	125.5°C/W	123.5°C/W

## Transistor Count

The transistor count for ICS843SDN is: 2395

## Package Outline and Package Dimensions

Package Outline - G Suffix for 8 Lead TSSOP

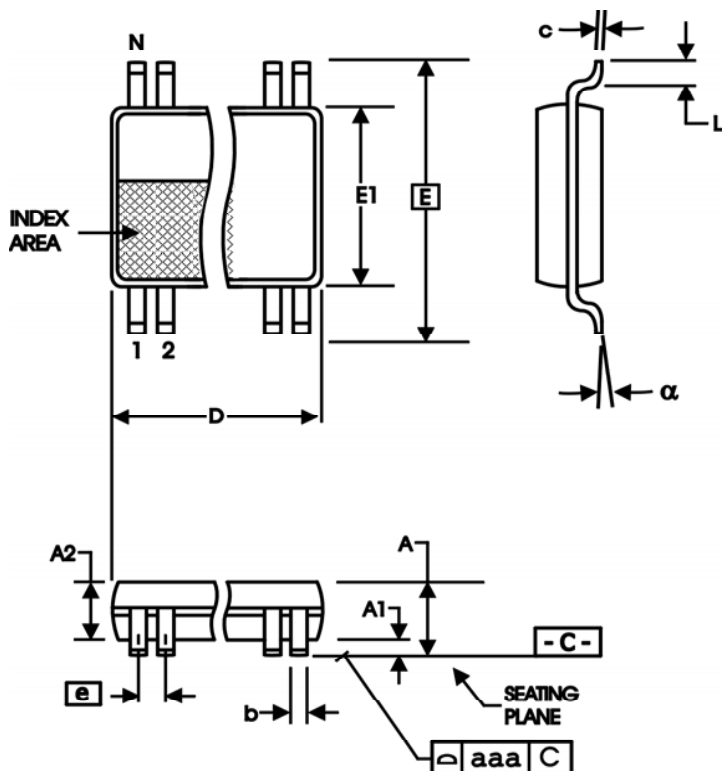

Table 9. Package Dimensions

All Dimensions in Millimeters		
Symbol	Minimum	Maximum
N	8	
A		1.20
A1	0.05	0.15
A2	0.80	1.05
b	0.19	0.30
c	0.09	0.20
D	2.90	3.10
E	6.40 Basic	
E1	4.30	4.50
e	0.65 Basic	
L	0.45	0.75
$\alpha$	0°	8°
aaa		0.10

Reference Document: JEDEC Publication 95, MO-153

## Ordering Information

Table 10. Ordering Information

Part/Order Number	Marking	Package	Shipping Packaging	Temperature
843SDNAGLF	SDNAL	“Lead-Free” 8 Lead TSSOP	Tube	0°C to 70°C
843SDNAGLFT	SDNAL	“Lead-Free” 8 Lead TSSOP	Tape & Reel	0°C to 70°C

## Revision History Sheet

Rev	Table	Page	Description of Change	Date
A	T4	1	Deleted HiPerClockS references throughout.	10/18/12
		3	Crystal Characteristics Table - added note.	
		6	Deleted application note, <i>LVC MOS to XTAL Interface</i> .	
	7	Added Note: Thermal pad (E-pad) must be connected to ground (VEE).		
	T10	12	Deleted quantity from tape and reel. Deleted lead-free note.	

ICS843SDN

FEMTOCLOCK™ CRYSTAL-TO-3.3V LVPECL CLOCK GENERATOR

## We've Got Your Timing Solution



6024 Silver Creek Valley Road  
San Jose, California 95138

### Sales

800-345-7015 (inside USA)  
+408-284-8200 (outside USA)  
Fax: 408-284-2775  
[www.IDT.com/go/contactIDT](http://www.IDT.com/go/contactIDT)

### Technical Support

[netcom@idt.com](mailto:netcom@idt.com)  
+480-763-2056

DISCLAIMER Integrated Device Technology, Inc. (IDT) and its subsidiaries reserve the right to modify the products and/or specifications described herein at any time and at IDT's sole discretion. All information in this document, including descriptions of product features and performance, is subject to change without notice. Performance specifications and the operating parameters of the described products are determined in the independent state and are not guaranteed to perform the same way when installed in customer products. The information contained herein is provided without representation or warranty of any kind, whether express or implied, including, but not limited to, the suitability of IDT's products for any particular purpose, an implied warranty of merchantability, or non-infringement of the intellectual property rights of others. This document is presented only as a guide and does not convey any license under intellectual property rights of IDT or any third parties.

IDT's products are not intended for use in applications involving extreme environmental conditions or in life support systems or similar devices where the failure or malfunction of an IDT product can be reasonably expected to significantly affect the health or safety of users. Anyone using an IDT product in such a manner does so at their own risk, absent an express, written agreement by IDT.

Integrated Device Technology, IDT and the IDT logo are registered trademarks of IDT. Other trademarks and service marks used herein, including protected names, logos and designs, are the property of IDT or their respective third party owners.

Copyright 2012. All rights reserved.