

DATE	REV	ECN	APP'D. BY
12-18-02	A0	-	RGC
03-10-04	A1	6351	RGC
5-28-04	A2	6286	TRM
1-19-06	A3	7441	JM

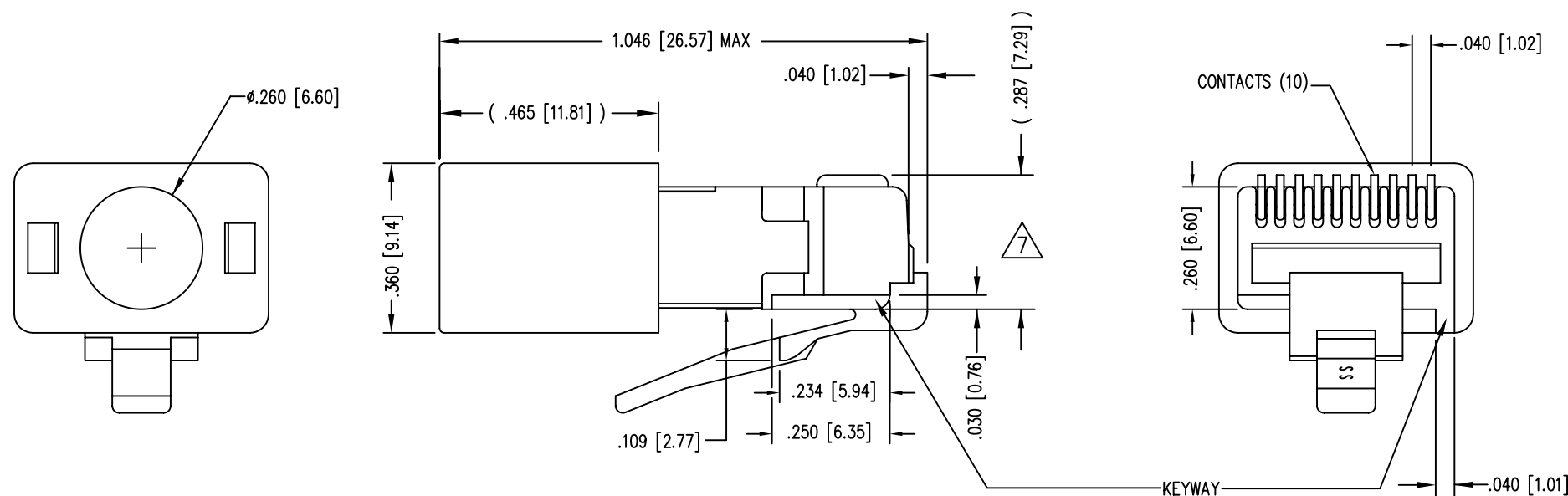
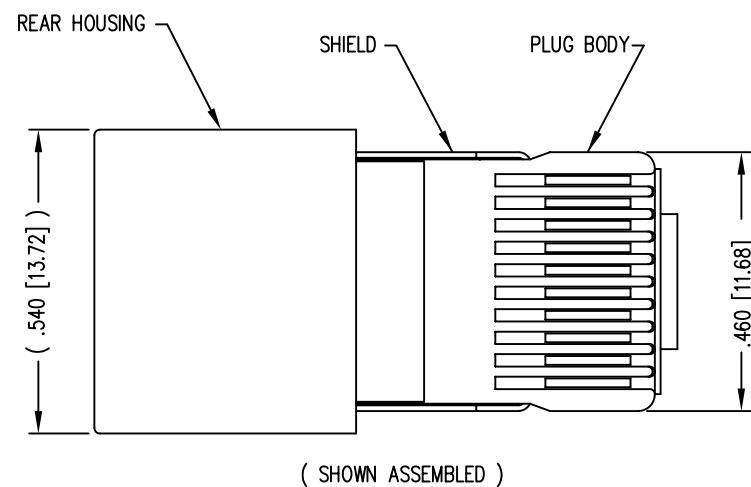

NOTES:

- 1- PLUG KIT CONSISTS OF :
PRE-INSERTED PLUG HOUSING & SHIELD
MANAGEMENT BAR
REAR HOUSING
FERRULE
- 2- MATERIALS :
FRONT HOUSING PLASTIC : CLEAR POLYCARBONATE, UL 94-V0
REAR HOUSING PLASTIC : BLACK POLYCARBONATE, UL 94-V0
SHIELD : TIN PLATED BRASS
CONTACTS : PHOSPHUR BRONZE, 50 MICRO INCHES SELECTIVE GOLD PLATING
- 3- CONTACTS TERMINATE SOLID OR STRANDED CONDUCTORS UP TO .037" DIAMETER ON .040" CENTERS
- 4- PLUG SPECIFICATIONS : MEETS CATEGORY 5 SPECS AS TESTED PER ANNEX B OF EIA/TIA 2840
- 5- TOLERANCES COMPLY WITH F.C.C. DIMENSION REQUIREMENTS.
- 6- DIMENSIONS NOT SHOWN COMPLY WITH F.C.C. REQUIREMENTS
- 7- TERMINATED PLUG HEIGHT: .237 [6.02] ±.005 [0.13]
- 8- FOR PRODUCT SPECIFICATIONS SEE PR026-01

BULK	50 MICRO-INCHES [1.27um]	937-SP-361010-RMK4R-A161
PACKAGE	CONTACT PLATING IN MATING AREA	PART NUMBER

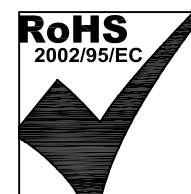
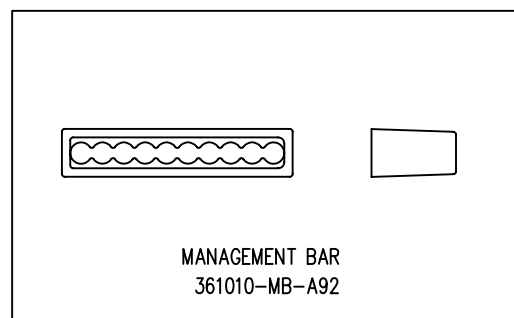
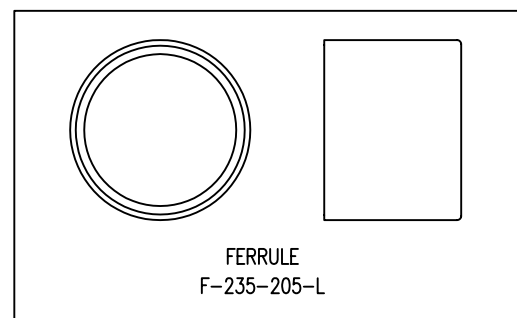

THIRD ANGLE PROJECTION

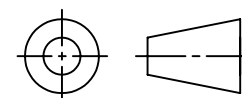

DO NOT SCALE DRAWING
DRAWING IS SUBJECT TO
CHANGE WITHOUT NOTICE

DIMENSIONS: INCHES [METRIC]

UNLESS OTHERWISE SPECIFIED
TOLERANCES ARE ±.005 [0.13]
ANGLES ARE ± 1°

SHEET NO. 1 OF 1

Bel Stewart Connector

11118 Susquehanna Trail South
Glen Rock, PA 17327-9199
(717) 235-7512 Fax: (717) 235-7954 <http://www.stewartconnector.com>

TITLE: 10 X 10 SHIELDED PLUG WITH MANAGEMENT BAR

THIS DRAWING AND THE SUBJECT MATTER SHOWN THEREON ARE CONFIDENTIAL AND THE PROPRIETARY PROPERTY OF BEL STEWART CONNECTOR AND SHALL NOT BE REPRODUCED, COPIED, OR USED IN ANY MANNER WITHOUT PRIOR WRITTEN CONSENT OF BEL STEWART CONNECTOR. THE SUBJECT MATTER MAY BE PATENTED OR A PATENT MAY BE PENDING.

DRN BY:	SAR	DATE	12-18-02
APPD BY:	RGC	DATE	12-18-02
DWG NO.	CT360171	REV.	A3