



EIGHT OUTPUT DIFFERENTIAL BUFFER FOR PCIE GEN1,2,3

9DB833

General Description

The 9DB833 zero-delay buffer supports PCIe Gen3 requirements, while being backwards compatible to PCIe Gen2 and Gen1. The 9DB833 is driven by a differential SRC output pair from an IDT 932S421 or 932SQ420 or equivalent main clock generator.

Recommended Application

8 output PCIe Gen1,2,3 zero-delay/fanout buffer

Output Features

- 8 - 0.7V current-mode differential HCSL output pairs
- Supports zero delay buffer mode and fanout mode
- Selectable bandwidth
- 50-110 MHz operation in PLL mode
- 5-166 MHz operation in Bypass mode

Features/Benefits

- 3 Selectable SMBus Addresses; multiple devices can share the same SMBus Segment
- OE# pins; suitable for Express Card applications
- PLL or bypass mode; PLL can de-jitter incoming clock
- Selectable PLL bandwidth; minimizes jitter peaking in downstream PLL's
- Spread Spectrum Compatible; tracks spreading input clock for low EMI
- SMBus Interface; unused outputs can be disabled
- Supports undriven differential outputs in Power Down mode for power management

Key Specifications

- Outputs cycle-cycle jitter <50ps
- Output to Output skew <50ps
- Phase jitter: PCIe Gen3 <1.0ps rms

Block Diagram

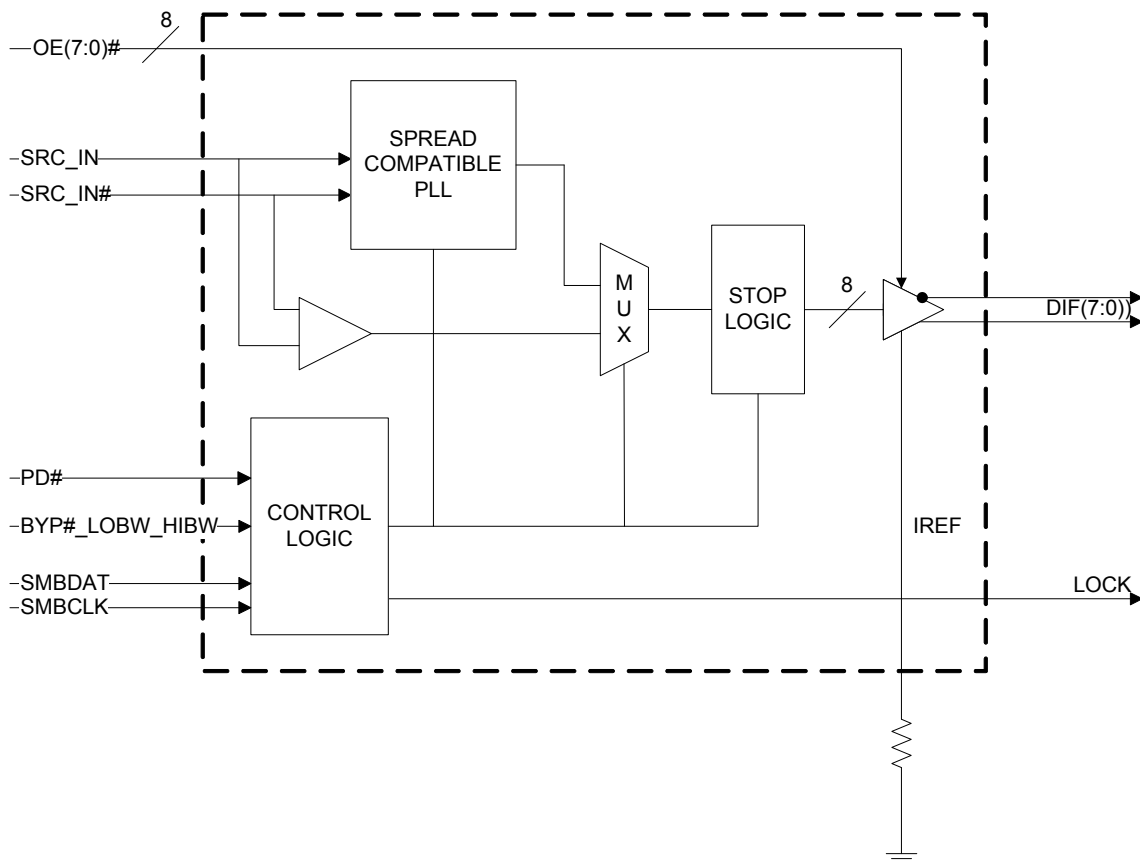

Pin Configuration

SRC_DIV#	1	9DB833	48	VDDA
VDDR	2		47	GND
GND	3		46	IREF
SRC_IN	4		45	LOCK
SRC_IN#	5		44	OE7#
OE0#	6		43	OE4#
OE3#	7		42	DIF_7
DIF_0	8		41	DIF_7#
DIF_0#	9		40	PD#
GND	10		39	VDD
VDD	11		38	DIF_6
DIF_1	12		37	DIF_6#
DIF_1#	13		36	OE6#
OE1#	14		35	OE5#
OE2#	15		34	DIF_5
DIF_2	16		33	DIF_5#
DIF_2#	17		32	GND
GND	18		31	VDD
VDD	19		30	DIF_4
DIF_3	20		29	DIF_4#
DIF_3#	21		28	SMB_ADR_tri
BYP#_HIBW_LOBW	22		27	VDD
SMBCLK	23		26	GND
SMBDAT	24		25	GND

Notes:

Highlighted Pins are the differences between 9DB803 and 9DB833.

Pin 22 and Pin 28 are latched on power up. Please make sure that the power supply to the pullup/pulldown resistors ramps at the same time as the main supply to the chip.

Operating Mode Readback Table

BYP#_LOBW_HIBW	MODE	Byte0, bit 3	Byte 0 bit 1
Low	Bypass	0	0
Mid	PLL 100M Hi BW	1	0
High	PLL 100M Low BW	0	1

Power Connections

Pin Number		Description
VDD	GND	
2	3	SRC_IN/SRC_IN#
11,19,31,39	10,18, 25,32	DIF(7:0)
27	26	DIGITAL VDD/GND
48	47	Analog VDD/GND for PLL in IREF

For best results, treat pin 2 as analog VDD.

SMBus Address Selection and Readback

SMB_ADR_tri	Address
Low	DA/DB
Mid	DC/DD
High	D8/D9

Tri-level Input Logic Levels

State of Pin	Voltage
Low	<0.8V
Mid	1.2<Vin<1.8V
High	Vin > 2.0V

Pin Descriptions

PIN #	PIN NAME	PIN TYPE	DESCRIPTION
1	SRC_DIV#	IN	Active low Input for determining SRC output frequency SRC or SRC/2. 0 = SRC/2, 1 = SRC
2	VDDR	PWR	3.3V power for differential input clock (receiver). This VDD should be treated as an analog power rail and filtered appropriately.
3	GND	PWR	Ground pin.
4	SRC_IN	IN	0.7 V Differential SRC TRUE input
5	SRC_IN#	IN	0.7 V Differential SRC COMPLEMENTARY input
6	OE0#	IN	Active low input for enabling DIF pair 0. 1 = disable outputs, 0 = enable outputs
7	OE3#	IN	Active low input for enabling DIF pair 3. 1 = disable outputs, 0 = enable outputs
8	DIF_0	OUT	0.7V differential true clock output
9	DIF_0#	OUT	0.7V differential Complementary clock output
10	GND	PWR	Ground pin.
11	VDD	PWR	Power supply, nominal 3.3V
12	DIF_1	OUT	0.7V differential true clock output
13	DIF_1#	OUT	0.7V differential Complementary clock output
14	OE1#	IN	Active low input for enabling DIF pair 1. 1 = disable outputs, 0 = enable outputs
15	OE2#	IN	Active low input for enabling DIF pair 2. 1 = disable outputs, 0 = enable outputs
16	DIF_2	OUT	0.7V differential true clock output
17	DIF_2#	OUT	0.7V differential Complementary clock output
18	GND	PWR	Ground pin.
19	VDD	PWR	Power supply, nominal 3.3V
20	DIF_3	OUT	0.7V differential true clock output
21	DIF_3#	OUT	0.7V differential Complementary clock output
22	BYP#_HIBW_LOBW	IN	Tri-level input to select bypass mode, Hi BW PLL, or Lo BW PLL mode
23	SMBCLK	IN	Clock pin of SMBUS circuitry, 5V tolerant
24	SMBDAT	I/O	Data pin of SMBUS circuitry, 5V tolerant

Pin Descriptions (cont.)

PIN #	PIN NAME	PIN TYPE	DESCRIPTION
25	GND	PWR	Ground pin.
26	GND	PWR	Ground pin.
27	VDD	PWR	Power supply, nominal 3.3V
28	SMB_ADR_tri	IN	SMBus address select bit. This is a tri-level input that decodes 1 of 3 SMBus Addresses.
29	DIF_4#	OUT	0.7V differential Complementary clock output
30	DIF_4	OUT	0.7V differential true clock output
31	VDD	PWR	Power supply, nominal 3.3V
32	GND	PWR	Ground pin.
33	DIF_5#	OUT	0.7V differential Complementary clock output
34	DIF_5	OUT	0.7V differential true clock output
35	OE5#	IN	Active low input for enabling DIF pair 5. 1 =disable outputs, 0 = enable outputs
36	OE6#	IN	Active low input for enabling DIF pair 6. 1 =disable outputs, 0 = enable outputs
37	DIF_6#	OUT	0.7V differential Complementary clock output
38	DIF_6	OUT	0.7V differential true clock output
39	VDD	PWR	Power supply, nominal 3.3V
40	PD#	IN	Asynchronous active low input pin used to power down the device. The internal clocks are disabled and the VCO and the crystal osc. (if any) are stopped.
41	DIF_7#	OUT	0.7V differential Complementary clock output
42	DIF_7	OUT	0.7V differential true clock output
43	OE4#	IN	Active low input for enabling DIF pair 4 1 =disable outputs, 0 = enable outputs
44	OE7#	IN	Active low input for enabling DIF pair 7. 1 =disable outputs, 0 = enable outputs
45	LOCK	OUT	3.3V output indicating PLL Lock Status. This pin goes high when lock is achieved.
46	IREF	OUT	This pin establishes the reference for the differential current-mode output pairs. It requires a fixed precision resistor to ground. 475ohm is the standard value for 100ohm differential impedance. Other impedances require different values. See data sheet.
47	GND_A	PWR	Ground pin for the PLL core.
48	VDD_A	PWR	3.3V power for the PLL core.

Absolute Maximum Ratings

Stresses above the ratings listed below can cause permanent damage to the 9DB833. These ratings, which are standard values for IDT commercially rated parts, are stress ratings only. Functional operation of the device at these or any other conditions above those indicated in the operational sections of the specifications is not implied. Exposure to absolute maximum rating conditions for extended periods can affect product reliability. Electrical parameters are guaranteed only over the recommended operating temperature range.

PARAMETER	SYMBOL	CONDITIONS	MIN	TYP	MAX	UNITS	NOTES
3.3V Core Supply Voltage	VDDA/R				4.6	V	1,2
3.3V Logic Supply Voltage	VDD				4.6	V	1,2
Input Low Voltage	V _{IL}		GND-0.5			V	1
Input High Voltage	V _{IH}	Except for SMBus interface			V _{DD} +0.5V	V	1
Input High Voltage	V _{IHSMB}	SMBus clock and data pins			5.5V	V	1
Storage Temperature	T _s		-65		150	°C	1
Junction Temperature	T _j				125	°C	1
Input ESD protection	ESD prot	Human Body Model	2000			V	1

¹Guaranteed by design and characterization, not 100% tested in production.

²Operation under these conditions is neither implied nor guaranteed.

Electrical Characteristics–Clock Input Parameters

TA = T_{COM} or T_{IND}; Supply Voltage VDD = 3.3 V +/-5%

PARAMETER	SYMBOL	CONDITIONS	MIN	TYP	MAX	UNITS	NOTES
Input High Voltage - DIF_IN	V _{IHDIF}	Differential inputs (single-ended measurement)	600	800	1150	mV	1
Input Low Voltage - DIF_IN	V _{ILDIF}	Differential inputs (single-ended measurement)	V _{SS} - 300	0	300	mV	1
Input Common Mode Voltage - DIF_IN	V _{COM}	Common Mode Input Voltage	300		1000	mV	1
Input Amplitude - DIF_IN	V _{SWING}	Peak to Peak value	300		1450	mV	1
Input Slew Rate - DIF_IN	dv/dt	Measured differentially	1		8	V/ns	1,2
Input Leakage Current	I _{IN}	V _{IN} = V _{DD} , V _{IN} = GND	-5		5	uA	1
Input Duty Cycle	d _{in}	Measurement from differential waveform	45		55	%	1
Input Jitter - Cycle to Cycle	J _{DIFin}	Differential Measurement	0		125	ps	1

¹Guaranteed by design and characterization, not 100% tested in production.

²Slew rate measured through +/-75mV window centered around differential zero

Electrical Characteristics–Current Consumption

TA = T_{COM} or T_{IND}; Supply Voltage VDD = 3.3 V +/-5%

PARAMETER	SYMBOL	CONDITIONS	MIN	TYP	MAX	UNITS	NOTES
Operating Supply Current	I _{DD3.3OP}	All outputs active @ 100MHz, C _L = Full load;		170	200	mA	1
Powerdown Current	I _{DD3.3PD}	All diff pairs driven		53	60	mA	1
	I _{DD3.3PDZ}	All differential pairs tri-stated		3	6	mA	1

¹Guaranteed by design and characterization, not 100% tested in production.

Electrical Characteristics–Input/Supply/Common Parameters

TA = T_{COM} or T_{IND}; Supply Voltage VDD = 3.3 V +/-5%

PARAMETER	SYMBOL	CONDITIONS	MIN	TYP	MAX	UNITS	NOTES
Ambient Operating Temperature	T _{COM}	Commercial range	0		70	°C	1
	T _{IND}	Industrial range	-40		85	°C	1
Input High Voltage	V _{IH}	Single-ended inputs, except SMBus, low threshold and tri-level inputs	2		V _{DD} + 0.3	V	1
Input Low Voltage	V _{IL}	Single-ended inputs, except SMBus, low threshold and tri-level inputs	GND - 0.3		0.8	V	1
Input Current	I _{IN}	Single-ended inputs, V _{IN} = GND, V _{IN} = VDD	-5	-0.02	5	uA	1
	I _{INP}	Single-ended inputs V _{IN} = 0 V; Inputs with internal pull-up resistors V _{IN} = VDD; Inputs with internal pull-down resistors	-200		200	uA	1
Input Frequency	F _{ibyp}	V _{DD} = 3.3 V, Bypass mode	5		166	MHz	2
	F _{ipll}	V _{DD} = 3.3 V, 100MHz PLL mode	50	100	110	MHz	2
Pin Inductance	L _{pin}				7	nH	1
Capacitance	C _{IN}	Logic Inputs, except DIF_IN	1.5		5	pF	1
	C _{INDIF_IN}	DIF_IN differential clock inputs	1.5		2.7	pF	1,4
	C _{OUT}	Output pin capacitance			6	pF	1
Clk Stabilization	T _{STAB}	From V _{DD} Power-Up and after input clock stabilization or de-assertion of PD# to 1st clock			1	ms	1,2
Input SS Modulation Frequency	f _{MODIN}	Allowable Frequency (Triangular Modulation)	30	31.5	33	kHz	1
OE# Latency	t _{LATOE#}	DIF start after OE# assertion DIF stop after OE# deassertion	1	2	3	cycles	1,3
Tdrive_PD#	t _{DRVPD}	DIF output enable after PD# de-assertion		13	300	us	1,3
Tfall	t _F	Fall time of control inputs			5	ns	1,2
Trise	t _R	Rise time of control inputs			5	ns	1,2
SMBus Input Low Voltage	V _{ILSMB}				0.8	V	1
SMBus Input High Voltage	V _{IHSMB}		2.1		V _{DDSMB}	V	1
SMBus Output Low Voltage	V _{OLSMB}	@ I _{PULLUP}			0.4	V	1
SMBus Sink Current	I _{PULLUP}	@ V _{OL}	4			mA	1
Nominal Bus Voltage	V _{DDSMB}	3V to 5V +/- 10%	2.7		5.5	V	1
SCLK/SDATA Rise Time	t _{RSMB}	(Max VIL - 0.15) to (Min VIH + 0.15)			1000	ns	1
SCLK/SDATA Fall Time	t _{FSMB}	(Min VIH + 0.15) to (Max VIL - 0.15)			300	ns	1
SMBus Operating Frequency	f _{MAXSMB}	Maximum SMBus operating frequency			100	kHz	1,5

¹Guaranteed by design and characterization, not 100% tested in production.

²Control input must be monotonic from 20% to 80% of input swing.

³Time from deassertion until outputs are >200 mV

⁴DIF_IN input

⁵The differential input clock must be running for the SMBus to be active

Electrical Characteristics–DIF 0.7V Current Mode Differential Outputs

$T_A = T_{COM}$ or T_{IND} ; Supply Voltage $V_{DD} = 3.3\text{ V} \pm 5\%$

PARAMETER	SYMBOL	CONDITIONS	MIN	TYP	MAX	UNITS	NOTES
Slew rate	T_{rf}	Scope averaging on	1	2	4	V/ns	1, 2, 3
Slew rate matching	ΔT_{rf}	Slew rate matching, Scope averaging on			20	%	1, 2, 4
Voltage High	V_{High}	Statistical measurement on single-ended signal using oscilloscope math function. (Scope averaging on)	660	800	850	mV	1
Voltage Low	V_{Low}		-150	14	150		1
Max Voltage	V_{max}	Measurement on single ended signal using absolute value. (Scope averaging off)		806	1150	mV	1
Min Voltage	V_{min}		-300	-1			1
Vswing	V_{swing}	Scope averaging off (Differential)	300	1552		mV	1, 2
Crossing Voltage (abs)	V_{cross_abs}	Scope averaging off	250	375	550	mV	1, 5
Crossing Voltage (var)	ΔV_{cross}	Scope averaging off		18	140	mV	1, 6

¹ Guaranteed by design and characterization, not 100% tested in production. $I_{REF} = V_{DD}/(3 \times R_R)$. For $R_R = 475\Omega$ (1%), $I_{REF} = 2.32\text{mA}$. $I_{OH} = 6 \times I_{REF}$ and $V_{OH} = 0.7\text{V}$ @ $Z_O = 50\Omega$ (100 Ω differential impedance).

² Measured from differential waveform

³ Slew rate is measured through the V_{swing} voltage range centered around differential 0V. This results in a +/-150mV window around differential 0V.

⁴ Matching applies to rising edge rate for Clock and falling edge rate for Clock#. It is measured using a +/-75mV window centered on the average cross point where Clock rising meets Clock# falling. The median cross point is used to calculate the voltage thresholds the oscilloscope is to use for the edge rate calculations.

⁵ V_{cross} is defined as voltage where Clock = Clock# measured on a component test board and only applies to the differential rising edge (i.e. Clock rising and Clock# falling).

⁶ The total variation of all V_{cross} measurements in any particular system. Note that this is a subset of V_{cross_min}/max (V_{cross} absolute) allowed. The intent is to limit V_{cross} induced modulation by setting V_{cross_delta} to be smaller than V_{cross} absolute.

Electrical Characteristics–Output Duty Cycle, Jitter, Skew and PLL Characteristics

$T_A = T_{COM}$ or T_{IND} ; Supply Voltage $V_{DD} = 3.3\text{ V} \pm 5\%$

PARAMETER	SYMBOL	CONDITIONS	MIN	TYP	MAX	UNITS	NOTES
PLL Bandwidth	BW	-3dB point in High BW Mode (T_{IND})	1.5	2.7	4.1	MHz	1
		-3dB point in High BW Mode (T_{COM})	2	2.7	4	MHz	1
		-3dB point in Low BW Mode	0.7	1.1	1.4	MHz	1
PLL Jitter Peaking	t_{JPEAK}	Peak Pass band Gain		1.5	2	dB	1
Duty Cycle	t_{DC}	Measured differentially, PLL Mode	45	49	55	%	1
Duty Cycle Distortion	t_{DCD}	Measured differentially, Bypass Mode @100MHz	-2		2	%	1,4
Skew, Input to Output	t_{pdBYP}	Bypass Mode, $V_T = 50\%$ (T_{IND})	2500		4900	ps	1
		Bypass Mode, $V_T = 50\%$ (T_{COM})	2500		4500	ps	1,5
	t_{pdPLL}	PLL Mode $V_T = 50\%$	-250	-50	250	ps	1
Skew, Output to Output	t_{sk3}	$V_T = 50\%$			50/60	ps	1,5
Jitter, Cycle to cycle	$t_{jcc-cyc}$	PLL mode			50	ps	1,3
		Additive Jitter in Bypass Mode			50	ps	1,3

¹ Guaranteed by design and characterization, not 100% tested in production.

² $I_{REF} = V_{DD}/(3 \times R_R)$. For $R_R = 475\Omega$ (1%), $I_{REF} = 2.32\text{mA}$. $I_{OH} = 6 \times I_{REF}$ and $V_{OH} = 0.7\text{V}$ @ $Z_O = 50\Omega$.

³ Measured from differential waveform

⁴ Duty cycle distortion is the difference in duty cycle between the output and the input clock when the device is operated in bypass mode.

⁵ First number is commercial temp, second number is industrial temp.

Electrical Characteristics–PCIe Phase Jitter Parameters

TA = T_{COM} or T_{IND}; Supply Voltage VDD = 3.3 V +/-5%

PARAMETER	SYMBOL	CONDITIONS	MIN	TYP	MAX	UNITS	Notes
Phase Jitter, PLL Mode	t _{jphPCIeG1}	PCIe Gen 1		30	86	ps (p-p)	1,2,3
	t _{jphPCIeG2}	PCIe Gen 2 Lo Band 10kHz < f < 1.5MHz		1.0	3	ps (rms)	1,2
		PCIe Gen 2 High Band 1.5MHz < f < Nyquist (50MHz)		2.2	3.1	ps (rms)	1,2
	t _{jphPCIeG3}	PCIe Gen 3 (PLL BW of 2-4MHz, CDR = 10MHz)		0.5	1	ps (rms)	1,2,4
Additive Phase Jitter, Bypass Mode	t _{jphPCIeG1}	PCIe Gen 1		1	5	ps (p-p)	1,2,3
	t _{jphPCIeG2}	PCIe Gen 2 Lo Band 10kHz < f < 1.5MHz		0.1	0.1	ps (rms)	1,2
		PCIe Gen 2 High Band 1.5MHz < f < Nyquist (50MHz)		0.2	0.3	ps (rms)	1,2
	t _{jphPCIeG3}	PCIe Gen 3 (PLL BW of 2-4MHz, CDR = 10MHz)		0.0	0.1	ps (rms)	1,2,4

¹ Applies to all outputs.

² See <http://www.pcisig.com> for complete specs

³ Sample size of at least 100K cycles. This figures extrapolates to 108ps pk-pk @ 1M cycles for a BER of 1-12.

⁴ Subject to final radification by PCI SIG.

Clock Periods Differential Outputs Tracking Spread Spectrum

Measurement Window	1 Clock	1us	0.1s	0.1s	0.1s	1us	1 Clock		
Symbol	Lg-	-SSC	-ppm error	0ppm	+ ppm error	+SSC	Lg+		
Definition	Absolute Period	Short-term Average	Long-Term Average	Period	Long-Term Average	Short-term Average	Period		
	Minimum Absolute Period	Minimum Absolute Period	Minimum Absolute Period	Nominal	Maximum	Maximum	Maximum	Units	Notes
DIF 100	9.949	9.999	10.024	10.025	10.026	10.051	10.101	ns	1,2,3

Clock Periods Differential Outputs not Tracking Spread Spectrum

Measurement Window	1 Clock	1us	0.1s	0.1s	0.1s	1us	1 Clock		
Symbol	Lg-	-SSC	-ppm error	0ppm	+ ppm error	+SSC	Lg+		
Definition	Absolute Period	Short-term Average	Long-Term Average	Period	Long-Term Average	Short-term Average	Period		
	Minimum Absolute Period	Minimum Absolute Period	Minimum Absolute Period	Nominal	Maximum	Maximum	Maximum	Units	Notes
DIF 100M	9.949		9.999	10.000	10.001		10.051	ns	1,2,3

¹Guaranteed by design and characterization, not 100% tested in production.

² All Long Term Accuracy specifications are guaranteed with the assumption that the input clock complies with CK410B+ accuracy requirements. The buffer itself does not contribute to ppm error.

³ Driven by PCIe output of main clock, PLL Mode or Bypass mode

Output Termination and Layout Information			
Common Recommendations for Differential Routing	Dimension or Value	Unit	Figure
L1 length, route as non-coupled 50ohm trace	0.5 max	inch	1
L2 length, route as non-coupled 50ohm trace	0.2 max	inch	1
L3 length, route as non-coupled 50ohm trace	0.2 max	inch	1
R_s	33	ohm	1
R_t	49.9	ohm	1

Down Device Differential Routing			
L4 length, route as coupled microstrip 100ohm differential trace	2 min to 16 max	inch	1
L4 length, route as coupled stripline 100ohm differential trace	1.8 min to 14.4 max	inch	1

Differential Routing to PCI Express Connector			
L4 length, route as coupled microstrip 100ohm differential trace	0.25 to 14 max	inch	2
L4 length, route as coupled stripline 100ohm differential trace	0.225 min to 12.6 max	inch	2

Figure 1: Down Device Routing

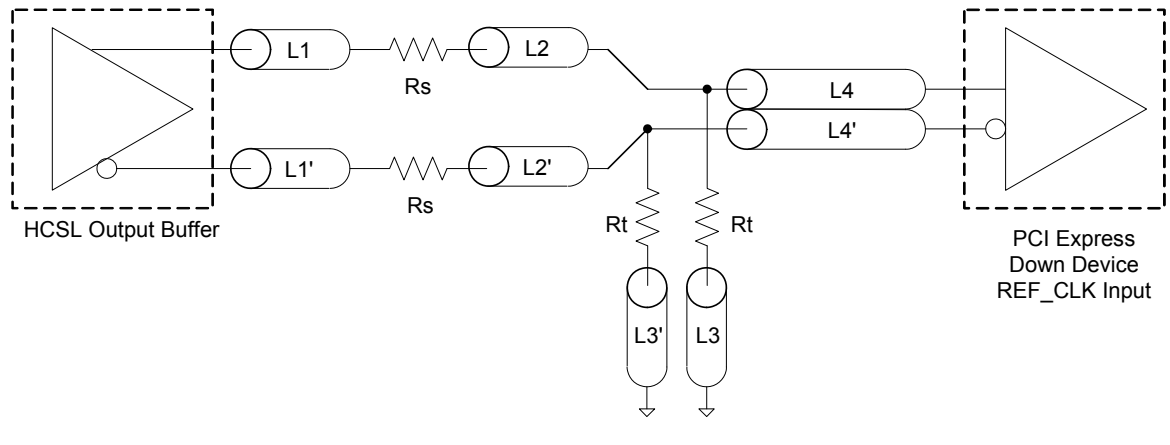
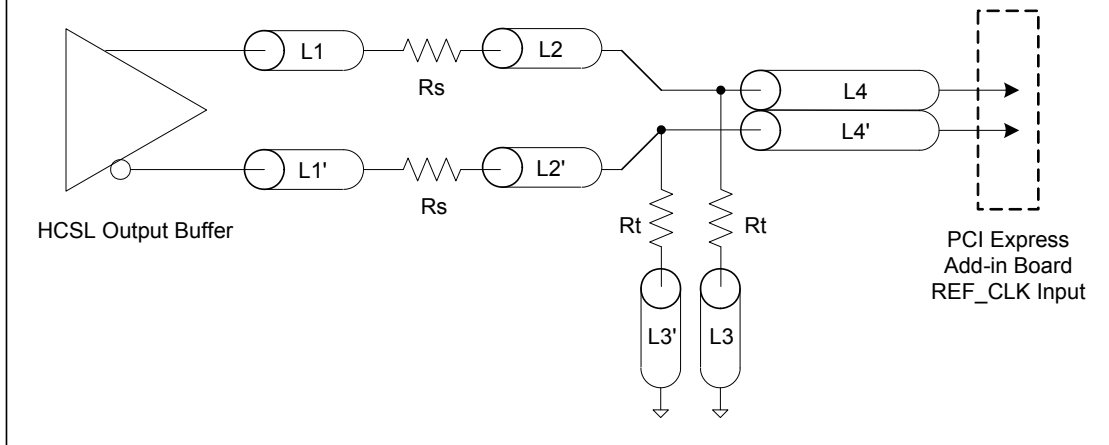
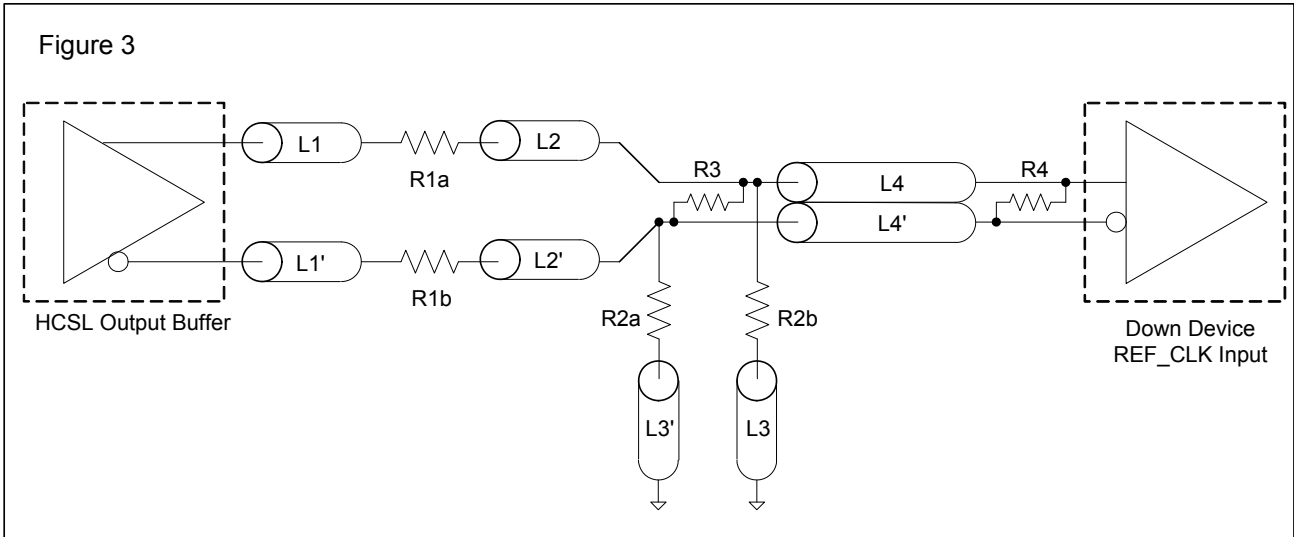

Figure 2: Differential Routing to PCI Express Controller



Termination for LVDS and other Common Differential Signals (figure 3)							
Vdiff	Vp-p	Vcm	R1	R2	R3	R4	Note
0.45v	0.22v	1.08	33	150	100	100	
0.58	0.28	0.6	33	78.7	137	100	
0.80	0.40	0.6	33	78.7	none	100	ICS874003i-02 input compatible
0.60	0.3	1.2	33	174	140	100	Standard LVDS

R1a = R1b = R1
R2a = R2b = R2



Termination for Cable AC Coupled Application (figure 4)		
Component	Value	Note
R5a, R5b	8.2K 5%	
R6a, R6b	1K 5%	
Cc	0.1 μ F	
Vcm	0.350 volts	

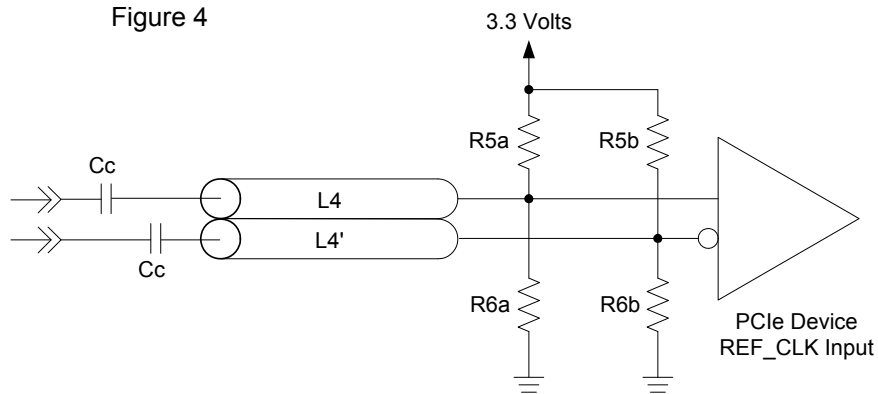

General SMBus Serial Interface Information

How to Write

- Controller (host) sends a start bit
- Controller (host) sends the write address*
- IDT clock will **acknowledge**
- Controller (host) sends the beginning byte location = N
- IDT clock will **acknowledge**
- Controller (host) sends the byte count = X
- IDT clock will **acknowledge**
- Controller (host) starts sending Byte N through Byte N+X-1
- IDT clock will **acknowledge** each byte **one at a time**
- Controller (host) sends a Stop bit

Index Block Write Operation			
Controller (Host)			IDT (Slave/Receiver)
T	starT bit		
Slave Address			
WR	WRite		
Beginning Byte = N			ACK
Data Byte Count = X			ACK
Beginning Byte N		X Byte	ACK
O			O
O			O
O			O
Byte N + X - 1			ACK
P	stoP bit		

* Assuming SMB_ADR_tri is at mid-level

Read Address	Write Address
DD _(H)	DC _(H)

How to Read

- Controller (host) will send a start bit
- Controller (host) sends the write address*
- IDT clock will **acknowledge**
- Controller (host) sends the beginning byte location = N
- IDT clock will **acknowledge**
- Controller (host) will send a separate start bit
- Controller (host) sends the read address*
- IDT clock will **acknowledge**
- IDT clock will send the data byte count = X
- IDT clock sends Byte N+X-1
- IDT clock sends **Byte 0 through Byte X (if X_(H) was written to Byte 8)**
- Controller (host) will need to acknowledge each byte
- Controller (host) will send a not acknowledge bit
- Controller (host) will send a stop bit

Index Block Read Operation			
Controller (Host)			IDT (Slave/Receiver)
T	starT bit		
Slave Address			
WR	WRite		
Beginning Byte = N			ACK
Repeat starT			ACK
Slave Address			
RD	ReaD		ACK
Data Byte Count=X			
ACK		X Byte	Beginning Byte N
ACK			O
O			O
O			O
O			
ACK			Byte N + X - 1
N	Not acknowledge		
P	stoP bit		

SMBus Table: Frequency Select Register, READ/WRITE ADDRESS (Selectable)

Byte 0	Pin #	Name	Control Function	Type	0	1	Default
Bit 7	-	PD_Mode	PD# drive mode	RW	driven	Hi-Z	1
Bit 6	-	OE_Mode	OE#_Stop drive mode	RW	driven	Hi-Z	0
Bit 5	-		Reserved				0
Bit 4	-		Reserved				X
Bit 3	-	MODE1	BYPASS#/PLL1	RW	See Operating Mode Readback Table		Input
Bit 2	-		Reserved				1
Bit 1	-	MODE0	BYPASS#/PLL0	RW	See Operating Mode Readback Table		Input
Bit 0	-	SRC_DIV#	SRC Divide by 2 Select	RW	x/2	x/1	1

SMBus Table: Output Control Register

Byte 1	Pin #	Name	Control Function	Type	0	1	Default
Bit 7	42,41	DIF_7	Output Enable	RW	Disable	Enable	1
Bit 6	38,37	DIF_6	Output Enable	RW	Disable	Enable	1
Bit 5	34,33	DIF_5	Output Enable	RW	Disable	Enable	1
Bit 4	30,29	DIF_4	Output Enable	RW	Disable	Enable	1
Bit 3	20,21	DIF_3	Output Enable	RW	Disable	Enable	1
Bit 2	16,17	DIF_2	Output Enable	RW	Disable	Enable	1
Bit 1	12,13	DIF_1	Output Enable	RW	Disable	Enable	1
Bit 0	8,9	DIF_0	Output Enable	RW	Disable	Enable	1

NOTE: The SMBus Output Enable Bit must be '1' AND the respective OE pin must be active for the output to run!

SMBus Table: OE Pin Control Register

Byte 2	Pin #	Name	Control Function	Type	0	1	Default
Bit 7	42,41	DIF_7	DIF_7 Stoppable with DIFSTOP	RW	Free-run	Stoppable	0
Bit 6	38,37	DIF_6	DIF_6 Stoppable with DIFSTOP	RW	Free-run	Stoppable	0
Bit 5	34,33	DIF_5	DIF_5 Stoppable with DIFSTOP	RW	Free-run	Stoppable	0
Bit 4	30,29	DIF_4	DIF_4 Stoppable with DIFSTOP	RW	Free-run	Stoppable	0
Bit 3	20,21	DIF_3	DIF_3 Stoppable with DIFSTOP	RW	Free-run	Stoppable	0
Bit 2	16,17	DIF_2	DIF_2 Stoppable with DIFSTOP	RW	Free-run	Stoppable	0
Bit 1	12,13	DIF_1	DIF_1 Stoppable with DIFSTOP	RW	Free-run	Stoppable	0
Bit 0	8,9	DIF_0	DIF_0 Stoppable with DIFSTOP	RW	Free-run	Stoppable	0

SMBus Table: Reserved Register

Byte 3	Pin #	Name	Control Function	Type	0	1	Default
Bit 7			Reserved				X
Bit 6			Reserved				X
Bit 5			Reserved				X
Bit 4			Reserved				X
Bit 3			Reserved				X
Bit 2			Reserved				X
Bit 1			Reserved				X
Bit 0			Reserved				X

SMBus Table: Vendor & Revision ID Register

Byte 4	Pin #	Name	Control Function	Type	0	1	Default
Bit 7	-	RID3	REVISION ID	R	-	-	0
Bit 6	-	RID2		R	-	-	0
Bit 5	-	RID1		R	-	-	0
Bit 4	-	RID0		R	-	-	0
Bit 3	-	VID3	VENDOR ID	R	-	-	0
Bit 2	-	VID2		R	-	-	0
Bit 1	-	VID1		R	-	-	0
Bit 0	-	VID0		R	-	-	1

SMBus Table: DEVICE ID

Byte 5	Pin #	Name	Control Function	Type	0	1	Default
Bit 7	-	Device ID 7 (MSB)		RW	Device ID is 83 Hex for 9DB833		1
Bit 6	-	Device ID 6		RW		0	
Bit 5	-	Device ID 5		RW		0	
Bit 4	-	Device ID 4		RW		0	
Bit 3	-	Device ID 3		RW		0	
Bit 2	-	Device ID 2		RW		0	
Bit 1	-	Device ID 1		RW		1	
Bit 0	-	Device ID 0		RW		1	

SMBus Table: Byte Count Register

Byte 6	Pin #	Name	Control Function	Type	0	1	Default
Bit 7	-	BC7	Writing to this register configures how many bytes will be read back.	RW	-	-	0
Bit 6	-	BC6		RW	-	-	0
Bit 5	-	BC5		RW	-	-	0
Bit 4	-	BC4		RW	-	-	0
Bit 3	-	BC3		RW	-	-	0
Bit 2	-	BC2		RW	-	-	1
Bit 1	-	BC1		RW	-	-	1
Bit 0	-	BC0		RW	-	-	1

PD#, Power Down

The PD# pin cleanly shuts off all clocks and places the device into a power saving mode. PD# must be asserted before shutting off the input clock or power to insure an orderly shutdown. PD is asynchronous active-low input for both powering down the device and powering up the device. When PD# is asserted, all clocks will be driven high, or tri-stated (depending on the PD# drive mode and Output control bits) before the PLL is shut down.

PD# Assertion

When PD# is sampled low by two consecutive rising edges of DIF#, all DIF outputs must be held High, or tri-stated (depending on the PD# drive mode and Output control bits) on the next High-Low transition of the DIF# outputs. When the PD# drive mode bit is set to '0', all clock outputs will be held with DIF driven High with $2 \times I_{REF}$ and DIF# tri-stated. If the PD# drive mode bit is set to '1', both DIF and DIF# are tri-stated.

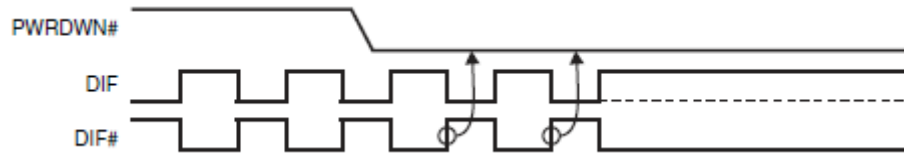

PD# De-assertion

Power-up latency is less than 1 ms. This is the time from de-assertion of the PD# pin, or VDD reaching 3.3V, or the time from valid SRC_IN clocks until the time that stable clocks are output from the device (PLL Locked). If the PD# drive mode bit is set to '1', all the DIF outputs must driven to a voltage of >200 mV within $300 \mu\text{s}$ of PD# de-assertion.

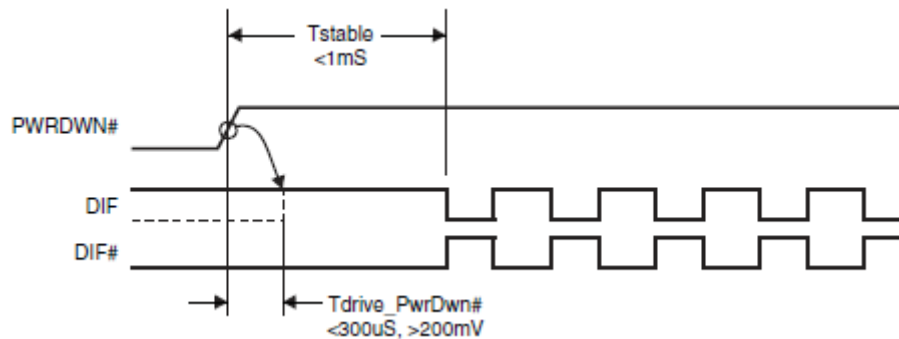

Package Outline and Package Dimensions (48-pin TSSOP)

Package dimensions are kept current with JEDEC Publication No. 95

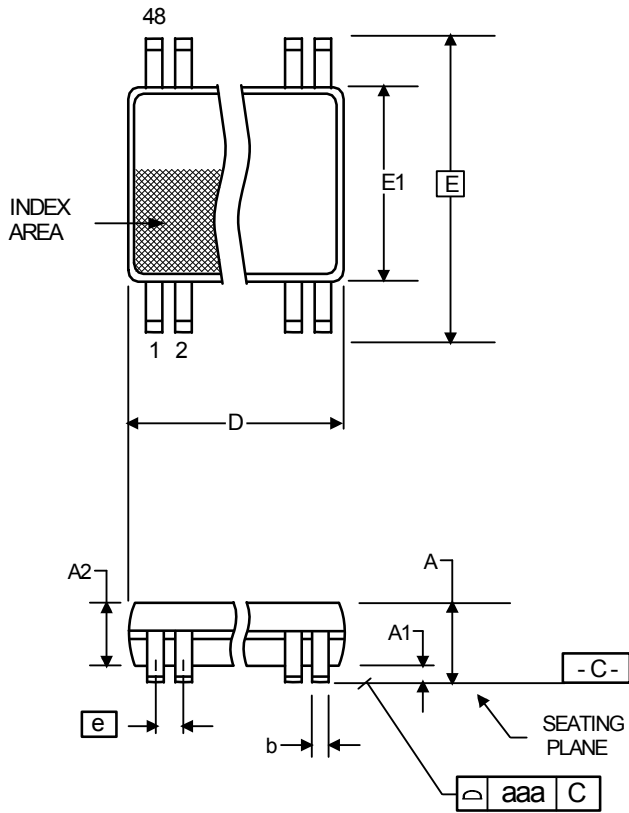

Symbol	Millimeters		Inches*	
	Min	Max	Min	Max
A	--	1.20	--	0.047
A1	0.05	0.15	0.002	0.006
A2	0.80	1.05	0.032	0.041
b	0.17	0.27	0.007	0.011
c	0.09	0.20	0.0035	0.008
D	12.40	12.60	0.488	0.496
E	8.10 BASIC		0.319 BASIC	
E1	6.00	6.20	0.236	0.244
e	0.50 Basic		0.020 Basic	
L	0.45	0.75	0.018	0.030
α	0°	8°	0°	8°
aaa	--	0.10	--	0.004

*For reference only. Controlling dimensions in mm.

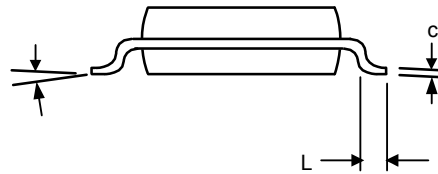

Package Outline and Package Dimensions (48-pin SSOP)

Package dimensions are kept current with JEDEC Publication No. 95

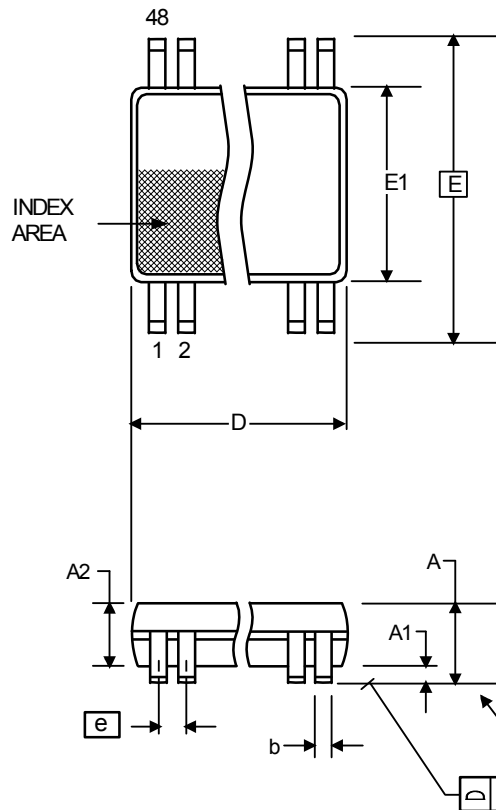

Symbol	Millimeters		Inches*	
	Min	Max	Min	Max
A	2.41	2.80	.095	.110
A1	0.20	0.40	.008	.016
b	0.20	0.34	.008	.0135
c	0.13	0.25	.005	.010
D	15.75	16.00	.620	.630
E	10.03	10.68	.395	.420
E1	7.40	7.60	.291	.299
e	0.635 BASIC		0.025 BASIC	
h	0.38	0.64	.015	.025
L	0.50	1.02	.020	.040
α	0°	8°	0°	8°

*For reference only. Controlling dimensions in mm.

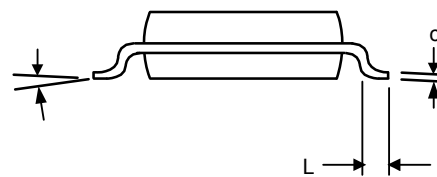

Ordering Information

Part / Order Number	Shipping Packaging	Package	Temperature
9DB833AFLF	Tubes	48-pin SSOP	0 to +70°C
9DB833AFLFT	Tape and Reel	48-pin SSOP	0 to +70°C
9DB833AGLF	Tubes	48-pin TSSOP	0 to +70°C
9DB833AGLFT	Tape and Reel	48-pin TSSOP	0 to +70°C
9DB833AFILF	Tubes	48-pin SSOP	-40 to +85°C
9DB833AFILFT	Tape and Reel	48-pin SSOP	-40 to +85°C
9DB833AGILF	Tubes	48-pin TSSOP	-40 to +85°C
9DB833AGILFT	Tape and Reel	48-pin TSSOP	-40 to +85°C

"LF" suffix to the part number are the Pb-Free configuration and are RoHS compliant.

"A" is the device revision designator (will not correlate with the datasheet revision).

While the information presented herein has been checked for both accuracy and reliability, Integrated Device Technology (IDT) assumes no responsibility for either its use or for the infringement of any patents or other rights of third parties, which would result from its use. No other circuits, patents, or licenses are implied. This product is intended for use in normal commercial applications. Any other applications such as those requiring extended temperature range, high reliability, or other extraordinary environmental requirements are not recommended without additional processing by IDT. IDT reserves the right to change any circuitry or specifications without notice. IDT does not authorize or warrant any IDT product for use in life support devices or critical medical instruments.

Revision History

Rev.	Issue Date	Who	Description	Page #
A	6/30/2010	RDW	Released to final	
B	5/9/2011	RDW	1. Update pin 2 pin-name and pin description from VDD to VDDR. This highlights that optimal performance is obtained by treating VDDR as in analog pin. This is a document update only, there is no silicon change.	Various
C	5/24/2011	RDW	1. Corrected pin description of Pins 27/28 2. Corrected orderable part number for 9DB833AGILFT	
D	3/13/2012	RW	1. Added additional line to PLL Bandwidth "-3dB point in High BW Mode" conditions for industrial mode (min1.5, typ 2.7, max 4.1 MHz) 2. Added additional line to Skew, Input to Output "Bypass Mode" conditions for industrial mode (min 2500, max 4900 ps)	6
E	7/5/2012	RW	1. Changed references of PCIe Gen3 to PCIe Gen1,2,3 2. Corrected Power Connections Table - pinout was/is correct.	1, 2
F	9/18/2012	RW	Updated Byte 2, bits 1, 2, 5 and 6 per char review. Outputs can be programmed with Byte 2 to be Stoppable or Free-Run with DIF_Stop pin, not the OE pins.	12

Innovate with IDT and accelerate your future networks. Contact:

www.IDT.com

For Sales

800-345-7015
408-284-8200
Fax: 408-284-2775

For Tech Support

www.idt.com/go/clockhelp
pcclockhelp@idt.com

Corporate Headquarters

Integrated Device Technology, Inc.
www.idt.com

