



General Description

The 9DB433 zero-delay buffer supports PCIe Gen3 requirements, while being backwards compatible to PCIe Gen2 and Gen1. The 9DB433 is driven by a differential SRC output pair from an IDT 932S421 or 932SQ420 or equivalent main clock generator.

Recommended Application

4 output PCIe Gen1,2,3 zero-delay/fanout buffer

Key Specifications

- Output cycle-cycle jitter <50ps
- Output to Output skew <50ps
- Phase jitter: PCIe Gen3 <1.0ps rms

Features/Benefits

- 3 Selectable SMBus Addresses; Multiple devices can share the same SMBus Segment
- OE# pins; Suitable for Express Card applications
- PLL or bypass mode; PLL can de-jitter incoming clock
- Selectable PLL bandwidth; minimizes jitter peaking in downstream PLL's
- Spread Spectrum Compatible; tracks spreading input clock for low EMI
- SMBus Interface; unused outputs can be disabled
- Supports undriven differential outputs in Power Down mode for power management

Output Features

- 4 - 0.7V current-mode differential HCSL output pairs
- Supports zero delay buffer mode and fanout mode
- Selectable bandwidth
- 50-110 MHz operation in PLL mode
- 5-166 MHz operation in Bypass mode

Functional Block Diagram

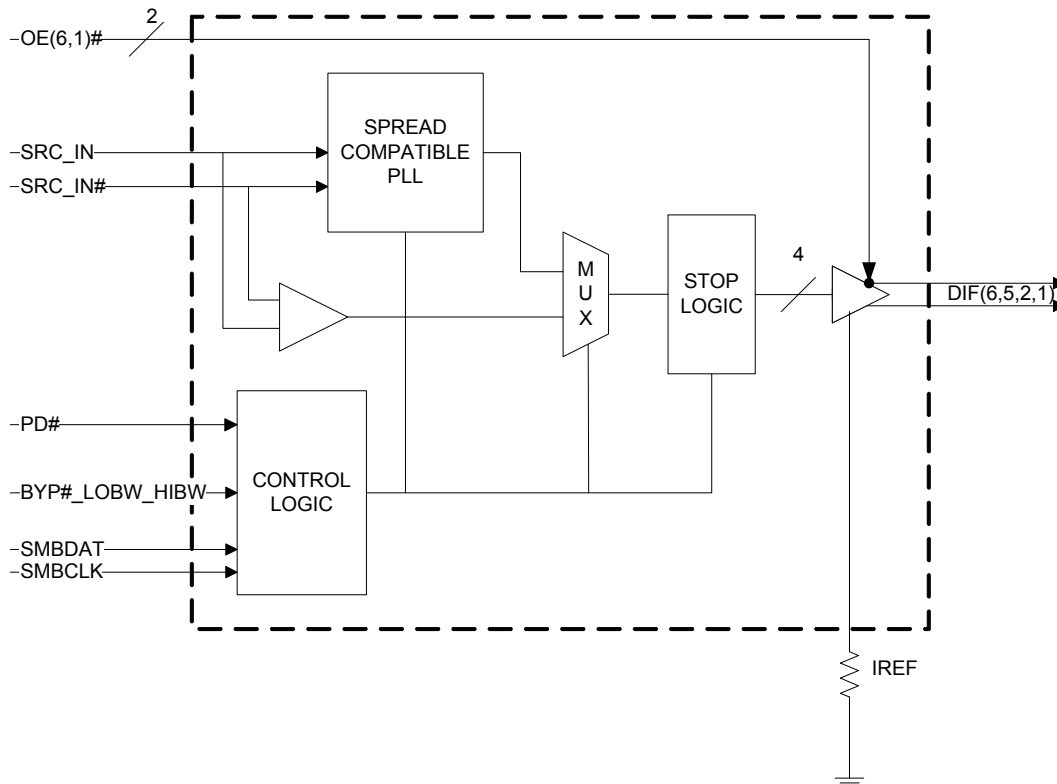

Pin Configuration

VDDR	1	9DB433	28	VDDA
SRC_IN	2		27	GNDA
SRC_IN#	3		26	IREF
GND	4		25	PD#
VDD	5		24	VDD
DIF_1	6		23	DIF_6
DIF_1#	7		22	DIF_6#
OE1#	8		21	OE6#
DIF_2	9		20	DIF_5
DIF_2#	10		19	DIF_5#
VDD	11		18	VDD
BYP#_HIBW_LOBW	12		17	SMB_ADR_tri
SMBCLK	13		16	VDD
SMBDAT	14		15	GND

Notes:

Highlighted Pins are the differences between 9DB403 and 9DB433.

Pin 12 and Pin 17 are latched on power up. Please make sure that the power supply to the pullup/pulldown resistors ramps at the same time as the main supply to the chip.

SMBus Address Selection and Readback

SMB_ADR_tri	Address
Low	DA/DB
Mid	DC/DD
High	D8/D9

PLL Operating Mode Readback Table

BYP#_LOBW_HIBW	MODE	Byte0, bit 3	Byte 0 bit 1
Low	Bypass	0	0
Mid	PLL 100M Hi BW	1	0
High	PLL 100M Low BW	0	1

Power Groups

Pin Number		Description
VDD	GND	
1	4	SRC_IN/SRC_IN#
5,11,18, 24	4	DIF(1,2,5,6)
16	15	DIGITAL VDD/GND
28	27	Analog VDD/GND for PLL in IREF

For best results, treat pin 1 as analog VDD.

Tri-Level Input Logic Pins

State of Pin	Voltage
Low	<0.8V
Mid	1.2<Vin<1.8V
High	Vin > 2.0V

Pin Descriptions

PIN #	PIN NAME	PIN TYPE	DESCRIPTION
1	VDDR	PWR	3.3V power for differential input clock (receiver). This VDD should be treated as an analog power rail and filtered appropriately.
2	SRC_IN	IN	0.7 V Differential SRC TRUE input
3	SRC_IN#	IN	0.7 V Differential SRC COMPLEMENTARY input
4	GND	PWR	Ground pin.
5	VDD	PWR	Power supply, nominal 3.3V
6	DIF_1	OUT	0.7V differential true clock output
7	DIF_1#	OUT	0.7V differential Complementary clock output
8	OE1#	IN	Active low input for enabling DIF pair 1. 1 =disable outputs, 0 = enable outputs
9	DIF_2	OUT	0.7V differential true clock output
10	DIF_2#	OUT	0.7V differential Complementary clock output
11	VDD	PWR	Power supply, nominal 3.3V
12	BYP#_HIBW_LOBW	IN	Tri-level input to select bypass mode, Hi BW PLL, or Lo BW PLL mode
13	SMBCLK	IN	Clock pin of SMBUS circuitry, 5V tolerant
14	SMBDAT	I/O	Data pin of SMBUS circuitry, 5V tolerant
15	GND	PWR	Ground pin.
16	VDD	PWR	Power supply, nominal 3.3V
17	SMB_ADR_tri	IN	SMBus address select bit. This is a tri-level input that decodes 1 of 3 SMBus Addresses.
18	VDD	PWR	Power supply, nominal 3.3V
19	DIF_5#	OUT	0.7V differential Complementary clock output
20	DIF_5	OUT	0.7V differential true clock output
21	OE6#	IN	Active low input for enabling DIF pair 6. 1 =disable outputs, 0 = enable outputs
22	DIF_6#	OUT	0.7V differential Complementary clock output
23	DIF_6	OUT	0.7V differential true clock output
24	VDD	PWR	Power supply, nominal 3.3V
25	PD#	IN	Asynchronous active low input pin used to power down the device. The internal clocks are disabled and the VCO and the crystal osc. (if any) are stopped.
26	IREF	OUT	This pin establishes the reference for the differential current-mode output pairs. It requires a fixed precision resistor to ground. 475ohm is the standard value for 100ohm differential impedance. Other impedances require different values. See data sheet.
27	GND_A	PWR	Ground pin for the PLL core.
28	VDD_A	PWR	3.3V power for the PLL core.

Absolute Maximum Ratings

Stresses above the ratings listed below can cause permanent damage to the 9DB433. These ratings, which are standard values for IDT commercially rated parts, are stress ratings only. Functional operation of the device at these or any other conditions above those indicated in the operational sections of the specifications is not implied. Exposure to absolute maximum rating conditions for extended periods can affect product reliability. Electrical parameters are guaranteed only over the recommended operating temperature range.

PARAMETER	SYMBOL	CONDITIONS	MIN	TYP	MAX	UNITS	NOTES
3.3V Core Supply Voltage	VDDA/R				4.6	V	1,2
3.3V Logic Supply Voltage	VDD				4.6	V	1,2
Input Low Voltage	V _{IL}		GND-0.5			V	1
Input High Voltage	V _{IH}	Except for SMBus interface			V _{DD} +0.5V	V	1
Input High Voltage	V _{IHSMB}	SMBus clock and data pins			5.5V	V	1
Storage Temperature	T _s		-65		150	°C	1
Junction Temperature	T _j				125	°C	1
Input ESD protection	ESD prot	Human Body Model	2000			V	1

¹Guaranteed by design and characterization, not 100% tested in production.

²Operation under these conditions is neither implied nor guaranteed.

Electrical Characteristics—DIF 0.7V Current Mode Differential Outputs

T_A = T_{COM} or T_{IND}; Supply Voltage VDD = 3.3 V +/-5%

PARAMETER	SYMBOL	CONDITIONS	MIN	TYP	MAX	UNITS	NOTES
Slew rate	Trf	Scope averaging on	1	2	4	V/ns	1, 2, 3
Slew rate matching	ΔTrf	Slew rate matching, Scope averaging on			20	%	1, 2, 4
Voltage High	V _{High}	Statistical measurement on single-ended signal using oscilloscope math function. (Scope averaging on)	660	800	850	mV	1
Voltage Low	V _{Low}		-150	14	150		1
Max Voltage	V _{max}	Measurement on single ended signal using absolute value. (Scope averaging off)		806	1150	mV	1
Min Voltage	V _{min}		-300	-1			1
V _{swing}	V _{swing}	Scope averaging off (Differential)	300	1552		mV	1, 2
Crossing Voltage (abs)	V _{cross_abs}	Scope averaging off	250	375	550	mV	1, 5
Crossing Voltage (var)	ΔV _{cross}	Scope averaging off		18	140	mV	1, 6

¹Guaranteed by design and characterization, not 100% tested in production. I_{REF} = VDD/(3xR_R). For R_R = 475Ω (1%), I_{REF} = 2.32mA.

I_{OH} = 6 x I_{REF} and V_{OH} = 0.7V @ Z_O=50Ω (100Ω differential impedance).

² Measured from differential waveform

³ Slew rate is measured through the V_{swing} voltage range centered around differential 0V. This results in a +/-150mV window around differential 0V.

⁴ Matching applies to rising edge rate for Clock and falling edge rate for Clock#. It is measured using a +/-75mV window centered on the average cross point where Clock rising meets Clock# falling. The median cross point is used to calculate the voltage thresholds the oscilloscope is to use for the edge rate calculations.

⁵ V_{cross} is defined as voltage where Clock = Clock# measured on a component test board and only applies to the differential rising edge (i.e. Clock rising and Clock# falling).

⁶ The total variation of all V_{cross} measurements in any particular system. Note that this is a subset of V_{cross_min/max} (V_{cross} absolute) allowed. The intent is to limit V_{cross} induced modulation by setting V_{cross_delta} to be smaller than V_{cross} absolute.

Electrical Characteristics–Input/Supply/Common Parameters

TA = T_{COM} or T_{IND}; Supply Voltage VDD = 3.3 V +/-5%

PARAMETER	SYMBOL	CONDITIONS	MIN	TYP	MAX	UNITS	NOTES
Ambient Operating Temperature	T _{COM}	Commercial range	0		70	°C	1
	T _{IND}	Industrial range	-40		85	°C	1
Input High Voltage	V _{IH}	Single-ended inputs, except SMBus, low threshold and tri-level inputs	2		V _{DD} + 0.3	V	1
Input Low Voltage	V _{IL}	Single-ended inputs, except SMBus, low threshold and tri-level inputs	GND - 0.3		0.8	V	1
Input Current	I _{IN}	Single-ended inputs, V _{IN} = GND, V _{IN} = VDD	-5	-0.02	5	uA	1
	I _{INP}	Single-ended inputs V _{IN} = 0 V; Inputs with internal pull-up resistors V _{IN} = VDD; Inputs with internal pull-down resistors	-200		200	uA	1
Input Frequency	F _{ibyp}	V _{DD} = 3.3 V, Bypass mode	5		166	MHz	2
	F _{ipll}	V _{DD} = 3.3 V, 100MHz PLL mode	50	100	110	MHz	2
Pin Inductance	L _{pin}				7	nH	1
Capacitance	C _{IN}	Logic Inputs, except DIF_IN	1.5		5	pF	1
	C _{INDIF_IN}	DIF_IN differential clock inputs	1.5		2.7	pF	1,4
	C _{OUT}	Output pin capacitance			6	pF	1
Clk Stabilization	T _{STAB}	From V _{DD} Power-Up and after input clock stabilization or de-assertion of PD# to 1st clock			1	ms	1,2
Input SS Modulation Frequency	f _{MODIN}	Allowable Frequency (Triangular Modulation)	30	31.5	33	kHz	1
OE# Latency	t _{LATOE#}	DIF start after OE# assertion DIF stop after OE# deassertion	1	2	3	cycles	1,3
Tdrive_PD#	t _{DRVDPD}	DIF output enable after PD# de-assertion		13	300	us	1,3
Tfall	t _F	Fall time of control inputs			5	ns	1,2
Trise	t _R	Rise time of control inputs			5	ns	1,2
SMBus Input Low Voltage	V _{ILSMB}				0.8	V	1
SMBus Input High Voltage	V _{IHSMB}		2.1		V _{DD} SMB	V	1
SMBus Output Low Voltage	V _{OLSMB}	@ I _{PULLUP}			0.4	V	1
SMBus Sink Current	I _{PULLUP}	@ V _{OL}	4			mA	1
Nominal Bus Voltage	V _{DD} SMB	3V to 5V +/- 10%	2.7		5.5	V	1
SCLK/SDATA Rise Time	t _{RSMB}	(Max VIL - 0.15) to (Min VIH + 0.15)			1000	ns	1
SCLK/SDATA Fall Time	t _{FSMB}	(Min VIH + 0.15) to (Max VIL - 0.15)			300	ns	1
SMBus Operating Frequency	f _{MAXSMB}	Maximum SMBus operating frequency			100	kHz	1,5

¹Guaranteed by design and characterization, not 100% tested in production.

²Control input must be monotonic from 20% to 80% of input swing.

³Time from deassertion until outputs are >200 mV

⁴DIF_IN input

⁵The differential input clock must be running for the SMBus to be active

Electrical Characteristics–Clock Input Parameters

TA = T_{COM} or T_{IND}; Supply Voltage VDD = 3.3 V +/-5%

PARAMETER	SYMBOL	CONDITIONS	MIN	TYP	MAX	UNITS	NOTES
Input High Voltage - DIF_IN	V _{IHDIF}	Differential inputs (single-ended measurement)	600	800	1150	mV	1
Input Low Voltage - DIF_IN	V _{ILDIF}	Differential inputs (single-ended measurement)	V _{SS} - 300	0	300	mV	1
Input Common Mode Voltage - DIF_IN	V _{COM}	Common Mode Input Voltage	300		1000	mV	1
Input Amplitude - DIF_IN	V _{SWING}	Peak to Peak value (single-ended)	300		1450	mV	1
Input Slew Rate - DIF_IN	dv/dt	Measured differentially	1		8	V/ns	1,2
Input Leakage Current	I _{IN}	V _{IN} = V _{DD} , V _{IN} = GND	-5	-0.02	5	uA	1
Input Duty Cycle	d _{in}	Measurement from differential waveform	45	50	55	%	1
Input Jitter - Cycle to Cycle	J _{DIFin}	Differential Measurement	0		125	ps	1

¹ Guaranteed by design and characterization, not 100% tested in production.

² Slew rate measured through +/-75mV window centered around differential zero

Electrical Characteristics–Current Consumption

TA = T_{COM} or T_{IND}; Supply Voltage VDD = 3.3 V +/-5%

PARAMETER	SYMBOL	CONDITIONS	MIN	TYP	MAX	UNITS	NOTES
Operating Supply Current	I _{DD3.3OP}	All outputs active @100MHz, C _L = Full load;		170	200	mA	1
Powerdown Current	I _{DD3.3PD}	All diff pairs driven		53	60	mA	1
	I _{DD3.3PDZ}	All differential pairs tri-stated		3	6	mA	1

¹ Guaranteed by design and characterization, not 100% tested in production.

Electrical Characteristics–Output Duty Cycle, Jitter, Skew and PLL Characteristics

TA = T_{COM} or T_{IND}; Supply Voltage VDD = 3.3 V +/-5%

PARAMETER	SYMBOL	CONDITIONS	MIN	TYP	MAX	UNITS	NOTES
PLL Bandwidth	BW	-3dB point in High BW Mode (T _{IND})	1.5	2.7	4.1	MHz	1
		-3dB point in High BW Mode (T _{COM})	2	2.7	4	MHz	1
		-3dB point in Low BW Mode	0.7	1.1	1.4	MHz	1
PLL Jitter Peaking	t _{JPEAK}	Peak Pass band Gain		1.5	2	dB	1
Duty Cycle	t _{DC}	Measured differentially, PLL Mode	45	49	55	%	1
Duty Cycle Distortion	t _{DCD}	Measured differentially, Bypass Mode @100MHz	-2		2	%	1,4
Skew, Input to Output	t _{pdBYP}	Bypass Mode, V _T = 50% (T _{IND})	2500		4900	ps	1
		Bypass Mode, V _T = 50% (T _{COM})	2500		4500	ps	1,5
		PLL Mode V _T = 50%	-250	-50	250	ps	1
Skew, Output to Output	t _{sk3}	V _T = 50%			50/60	ps	1,5
Jitter, Cycle to cycle	t _{jcy-cyc}	PLL mode			50	ps	1,3
		Additive Jitter in Bypass Mode			50	ps	1,3

¹ Guaranteed by design and characterization, not 100% tested in production.

² I_{REF} = V_{DD}/(3xR_R). For R_R = 475Ω (1%), I_{REF} = 2.32mA. I_{OH} = 6 x I_{REF} and V_{OH} = 0.7V @ Z_O=50Ω.

³ Measured from differential waveform

⁴ Duty cycle distortion is the difference in duty cycle between the output and the input clock when the device is operated in bypass mode.

⁵ First number is commercial temp, second number is industrial temp.

Electrical Characteristics–PCIe Phase Jitter Parameters

TA = T_{COM} or T_{IND}; Supply Voltage VDD = 3.3 V +/-5%

PARAMETER	SYMBOL	CONDITIONS	MIN	TYP	MAX	UNITS	Notes
Phase Jitter, PLL Mode	t _{jphPCIeG1}	PCIe Gen 1		30	86	ps (p-p)	1,2,3
	t _{jphPCIeG2}	PCIe Gen 2 Lo Band 10kHz < f < 1.5MHz		1.0	3	ps (rms)	1,2
		PCIe Gen 2 High Band 1.5MHz < f < Nyquist (50MHz)		2.2	3.1	ps (rms)	1,2
	t _{jphPCIeG3}	PCIe Gen 3 (PLL BW of 2-4MHz, CDR = 10MHz)		0.5	1	ps (rms)	1,2,4
Additive Phase Jitter, Bypass Mode	t _{jphPCIeG1}	PCIe Gen 1		1	5	ps (p-p)	1,2,3
	t _{jphPCIeG2}	PCIe Gen 2 Lo Band 10kHz < f < 1.5MHz		0.1	0.1	ps (rms)	1,2
		PCIe Gen 2 High Band 1.5MHz < f < Nyquist (50MHz)		0.2	0.3	ps (rms)	1,2
	t _{jphPCIeG3}	PCIe Gen 3 (PLL BW of 2-4MHz, CDR = 10MHz)		0.0	0.1	ps (rms)	1,2,4

¹ Applies to all outputs.

² See <http://www.pcisig.com> for complete specs

³ Sample size of at least 100K cycles. This figures extrapolates to 108ps pk-pk @ 1M cycles for a BER of 1-12.

⁴ Subject to final radification by PCI SIG.

Clock Periods–Differential Outputs Tracking Spread Spectrum

Measurement Window	1 Clock	1us	0.1s	0.1s	0.1s	1us	1 Clock		
Symbol	Lg-	-SSC	-ppm error	0ppm	+ ppm error	+SSC	Lg+		
Definition	Absolute Period	Short-term Average	Long-Term Average	Period	Long-Term Average	Short-term Average	Period		
	Minimum Absolute Period	Minimum Absolute Period	Minimum Absolute Period	Nominal	Maximum	Maximum	Maximum	Units	Notes
DIF 100	9.949	9.999	10.024	10.025	10.026	10.051	10.101	ns	1,2,3

Clock Periods–Differential Outputs not Tracking Spread Spectrum

Measurement Window	1 Clock	1us	0.1s	0.1s	0.1s	1us	1 Clock		
Symbol	Lg-	-SSC	-ppm error	0ppm	+ ppm error	+SSC	Lg+		
Definition	Absolute Period	Short-term Average	Long-Term Average	Period	Long-Term Average	Short-term Average	Period		
	Minimum Absolute Period	Minimum Absolute Period	Minimum Absolute Period	Nominal	Maximum	Maximum	Maximum	Units	Notes
DIF 100M	9.949		9.999	10.000	10.001		10.051	ns	1,2,3

¹Guaranteed by design and characterization, not 100% tested in production.

² All Long Term Accuracy specifications are guaranteed with the assumption that the input clock complies with CK410B+ accuracy requirements. The buffer itself does not contribute to ppm error.

³ Driven by PCIe output of main clock, PLL Mode or Bypass mode

Output Termination and Layout Information			
Common Recommendations for Differential Routing	Dimension or Value	Unit	Figure
L1 length, route as non-coupled 50ohm trace	0.5 max	inch	1
L2 length, route as non-coupled 50ohm trace	0.2 max	inch	1
L3 length, route as non-coupled 50ohm trace	0.2 max	inch	1
R_s	33	ohm	1
R_t	49.9	ohm	1

Down Device Differential Routing			
L4 length, route as coupled microstrip 100ohm differential trace	2 min to 16 max	inch	1
L4 length, route as coupled stripline 100ohm differential trace	1.8 min to 14.4 max	inch	1

Differential Routing to PCI Express Connector			
L4 length, route as coupled microstrip 100ohm differential trace	0.25 to 14 max	inch	2
L4 length, route as coupled stripline 100ohm differential trace	0.225 min to 12.6 max	inch	2

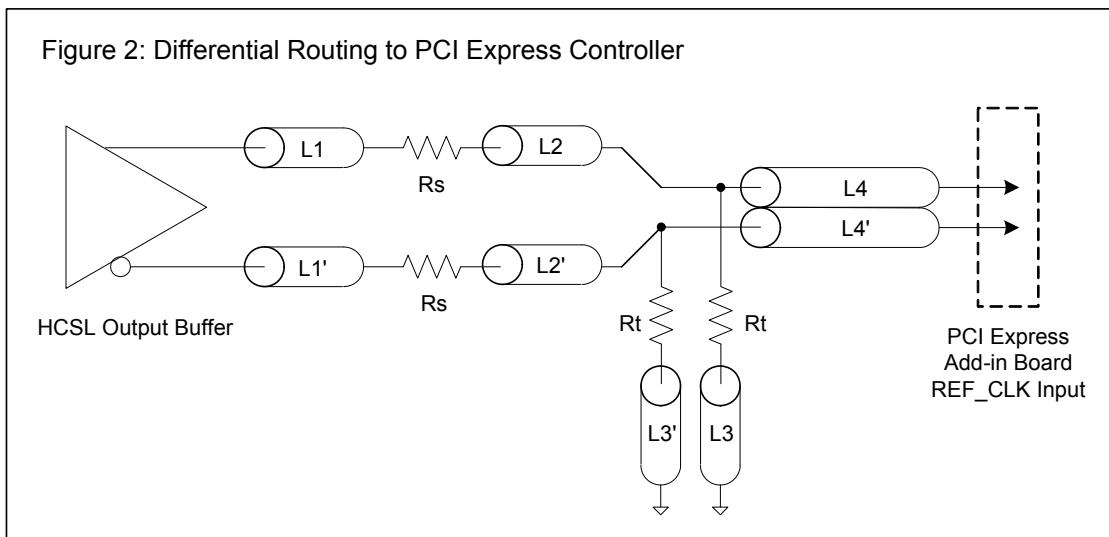
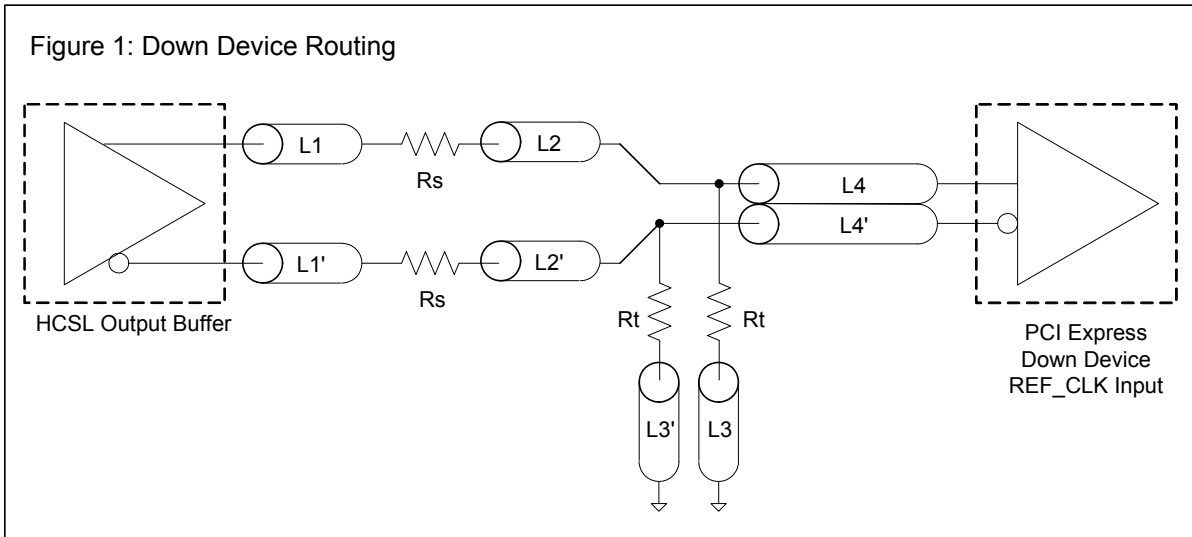

Termination for LVDS and other Common Differential Signals (figure 3)							
V _{diff}	V _{p-p}	V _{cm}	R1	R2	R3	R4	Note
0.45v	0.22v	1.08	33	150	100	100	
0.58	0.28	0.6	33	78.7	137	100	
0.80	0.40	0.6	33	78.7	none	100	ICS874003i-02 input compatible
0.60	0.3	1.2	33	174	140	100	Standard LVDS

R1a = R1b = R1

R2a = R2b = R2

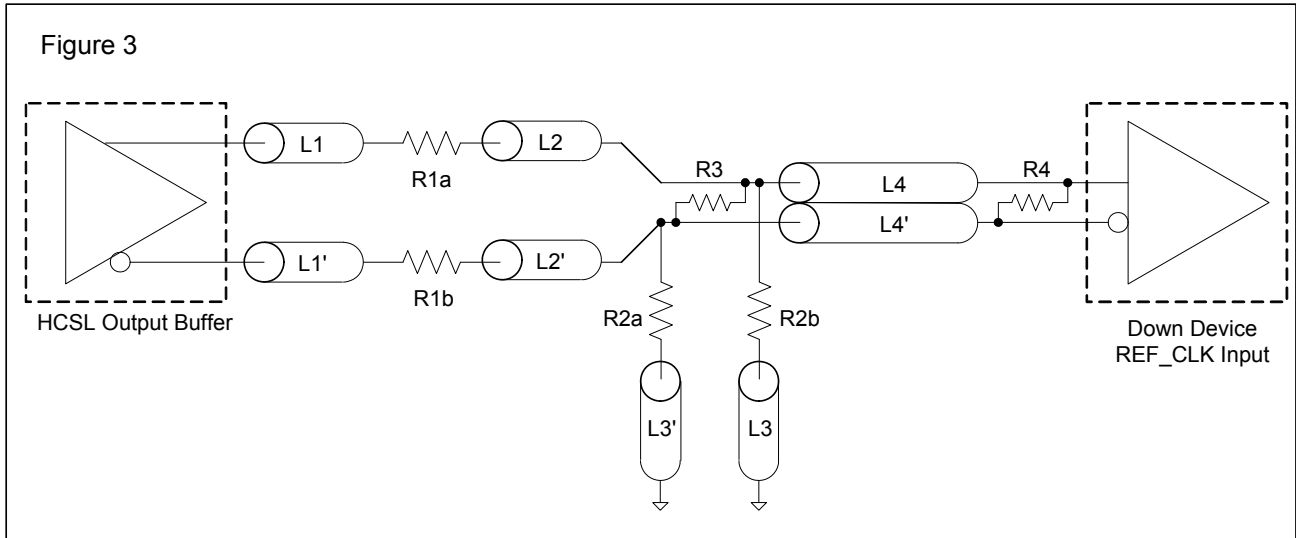

Termination for Cable AC Coupled Application (figure 4)		
Component	Value	Note
R5a, R5b	8.2K 5%	
R6a, R6b	1K 5%	
Cc	0.1 μ F	
V _{cm}	0.350 volts	

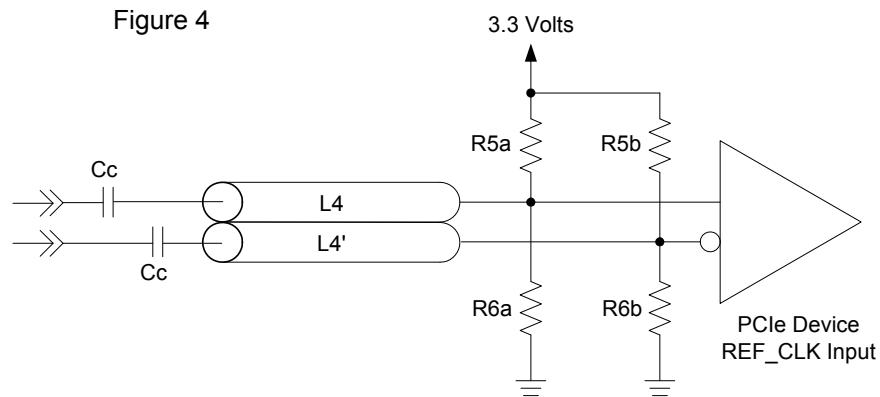

General SMBus Serial Interface Information for 9DB433

How to Write

- Controller (host) sends a start bit
- Controller (host) sends the write address
- IDT clock will **acknowledge**
- Controller (host) sends the beginning byte location = N
- IDT clock will **acknowledge**
- Controller (host) sends the byte count = X
- IDT clock will **acknowledge**
- Controller (host) starts sending Byte N through Byte N+X-1
- IDT clock will **acknowledge** each byte **one at a time**
- Controller (host) sends a Stop bit

Index Block Write Operation			
Controller (Host)		IDT (Slave/Receiver)	
T	starT bit		
Slave Address			
WR	WRite		
			ACK
Beginning Byte = N			ACK
Data Byte Count = X			ACK
Beginning Byte N		X Byte	ACK
O			O
O			O
O			O
Byte N + X - 1			ACK
P	stoP bit		

Read Address	Write Address
DD* _(H)	DC* _(H)

*Assuming SMB_ADR_tri is at mid-level

How to Read

- Controller (host) will send a start bit
- Controller (host) sends the write address
- IDT clock will **acknowledge**
- Controller (host) sends the beginning byte location = N
- IDT clock will **acknowledge**
- Controller (host) will send a separate start bit
- Controller (host) sends the read address
- IDT clock will **acknowledge**
- IDT clock will send the data byte count = X
- IDT clock sends Byte N+X-1
- IDT clock sends **Byte 0 through Byte X (if X_(H) was written to Byte 8)**
- Controller (host) will need to acknowledge each byte
- Controller (host) will send a not acknowledge bit
- Controller (host) will send a stop bit

Index Block Read Operation			
Controller (Host)		IDT (Slave/Receiver)	
T	starT bit		
Slave Address			
WR	WRite		
			ACK
Beginning Byte = N			ACK
RT Repeat starT			ACK
Slave Address			
RD	ReaD		
			ACK
ACK			Data Byte Count=X
ACK		X Byte	Beginning Byte N
O			O
O			O
O			O
ACK			Byte N + X - 1
N	Not acknowledge		
P	stoP bit		

SMBus Table: Frequency Select Register, READ/WRITE ADDRESS (Selectable)

Byte 0	Pin #	Name	Control Function	Type	0	1	Default
Bit 7	-	PD_Mode	PD# drive mode	RW	driven	Hi-Z	1
Bit 6	-	OE_Mode	OE#_Stop drive mode	RW	driven	Hi-Z	0
Bit 5	-	Reserved					0
Bit 4	-	Reserved					X
Bit 3	-	MODE1	BYPASS#/PLL1	RW	See Operating Mode Readback Table		Input
Bit 2	-	Reserved					1
Bit 1	-	MODE0	BYPASS#/PLL0	RW	See Operating Mode Readback Table		Input
Bit 0	-	SRC_DIV#	SRC Divide by 2 Select	RW	x/2	x/1	1

SMBus Table: Output Control Register

Byte 1	Pin #	Name	Control Function	Type	0	1	Default
Bit 7		Reserved					1
Bit 6	22,23	DIF_6	Output Enable	RW	Disable	Enable	1
Bit 5	19,20	DIF_5	Output Enable	RW	Disable	Enable	1
Bit 4		Reserved					1
Bit 3		Reserved					1
Bit 2	9,10	DIF_2	Output Enable	RW	Disable	Enable	1
Bit 1	6,7	DIF_1	Output Enable	RW	Disable	Enable	1
Bit 0		Reserved					1

NOTE: The SMBus Output Enable Bit must be '1' AND the respective OE pin must be active for the output to run!

SMBus Table: OE Pin Control Register

Byte 2	Pin #	Name	Control Function	Type	0	1	Default
Bit 7		Reserved					0
Bit 6	22,23	DIF_6	DIF_6 Stoppable with DIFSTOP	RW	Free-run	Stoppable	0
Bit 5	19,20	DIF_5	DIF_5 Stoppable with DIFSTOP	RW	Free-run	Stoppable	0
Bit 4		Reserved					0
Bit 3		Reserved					0
Bit 2	9,10	DIF_2	DIF_2 Stoppable with DIFSTOP	RW	Free-run	Stoppable	0
Bit 1	6,7	DIF_1	DIF_1 Stoppable with DIFSTOP	RW	Free-run	Stoppable	0
Bit 0		Reserved					0

SMBus Table: Reserved Register

Byte 3	Pin #	Name	Control Function	Type	0	1	Default
Bit 7		Reserved					X
Bit 6		Reserved					X
Bit 5		Reserved					X
Bit 4		Reserved					X
Bit 3		Reserved					X
Bit 2		Reserved					X
Bit 1		Reserved					X
Bit 0		Reserved					X

SMBus Table: Vendor & Revision ID Register

Byte 4	Pin #	Name	Control Function	Type	0	1	Default
Bit 7	-	RID3	REVISION ID	R	-	-	0
Bit 6	-	RID2		R	-	-	0
Bit 5	-	RID1		R	-	-	0
Bit 4	-	RID0		R	-	-	0
Bit 3	-	VID3	VENDOR ID	R	-	-	0
Bit 2	-	VID2		R	-	-	0
Bit 1	-	VID1		R	-	-	0
Bit 0	-	VID0		R	-	-	1

SMBus Table: DEVICE ID

Byte 5	Pin #	Name	Control Function	Type	0	1	Default
Bit 7	-	Device ID 7 (MSB)		R	Device ID is 43 Hex for 9DB433		0
Bit 6	-	Device ID 6		R			1
Bit 5	-	Device ID 5		R			0
Bit 4	-	Device ID 4		R			0
Bit 3	-	Device ID 3		R			0
Bit 2	-	Device ID 2		R			0
Bit 1	-	Device ID 1		R			1
Bit 0	-	Device ID 0		R			1

SMBus Table: Byte Count Register

Byte 6	Pin #	Name	Control Function	Type	0	1	Default
Bit 7	-	BC7	Writing to this register configures how many bytes will be read back.	RW	-	-	0
Bit 6	-	BC6		RW	-	-	0
Bit 5	-	BC5		RW	-	-	0
Bit 4	-	BC4		RW	-	-	0
Bit 3	-	BC3		RW	-	-	0
Bit 2	-	BC2		RW	-	-	1
Bit 1	-	BC1		RW	-	-	1
Bit 0	-	BC0		RW	-	-	1

PD#, Power Down

The PD# pin cleanly shuts off all clocks and places the device into a power saving mode. PD# must be asserted before shutting off the input clock or power to insure an orderly shutdown. PD is asynchronous active-low input for both powering down the device and powering up the device. When PD# is asserted, all clocks will be driven high, or tri-stated (depending on the PD# drive mode and Output control bits) before the PLL is shut down.

PD# Assertion

When PD# is sampled low by two consecutive rising edges of DIF#, all DIF outputs must be held High, or tri-stated (depending on the PD# drive mode and Output control bits) on the next High-Low transition of the DIF# outputs. When the PD# drive mode bit is set to '0', all clock outputs will be held with DIF driven High with 2 x IREF and DIF# tri-stated. If the PD# drive mode bit is set to '1', both DIF and DIF# are tri-stated.

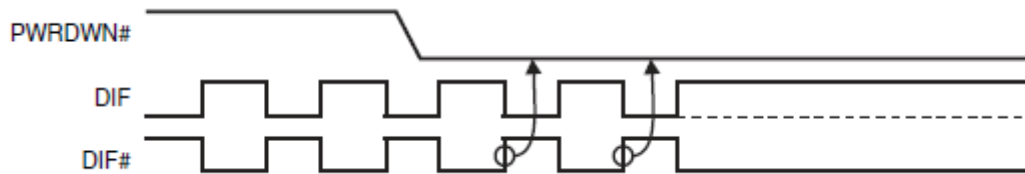

PD# De-assertion

Power-up latency is less than 1 ms. This is the time from de-assertion of the PD# pin, or VDD reaching 3.3V, or the time from valid SRC_IN clocks until the time that stable clocks are output from the device (PLL Locked). If the PD# drive mode bit is set to '1', all the DIF outputs must be driven to a voltage of >200 mV within 300 us of PD# de-assertion.

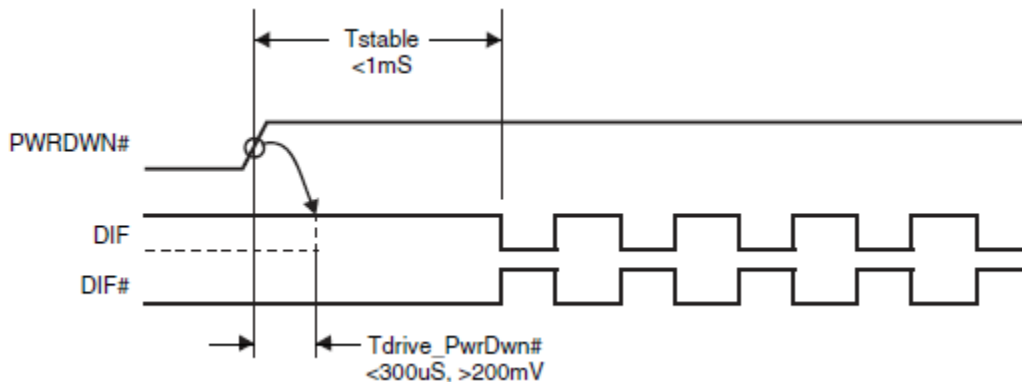

Package Outline and Package Dimensions (28-pin SSOP)

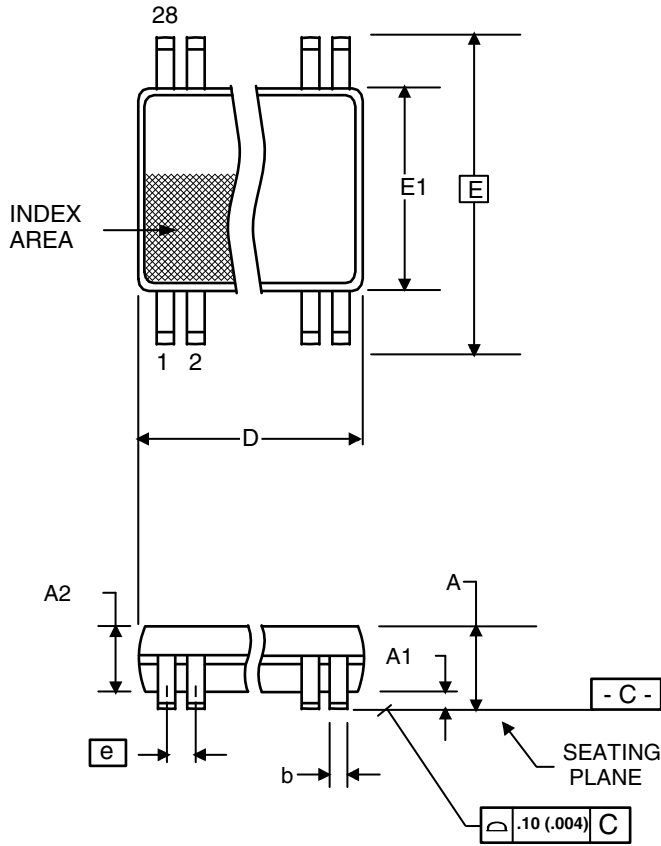

209 mil SSOP

SYMBOL	In Millimeters		In Inches	
	COMMON DIMENSIONS		COMMON DIMENSIONS	
A	--	2.00	--	.079
A1	0.05	--	.002	--
A2	1.65	1.85	.065	.073
b	0.22	0.38	.009	.015
c	0.09	0.25	.0035	.010
D	SEE VARIATIONS		SEE VARIATIONS	
E	7.40	8.20	.291	.323
E1	5.00	5.60	.197	.220
e	0.65 BASIC		0.0256 BASIC	
L	0.55	0.95	.022	.037
N	SEE VARIATIONS		SEE VARIATIONS	
α	0°	8°	0°	8°

VARIATIONS

N	D mm.		D (inch)	
	MIN	MAX	MIN	MAX
28	9.90	10.50	.390	.413

Reference Doc.: JEDEC Publication 95, MO-150

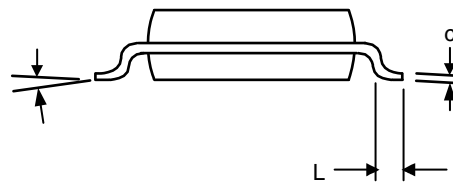

Package Outline and Package Dimensions (28-pin TSSOP)

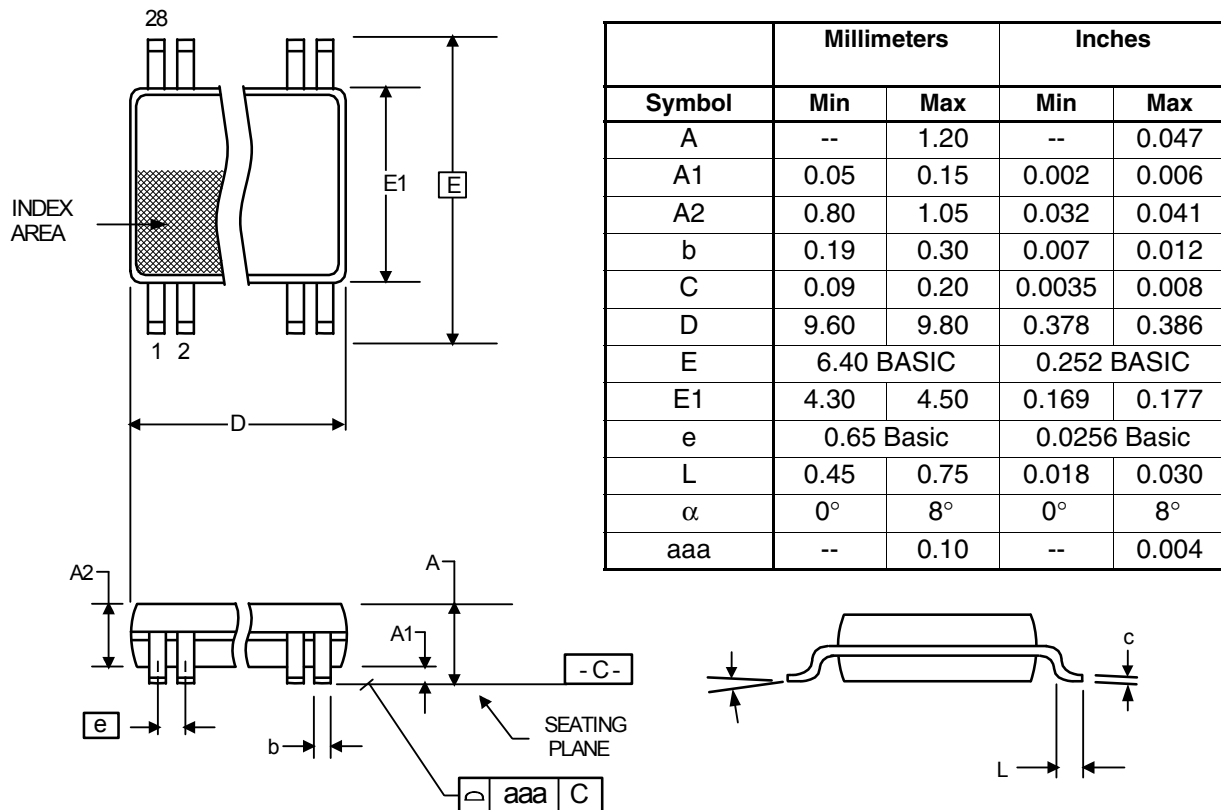

Ordering Information

Part / Order Number	Shipping Packaging	Package	Temperature
9DB433AFLF	Tubes	28-pin SSOP	0 to +70°C
9DB433AFLFT	Tape and Reel	28-pin SSOP	0 to +70°C
9DB433AGLF	Tubes	28-pin TSSOP	0 to +70°C
9DB433AGLFT	Tape and Reel	28-pin TSSOP	0 to +70°C
9DB433AFILF	Tubes	28-pin SSOP	-40 to +85°C
9DB433AFLIFT	Tape and Reel	28-pin SSOP	-40 to +85°C
9DB433AGILF	Tubes	28-pin TSSOP	-40 to +85°C
9DB433AGILFT	Tape and Reel	28-pin TSSOP	-40 to +85°C

"LF" suffix to the part number denotes Pb-Free configuration, RoHS compliant.

"A" is the device revision designator (will not correlate with the datasheet revision).

While the information presented herein has been checked for both accuracy and reliability, Integrated Device Technology (IDT) assumes no responsibility for either its use or for the infringement of any patents or other rights of third parties, which would result from its use. No other circuits, patents, or licenses are implied. This product is intended for use in normal commercial applications. Any other applications such as those requiring extended temperature range, high reliability, or other extraordinary environmental requirements are not recommended without additional processing by IDT. IDT reserves the right to change any circuitry or specifications without notice. IDT does not authorize or warrant any IDT product for use in life support devices or critical medical instruments.

Revision History

Rev.	Issue Date	Who	Description	Page #
A	6/30/2010	RDW	Released to final	
B	5/9/2011	RDW	1. Update pin 1 pin-name and pin description from VDD to VDDR. This highlights that optimal performance is obtained by treating VDDR as in analog pin. This is a document update only, there is no silicon change.	Various
C	3/13/2012	RDW	1. Added additional line to PLL Bandwidth "-3dB point in High BW Mode" conditions for industrial mode (min1.5, typ 2.7, max 4.1 MHz) 2. Added additional line to Skew, Input to Output "Bypass Mode" conditions for industrial mode (min 2500, max 4900 ps)	6
D	7/5/2012	RDW	1. Changed references of PCIe Gen3 to PCIe Gen1,2,3	1
E	7/12/2012	RDW	1. Added missing typical values to DS.	Various
F	9/18/2012	RDW	Updated Byte 2, bits 1, 2, 5 and 6 per char review. Outputs can be programmed with Byte 2 to be Stoppable or Free-Run with DIF_Stop pin, not the OE pins.	Various

Innovate with IDT and accelerate your future networks. Contact:

www.IDT.com

For Sales

800-345-7015
408-284-8200
Fax: 408-284-2775

For Tech Support

www.idt.com/go/clockhelp
pcclockhelp@idt.com

Corporate Headquarters

Integrated Device Technology, Inc.
www.idt.com

