

Programmable Timing Control Hub™ for Intel Systems ICS9E4101

Recommended Application:

I-temp CK410 clock, Intel Yellow Cover part

Output Features:

- 2 - 0.7V current-mode differential CPU pairs
- 6 - 0.7V current-mode differential SRC pair for SATA and PCI-E
- 1 - 0.7V current-mode differential CPU/SRC selectable pair
- 6 - PCI (33MHz)
- 3 - PCICLK_F, (33MHz) free-running
- 1 - USB, 48MHz
- 1 - DOT, 96MHz, 0.7V current differential pair
- 1 - REF, 14.318MHz

Key Specifications:

- CPU outputs cycle-cycle jitter < 85ps
- SRC output cycle-cycle jitter < 125ps
- PCI outputs cycle-cycle jitter < 500ps
- +/- 300ppm frequency accuracy on CPU & SRC clocks

Functionality

FS_C ¹	FS_B ²	FS_A ²	CPU MHz	SRC MHz	PCI MHz	REF MHz	USB MHz	DOT MHz	
0	0	0	266.66	100.00	33.33	14.318	48.00	96.00	
0	0	1	133.33	100.00	33.33	14.318	48.00	96.00	
0	1	0	200.00	100.00	33.33	14.318	48.00	96.00	
0	1	1	RESERVED						
1	0	0	RESERVED						
1	0	1	100.00	100.00	33.33	14.318	48.00	96.00	
1	1	0	RESERVED						
1	1	1	RESERVED						

1. FS_C is a three-level input. Please see V_{IL,FS} and V_{IH,FS} specifications in the Input/Supply/Common Output Parameters Table for correct values. Also refer to the Test Clarification Table.
 2. FS_B and FS_A are low-threshold inputs. Please see the V_{IL,FS} and V_{IH,FS} specifications in the Input/Supply/Common Output Parameters Table for correct values.

Features/Benefits:

- Supports tight ppm accuracy clocks for Serial-ATA and PCI-Express
- Supports spread spectrum modulation, 0 to -0.5% down spread
- Supports CPU clks up to 400MHz
- Uses external 14.318MHz crystal, external crystal load caps are required for frequency tuning
- Supports undriven differential CPU, SRC pair in PD# for power management.

Pin Configuration

VDDPCI	1	56	PCICLK2
GND	2	55	PCICLK1
PCICLK3	3	54	PCICLK0
PCICLK4	4	53	FS_C/TEST_SEL
PCICLK5	5	52	REFOUT
GND	6	51	GND
VDDPCI	7	50	X1
ITP_EN/PCICLK_F0	8	49	X2
PCICLK_F1	9	48	VDDREF
PCICLK_F2	10	47	SDATA
VDD48	11	46	SCLK
USB_48MHz	12	45	GND
GND	13	44	CPUCLKT0
DOTT_96MHz	14	43	CPUCLKC0
DOTC_96MHz	15	42	VDDCPU
FS_B/TEST_MODE	16	41	CPUCLKT1
Vtt_PwrGd#/PD	17	40	CPUCLKC1
FS_A_410	18	39	IREF
SRCCCLKT1	19	38	GND
SRCCCLKC1	20	37	VDDA
VDDSRC	21	36	CPUCLKT2_ITP/SRCCCLKT_7
SRCCCLKT2	22	35	CPUCLKC2_ITP/SRCCCLKC_7
SRCCCLKC2	23	34	VDDSRC
SRCCCLKT3	24	33	SRCCCLKT6
SRCCCLKC3	25	32	SRCCCLKC6
SRCCCLKT4_SATA	26	31	SRCCCLKT5
SRCCCLKC4_SATA	27	30	SRCCCLKC5
VDDSRC	28	29	GND

56-pin SSOP

Pin Description

Pin #	PIN NAME	PIN TYPE	DESCRIPTION
1	VDDPCI	PWR	Power supply for PCI clocks, nominal 3.3V
2	GND	PWR	Ground pin.
3	PCICLK3	OUT	PCI clock output.
4	PCICLK4	OUT	PCI clock output.
5	PCICLK5	OUT	PCI clock output.
6	GND	PWR	Ground pin.
7	VDDPCI	PWR	Power supply for PCI clocks, nominal 3.3V
8	ITP_EN/PCICLK_F0	I/O	Free running PCI clock not affected by PCI_STOP#. ITP_EN: latched input to select pin functionality 1 = CPU_ITP pair 0 = SRC pair
9	PCICLK_F1	OUT	Free running PCI clock not affected by PCI_STOP# .
10	PCICLK_F2	OUT	Free running PCI clock not affected by PCI_STOP# .
11	VDD48	PWR	Power pin for the 48MHz output.3.3V
12	USB_48MHz	OUT	48.00MHz USB clock
13	GND	PWR	Ground pin.
14	DOTT_96MHz	OUT	True clock of differential pair for 96.00MHz DOT clock.
15	DOTC_96MHz	OUT	Complement clock of differential pair for 96.00MHz DOT clock.
16	FS_B/TEST_MODE	IN	3.3V tolerant input for CPU frequency selection. Refer to input electrical characteristics for Vil_FS and Vih_FS values. TEST_MODE is a real time input to select between Hi-Z and REF/N divider mode while in test mode. Refer to Test Clarification Table.
17	Vtt_PwrGd#/PD	IN	Vtt_PwrGd# is an active low input used to determine when latched inputs are ready to be sampled. PD is an asynchronous active high input pin used to put the device into a low power state. The internal clocks, PLLs and the crystal oscillator are stopped.
18	FS_A_410	IN	3.3V tolerant low threshold input for CPU frequency selection. This pin requires CK410 FSA. Refer to input electrical characteristics for Vil_FS and Vih_FS threshold values.
19	SRCCLKT1	OUT	True clock of differential SRC clock pair.
20	SRCCLKC1	OUT	Complement clock of differential SRC clock pair.
21	VDDSRC	PWR	Supply for SRC clocks, 3.3V nominal
22	SRCCLKT2	OUT	True clock of differential SRC clock pair.
23	SRCCLKC2	OUT	Complement clock of differential SRC clock pair.
24	SRCCLKT3	OUT	True clock of differential SRC clock pair.
25	SRCCLKC3	OUT	Complement clock of differential SRC clock pair.
26	SRCCLKT4_SATA	OUT	True clock of differential SRC/SATA pair.
27	SRCCLKC4_SATA	OUT	Complement clock of differential SRC/SATA pair.
28	VDDSRC	PWR	Supply for SRC clocks, 3.3V nominal

Pin Description (continued)

Pin #	PIN NAME	TYPE	DESCRIPTION
29	GND	PWR	Ground pin.
30	SRCCLKC5	OUT	Complement clock of differential SRC clock pair.
31	SRCCLKT5	OUT	True clock of differential SRC clock pair.
32	SRCCLKC6	OUT	Complement clock of differential SRC clock pair.
33	SRCCLKT6	OUT	True clock of differential SRC clock pair.
34	VDDSRC	PWR	Supply for SRC clocks, 3.3V nominal
35	CPUCLKC2_ITP/SRCCLKC_7	OUT	Complimentary clock of CPU_ITP/SRC differential pair CPU_ITP/SRC output. These are current mode outputs. External resistors are required for voltage bias. Selected by ITP_EN input.
36	CPUCLKT2_ITP/SRCCLKT_7	OUT	True clock of CPU_ITP/SRC differential pair CPU_ITP/SRC output. These are current mode outputs. External resistors are required for voltage bias. Selected by ITP_EN input.
37	VDDA	PWR	3.3V power for the PLL core.
38	GND A	PWR	Ground pin for the PLL core.
39	IREF	OUT	This pin establishes the reference current for the differential current-mode output pairs. This pin requires a fixed precision resistor tied to ground in order to establish the appropriate current. 475 ohms is the standard value.
40	CPUCLKC1	OUT	Complimentary clock of differential pair CPU outputs. These are current mode outputs. External resistors are required for voltage bias.
41	CPUCLKT1	OUT	True clock of differential pair CPU outputs. These are current mode outputs. External resistors are required for voltage bias.
42	VDDCPU	PWR	Supply for CPU clocks, 3.3V nominal
43	CPUCLKC0	OUT	Complimentary clock of differential pair CPU outputs. These are current mode outputs. External resistors are required for voltage bias.
44	CPUCLKT0	OUT	True clock of differential pair CPU outputs. These are current mode outputs. External resistors are required for voltage bias.
45	GND	PWR	Ground pin.
46	SCLK	IN	Clock pin of SMBus circuitry, 5V tolerant.
47	SDATA	I/O	Data pin for SMBus circuitry, 5V tolerant.
48	VDDREF	PWR	Ref, XTAL power supply, nominal 3.3V
49	X2	OUT	Crystal output, Nominally 14.318MHz
50	X1	IN	Crystal input, Nominally 14.318MHz.
51	GND	PWR	Ground pin.
52	REFOUT	OUT	Reference Clock output
53	FS_C/TEST_SEL	IN	3.3V tolerant input for CPU frequency selection. Low voltage threshold inputs, see input electrical characteristics for Vil_FS and Vih_FS values. TEST_Sel: 3-level latched input to enable test mode. Refer to Test Clarification Table
54	PCICLK0	OUT	PCI clock output.
55	PCICLK1	OUT	PCI clock output.
56	PCICLK2	OUT	PCI clock output.

General Description

ICS9E4101 follows Intel CK410 Yellow Cover specification. This clock synthesizer provides a single chip solution for next generation P4 Intel processors and Intel chipsets. **ICS9E4101** is driven with a 14.318MHz crystal. It generates CPU outputs up to 400MHz. It also provides a tight ppm accuracy output for Serial ATA and PCI-Express support.

Block Diagram

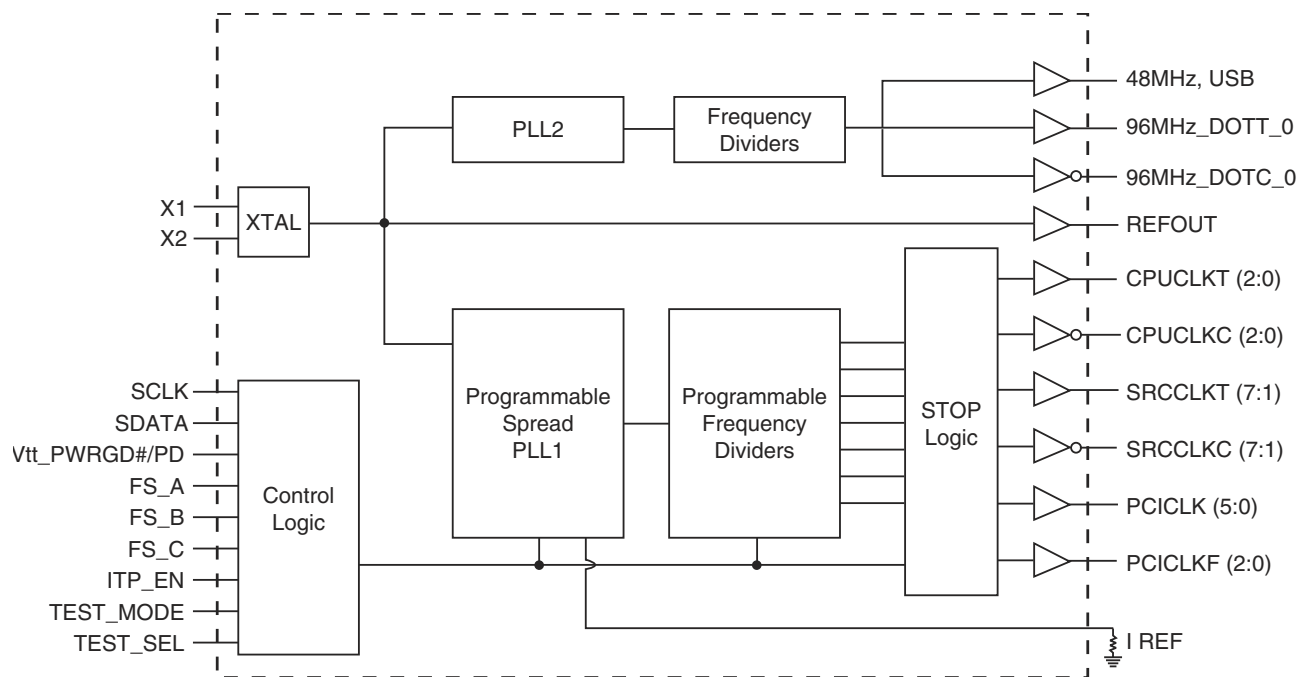

Power Groups

Pin Number		Description
VDD	GND	
48	51	Xtal, Ref
1,7	2,6	PCICLK outputs
21,28,34	29	SRCCLK outputs
37	38	Master clock, CPU Analog
11	13	DOT, USB, PLL_48
42	45	CPUCLK clocks

General I²C serial interface information for the ICS9E4101

How to Write:

- Controller (host) sends a start bit.
- Controller (host) sends the write address D2_(H)
- ICS clock will **acknowledge**
- Controller (host) sends the beginning byte location = N
- ICS clock will **acknowledge**
- Controller (host) sends the data byte count = X
- ICS clock will **acknowledge**
- Controller (host) starts sending **Byte N through Byte N + X - 1**
 (see Note 2)
- ICS clock will **acknowledge** each byte **one at a time**
- Controller (host) sends a Stop bit

How to Read:

- Controller (host) will send start bit.
- Controller (host) sends the write address D2_(H)
- ICS clock will **acknowledge**
- Controller (host) sends the beginning byte location = N
- ICS clock will **acknowledge**
- Controller (host) will send a separate start bit.
- Controller (host) sends the read address D3_(H)
- ICS clock will **acknowledge**
- ICS clock will send the data byte count = X
- ICS clock sends **Byte N + X - 1**
- ICS clock sends **Byte 0 through byte X (if X_(H) was written to byte 8).**
- Controller (host) will need to acknowledge each byte
- Controller (host) will send a not acknowledge bit
- Controller (host) will send a stop bit

Index Block Write Operation		
Controller (Host)		ICS (Slave/Receiver)
T	starT bit	
Slave Address D2 _(H)		
WR	WRite	
		ACK
Beginning Byte = N		
		ACK
Data Byte Count = X		
		ACK
Beginning Byte N		X Byte
○		
○		
○		
Byte N + X - 1		
		ACK
P	stoP bit	

Index Block Read Operation		
Controller (Host)		ICS (Slave/Receiver)
T	starT bit	
Slave Address D2 _(H)		
WR	WRite	
		ACK
Beginning Byte = N		
		ACK
RT	Repeat starT	
Slave Address D3 _(H)		
RD	ReaD	
		ACK
		Data Byte Count = X
ACK		X Byte
ACK		
○		
○		
○		
		Byte N + X - 1
N	Not acknowledge	
P	stoP bit	

I²C Table: Read-Back Register

Byte 0	Pin #	Name	Control Function	Type	0	1	PWD
Bit 7	35,36	CPUCLK2/RCCLK7 Enable	Output Enable	RW	DISABLE	ENABLE	1
Bit 6	32,33	SRCCLK6 Enable	Output Enable	RW	DISABLE	ENABLE	1
Bit 5	30,31	SRCCLK5 Enable	Output Enable	RW	DISABLE	ENABLE	1
Bit 4	26,27	SRCCLK4 Enable	Output Enable	RW	DISABLE	ENABLE	1
Bit 3	24,25	SRCCLK3 Enable	Output Enable	RW	DISABLE	ENABLE	1
Bit 2	22,23	SRCCLK2 Enable	Output Enable	RW	DISABLE	ENABLE	1
Bit 1	19,20	SRCCLK1 Enable	Output Enable	RW	DISABLE	ENABLE	1
Bit 0	-	RESERVED					

I²C Table: Spreading and Device Behavior Control Register

Byte 1	Pin #	Name	Control Function	Type	0	1	PWD
Bit 7	54	PCI_F0 Enable	Output Enable	RW	Disable	Enable	1
Bit 6	14,15	DOT_96MHz	Output Enable	RW	Disable	Enable	1
Bit 5	12	USB_48MHz Enable	Output Enable	RW	Disable	Enable	1
Bit 4	52	REFOUT Enable	Output Enable	RW	Disable	Enable	1
Bit 3		RESERVED					
Bit 2	40,41	CPUT1/CPUC1	Output Enable	RW	Disable	Enable	1
Bit 1	43,44	CPUT0/CPUC0	Output Enable	RW	Disable	Enable	1
Bit 0	-	Spread Spectrum Mode	Spread Off	RW	SPREAD OFF	SPREAD ON	0

I²C Table: Output Control Register

Byte 2	Pin #	Name	Control Function	Type	0	1	PWD
Bit 7	5	PCICLK5	Output Enable	RW	Disable	Enable	1
Bit 6	4	PCICLK4	Output Enable	RW	Disable	Enable	1
Bit 5	3	PCICLK3	Output Enable	RW	Disable	Enable	1
Bit 4	56	PCICLK2	Output Enable	RW	Disable	Enable	1
Bit 3	55	PCICLK1	Output Enable	RW	Disable	Enable	1
Bit 2	54	PCICLK0	Output Enable	RW	Disable	Enable	1
Bit 1	10	PCI_F2 Enable	Output Enable	RW	Disable	Enable	1
Bit 0	9	PCI_F1 Enable	Output Enable	RW	Disable	Enable	1

I²C Table: Output Control Register

Byte 3	Pin #	Name	Control Function	Type	0	1	PWD
Bit 7	35,35	CPU_ITP/SRCCLK7	Free-Running Control default: not affected by PCI/SRC_STOP (Byte 6, bit 3)	RW	Free-Running	Stoppable	0
Bit 6	32,33	SRCCLK6		RW	Free-Running	Stoppable	0
Bit 5	30,31	SRCCLK5		RW	Free-Running	Stoppable	0
Bit 4	26,27	SRCCLK4		RW	Free-Running	Stoppable	0
Bit 3	24,25	SRCCLK3		RW	Free-Running	Stoppable	0
Bit 2	22,23	SRCCLK2		RW	Free-Running	Stoppable	0
Bit 1	19,20	SRCCLK1		RW	Free-Running	Stoppable	0
Bit 0	-	RESERVED					

I²C Table: Output Control Register

Byte 4	Pin #	Name	Control Function	Type	0	1	PWD
Bit 7		RESERVED					
Bit 6	14,15	DOT_96MHz	Driven in PD	RW	Driven	Hi-Z	1
Bit 5	10	PCI_F2	Free-Running Control not affected by	RW	Free-Running	Stoppable	1
Bit 4	9	PCI_F1		RW	Free-Running	Stoppable	1
Bit 3	8	PCI_F0		RW	Free-Running	Stoppable	1
Bit 2		RESERVED					
Bit 1		RESERVED					
Bit 0		RESERVED					

I²C Table: Output Control Register

Byte 5	Pin #	Name	Control Function	Type	0	1	PWD
Bit 7	19,20,22,23, 24,25,26,27,30,31, 32,33,35,36	SRC Stop Drive Mode	Drive Mode in PCI_Stop	RW	Driven	Hi-Z	0
Bit 6		RESERVED					0
Bit 5		RESERVED					0
Bit 4		RESERVED					0
Bit 3	19,20,22,23, 24,25,26,27,30,31, 32,33,35,36	SRC PD Drive Mode	Drive Mode in PD	RW	Driven	Hi-Z	0
Bit 2	35,36	CPUCLK_ITP	Drive Mode in PD	RW	Driven	Hi-Z	0
Bit 1	40,41	CPUCLK1	Drive mode in PD	RW	Driven	Hi-Z	0
Bit 0	43,44	CPUCLK0	Drive mode in PD	RW	Driven	Hi-Z	0

I²C Table: Output Control Register

Byte 6	Pin #	Name	Control Function	Type	0	1	PWD
Bit 7	-	Test Mode Selection	Test Mode Selection	RW	Hi-Z	REF/N	0
Bit 6	-	Test Clock Mode Entry	Test Mode	RW	Disable	Enable	0
Bit 5	-	RESERVED					0
Bit 4	52	REFOUT Strength	Strength Prog	RW	1X	2X	1
Bit 3	17,18,19,20,22,23, 24,25,26,27,30,31, 32,33,35,36 54,55,56,3,4,5,8,9, 10	PCI/SRC_STOP	Stop all PCI and SRC clocks	RW	Enabled, all stoppable PCI and SRC clocks are stopped.	Disabled, all stoppable PCI and SRC clocks are running	1
Bit 2	-	FS_C	readback	R	-	-	LATCHED
Bit 1	-	FS_B	readback	R	-	-	LATCHED
Bit 0	-	FS_A	readback	R	-	-	LATCHED

I²C Table: Vendor & Revision ID Register

Byte 7	Pin #	Name	Control Function	Type	0	1	PWD
Bit 7	-	RID3	REVISION ID	R	-	-	0
Bit 6	-	RID2		R	-	-	0
Bit 5	-	RID1		R	-	-	0
Bit 4	-	RID0		R	-	-	0
Bit 3	-	VID3	VENDOR ID	R	-	-	0
Bit 2	-	VID2		R	-	-	0
Bit 1	-	VID1		R	-	-	0
Bit 0	-	VID0		R	-	-	1

I²C Table: Byte Count Register

Byte 8	Pin #	Name	Control Function	Type	0	1	PWD
Bit 7	-	BC7	Writing to this register will configure how many bytes will be read back, default is 08 = 8 bytes.	RW	-	-	0
Bit 6	-	BC6		RW	-	-	0
Bit 5	-	BC5		RW	-	-	0
Bit 4	-	BC4		RW	-	-	0
Bit 3	-	BC3		RW	-	-	1
Bit 2	-	BC2		RW	-	-	0
Bit 1	-	BC1		RW	-	-	0
Bit 0	-	BC0		RW	-	-	0

I²C Table: Watchdog Timer Register

Byte 9	Pin #	Name	Control Function	Type	0	1	PWD
Bit 7			RESERVED				0
Bit 6			RESERVED				0
Bit 5			RESERVED				0
Bit 4	-	WD4	Enables programming bytes 10-19	RW	-	-	0
Bit 3	-	WD3		RW	-	-	0
Bit 2	-	WD2		RW	-	-	0
Bit 1	-	WD1		RW	-	-	0
Bit 0	-	WD0		RW	-	-	0

I²C Table: VCO Control Select Bit & WD Timer Control Register

Byte 10	Pin #	Name	Control Function	Type	0	1	PWD
Bit 7	-	M/NEN	M/N Programming Enable	RW	Disable	Enable	0
Bit 6	-	WDEN	Watchdog Enable	R	Disable	Enable	1
Bit 5			RESERVED				0
Bit 4			RESERVED				0
Bit 3			RESERVED				0
Bit 2			RESERVED				0
Bit 1			RESERVED				0
Bit 0			RESERVED				0

I²C Table: VCO Frequency Control Register

Byte 11	Pin #	Name	Control Function	Type	0	1	PWD
Bit 7	-	N Div8	N Divider Bit 8	RW	-	-	X
Bit 6	-	M Div6	The decimal representation of M Div (6:0) is equal to reference divider value. Default at power up = latch-in or Byte 0 Rom	RW	-	-	X
Bit 5	-	M Div5		RW	-	-	X
Bit 4	-	M Div4		RW	-	-	X
Bit 3	-	M Div3		RW	-	-	X
Bit 2	-	M Div2		RW	-	-	X
Bit 1	-	M Div1		RW	-	-	X
Bit 0	-	M Div0		RW	-	-	X

I²C Table: VCO Frequency Control Register

Byte 12	Pin #	Name	Control Function	Type	0	1	PWD
Bit 7	-	N Div7	The decimal representation of N Div (8:0) is equal to VCO divider value. Default at power up = latch-in or Byte 0 Rom table.	RW	-	-	X
Bit 6	-	N Div6		RW	-	-	X
Bit 5	-	N Div5		RW	-	-	X
Bit 4	-	N Div4		RW	-	-	X
Bit 3	-	N Div3		RW	-	-	X
Bit 2	-	N Div2		RW	-	-	X
Bit 1	-	N Div1		RW	-	-	X
Bit 0	-	N Div0		RW	-	-	X

I²C Table: Spread Spectrum Control Register

Byte 13	Pin #	Name	Control Function	Type	0	1	PWD
Bit 7	-	SSP7	These Spread Spectrum bits will program the spread percentage. It is recommended to use ICS Spread % table for spread programming.	RW	-	-	X
Bit 6	-	SSP6		RW	-	-	X
Bit 5	-	SSP5		RW	-	-	X
Bit 4	-	SSP4		RW	-	-	X
Bit 3	-	SSP3		RW	-	-	X
Bit 2	-	SSP2		RW	-	-	X
Bit 1	-	SSP1		RW	-	-	X
Bit 0	-	SSP0		RW	-	-	X

I²C Table: Spread Spectrum Control Register

Byte 14	Pin #	Name	Control Function	Type	0	1	PWD
Bit 7			RESERVED				0
Bit 6			RESERVED				0
Bit 5	-	SSP13	It is recommended to use ICS Spread % table for spread programming.	RW	-	-	X
Bit 4	-	SSP12		RW	-	-	X
Bit 3	-	SSP11		RW	-	-	X
Bit 2	-	SSP10		RW	-	-	X
Bit 1	-	SSP9		RW	-	-	X
Bit 0	-	SSP8	RW	-	-	X	

I²C Table: Output Divider Control Register

Byte 15	Pin #	Name	Control Function	Type	0	1	PWD
Bit 7	-	SRC Div3	SRC divider ratio can be configured via these 4 bits individually.	RW	See Table: Divider Ratio Combination Table		X
Bit 6	-	SRC Div2		RW			X
Bit 5	-	SRC Div1		RW			X
Bit 4	-	SRC Div0		RW			X
Bit 3	-	CPU Div3	CPU divider ratio can be configured via these 4 bits individually.	RW	See Table: Divider Ratio Combination Table		X
Bit 2	-	CPU Div2		RW			X
Bit 1	-	CPU Div1		RW			X
Bit 0	-	CPU Div0		RW			X

I²C Table: Output Divider Control Register

Byte 16	Pin #	Name	Control Function	Type	0	1	PWD
Bit 7			RESERVED				0
Bit 6			RESERVED				0
Bit 5			RESERVED				0
Bit 4			RESERVED				0
Bit 3	-	PCI Div3	PCI divider ratio can be configured via these 4 bits individually.	RW	See Table: Divider Ratio Combination Table		X
Bit 2	-	PCI Div2		RW			X
Bit 1	-	PCI Div1		RW			X
Bit 0	-	PCI Div0		RW			X

I²C Table: Vendor & Revision ID Register

Byte 17	Pin #	Name	Control Function	Type	0	1	PWD
Bit 7			RESERVED				0
Bit 6	-	PCIINV	PCI Phase Invert	RW	Default	Inverse	0
Bit 5	-	SRCINV	SRC Phase Invert	RW	Default	Inverse	0
Bit 4	-	CPUINV	CPU Phase Invert	RW	Default	Inverse	0
Bit 3			RESERVED				0
Bit 2			RESERVED				0
Bit 1			RESERVED				0
Bit 0			RESERVED				0

I²C Table: Group Skew Control Register

Byte 18	Pin #	Name	Control Function	Type	0	1	PWD
Bit 7	-	SRC_Skw3	SRC Skew Control	RW	See Table: 7-Steps Skew Programming Table		0
Bit 6	-	SRC_Skw2		RW			0
Bit 5	-	SRC_Skw1		RW			0
Bit 4	-	SRC_Skw0		RW			0
Bit 3	-	CPU_Skw3	CPU Skew Control	RW	See Table: 7-Steps Skew Programming Table		0
Bit 2	-	CPU_Skw2		RW			0
Bit 1	-	CPU_Skw1		RW			0
Bit 0	-	CPU_Skw0		RW			0

I²C Table: Group Skew Control Register

Byte 19	Pin #	Name	Control Function	Type	0	1	PWD
Bit 7			RESERVED				0
Bit 6			RESERVED				0
Bit 5			RESERVED				0
Bit 4			RESERVED				0
Bit 3	-	PCI_Skw3	PCI Skew Control	RW	See Table: 7-Steps Skew Programming Table		0
Bit 2	-	PCI_Skw2		RW		0	
Bit 1	-	PCI_Skw1		RW		0	
Bit 0	-	PCI_Skw0		RW		0	

I²C Table: Slew Rate Control Register

Byte 20	Pin #	Name	Control Function	Type	0	1	PWD
Bit 7			RESERVED				0
Bit 6			RESERVED				0
Bit 5			RESERVED				0
Bit 4			RESERVED				0
Bit 3			RESERVED				0
Bit 2			RESERVED				0
Bit 1			RESERVED				0
Bit 0			RESERVED				0

I²C Table: Slew Rate Control Register

Byte 21	Pin #	Name	Control Function	Type	0	1	PWD
Bit 7			RESERVED				0
Bit 6			RESERVED				0
Bit 5			RESERVED				0
Bit 4			RESERVED				0
Bit 3			RESERVED				0
Bit 2			RESERVED				0
Bit 1			RESERVED				0
Bit 0			RESERVED				0

I²C Table: Slew Rate Control Register

Byte 22	Pin #	Name	Control Function	Type	0	1	PWD
Bit 7			RESERVED				0
Bit 6			RESERVED				0
Bit 5			RESERVED				0
Bit 4			RESERVED				0
Bit 3			RESERVED				0
Bit 2			RESERVED				0
Bit 1			RESERVED				0
Bit 0			RESERVED				0

I²C Table: Slew Rate Control Register

Byte 23	Pin #	Name	Control Function	Type	0	1	PWD
Bit 7			RESERVED				0
Bit 6			RESERVED				0
Bit 5			RESERVED				0
Bit 4			RESERVED				0
Bit 3			RESERVED				0
Bit 2			RESERVED				0
Bit 1			RESERVED				0
Bit 0			RESERVED				0

I²C Table: Slew Rate Control Register

Byte 24	Pin #	Name	Control Function	Type	0	1	PWD
Bit 7			RESERVED				0
Bit 6			RESERVED				0
Bit 5			RESERVED				0
Bit 4			RESERVED				0
Bit 3			RESERVED				0
Bit 2			RESERVED				0
Bit 1			RESERVED				0
Bit 0			RESERVED				0

I²C Table: Test Byte Register

Byte 25	Test	Test Function	Type	Test Result	PWD
Bit 7	-	ICS ONLY TEST	RW	Reserved	0
Bit 6	-	ICS ONLY TEST	RW	Reserved	0
Bit 5	-	ICS ONLY TEST	RW	Reserved	0
Bit 4	-	ICS ONLY TEST	RW	Reserved	0
Bit 3	-	ICS ONLY TEST	RW	Reserved	0
Bit 2	-	ICS ONLY TEST	RW	Reserved	0
Bit 1	-	ICS ONLY TEST	RW	Reserved	0
Bit 0	-	ICS ONLY TEST	RW	Reserved	0

Absolute Max

Symbol	Parameter	Min	Typ	Max	Units
VDD_A	3.3V Core Supply Voltage			V _{DD} + 0.5V	V
VDD_In	3.3V Logic Input Supply Voltage	GND - 0.5		V _{DD} + 0.5V	V
Ts	Storage Temperature	-65		150	°C
Tambient	Ambient Operating Temp	-40		85	°C
Tcase	Case Temperature			115	°C
ESD prot	Input ESD protection human body model	2000			V
Θ _{JA}	Thermal Resistance Junction to Ambient		57.4		°C/W
Θ _{JC}	Thermal Resistance Junction to Case		38.8		°C/W

Electrical Characteristics - Input/Supply/Common Output Parameters

T_A = -40 to 85°C; Supply Voltage V_{DD} = 3.3 V +/-5%

PARAMETER	SYMBOL	CONDITIONS	MIN	TYP	MAX	UNITS	NOTES
Input High Voltage	V _{IH}	3.3 V +/-5%	2		V _{DD} + 0.3	V	
Input Low Voltage	V _{IL}	3.3 V +/-5%	V _{SS} - 0.3		0.8	V	
Input High Current	I _{IH}	V _{IN} = V _{DD}	-5		5	uA	
Input Low Current	I _{IL1}	V _{IN} = 0 V; Inputs with no pull-up resistors	-5			uA	
	I _{IL2}	V _{IN} = 0 V; Inputs with pull-up resistors	-200			uA	
Low Threshold Input High Voltage	V _{IH_FS}	3.3 V +/-5%	0.7		V _{DD} + 0.3	V	
Low Threshold Input Low Voltage	V _{IL_FS}	3.3 V +/-5%	V _{SS} - 0.3		0.35	V	
Operating Supply Current	I _{DD3.30P}	3.3 V +/-5%, Full Load		350	500	mA	
Powerdown Current	I _{DD3.3PD}	all diff pairs driven			70	mA	
		all differential pairs tri-stated			12	mA	
Input Frequency ³	F _i	V _{DD} = 3.3 V		14.31818		MHz	3
Pin Inductance ¹	L _{pin}				7	nH	1
Input Capacitance ¹	C _{IN}	Logic Inputs			5	pF	1
	C _{OUT}	Output pin capacitance			6	pF	1
	C _{INX}	X1 & X2 pins			5	pF	1
Clk Stabilization ^{1,2}	T _{STAB}	From V _{DD} Power-Up or de-assertion of PD# to 1st clock			1.8	ms	1,2
Modulation Frequency		Triangular Modulation	30		33	kHz	1
Tdrive_PD#		CPU output enable after PD# de-assertion			300	us	1
Tfall_Pd#		PD# fall time of			5	ns	1
Trise_Pd#		PD# rise time of			5	ns	2
SMBus Voltage	V _{DD}		2.7		5.5	V	1
Low-level Output Voltage	V _{OL} SMBUS	@ I _{PULLUP}			0.4	V	1
Current sinking at V _{OL} = 0.4 V	I _{PULLUP}		4			mA	1
SCLK/SDATA Clock/Data Rise Time	T _{RI2C}	(Max V _{IL} - 0.15) to (Min V _{IH} + 0.15)			1000	ns	1
SCLK/SDATA Clock/Data Fall Time	T _{FI2C}	(Min V _{IH} + 0.15) to (Max V _{IL} - 0.15)			300	ns	1

¹Guaranteed by design and characterization, not 100% tested in production.

²See timing diagrams for timing requirements.

³Input frequency should be measured at the REF output pin and tuned to ideal 14.31818MHz to meet ppm accuracy on PLL outputs.

Electrical Characteristics - CPU 0.7V Current Mode Differential Pair
 $T_A = -40$ to 85°C ; $V_{DD} = 3.3\text{ V} \pm 5\%$; $C_L = 2\text{pF}$, $R_S = 33.2\Omega$, $R_P = 49.9\Omega$, $I_{REF} = 475\mu\text{A}$

PARAMETER	SYMBOL	CONDITIONS	MIN	TYP	MAX	UNITS	NOTES
Current Source Output Impedance	Zo	$V_O = V_x$	3000			Ω	1
Voltage High	VHigh	Statistical measurement on single ended signal using oscilloscope math function.	660		850	mV	1
Voltage Low	VLow		-150		150		1
Max Voltage	Vovs	Measurement on single ended signal using absolute value.			1150	mV	1
Min Voltage	Vuds		-300				1
Crossing Voltage (abs)	Vcross(abs)		250		550	mV	1
Crossing Voltage (var)	d-Vcross	Variation of crossing over all edges			140	mV	1
Long Accuracy	ppm	see Tperiod min-max values	-300		300	ppm	1,2
Average period	Tperiod	400MHz nominal	2.4993		2.5008	ns	2
		400MHz spread	2.4993		2.5133	ns	2
		333.33MHz nominal	2.9991		3.0009	ns	2
		333.33MHz spread	2.9991		3.016	ns	2
		266.66MHz nominal	3.7489		3.7511	ns	2
		266.66MHz spread	3.7489		3.77	ns	2
		200MHz nominal	4.9985		5.0015	ns	2
		200MHz spread	4.9985		5.0266	ns	2
		166.66MHz nominal	5.9982		6.0018	ns	2
		166.66MHz spread	5.9982		6.0320	ns	2
		133.33MHz nominal	7.4978		7.5023	ns	2
		133.33MHz spread	7.4978		5.4000	ns	2
Absolute min period	T _{absmin}	400MHz nominal/spread	2.4143			ns	1,2
		333.33MHz nominal/spread	2.9141			ns	1,2
		266.66MHz nominal/spread	3.6639			ns	1,2
		200MHz nominal/spread	4.8735			ns	1,2
		166.66MHz nominal/spread	5.8732			ns	1,2
		133.33MHz nominal/spread	7.3728			ns	1,2
		100.00MHz nominal/spread	9.8720			ns	1,2
Rise Time	t _r	$V_{OL} = 0.175\text{V}$, $V_{OH} = 0.525\text{V}$	175		700	ps	1
Fall Time	t _f	$V_{OH} = 0.525\text{V}$, $V_{OL} = 0.175\text{V}$	175		700	ps	1
Rise Time Variation	d-t _r				125	ps	1
Fall Time Variation	d-t _f				125	ps	1
Duty Cycle	d _{t3}	Measurement from differential waveform	45		55	%	1
Skew	t _{sk3}	CPU (1:0) $V_T = 50\%$			100	ps	1
Skew	t _{sk4}	CPU (1:0) to CPU_ITP, $V_T = 50\%$			150	ps	1
Jitter, Cycle to cycle	t _{jcc-cyc}	Measurement from differential waveform			85	ps	1

¹Guaranteed by design, not 100% tested in production.

²All Long Term Accuracy and Clock Period specifications are guaranteed assuming that REFoutput is at 14.31818MHz

Electrical Characteristics - SRC 0.7V Current Mode Differential Pair
 $T_A = -40$ to 85°C ; $V_{DD} = 3.3\text{ V} \pm 5\%$; $C_L = 2\text{pF}$, $R_S = 33.2\Omega$, $R_P = 49.9\Omega$, $I_{REF} = 475\mu\text{A}$

PARAMETER	SYMBOL	CONDITIONS	MIN	TYP	MAX	UNITS	NOTES
Current Source Output Impedance	Zo	$V_O = V_x$	3000			Ω	1
Voltage High	VHigh	Statistical measurement on single ended signal using oscilloscope	660		850	mV	1
Voltage Low	VLow		-150		150		1
Max Voltage	Vovs	Measurement on single ended signal using absolute value.			1150	mV	1
Min Voltage	Vuds		-300				1
Crossing Voltage (abs)	Vcross(abs)		250	350	550	mV	1
Crossing Voltage (var)	d-Vcross	Variation of crossing over all edges		12	140	mV	1
Long Accuracy	ppm	see Tperiod min-max values	-300		300	ppm	1,2
Average period	Tperiod	100.00MHz nominal	9.9970		10.0030	ns	2
		100.00MHz spread	9.9970		10.0533	ns	2
Absolute min period	Tabsmn	100.00MHz nominal/spread	9.8720			ns	1,2
Rise Time	t _r	$V_{OL} = 0.175\text{V}$, $V_{OH} = 0.525\text{V}$	175		700	ps	1
Fall Time	t _f	$V_{OH} = 0.525\text{V}$, $V_{OL} = 0.175\text{V}$	175		700	ps	1
Rise Time Variation	d-t _r			30	125	ps	1
Fall Time Variation	d-t _f			30	125	ps	1
Duty Cycle	d _{t3}	Measurement from differential waveform	45		55	%	1
Skew	t _{sk3}	SRC(7:0), $V_T = 50\%$			250	ps	1
Jitter, Cycle to cycle	t _{jyc-cyc}	Measurement from differential waveform			125	ps	1

¹Guaranteed by design, not 100% tested in production.

²All Long Term Accuracy and Clock Period specifications are guaranteed assuming that REFoutput is at 14.31818MHz

Electrical Characteristics - PCICLK/PCICLK_FT_A = -40 to 85°C; V_{DD} = 3.3 V +/-5%; C_L = 30 pF (unless otherwise specified)

PARAMETER	SYMBOL	CONDITIONS	MIN	TYP	MAX	UNITS	Notes
Long Accuracy	ppm	see Tperiod min-max values	-300		300	ppm	1,2
Clock period	T _{period}	33.33MHz output nominal	29.99100		30.00900	ns	2
		33.33MHz output spread	29.99100		30.15980	ns	2
Absolute Min/Max Clock period	T _{abs}	33.33MHz output nominal	29.49100		30.50900	ns	2
		33.33MHz output spread	29.49100		30.65980	ns	2
Clk High Time	t _{h1}		12		N/A	ns	1
Clock Low Time	t _{l1}		12		N/A	ns	1
Output High Voltage	V _{OH}	I _{OH} = -1 mA	2.4			V	
Output Low Voltage	V _{OL}	I _{OL} = 1 mA			0.55	V	
Output High Current	I _{OH}	V _{OH} @ MIN = 1.0 V	-33			mA	
		V _{OH} @ MAX = 3.135 V			-33	mA	
Output Low Current	I _{OL}	V _{OL} @ MIN = 1.95 V	30			mA	
		V _{OL} @ MAX = 0.4 V			38	mA	
Edge Rate		Rising edge rate	1		4	V/ns	1
Edge Rate		Falling edge rate	1		4	V/ns	1
Rise Time	t _{r1}	V _{OL} = 0.4 V, V _{OH} = 2.4 V	0.5		2	ns	1
Fall Time	t _{f1}	V _{OH} = 2.4 V, V _{OL} = 0.4 V	0.5		2	ns	1
Duty Cycle	d _{t1}	V _T = 1.5 V	45		55	%	1
Skew	t _{sk1}	V _T = 1.5 V			500	ps	1
Jitter	t _{jyc-cyc}	V _T = 1.5 V			500	ps	1

¹Guaranteed by design, not 100% tested in production.²All Long Term Accuracy and Clock Period specifications are guaranteed assuming that REFOutput is at 14.31818MHz**Electrical Characteristics - USB_48MHz**T_A = -40 to 85°C; V_{DD} = 3.3 V +/-5%; C_L = 20 pF (unless otherwise specified)

PARAMETER	SYMBOL	CONDITIONS	MIN	TYP	MAX	UNITS	Notes
Long Accuracy	ppm	see Tperiod min-max values	-100		100	ppm	1,2
Clock period	T _{period}	48.0000MHz output nominal	20.82570		20.83400	ns	2
Absolute Min/Max Clock period	T _{abs}	Nominal	20.48125		21.18542	ns	2
Clk High Time	t _{h1}		8.094		10.036	ns	1
Clock Low Time	t _{l1}		7.694		9.836	ns	1
Output High Current	I _{OH}	V _{OH} @ MIN = 1.0 V	-33			mA	
		V _{OH} @ MAX = 3.135 V			-33	mA	
Output Low Current	I _{OL}	V _{OL} @ MIN = 1.95 V	30			mA	
		V _{OL} @ MAX = 0.4 V			38	mA	
Edge Rate		Rising edge rate	1		2	V/ns	1
Edge Rate		Falling edge rate	1		2	V/ns	1
Rise Time	t _{r1}	V _{OL} = 0.4 V, V _{OH} = 2.4 V	1	1.43	2	ns	1
Fall Time	t _{f1}	V _{OH} = 2.4 V, V _{OL} = 0.4 V	1	1.33	2	ns	1
Duty Cycle	d _{t1}	V _T = 1.5 V	45	48	55	%	1
Jitter, Cycle to cycle	t _{jyc-cyc}	V _T = 1.5 V			350	ps	1

¹Guaranteed by design, not 100% tested in production.²All Long Term Accuracy and Clock Period specifications are guaranteed assuming that REFOutput is at 14.31818MHz

Electrical Characteristics - DOT, 96MHz 0.7V Current Mode Differential Pair
 $T_A = -40$ to 85°C ; $V_{DD} = 3.3\text{ V} \pm 5\%$; $C_L = 2\text{pF}$, $R_S = 33.2\Omega$, $R_P = 49.9\Omega$, $I_{REF} = 475\mu\text{A}$

PARAMETER	SYMBOL	CONDITIONS	MIN	TYP	MAX	UNITS	NOTES
Current Source Output Impedance	Zo	$V_O = V_x$	3000			Ω	1
Voltage High	VHigh	Statistical measurement on single ended signal	660		850	mV	1
Voltage Low	VLow		-150		150		1
Max Voltage	Vovs	Measurement on single ended signal using			1150	mV	1
Min Voltage	Vuds		-300				1
Crossing Voltage (abs)	Vcross(abs)		250		550	mV	1
Crossing Voltage (var)	d-Vcross	Variation of crossing over all edges			140	mV	1
Long Accuracy	ppm	see Tperiod min-max values	-100		100	ppm	1,2
Average period	Tperiod	96.00MHz nominal	10.4135		10.4198	ns	2
Absolute min period	Tabsmin	96.00MHz nominal	10.1635			ns	1,2
Rise Time	t _r	$V_{OL} = 0.175\text{V}$, $V_{OH} = 0.525\text{V}$	175		700	ps	1
Fall Time	t _f	$V_{OH} = 0.525\text{V}$, $V_{OL} = 0.175\text{V}$	175		700	ps	1
Rise Time Variation	d-t _r				125	ps	1
Fall Time Variation	d-t _f				125	ps	1
Duty Cycle	d _{t3}	Measurement from differential waveform	45		55	%	1
Jitter, Cycle to cycle	t _{jyc-cyc}	Measurement from differential waveform			250	ps	1

¹Guaranteed by design, not 100% tested in production.

²All Long Term Accuracy and Clock Period specifications are guaranteed assuming that REFoutput is at 14.31818MHz
Electrical Characteristics - REF-14.318MHz
 $T_A = -40$ to 85°C ; $V_{DD} = 3.3\text{ V} \pm 5\%$; $C_L = 20\text{ pF}$ (unless otherwise specified)

PARAMETER	SYMBOL	CONDITIONS	MIN	TYP	MAX	UNITS	NOTES
Long Accuracy	ppm	see Tperiod min-max values	-300		300	ppm	1
Clock period	T _{period}	14.318MHz output nominal	69.82700		69.85500	ns	1
Absolute Min/Max Clock period	T _{abs}	Nominal	68.82033		70.86224	ns	2
Output High Voltage	V _{OH}	I _{OH} = -1 mA	2.4			V	1
Output Low Voltage	V _{OL}	I _{OL} = 1 mA			0.4	V	1
Output High Current	I _{OH}	V _{OH} @ MIN = 1.0 V, V _{OH} @ MAX = 3.135 V	-29		-23	mA	1
Output Low Current	I _{OL}	V _{OL} @ MIN = 1.95 V, V _{OL} @ MAX = 0.4 V	29		27	mA	1
Rise Time	t _{r1}	V _{OL} = 0.4 V, V _{OH} = 2.4 V	1		2	ns	1
Fall Time	t _{f1}	V _{OH} = 2.4 V, V _{OL} = 0.4 V	1		2	ns	1
Skew	t _{sk1}	V _T = 1.5 V			500	ps	1
Duty Cycle	d _{t1}	V _T = 1.5 V	45		55	%	1
Jitter	t _{jyc-cyc}	V _T = 1.5 V			1000	ps	1

¹Guaranteed by design, not 100% tested in production.

Test Clarification Table

Comments	HW		SW		OUTPUT
	FS_C/TEST_SEL HW PIN	FS_B/TEST_MODE HW PIN	TEST ENTRY BIT B6b6	REF/N or HI-Z B6b7	
	0	X	0	X	NORMAL
<ul style="list-style-type: none"> · FS_C/TEST_SEL is a 3-level latched input. <ul style="list-style-type: none"> o Power-up w/ V >= 2.0V to select TEST o Power-up w/ V < 2.0V to have pin function as FS_C. · When pin is FS_C, VIH_FS and VIL_FS levels apply. · FS_B/TEST_MODE is a low-threshold input <ul style="list-style-type: none"> o VIH_FS and VIL_FS levels apply. o TEST_MODE is a real time input · TEST_SEL can be invoked after power up through SMBus B6b6. <ul style="list-style-type: none"> o If TEST is selected by B6b6, only B6b7 controls TEST_MODE. The FS_B/TEST_Mode pin is not used. · Power must be cycled to exit TEST. 	1	0	X	0	HI-Z
	1	0	X	1	REF/N
	1	1	X	0	REF/N
	1	1	X	1	REF/N
	0	X	1	0	HI-Z
	0	X	1	1	REF/N
B6b6: 1= ENTER TEST MODE, Default = 0 (NORMAL OPERATION)					
B6b7: 1= REF/N, Default = 0 (HI-Z)					

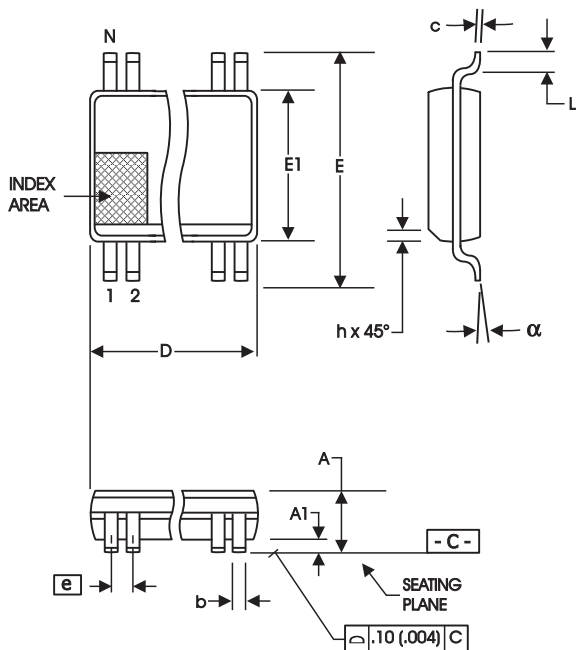

56-Lead, 300 mil Body, 25 mil, SSOP

SYMBOL	In Millimeters COMMON DIMENSIONS		In Inches COMMON DIMENSIONS	
	MIN	MAX	MIN	MAX
A	2.41	2.80	.095	.110
A1	0.20	0.40	.008	.016
b	0.20	0.34	.008	.0135
c	0.13	0.25	.005	.010
D	SEE VARIATIONS		SEE VARIATIONS	
E	10.03	10.68	.395	.420
E1	7.40	7.60	.291	.299
e	0.635 BASIC		0.025 BASIC	
h	0.38	0.64	.015	.025
L	0.50	1.02	.020	.040
N	SEE VARIATIONS		SEE VARIATIONS	
a	0°	8°	0°	8°

VARIATIONS

N	D mm.		D (inch)	
	MIN	MAX	MIN	MAX
56	18.31	18.55	.720	.730

Reference Doc.: JEDEC Publication 95, MO-118

10-0034

Ordering Information

9E4101yFILFT

Example:

XXXX y F ILFT

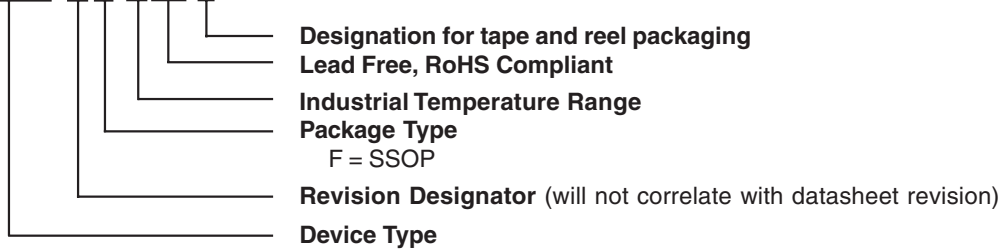

Revision History

Rev.	Issue Date	Description	Page #
0.1	10/25/07	Initial Release	-
0.2	07/11/08	Corrected operating temperature range on "Absolute Max" electrical characteristics table.	12
0.3	10/06/08	Corrected typo on ordering information.	19
0.4	01/07/09	Removed "Advanced Information" from document header.	Various
0.5	02/17/09	Added thermal chars.	12
A	01/25/10	Released to final. Updated document template.	

Innovate with IDT and accelerate your future networks. Contact:

www.IDT.com

For Sales

800-345-7015
408-284-8200
Fax: 408-284-2775

For Tech Support

408-284-6578
pcclockhelp@idt.com

Corporate Headquarters

Integrated Device Technology, Inc.
6024 Silver Creek Valley Road
San Jose, CA 95138
United States
800 345 7015
+408 284 8200 (outside U.S.)

Asia Pacific and Japan

Integrated Device Technology
Singapore (1997) Pte. Ltd.
Reg. No. 199707558G
435 Orchard Road
#20-03 Wisma Atria
Singapore 238877
+65 6 887 5505

Europe

IDT Europe, Limited
Prime House
Barnett Wood Lane
Leatherhead, Surrey
United Kingdom KT22 7DE
+44 1372 363 339



www.IDT.com