



AMD - K8™ System Clock Chip

Recommended Application:

AMD K8 System Clock with AMD, VIA or ALI Chipset

Output Features:

- 3 - Differential pair push-pull CPU clocks @ 3.3V
- 9 - PCICLK (Including 1 free running) @ 3.3V
- 3 - Selectable PCICLK/HTTCLK @ 3.3V
- 1 - HTTCLK @ 3.3V
- 1 - 48MHz @ 3.3V fixed.
- 1 - 24/48MHz @ 3.3V
- 2 - REF @ 3.3V, 14.318MHz.

Features:

- Programmable output frequency.
- Programmable output divider ratios.
- Programmable output rise/fall time.
- Programmable output skew.
- Programmable spread percentage for EMI control.
- Watchdog timer technology and RESET# output to reset system if system malfunctions.
- Programmable watch dog safe frequency.
- Support I²C Index read/write and block read/write operations.
- Uses external 14.318MHz crystal.
- Supports Hyper Transport Technology (HTTCLK).

Pin Configuration

~*FS0/REF0	1	48	REF1/FS1*
VDDHTT	2	47	GND
X1	3	46	VDDREF
X2	4	45	Reset#
GND	5	44	VDDA
*ModeA/HTTCLK0	6	43	GND
*ModeB/PCICLK8/HTTCLK1	7	42	CPUCLK8T0
PCICLK9/HTTCLK2	8	41	CPUCLK8C0
VDDPCI	9	40	VDDCPU
GND	10	39	CPUCLK8T1
PCICLK11/HTTCLK3	11	38	CPUCLK8C1
*FS2/PCICLK10	12	37	GND
PCICLK0	13	36	VDDCPU
PCICLK1	14	35	CPUCLK8T2
GND	15	34	CPUCLK8C2
VDDPCI	16	33	GND
PCICLK2	17	32	Turbo#
PCICLK3	18	31	PD#*
VDDPCI	19	30	48MHz/FS3**
GND	20	29	GND
^{2X} PCICLK4	21	28	AVDD48
^{2X} PCICLK5	22	27	24_48MHz/Sel24_48#*
^{2X} PCICLK6	23	26	SDATA
^{2X} PCICLK7	24	25	SCLK

48-SSOP

* Internal Pull-Up Resistor

^{2X} This Output has 2X Default Drive and can be programmed lower via IIC

~ This Output has 1.5x drive

Functionality

FS3	FS2	FS1	FS0	CPU	HTT	PCI
				MHz	MHz	MHz
0	0	0	0	100.90	67.27	33.63
0	0	0	1	133.90	66.95	33.48
0	0	1	0	168.00	67.20	33.60
0	0	1	1	202.00	67.33	33.67
0	1	0	0	100.20	66.80	33.40
0	1	0	1	133.50	66.75	33.38
0	1	1	0	166.70	66.68	33.34
0	1	1	1	200.40	66.80	33.40
1	0	0	0	150.00	60.00	30.00
1	0	0	1	180.00	60.00	30.00
1	0	1	0	210.00	70.00	35.00
1	0	1	1	240.00	60.00	30.00
1	1	0	0	270.00	67.50	33.75
1	1	0	1	233.33	66.67	33.33
1	1	1	0	266.67	66.67	33.33
1	1	1	1	300.00	75.00	37.50



Pin Descriptions

PIN #	PIN NAME	PIN TYPE	DESCRIPTION
1	~*FS0/REF0	I/O	Frequency select latch input pin / 14.318 MHz reference clock.
2	VDDHTT	PWR	Supply for HTT clocks, nominal 3.3V.
3	X1	IN	Crystal input, Nominally 14.318MHz.
4	X2	OUT	Crystal output, Nominally 14.318MHz
5	GND	PWR	Ground pin.
6	*ModeA/HTTCLK0	I/O	Mode selection latch input pin / Hyper Transport output.
7	*ModeB/PCICLK8/HTTCLK1	I/O	Mode selection latch input pin / PCI clock output / Hyper Transport output.
8	PCICLK9/HTTCLK2	OUT	PCI clock output / Hyper Transport output.
9	VDDPCI	PWR	Power supply for PCI clocks, nominal 3.3V
10	GND	PWR	Ground pin.
11	PCICLK11/HTTCLK3	OUT	PCI clock output / Hyper Transport output.
12	*FS2/PCICLK10	I/O	Frequency select latch input pin / 3.3V PCI clock output.
13	PCICLK0	OUT	PCI clock output.
14	PCICLK1	OUT	PCI clock output.
15	GND	PWR	Ground pin.
16	VDDPCI	PWR	Power supply for PCI clocks, nominal 3.3V
17	PCICLK2	OUT	PCI clock output.
18	PCICLK3	OUT	PCI clock output.
19	VDDPCI	PWR	Power supply for PCI clocks, nominal 3.3V
20	GND	PWR	Ground pin.
21	2XPCICLK4	OUT	PCI clock output. This output is default @ 2X drive and can be programmed to lower drive via IIC.
22	2XPCICLK5	OUT	PCI clock output. This output is default @ 2X drive and can be programmed to lower drive via IIC.
23	2XPCICLK6	OUT	PCI clock output. This output is default @ 2X drive and can be programmed to lower drive via IIC.
24	2XPCICLK7	OUT	PCI clock output. This output is default @ 2X drive and can be programmed to lower drive via IIC.
25	SCLK	IN	Clock pin of SMBus circuitry, 5V tolerant.
26	SDATA	I/O	Data pin for SMBus circuitry, 5V tolerant.
27	24_48MHz/Sel24_48#*	I/O	24/48MHz clock output / Latched select input for 24/48MHz output. 0=48MHz, 1 = 24MHz.
28	AVDD48	PWR	Analog power for 48MHz outputs and fixed PLL core, nominal 3.3V
29	GND	PWR	Ground pin.
30	48MHz/FS3**	I/O	Fixed 48MHz clock output. 3.3V / 'Frequency select latch input pin
31	PD#*	IN	Asynchronous active low input pin used to power down the device. The internal clocks are disabled and the VCO and the crystal are stopped.
32	Turbo#	IN	Real time input pin to change frequency to a pre-programmed under or over clock entries located in IIC Rom table.
33	GND	PWR	Ground pin.
34	CPUCLK8C2	OUT	Complimentary clock of differential 3.3V push-pull K8 pair.
35	CPUCLK8T2	OUT	True clock of differential 3.3V push-pull K8 pair.
36	VDDCPU	PWR	Supply for CPU clocks, 3.3V nominal
37	GND	PWR	Ground pin.
38	CPUCLK8C1	OUT	Complimentary clock of differential 3.3V push-pull K8 pair.
39	CPUCLK8T1	OUT	True clock of differential 3.3V push-pull K8 pair.
40	VDDCPU	PWR	Supply for CPU clocks, 3.3V nominal
41	CPUCLK8C0	OUT	Complimentary clock of differential 3.3V push-pull K8 pair.
42	CPUCLK8T0	OUT	True clock of differential 3.3V push-pull K8 pair.
43	GND	PWR	Ground pin.
44	VDDA	PWR	3.3V power for the PLL core.
45	Reset#	OUT	Real time system reset signal for frequency gear ratio change or watchdog timer timeout. This signal is active low.
46	VDDREF	PWR	Ref, XTAL power supply, nominal 3.3V
47	GND	PWR	Ground pin.
48	REF1/FS1*	I/O	14.318 MHz reference clock / Frequency select latch input pin.

* Internal Pull-Up Resistor ** Internal Pull-Down Resistor ~ 1.5X Drive Strength



General Description

The **ICS950410** is a main system clock solution for desktop designs using the AMD K8 CPU. It provides all necessary clock signals for Clawhammer and Sledgehammer with AMD, VIA or ALI systems.

The **ICS950410** is part of a whole new line of ICS clock generators and buffers called TCH™ (Timing Control Hub). This part incorporates ICS's newest clock technology which offers more robust features and functionality. Employing the use of a serially programmable I²C interface, this device can adjust the output clocks by configuring the frequency setting, the output divider ratios, selecting the ideal spread percentage, the output skew, the output strength, and enabling/disabling each individual output clock. M/N control can configure output frequency with resolution up to 0.1MHz increment.

Block Diagram

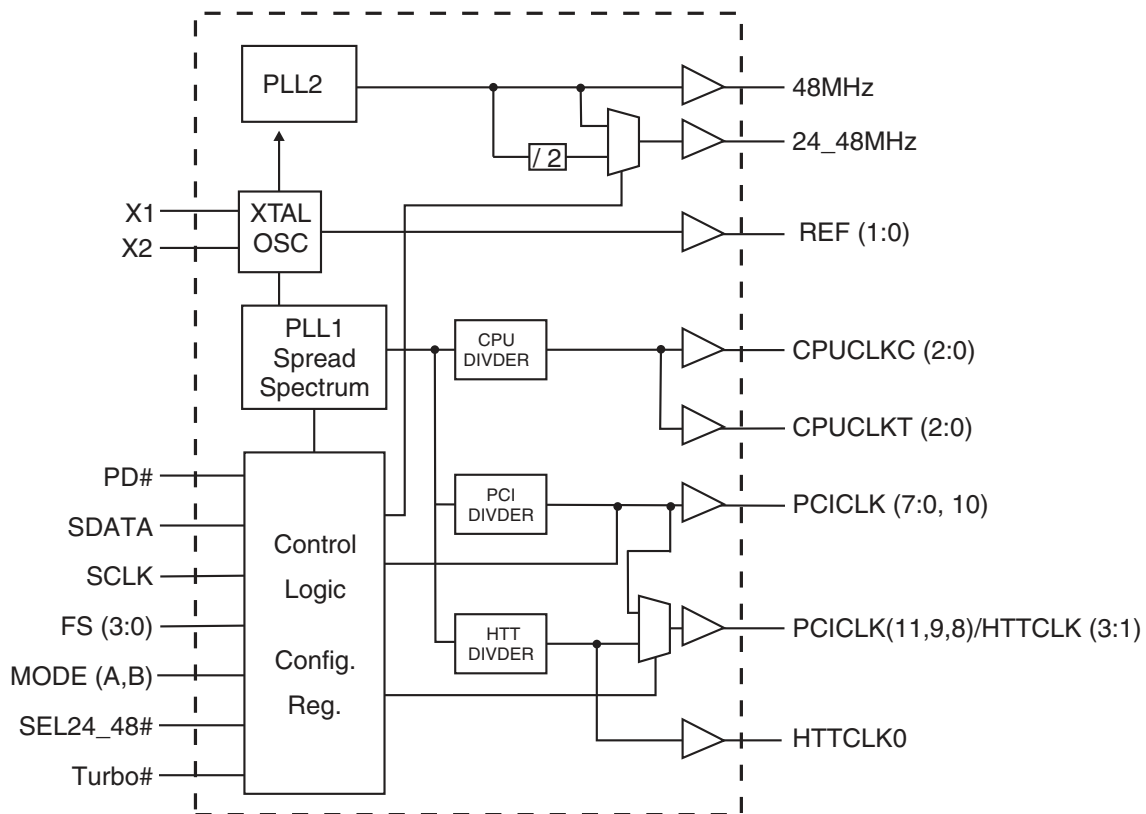

Power Groups

Pin Number		Description
VDD	GND	
2	5	Xtal, POR
9	10	PCICLK, HTTCLK O/p
16,19	15,20	PCICLK Outputs
29	27,30,33	48 MHz, Fix Analog
35,38	34,39	CPU Outputs
43	42	Analog, CPU PLL, MCLK
46	47	REF, Digital Core



Table1: Frequency Selection Table

Bit4	Bit3	Bit2	Bit1	Bit0	CPU	HTT	PCI
FS4	FS3	FS2	FS1	FS0	MHz	MHz	MHz
0	0	0	0	0	100.90	67.27	33.63
0	0	0	0	1	133.90	66.95	33.48
0	0	0	1	0	168.00	67.20	33.60
0	0	0	1	1	202.00	67.33	33.67
0	0	1	0	0	100.20	66.80	33.40
0	0	1	0	1	133.50	66.75	33.38
0	0	1	1	0	166.70	66.68	33.34
0	0	1	1	1	200.40	66.80	33.40
0	1	0	0	0	150.00	60.00	30.00
0	1	0	0	1	180.00	60.00	30.00
0	1	0	1	0	210.00	70.00	35.00
0	1	0	1	1	240.00	60.00	30.00
0	1	1	0	0	270.00	67.50	33.75
0	1	1	0	1	233.33	66.67	33.33
0	1	1	1	0	266.67	66.67	33.33
0	1	1	1	1	300.00	75.00	37.50
1	0	0	0	0	100.00	66.67	33.33
1	0	0	0	1	133.33	66.67	33.33
1	0	0	1	0	166.66	66.66	33.33
1	0	0	1	1	200.00	66.67	33.33
1	0	1	0	0	103.00	68.67	34.33
1	0	1	0	1	137.33	68.66	34.33
1	0	1	1	0	171.66	68.66	34.33
1	0	1	1	1	206.00	68.67	34.33
1	1	0	0	0	154.49	61.79	30.90
1	1	0	0	1	185.38	61.79	30.90
1	1	0	1	0	216.31	72.10	36.05
1	1	0	1	1	247.20	61.80	30.90
1	1	1	0	0	278.10	69.53	34.76
1	1	1	0	1	240.34	68.67	34.33
1	1	1	1	0	274.68	68.67	34.34
1	1	1	1	1	308.97	77.24	38.62

Mode Functionality Tables

ModeA	ModeB	Pin7	Pin8	Pin11
0	0	HTTCLK1	HTTCLK2	PCICLK11
0	1	HTTCLK1	HTTCLK2	HTTCLK3
1	0	PCICLK8	PCICLK9	PCICLK11
1	1	HTTCLK1	PCICLK9	PCICLK11



General I²C serial interface information

How to Write:

- Controller (host) sends a start bit.
- Controller (host) sends the write address $D2_{(H)}$
- ICS clock will **acknowledge**
- Controller (host) sends the beginning byte location = N
- ICS clock will **acknowledge**
- Controller (host) sends the data byte count = X
- ICS clock will **acknowledge**
- Controller (host) starts sending **Byte N through Byte N + X - 1**
(see Note 2)
- ICS clock will **acknowledge** each byte **one at a time**
- Controller (host) sends a Stop bit

How to Read:

- Controller (host) will send start bit.
- Controller (host) sends the write address $D2_{(H)}$
- ICS clock will **acknowledge**
- Controller (host) sends the beginning byte location = N
- ICS clock will **acknowledge**
- Controller (host) will send a separate start bit.
- Controller (host) sends the read address $D3_{(H)}$
- ICS clock will **acknowledge**
- ICS clock will send the data byte count = X
- ICS clock sends **Byte N + X - 1**
- ICS clock sends **Byte 0 through byte X (if $X_{(H)}$ was written to byte 8)**.
- Controller (host) will need to acknowledge each byte
- Controller (host) will send a not acknowledge bit
- Controller (host) will send a stop bit

Index Block Write Operation		
Controller (Host)		ICS (Slave/Receiver)
T	starT bit	
Slave Address $D2_{(H)}$		
WR	WRite	
		ACK
Beginning Byte = N		
		ACK
Data Byte Count = X		
		ACK
Beginning Byte N	X Byte	ACK
○		○
○		○
○		○
Byte N + X - 1		○
		ACK
P	stoP bit	

Index Block Read Operation			
Controller (Host)		ICS (Slave/Receiver)	
T	starT bit		
Slave Address $D2_{(H)}$			
WR	WRite		
		ACK	
Beginning Byte = N			
		ACK	
RT	Repeat starT		
Slave Address $D3_{(H)}$			
RD	ReaD		
		ACK	
		Data Byte Count = X	
ACK			
ACK		Beginning Byte N	
		X Byte	○
			○
			○
			○
		Byte N + X - 1	
N	Not acknowledge		
P	stoP bit		

ICS950410

Preliminary Product Preview



I²C Table: Frequency Select Register

Byte 0		Pin #	Name	Control Function	Type	0	1	PWD
Bit 7	-		SS_EN	Spread Enable	RW	OFF	ON	1
Bit 6	-		SEL24_48MHz	Output Select	RW	48MHz	24MHz	Latch
Bit 5	-		FS Source Select	FS Source Select	RW	latch	I2C	0
Bit 4	-		FS4	Freq Select Bit 4	RW	See Table1: Frequency Selection Table		0
Bit 3	-		FS3	Freq Select Bit 3	RW			Latch
Bit 2	-		FS2	Freq Select Bit 2	RW			Latch
Bit 1	-		FS1	Freq Select Bit 1	RW			Latch
Bit 0	-		FS0	Freq Select Bit 0	RW			Latch

I²C Table: Output Control Register

Byte 1		Pin #	Name	Control Function	Type	0	1	PWD
Bit 7	1		CPUCLK8T/C2	Output Control	RW	Disable	Enable	1
Bit 6	6		HTTCLK0	Output Control	RW	Disable	Enable	1
Bit 5	7		PCICLK8/HTTCLK1	Output Control	RW	Disable	Enable	1
Bit 4	8		PCICLK9/HTTCLK2	Output Control	RW	Disable	Enable	1
Bit 3	11		PCICLK11/HTTCLK3	Output Control	RW	Disable	Enable	1
Bit 2	12		PCICLK10	Output Control	RW	Disable	Enable	1
Bit 1	13		PCICLK0	Output Control	RW	Disable	Enable	1
Bit 0	14		PCICLK1	Output Control	RW	Disable	Enable	1

I²C Table: Output Control Register

Byte 2		Pin #	Name	Control Function	Type	0	1	PWD
Bit 7	17		PCICLK2	Output Control	RW	Disable	Enable	1
Bit 6	18		PCICLK3	Output Control	RW	Disable	Enable	1
Bit 5	21		PCICLK4	Output Control	RW	Disable	Enable	1
Bit 4	22		PCICLK5	Output Control	RW	Disable	Enable	1
Bit 3	23		PCICLK6	Output Control	RW	Disable	Enable	1
Bit 2	24		PCICLK7	Output Control	RW	Disable	Enable	1
Bit 1	28		24_48MHz	Output Control	RW	Disable	Enable	1
Bit 0	31		48MHz	Output Control	RW	Disable	Enable	1

I²C Table: Output Control Register

Byte 3		Pin #	Name	Control Function	Type	0	1	PWD
Bit 7	37,36		CPUCLK8T/C_1	Output Control	RW	Disable	Enable	1
Bit 6	41,40		CPUCLK8T/C_0	Output Control	RW	Disable	Enable	1
Bit 5			Reserved	Reserved	RW	-	-	1
Bit 4	45,48		REF0/REF1	Output Control	RW	Disable	Enable	1
Bit 3	-		PCI_Str1	PCI9,8 Strength Control only	RW	00: 0.5X Drive	10: 1.5X Drive	0
Bit 2	-		PCI_Str0		RW	01: 1.0X Drive	11: 2.0X Drive	1
Bit 1	-		PCI_Str1	PCI11 Strength Control only	RW	00: 0.5X Drive	10: 1.5X Drive	0
Bit 0	-		PCI_Str0		RW	01: 1.0X Drive	11: 2.0X Drive	1



I²C Table: Output Control Register

Byte 4		Pin #	Name	Control Function	Type	0	1	PWD
Bit 7	-		PCIStr1	All other PCICLK Strength Control	RW	00: 0.5X Drive	10: 1.5X Drive	0
Bit 6	-		PCIStr0		RW	01: 1.0X Drive	11: 2.0X Drive	1
Bit 5	-		PCIStr1	PCICLK (7:6) Strength Control	RW	00: 0.5X Drive	10: 1.5X Drive	1
Bit 4	-		PCIStr0		RW	01: 1.0X Drive	11: 2.0X Drive	1
Bit 3	-		PCIStr1	PCICLK (5) Strength Control	RW	00: 0.5X Drive	10: 1.5X Drive	1
Bit 2	-		PCIStr0		RW	01: 1.0X Drive	11: 2.0X Drive	1
Bit 1	-		PCIStr1	PCICLK (4) Strength Control	RW	00: 0.5X Drive	10: 1.5X Drive	1
Bit 0	-		PCIStr0		RW	01: 1.0X Drive	11: 2.0X Drive	1

I²C Table: Reserved Register

Byte 5		Pin #	Name	Control Function	Type	0	1	PWD
Bit 7	-		Reserved	Reserved	RW	Reserved	Reserved	X
Bit 6	-		Reserved	Reserved	RW	Reserved	Reserved	X
Bit 5	-		Reserved	Reserved	RW	Reserved	Reserved	X
Bit 4	-		Reserved	Reserved	RW	Reserved	Reserved	X
Bit 3	-		Reserved	Reserved	RW	Reserved	Reserved	X
Bit 2	-		Reserved	Reserved	RW	Reserved	Reserved	X
Bit 1	-		Reserved	Reserved	RW	Reserved	Reserved	X
Bit 0	-		Reserved	Reserved	RW	Reserved	Reserved	X

I²C Table: Byte Count Register

Byte 6		Pin #	Name	Control Function	Type	0	1	PWD
Bit 7	-		BC7	Byte Count Programming b(7:0)	RW	Writing to this register will configure how many bytes will be read back, default is 06 = 6 bytes.		0
Bit 6	-		BC6		RW			0
Bit 5	-		BC5		RW			0
Bit 4	-		BC4		RW			0
Bit 3	-		BC3		RW			0
Bit 2	-		BC2		RW			1
Bit 1	-		BC1		RW			1
Bit 0	-		BC0		RW			0

I²C Table: Byte Count and Vendor ID Register

Byte 7		Pin #	Name	Control Function	Type	0	1	PWD
Bit 7	-		REV_ID3	Revision ID	RW	-	-	0
Bit 6	-		REV_ID2		RW	-	-	0
Bit 5	-		REV_ID1		RW	-	-	0
Bit 4	-		REV_ID0		RW	-	-	0
Bit 3	-		Vendor_ID3	Vendor ID	RW	-	-	0
Bit 2	-		Vendor_ID2		RW	-	-	0
Bit 1	-		Vendor_ID1		RW	-	-	0
Bit 0	-		Vendor_ID0		RW	-	-	1

ICS950410

Preliminary Product Preview



I²C Table: Skew Control Register

Byte 8		Pin #	Name	Control Function	Type	0		1		PWD
Bit 7	-	-	PCI/HTTSkw3	CPU-PCI/HTT 7 Step Skew Control (ps)	RW	0000:0	0100:150	1000:300	1100:450	1
Bit 6	-	-	PCI/HTTSkw2		RW	0001:N/A	0101:N/A	1001:N/A	1101:600	1
Bit 5	-	-	PCI/HTTSkw1		RW	0010:N/A	0110:N/A	1010:N/A	1110:750	0
Bit 4	-	-	PCI/HTTSkw0		RW	0011:N/A	0111:N/A	1011:N/A	1111:900	0
Bit 3	-	-	PCISkw3	CPU-PCI 7 Step Skew Control (ps)	RW	0000:0	0100:150	1000:300	1100:450	1
Bit 2	-	-	PCISkw2		RW	0001:N/A	0101:N/A	1001:N/A	1101:600	1
Bit 1	-	-	PCISkw1		RW	0010:N/A	0110:N/A	1010:N/A	1110:750	0
Bit 0	-	-	PCISkw0		RW	0011:N/A	0111:N/A	1011:N/A	1111:900	0

I²C Table: WD Time Control & Async Frequency Selection Register

Byte 9		Pin #	Name	Control Function	Type	0		1		PWD
Bit 7	-	-	ASEL	Async Frequency Select	RW	66MHz		75.4MHz		0
Bit 6	-	-	AEN	AGP/PCI/ Freq Source Select	RW	FIX PLL		CPU PLL		1
Bit 5	-	-	REF1 Strength	REF1 strength control	RW	1x		2x		1
Bit 4	-	-	Reserved	Reserved	RW	-		-		1
Bit 3	-	-	WDTCtrl	Watch Dog Time base Control	RW	290ms Base		1160ms Base		0
Bit 2	-	-	WD2	WD Timer Bit 2	RW	These bits represent X*290ms (or 1.16S) the watchdog timer waits before it goes to alarm mode. Default is 7 X 290ms = 2s.				1
Bit 1	-	-	WD1	WD Timer Bit 1	RW					1
Bit 0	-	-	WD0	WD Timer Bit 0	RW					1

I²C Table: VCO Control Select Bit & WD Timer Control Register

Byte 10		Pin #	Name	Control Function	Type	0		1		PWD
Bit 7	-	-	M/NEN	M/N Programming Enable	RW	Disable		Enable		0
Bit 6	-	-	WDEN	Watchdog Enable	RW	Disable		Enable		0
Bit 5	-	-	WDStatus	WD Alarm Status	R	Normal		Alarm		0
Bit 4	-	-	WD SF4	Watch Dog Safe Freq Programming bits	RW	Writing to these bit will configure the safe frequency as Byte0 bit (4:0).				0
Bit 3	-	-	WD SF3		RW					0
Bit 2	-	-	WD SF2		RW					0
Bit 1	-	-	WD SF1		RW					0
Bit 0	-	-	WD SF0		RW					0

I²C Table: VCO Frequency Control Register

Byte 11		Pin #	Name	Control Function	Type	0		1		PWD
Bit 7	-	-	N Div8	N Divider Prog bit 8	RW	The decimal representation of N Divider in Byte 11 and 12				X
Bit 6	-	-	N Div9	N Divider Prog bit 9	RW					X
Bit 5	-	-	M Div5	M Divider Programming bits (5:0)	RW	The decimal representation of M and N Divider in Byte 11 and 12 will configure the VCO frequency. Default at power up = latch-in or Byte 0 Rom table. VCO Frequency = 14.318 x [NDiv(9:0)+8] / [MDiv(5:0)+2]				X
Bit 4	-	-	M Div4		RW					X
Bit 3	-	-	M Div3		RW					X
Bit 2	-	-	M Div2		RW					X
Bit 1	-	-	M Div1		RW					X
Bit 0	-	-	M Div0	RW	X					



I²C Table: VCO Frequency Control Register

Byte 12		Pin #	Name	Control Function	Type	0	1	PWD
Bit 7	-	-	N Div7	N Divider Programming bit (7:0)	RW	The decimal representation of M and N Divier in Byte 11 and 12 will configure the VCO frequency. Default at power up = latch-in or Byte 0 Rom table. VCO Frequency = $14.318 \times [\text{NDiv}(9:0)+8] / [\text{MDiv}(5:0)+2]$		X
Bit 6	-	-	N Div6		RW			X
Bit 5	-	-	N Div5		RW			X
Bit 4	-	-	N Div4		RW			X
Bit 3	-	-	N Div3		RW			X
Bit 2	-	-	N Div2		RW			X
Bit 1	-	-	N Div1		RW			X
Bit 0	-	-	N Div0		RW			X

I²C Table: Spread Spectrum Control Register

Byte 13		Pin #	Name	Control Function	Type	0	1	PWD
Bit 7	-	-	SSP7	Spread Spectrum Programming b(7:0)	RW	These Spread Spectrum bits in Byte 13 and 14 will program the spread percentage. It is recommended to use ICS Spread % table for spread programming.		X
Bit 6	-	-	SSP6		RW			X
Bit 5	-	-	SSP5		RW			X
Bit 4	-	-	SSP4		RW			X
Bit 3	-	-	SSP3		RW			X
Bit 2	-	-	SSP2		RW			X
Bit 1	-	-	SSP1		RW			X
Bit 0	-	-	SSP0		RW			X

I²C Table: Spread Spectrum Control Register

Byte 14		Pin #	Name	Control Function	Type	0	1	PWD
Bit 7	-	-	Reserved	Reserved	R	-	-	0
Bit 6	-	-	SSP14	Spread Spectrum Programming b(14:8)	RW	These Spread Spectrum bits in Byte 13 and 14 will program the spread percentage. It is recommended to use ICS Spread % table for spread programming.		X
Bit 5	-	-	SSP13		RW			X
Bit 4	-	-	SSP12		RW			X
Bit 3	-	-	SSP11		RW			X
Bit 2	-	-	SSP10		RW			X
Bit 1	-	-	SSP9		RW			X
Bit 0	-	-	SSP8		RW			X



Absolute Maximum Rating

PARAMETER	SYMBOL	CONDITIONS	MIN	TYP	MAX	UNITS	Notes
3.3V Core Supply Voltage	VDD_A	-			V _{DD} + 0.5V	V	1
3.3V Logic Input Supply Voltage	VDD_In	-	GND - 0.5		V _{DD} + 0.5V	V	1
Storage Temperature	T _s	-	-65		150	°C	1
Ambient Operating Temp	T _{ambient}	-	0		70	°C	1
Case Temperature	T _{case}	-			115	°C	1
Input ESD protection HBM	ESD prot	-	2000			V	1

¹Guaranteed by design and characterization, not 100% tested in production.

Electrical Characteristics - Input/Supply/Common Output Parameters

PARAMETER	SYMBOL	CONDITIONS*	MIN	TYP	MAX	UNITS	Notes
Input High Voltage	V _{IH}	3.3 V +/-5%	2		V _{DD} + 0.3	V	1
Input Low Voltage	V _{IL}	3.3 V +/-5%	V _{SS} - 0.3		0.8	V	1
Input High Current	I _{IH}	V _{IN} = V _{DD}	-5		5	uA	1
Input Low Current	I _{IL1}	V _{IN} = 0 V; Inputs with no pull-up resistors	-5			uA	1
	I _{IL2}	V _{IN} = 0 V; Inputs with pull-up resistors	-200			uA	1
Low Threshold Input-High Voltage	V _{IH_FS}	3.3 V +/-5%	0.7		V _{DD} + 0.3	V	1
Low Threshold Input-Low Voltage	V _{IL_FS}	3.3 V +/-5%	V _{SS} - 0.3		0.35	V	1
Operating Supply Current	I _{DD3.3OP}	Full Active, C _L = Full load;			350	mA	1
Operating Current	I _{DD3.3OP}	all outputs driven			400	mA	1
Powerdown Current	I _{DD3.3PD}	all diff pairs driven			70	mA	1
		all differential pairs tri-stated			12	mA	1
Input Frequency	F _i	V _{DD} = 3.3 V		14.31818		MHz	2
Pin Inductance	L _{pin}				7	nH	1
Input Capacitance	C _{IN}	Logic Inputs			5	pF	1
	C _{OUT}	Output pin capacitance			6	pF	1
	C _{INX}	X1 & X2 pins			5	pF	1
Clk Stabilization	T _{STAB}	From V _{DD} Power-Up or de-assertion of PD# to 1st clock			1.8	ms	1
Modulation Frequency		Triangular Modulation	30		33	kHz	1
Tdrive_PD#		CPU output enable after PD# de-assertion			300	us	1
Tfall_Pd#		PD# fall time of			5	ns	1
Trise_Pd#		PD# rise time of			5	ns	1
SMBus Voltage	V _{DD}		2.7		5.5	V	1
Low-level Output Voltage	V _{OL}	@ I _{PULLUP}			0.4	V	1
Current sinking at V _{OL} = 0.4 V	I _{PULLUP}		4			mA	1
SCLK/SDATA Clock/Data Rise Time	T _{RI2C}	(Max VIL - 0.15) to (Min VIH + 0.15)			1000	ns	1
SCLK/SDATA Clock/Data Fall Time	T _{FI2C}	(Min VIH + 0.15) to (Max VIL - 0.15)			300	ns	1

*TA = 0 - 70°C; Supply Voltage VDD = 3.3 V +/-5%

¹Guaranteed by design and characterization, not 100% tested in production.

² Input frequency should be measured at the REF pin and tuned to ideal 14.31818MHz to meet ppm frequency accuracy on PLL outputs.



Electrical Characteristics - PCICLK/PCICLK_F

PARAMETER	SYMBOL	CONDITIONS*	MIN	TYP	MAX	UNITS	NOTES
Output Impedance	R_{DSP}	$V_O = V_{DD} * (0.5)$	12		55	Ω	1
Output High Voltage	V_{OH}	$I_{OH} = -1 \text{ mA}$	2.4			V	1
Output Low Voltage	V_{OL}	$I_{OL} = 1 \text{ mA}$			0.55	V	1
Output High Current	I_{OH}	$V_{OH} @ \text{MIN} = 1.0 \text{ V}$	-33			mA	1
		$V_{OH} @ \text{MAX} = 3.135 \text{ V}$			-33	mA	1
Output Low Current	I_{OL}	$V_{OL} @ \text{MIN} = 1.95 \text{ V}$	30			mA	1
		$V_{OL} @ \text{MAX} = 0.4 \text{ V}$			38	mA	1
Edge Rate	t_{slewrf}	Rising/Falling edge rate	1		4	V/ns	1
Rise Time	t_r	$V_{OL} = 0.4 \text{ V}, V_{OH} = 2.4 \text{ V}$	0.5		2	ns	1
Fall Time	t_f	$V_{OH} = 2.4 \text{ V}, V_{OL} = 0.4 \text{ V}$	0.5		2	ns	1
Duty Cycle	d_{t1}	$V_T = 1.5 \text{ V}$	45		55	%	1
Group Skew	t_{skew}	$V_T = 1.5 \text{ V}$			250	ps	1
Jitter, Cycle to cycle	$t_{cyc-cyc}$	$V_T = 1.5 \text{ V}$			500	ps	1

*TA = 0 - 70°C; Supply Voltage VDD = 3.3 V +/-5%, CL = 20 pF with Rs = 7 Ω (unless otherwise specified)

¹Guaranteed by design and characterization, not 100% tested in production.

³ Spread Spectrum is off

Electrical Characteristics - 48MHz/USB48MHz/24_48MHz

PARAMETER	SYMBOL	CONDITIONS*	MIN	TYP	MAX	UNITS	NOTES
Long Accuracy	ppm	see Tperiod min-max values	-100		100	ppm	1,2
Clock period	T_{period}	48.00MHz output nominal	20.8313		20.8354	ns	2
Output Impedance	R_{DSP}	$V_O = V_{DD} * (0.5)$	12		55	Ω	1
Output High Voltage	V_{OH}	$I_{OH} = -1 \text{ mA}$	2.4			V	1
Output Low Voltage	V_{OL}	$I_{OL} = 1 \text{ mA}$			0.55	V	1
Output High Current	I_{OH}	$V_{OH} @ \text{MIN} = 1.0 \text{ V}$	-33			mA	1
		$V_{OH} @ \text{MAX} = 3.135 \text{ V}$			-33	mA	1
Output Low Current	I_{OL}	$V_{OL} @ \text{MIN} = 1.95 \text{ V}$	30			mA	1
		$V_{OL} @ \text{MAX} = 0.4 \text{ V}$			38	mA	1
Edge Rate	t_{slewrf}	Rising/Falling edge rate	1		4	V/ns	1
Edge Rate	t_{slewrf_USB}	USB48 Rising/Falling edge rate	1		2	V/ns	1
Rise Time	t_r	$V_{OL} = 0.4 \text{ V}, V_{OH} = 2.4 \text{ V}$	0.5		2	ns	1
Fall Time	t_f	$V_{OH} = 2.4 \text{ V}, V_{OL} = 0.4 \text{ V}$	0.5		2	ns	1
Rise Time	t_{r_USB}	$V_{OL} = 0.4 \text{ V}, V_{OH} = 2.4 \text{ V}$	1		2	ns	1
Fall Time	t_{f_USB}	$V_{OH} = 2.4 \text{ V}, V_{OL} = 0.4 \text{ V}$	1		2	ns	1
Duty Cycle	d_{t1}	$V_T = 1.5 \text{ V}$	45		55	%	1
Group Skew	t_{skew}	$V_T = 1.5 \text{ V}$			250	ps	1
Jitter, Cycle to cycle	$t_{cyc-cyc}$	$V_T = 1.5 \text{ V}$			500	ps	1

*TA = 0 - 70°C; Supply Voltage VDD = 3.3 V +/-5%, CL = 20 pF with Rs = 7 Ω (Rs is used in USB48MHz test only)

¹Guaranteed by design and characterization, not 100% tested in production.



Electrical Characteristics - CPUCLK8T/C K8 3.3V Push Pull Differential Pair

PARAMETER	SYMBOL	CONDITIONS*	MIN	TYP	MAX	UNITS	NOTES
Rising Edge Rate	$\delta V/\delta t$	At CPU's test load. 0 V +/- 400 mV (differential measurement)	2		10	V/ns	1
Falling Edge Rate	$\delta V/\delta t$		2		10	V/ns	1
Differential Voltage	V_{DIFF}	At CPU's test load. (single-ended measurement)	0.4		2.3	V	1
Change in V_{DIFF_DC} Magnitude	ΔV_{DIFF}		-150		150	mV	1
Common Mode Voltage	V_{CM}		1.05		1.45	V	1
Change in Common Mode Voltage	ΔV_{CM}		-200		200	mV	1
Jitter, Cycle to cycle	$t_{j\text{cyc-cyc}}$	Measurement from differential waveform	0		200	ps	1
Jitter, Accumulated	t_{ja}		-1000		1000		1,2,3
Duty Cycle	d_{D3}	Measurement from differential waveform	45		55	%	1
Output Impedance	R_{ON}	Average value during switching transition. Used for determining series termination value.	15		55	Ω	1
Group Skew	t_{skew}	Measurement from differential waveform			250	ps	1

*TA = 0 - 70°C; Supply Voltage VDD = 3.3 V +/-5%

¹Guaranteed by design and characterization, not 100% tested in production.

²All accumulated jitter specifications are guaranteed assuming that REF is at 14.31818MHz

³Spread Spectrum is off

Electrical Characteristics - HTTCLK

PARAMETER	SYMBOL	CONDITIONS*	MIN	TYP	MAX	UNITS	NOTES
Output Impedance	Z_O	$V_O = V_X$	12		55	Ω	1
Output High Voltage	V_{OH1}	$I_{OH} = -1 \text{ mA}$	2.4			V	1
Output Low Voltage	V_{OL1}	$I_{OL} = 1 \text{ mA}$			0.4	V	1
Output High Current	I_{OH1}	$V_{OH} = 2.0 \text{ V}$			-15	mA	1
Output Low Current	I_{OL1}	$V_{OL} = 0.8 \text{ V}$	10			mA	1
Edge Rate	t_{slewrf}	Rise/Fall edge rate between 20% 60%	1		4	V/ns	1
Rise Time	t_r	$V_{OL} = 0.4 \text{ V}, V_{OH} = 2.4 \text{ V}$	0.5		2	ns	1
Fall Time	t_f	$V_{OH} = 2.4 \text{ V}, V_{OL} = 0.4 \text{ V}$	0.5		2	ns	1
Duty Cycle	d_{T1}	$V_T = 50\%$	45		55	%	1
Group Skew	t_{skew}	$V_T = 1.5 \text{ V}$			150	ps	1
Jitter, Cycle-to-cycle	$t_{j\text{cyc-cyc}2B}$	$V_T = 1.5 \text{ V}$			250	ps	1

*TA = 0 - 70°C; Supply Voltage VDD = 3.3 V +/-5%

¹Guaranteed by design and characterization, not 100% tested in production.



Electrical Characteristics - REF-14.318MHz

PARAMETER	SYMBOL	CONDITIONS	MIN	TYP	MAX	UNITS	Notes
Long Accuracy	ppm	see Tperiod min-max values	-300		300	ppm	1,2
Clock period	T _{period}	14.318MHz output nominal	69.8270		69.8550	ns	2
Output High Voltage	V _{OH}	I _{OH} = -1 mA	2.4			V	1
Output Low Voltage	V _{OL}	I _{OL} = 1 mA			0.4	V	1
Output High Current	I _{OH}	V _{OH} @MIN = 1.0 V, V _{OH} @MAX = 3.135 V	-29		-23	mA	1
Output Low Current	I _{OL}	V _{OL} @MIN = 1.95 V, V _{OL} @MAX = 0.4 V	29		27	mA	1
Edge Rate	t _{slewr/f}	Rising/Falling edge rate	1		4	V/ns	1
Rise Time	t _{r1}	V _{OL} = 0.4 V, V _{OH} = 2.4 V	1		2	ns	1
Fall Time	t _{f1}	V _{OH} = 2.4 V, V _{OL} = 0.4 V	1		2	ns	1
Skew	t _{sk1}	V _T = 1.5 V			500	ps	1
Duty Cycle	d _{t1}	V _T = 1.5 V	45		55	%	1
Jitter	t _{jyc-cyc}	V _T = 1.5 V			1000	ps	1

*TA = 0 - 70°C; Supply Voltage VDD = 3.3 V +/-5%, CL = 20 pF with Rs = 7Ω (Rs is used in USB48MHz test only)

¹Guaranteed by design and characterization, not 100% tested in production.

²All Long Term Accuracy and Clock Period specifications are guaranteed assuming that REFOUT is at 14.31818MHz



Shared Pin Operation - Input/Output Pins

The I/O pins designated by (input/output) on the ICS950410 serve as dual signal functions to the device. During initial power-up, they act as input pins. The logic level (voltage) that is present on these pins at this time is read and stored into a 5-bit internal data latch. At the end of Power-On reset, (see AC characteristics for timing values), the device changes the mode of operations for these pins to an output function. In this mode the pins produce the specified buffered clocks to external loads.

To program (load) the internal configuration register for these pins, a resistor is connected to either the VDD (logic 1) power supply or the GND (logic 0) voltage potential. A 10 Kilohm (10K) resistor is used to provide both the solid CMOS programming voltage needed during the power-up programming period and to provide an insignificant load on the output clock during the subsequent operating period.

Figure 1 shows a means of implementing this function when a switch or 2 pin header is used. With no jumper is installed the pin will be pulled high. With the jumper in place the pin will be pulled low. If programmability is not necessary, than only a single resistor is necessary. The programming resistors should be located close to the series termination resistor to minimize the current loop area. It is more important to locate the series termination resistor close to the driver than the programming resistor.

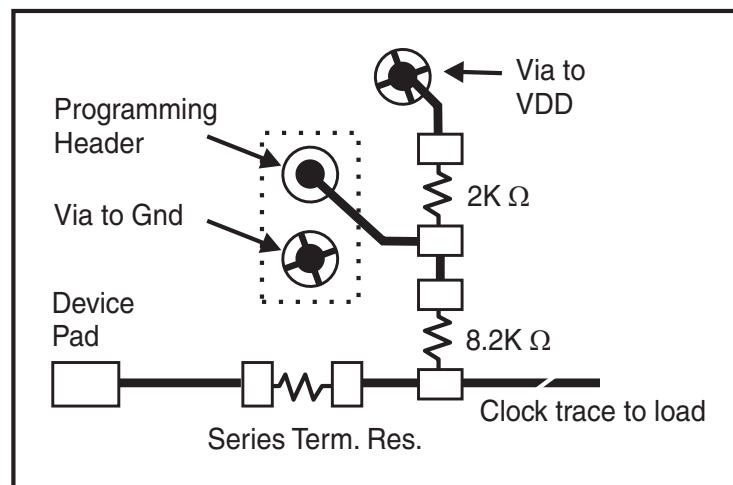
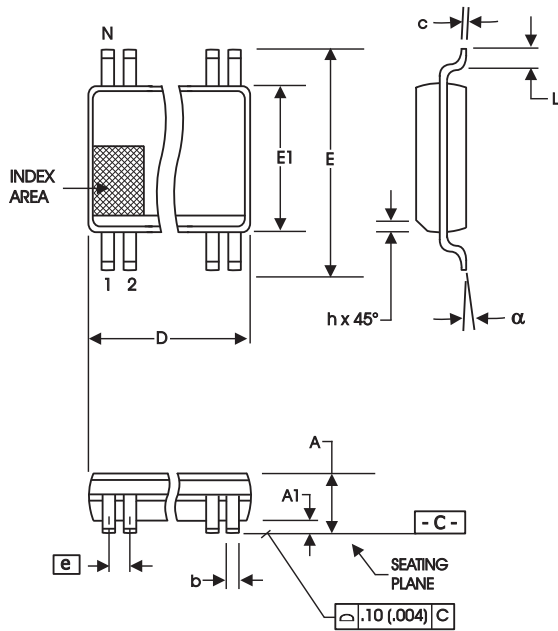

Fig. 1



300 mil SSOP Package

SYMBOL	In Millimeters COMMON DIMENSIONS		In Inches COMMON DIMENSIONS	
	MIN	MAX	MIN	MAX
A	2.41	2.80	.095	.110
A1	0.20	0.40	.008	.016
b	0.20	0.34	.008	.0135
c	0.13	0.25	.005	.010
D	SEE VARIATIONS		SEE VARIATIONS	
E	10.03	10.68	.395	.420
E1	7.40	7.60	.291	.299
e	0.635 BASIC		0.025 BASIC	
h	0.38	0.64	.015	.025
L	0.50	1.02	.020	.040
N	SEE VARIATIONS		SEE VARIATIONS	
alpha	0°	8°	0°	8°

N	VARIATIONS			
	D mm.		D (inch)	
	MIN	MAX	MIN	MAX
48	15.75	16.00	.620	.630

Reference Doc.: JEDEC Publication 95, MO-118
10-0034

Ordering Information

ICS950410yFLF-T

Example:

ICS XXXX y F LF-T

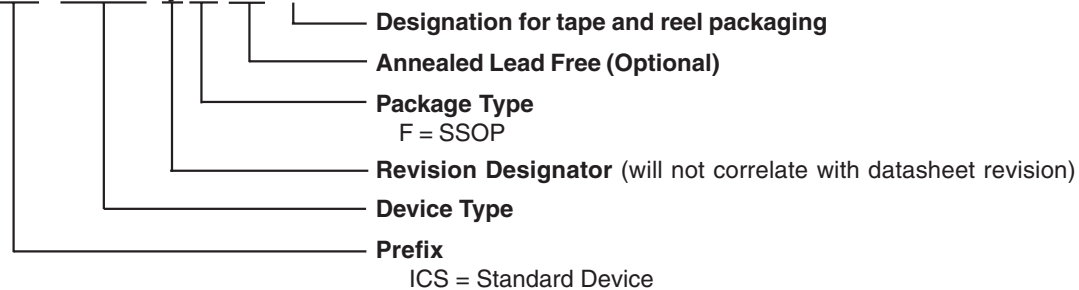

ICS950410

Preliminary Product Preview



Revision History

Rev.	Issue Date	Description	Page #
A	4/22/2005	1. Updated Byte 11/12 M/N programming description 2. Updated Ordering Information from "Lead Free" to Annealed Lead Free". 3. Preliminary Release.	8-9,15