

Programmable Timing Control Hub™ for P4™

Recommended Application:

CK-408 clock for Intel® 845 chipset.

Output Features:

- 3 - Pairs of differential CPU clocks @ 3.3V
- 3 - 3V66 @ 3.3V
- 9 - PCI @ 3.3V
- 2 - 48MHz @ 3.3V fixed
- 1 - 24_48MHz @ 3.3V, 48MHz, 24MHz or 66MHz
- 1 - REF @ 3.3V, 14.318MHz

Features/Benefits:

- Programmable output frequency.
- Programmable output divider ratios.
- Programmable output rise/fall time.
- Programmable output skew.
- Programmable spread percentage for EMI control.
- Watchdog timer technology to reset system if system malfunctions.
- Programmable watch dog safe frequency.
- Support I²C Index read/write and block read/write operations.
- Uses external 14.318MHz crystal.

Key Specifications:

- CPU Output Jitter <150ps
- 3V66 Output Jitter <250ps
- CPU Output Skew <100ps

Block Diagram

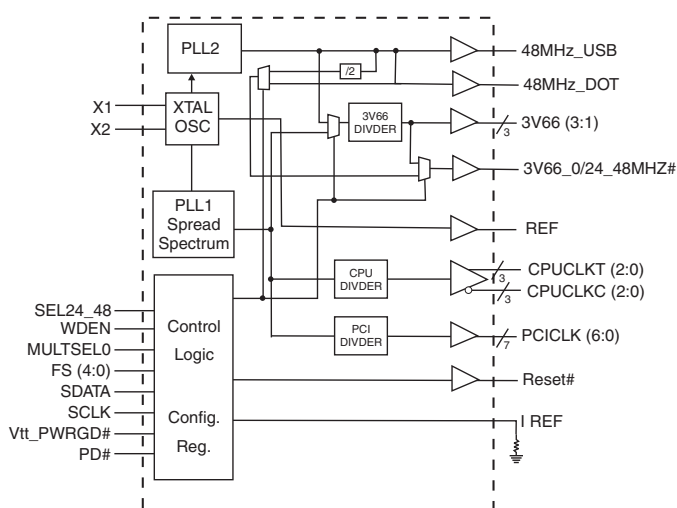

Pin Configuration

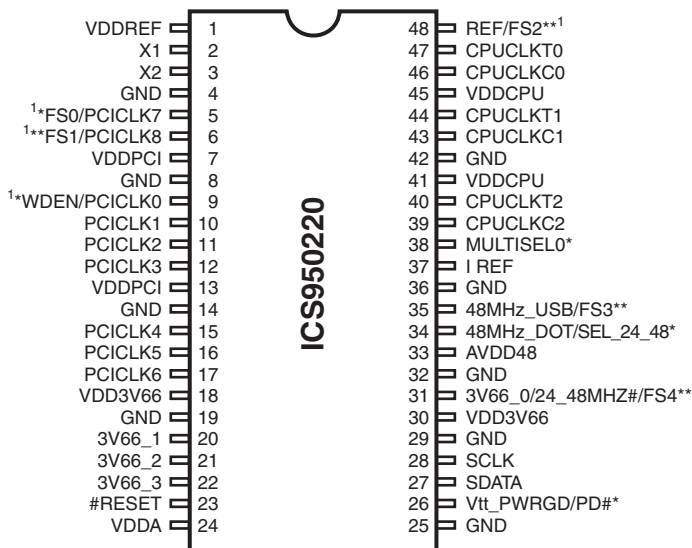

48-Pin 300-mil SSOP

1. These outputs have 2X drive strength.

* Internal Pull-up resistor of 120K to VDD

** these inputs have 120K internal pull-down to GND

Frequency Table

FS4	FS3	FS2	FS1	FS0	CPUCLK MHz	3V66 MHz	PCICLK MHz
0	0	0	0	1	100.00	66.67	33.33
1	0	0	0	1	133.33	66.67	33.33
1	1	1	1	0	66.67	66.67	33.34
1	1	1	1	1	200.00	66.67	33.33

For additional frequency selections please refer to Byte 0.

Power Groups

VDDA = Analog Core PLL

VDDREF = REF, Xtal

AVDD48 = 48MHz

General Description

The **ICS950220** is a single chip clock solution for desktop designs using the Intel 845 chipset with PC133 or DDR memory. It provides all necessary clock signals for such a system.

The **ICS950220** is part of a whole new line of ICS clock generators and buffers called TCH™ (Timing Control Hub). This part incorporates ICS's newest clock technology which offers more robust features and functionality. Employing the use of a serially programmable I²C interface, this device can adjust the output clocks by configuring the frequency setting, the output divider ratios, selecting the ideal spread percentage, the output skew, the output strength, and enabling/disabling each individual output clock. M/N control can configure output frequency with resolution up to 0.1MHz increment.

Pin Description

PIN NUMBER	PIN NAME	TYPE	DESCRIPTION
1, 7, 13, 18, 30, 41, 45	VDD	PWR	3.3V power supply.
2	X1	IN	Crystal input, has internal load cap (33pF) and feedback resistor from X2.
3	X2	OUT	Crystal output, nominally 14.318MHz. Has internal load cap (33pF).
4, 8, 14, 19, 25, 29, 32, 36, 42	GND	PWR	Ground pins for 3.3V supply.
22, 21, 20	3V66 (3:1)	OUT	3.3V Fixed 66MHz clock outputs for HUB.
5	PCICLK7	OUT	3.3V PCI clock output
	FS0	IN	Logic input frequency select bit. Input latched at power on.
6	PCICLK8	OUT	3.3V PCI clock output.
	FS1	IN	Logic input frequency select bit. Input latched at power on.
9	WDEN	IN	Hardware enable of watch dog circuit. Enabled when latched high.
	PCICLK0	OUT	3.3V PCI clock output.
17, 16, 15, 12, 11, 10	PCICLK (6:1)	OUT	3.3V PCI clock outputs.
23	RESET#	OUT	Real time system reset signal for frequency value or watchdog timer timeout. This signal is active low.
24	VDDA	PWR	Analog power 3.3V.
26	Vtt_PWRGD	IN	This 3.3V LVTTTL input is a level sensitive strobe used to determine when FS (4:0) inputs are valid and are ready to be sampled (active high).
	PD#	IN	Asynchronous active low input pin used to power down the device into a low power state. The internal clocks are disabled and the VCO and the crystal are stopped. The latency of the power down will not be greater than 3ms.
28	SCLK	IN	Clock pin for I ² C circuitry 5V tolerant.
27	SDATA	I/O	Data pin for I ² C circuitry 5V tolerant.
31	3V66_0/24_48MHZ#	OUT	3.3V output selectable through I ² C to be 66MHz from internal VCO or 48MHz/24MHz.
	FS4	IN	Logic input frequency select bit. Input latched at power on.
33	AVDD48	PWR	Analog power 3.3V.
34	48MHz_DOT	OUT	3.3V Fixed 48MHz clock output for DOT.
	SEL24_48	IN	This selects the frequency for the SEL24_48 output. High = 24MHz, Low = 48MHz.
35	FS3	IN	Logic input frequency select bit. Input latched at power on.
	48MHz_USB	OUT	3.3V Fixed 48MHz clock output for USB.
37	I REF	OUT	This pin establishes the reference current for the CPUCLK pairs. This pin requires a fixed precision resistor tied to ground in order to establish the appropriate current.
38	MULTSELO	IN	3.3V LVTTTL input for selecting the current multiplier for CPU outputs
39, 43, 46	CPUCLKC (2:0)	OUT	"Complementary" clocks of differential pair CPU outputs. These are current outputs and external resistors are required for voltage bias.
40, 44, 47	CPUCLKT (2:0)	OUT	"True" clocks of differential pair CPU outputs. These are current outputs and external resistors are required for voltage bias.
48	FS2	IN	Logic input frequency select bit. Input latched at power on.
	REF	OUT	3.3V, 14.318MHz reference clock output.



Maximum Allowed Current

Condition	Max 3.3V supply consumption Max discrete cap loads, Vdd = 3.465V All static inputs = Vdd or GND
Powerdown Mode (PWRDWN# = 0)	40mA
Full Active	360mA

Host Swing Select Functions

MULTISELO	Board Target Trace/Term Z	Reference R, Iref = $V_{DD}/(3 \cdot R_r)$	Output Current	Voh @ Z
0	50 ohms	Rr = 221 1%, Iref = 5.00mA	Ioh = 4 * I REF	1.0V @ 50
1	50 ohms	Rr = 475 1%, Iref = 2.32mA	Ioh = 6 * I REF	0.7V @ 50

General SMBus serial interface information

How to Write:

- Controller (host) sends a start bit.
- Controller (host) sends the write address $D2_{(H)}$
- ICS clock will **acknowledge**
- Controller (host) sends the beginning byte location = N
- ICS clock will **acknowledge**
- Controller (host) sends the data byte count = X
- ICS clock will **acknowledge**
- Controller (host) starts sending **Byte N through Byte N + X - 1**
- ICS clock will **acknowledge** each byte **one at a time**
- Controller (host) sends a Stop bit

How to Read:

- Controller (host) will send start bit.
- Controller (host) sends the write address $D2_{(H)}$
- ICS clock will **acknowledge**
- Controller (host) sends the beginning byte location = N
- ICS clock will **acknowledge**
- Controller (host) will send a separate start bit.
- Controller (host) sends the read address $D3_{(H)}$
- ICS clock will **acknowledge**
- ICS clock will send the data byte count = X
- ICS clock sends **Byte N + X - 1**
- ICS clock sends **Byte 0 through byte X (if $X_{(H)}$ was written to byte 8).**
- Controller (host) will need to acknowledge each byte
- Controller (host) will send a not acknowledge bit
- Controller (host) will send a stop bit

Index Block Write Operation		
Controller (Host)		ICS (Slave/Receiver)
T	starT bit	
Slave Address $D2_{(H)}$		
WR	WRite	
		ACK
Beginning Byte = N		
		ACK
Data Byte Count = X		
		ACK
Beginning Byte N		X Byte
○		
○		
○		
Byte N + X - 1		
		ACK
P	stoP bit	

Index Block Read Operation		
Controller (Host)		ICS (Slave/Receiver)
T	starT bit	
Slave Address $D2_{(H)}$		
WR	WRite	
		ACK
Beginning Byte = N		
		ACK
RT	Repeat starT	
Slave Address $D3_{(H)}$		
RD	ReaD	
		ACK
		Data Byte Count = X
ACK		X Byte
ACK		
○		
○		
○		
		Byte N + X - 1
N	Not acknowledge	
P	stoP bit	

Byte 0: Functionality and frequency select register (Default=0)

Bit	Description									PWD
Bit (2,7:4)	Bit2	Bit7	Bit6	Bit5	Bit4	CPUCLK MHz	3V66 MHz	PCICLK MHz	Spread %	Note 1
	FS4	FS3	FS2	FS1	FS0					
	0	0	0	0	0	100.90	67.27	33.63	+/-0.35% center spread	
	0	0	0	0	1	100.00	66.67	33.33	0 to -0.6% down spread	
	0	0	0	1	0	103.00	68.67	34.33	+/-0.35% center spread	
	0	0	0	1	1	105.00	70.00	35.00	+/-0.35% center spread	
	0	0	1	0	0	107.00	71.33	35.67	+/-0.35% center spread	
	0	0	1	0	1	109.00	72.67	36.33	+/-0.35% center spread	
	0	0	1	1	0	111.00	74.00	37.00	+/-0.35% center spread	
	0	0	1	1	1	114.00	76.00	38.00	+/-0.35% center spread	
	0	1	0	0	0	117.00	78.00	39.00	+/-0.35% center spread	
	0	1	0	0	1	120.00	80.00	40.00	+/-0.35% center spread	
	0	1	0	1	0	127.00	84.67	42.33	+/-0.35% center spread	
	0	1	0	1	1	130.00	86.67	43.33	+/-0.35% center spread	
	0	1	1	0	0	133.33	88.89	44.44	+/-0.35% center spread	
	0	1	1	0	1	170.00	56.67	28.33	+/-0.35% center spread	
	0	1	1	1	0	180.00	60.00	30.00	+/-0.35% center spread	
	0	1	1	1	1	190.00	63.33	31.67	+/-0.35% center spread	
	1	0	0	0	0	133.90	66.95	33.48	+/-0.35% center spread	
	1	0	0	0	1	133.33	66.67	33.33	0 to -0.6% down spread	
	1	0	0	1	0	120.00	60.00	30.00	+/-0.35% center spread	
	1	0	0	1	1	125.00	62.50	31.25	+/-0.35% center spread	
	1	0	1	0	0	134.90	67.45	33.73	+/-0.35% center spread	
	1	0	1	0	1	137.00	68.50	34.25	+/-0.35% center spread	
	1	0	1	1	0	139.00	69.50	34.75	+/-0.35% center spread	
	1	0	1	1	1	141.00	70.50	35.25	+/-0.35% center spread	
	1	1	0	0	0	143.00	71.50	35.75	+/-0.35% center spread	
	1	1	0	0	1	145.00	72.50	36.25	+/-0.35% center spread	
	1	1	0	1	0	150.00	75.00	37.5	+/-0.35% center spread	
	1	1	0	1	1	155.00	77.50	38.75	+/-0.35% center spread	
1	1	1	0	0	160.00	80.00	40.00	+/-0.35% center spread		
1	1	1	0	1	170.00	85.00	42.50	+/-0.35% center spread		
1	1	1	1	0	66.67	66.67	33.34	0 to -0.6% down spread		
1	1	1	1	1	200.00	66.67	33.33	0 to -0.6% down spread		
Bit 3	0 - Frequency is selected by hardware select, latched inputs 1 - Frequency is selected by Bit 2,7:4									0
Bit 1	0 - Normal 1 - Spread spectrum enable									1
Bit 0	0 - Watch dog safe frequency will be selected by latch inputs 1 - Watch dog safe frequency will be programmed by Byte 10 bit (4:0)									0

Notes:

1. Default at power-up will be for latched logic inputs to define frequency, as displayed by Bit 3.

Byte 1: Output Control Register
(1 = enable, 0 = disable)

Bit	Pin#	PWD	Description
Bit7	40, 39	1	CPUT/C2
Bit6	44, 43	1	CPUT/C1
Bit5	47, 46	1	CPUT/C0
Bit4	-	X	FS4 Read back
Bit3	-	X	FS3 Read back
Bit2	-	X	FS2 Read back
Bit1	-	X	FS1 Read back
Bit0	-	X	FS0 Read back

Byte 2: Output Control Register
(1 = enable, 0 = disable)

Bit	Pin#	PWD	Description
Bit7	-	X	MULTSEL (Read back)
Bit6	17	1	PCICLK_6
Bit5	16	1	PCICLK_5
Bit4	15	1	PCICLK_4
Bit3	12	1	PCICLK_3
Bit2	11	1	PCICLK_2
Bit1	10	1	PCICLK_1
Bit0	9	1	PCICLK_0

Byte 3: Output Control Register
(1 = enable, 0 = disable)

Bit	Pin#	PWD	Description
Bit7	34	1	48MHZ_DOT
Bit6	35	1	48MHz_USB
Bit5	-	1	Reset gear shift detect 1 = Enable, 0 = Disable
Bit4	-	X	Reserved
Bit3	31	0	3V66_0/24_48MHZ#, (default) 1 = 66.66MHz, 0 = 24_48MHZ#
Bit2	-	X	Reserved
Bit1	6	1	PCICLK8
Bit0	5	1	PCICLK7

Byte 4: Output Control Register
(1 = enable, 0 = disable)

Bit	Pin#	PWD	Description
Bit 7	-	1	Async. 3V66 control bit 0 : 3V66 / PCI = 64/32 MHz asynchronous with CPU 1 : 3V66 / PCI = 66.6/33.3 MHz synchronous with CPU
Bit 6	-	X	Reserved
Bit 5	-	X	Reserved
Bit 4	31	1	3V66_0/24_48MHZ#
Bit 3	-	X	Reserved
Bit 2	22	1	3V66_3
Bit 1	21	1	3V66_2
Bit 0	20	1	3V66_1

Notes:

1. PWD = Power on Default
2. For disabled clocks, they stop low for single ended clocks. Differential CPU clocks stop with CPUCLKT at high, CPUCLKC off, and external resistor termination will bring CPUCLKC low.

Byte 5: Programming Edge Rate
(1 = enable, 0 = disable)

Bit	Pin#	PWD	Description
Bit 7	X	1	(Reserved)
Bit 6	X	1	(Reserved)
Bit 5	X	1	(Reserved)
Bit 4	X	1	(Reserved)
Bit 3	X	1	(Reserved)
Bit 2	X	1	(Reserved)
Bit 1	X	1	(Reserved)
Bit 0	X	1	(Reserved)

Byte 6: Vendor ID Register
(1 = enable, 0 = disable)

Bit	Name	PWD	Description
Bit 7	Revision ID Bit3	X	Revision ID values will be based on individual device's revision
Bit 6	Revision ID Bit2	X	
Bit 5	Revision ID Bit1	X	
Bit 4	Revision ID Bit0	X	
Bit 3	Vendor ID Bit3	0	(Reserved)
Bit 2	Vendor ID Bit2	0	(Reserved)
Bit 1	Vendor ID Bit1	0	(Reserved)
Bit 0	Vendor ID Bit0	1	(Reserved)

Byte 7: Revision ID and Device ID Register

Bit	Name	PWD	Description
Bit 7	Device ID7	0	Device ID values will be based on individual device "22H" in this case.
Bit 6	Device ID6	0	
Bit 5	Device ID5	1	
Bit 4	Device ID4	0	
Bit 3	Device ID3	0	
Bit 2	Device ID2	0	
Bit 1	Device ID1	1	
Bit 0	Device ID0	0	

Byte 8: Byte Count Read Back Register

Bit	Name	PWD	Description
Bit 7	Byte7	0	Note: Writing to this register will configure byte count and how many bytes will be read back, default is 0FH = 15 bytes.
Bit 6	Byte6	0	
Bit 5	Byte5	0	
Bit 4	Byte4	0	
Bit 3	Byte3	1	
Bit 2	Byte2	1	
Bit 1	Byte1	1	
Bit 0	Byte0	1	

Byte 9: Watchdog Timer Count Register

Bit	Name	PWD	Description
Bit 7	WD7	0	The decimal representation of these 8 bits correspond to X • 290ms the watchdog timer will wait before it goes to alarm mode and reset the frequency to the safe setting. Default at power up is 8 • 290ms = 2.3 seconds.
Bit 6	WD6	0	
Bit 5	WD5	0	
Bit 4	WD4	0	
Bit 3	WD3	1	
Bit 2	WD2	0	
Bit 1	WD1	0	
Bit 0	WD0	0	

Byte 10: Programming Enable bit 8 Watchdog Control Register

Bit	Name	PWD	Description
Bit 7	Program Enable	0	Programming Enable bit 0 = no programming. Frequencies are selected by HW latches or Byte0 1 = enable all PC programming.
Bit 6	WD Enable	1	Watchdog Enable bit. This bit will over write WDEN latched value. 0 = disable, 1 = Enable.
Bit 5	WD Alarm	1	Watchdog Alarm Status 0 = normal 1= alarm status
Bit 4	SF4	0	Watchdog safe frequency bits. Writing to these bits will configure the safe frequency corresponding to Byte 0 Bit 2, 7:4 table
Bit 3	SF3	0	
Bit 2	SF2	0	
Bit 1	SF1	0	
Bit 0	SF0	0	

Byte 11: VCO Frequency M Divider (Reference divider) Control Register

Bit	Name	PWD	Description
Bit 7	Ndiv 8	X	N divider bit 8
Bit 6	Mdiv 6	X	The decimal representation of Mdiv (6:0) correspond to the reference divider value. Default at power up is equal to the latched inputs selection.
Bit 5	Mdiv 5	X	
Bit 4	Mdiv 4	X	
Bit 3	Mdiv 3	X	
Bit 2	Mdiv 2	X	
Bit 1	Mdiv 1	X	
Bit 0	Mdiv 0	X	

Byte 12: VCO Frequency N Divider (VCO divider) Control Register

Bit	Name	PWD	Description
Bit 7	Ndiv 7	X	The decimal representation of Ndiv (8:0) correspond to the VCO divider value. Default at power up is equal to the latched inputs selection. Notice Ndiv 8 is located in Byte 11.
Bit 6	Ndiv 6	X	
Bit 5	Ndiv 5	X	
Bit 4	Ndiv 4	X	
Bit 3	Ndiv 3	X	
Bit 2	Ndiv 2	X	
Bit 1	Ndiv 1	X	
Bit 0	Ndiv 0	X	

Byte 13: Spread Spectrum Control Register

Bit	Name	PWD	Description
Bit 7	SS 7	X	The Spread Spectrum (12:0) bit will program the spread percentage. Spread percent needs to be calculated based on the VCO frequency, spreading profile, spreading amount and spread frequency. It is recommended to use ICS software for spread programming. Default power on is latched FS divider.
Bit 6	SS 6	X	
Bit 5	SS 5	X	
Bit 4	SS 4	X	
Bit 3	SS 3	X	
Bit 2	SS 2	X	
Bit 1	SS 1	X	
Bit 0	SS 0	X	

Byte 14: Spread Spectrum Control Register

Bit	Name	PWD	Description
Bit 7	Reserved	X	Reserved
Bit 6	Reserved	X	Reserved
Bit 5	Reserved	X	Reserved
Bit 4	SS 12	X	Spread Spectrum Bit 12
Bit 3	SS 11	X	Spread Spectrum Bit 11
Bit 2	SS 10	X	Spread Spectrum Bit 10
Bit 1	SS 9	X	Spread Spectrum Bit 9
Bit 0	SS 8	X	Spread Spectrum Bit 8

Byte 15: Output Divider Control Register

Bit	Name	PWD	Description
Bit 7	CPU Div 3	0	CPU 2 clock divider ratio can be configured via these 4 bits individually. For divider selection table refer to Table 1. Default at power up is latched FS divider.
Bit 6	CPU Div 2	1	
Bit 5	CPU Div 1	0	
Bit 4	CPU Div 0	0	
Bit 3	CPU Div 3	0	CPU (1:0) clock divider ratio can be configured via these 4 bits individually. For divider selection table refer to Table 1. Default at power up is latched FS divider.
Bit 2	CPU Div 2	1	
Bit 1	CPU Div 1	0	
Bit 0	CPU Div 0	0	

Byte 16: Output Divider Control Register

Bit	Name	PWD	Description
Bit 7	Div 3	0	3V66_0 clock divider ratio can be configured via these 4 bits individually. For divider selection table refer to Table 1. Default at power up is latched FS divider.
Bit 6	Div 2	1	
Bit 5	Div 1	0	
Bit 4	Div 0	1	
Bit 3	Div 3	0	3V66 (3:1) clock divider ratio can be configured via these 4 bits individually. For divider selection table refer to Table 1. Default at power up is latched FS divider.
Bit 2	Div 2	1	
Bit 1	Div 1	0	
Bit 0	Div 0	1	

Byte 17: Output Divider Control Register

Bit	Name	PWD	Description
Bit 7	3V66_INV	0	3V66_0 Phase Inversion bit
Bit 6	3V66_INV	0	3V66 (3:1) Phase Inversion bit
Bit 5	CPU_INV	0	CPU 2 Phase Inversion bit
Bit 4	CPU_INV	0	CPU (1:0) Phase Inversion bit
Bit 3	PCI Div 3	1	PCI clock divider ratio can be configured via these 4 bits individually. For divider selection table refer to Table 2. Default at power up is latched FS divider.
Bit 2	PCI Div 2	0	
Bit 1	PCI Div 1	0	
Bit 0	PCI Div 0	1	

Table 1

Div (3:2)	Div (1:0)			
	00	01	10	11
00	/2	/4	/8	/16
01	/3	/6	/12	/24
10	/5	/10	/20	/40
11	/7	/14	/28	/56

Table 2

Div (3:2)	Div (1:0)			
	00	01	10	11
00	/4	/8	/16	/32
01	/3	/6	/12	/24
10	/5	/10	/20	/40
11	/9	/18	/36	/72

Byte 18: Group Skew Control Register

Bit	Name	PWD	Description
Bit 7	CPU_Skew 1	0	These 2 bits delay the CPUCLKC/T2 with respect to CPUCLKC/T (1:0) 00 = 0ps 01 = 250ps 10 = 500ps 11 = 750ps
Bit 6	CPU_Skew 0	0	
Bit 5	Reserved	0	Reserved
Bit 4	Reserved	0	Reserved
Bit 3	CPU_Skew 1	0	These 2 bits delay the CPUCLKC/T (1:0) clock with respect to CPUCLKC/T2 00 = 0ps 01 = 250ps 10 = 500ps 11 = 750ps
Bit 2	CPU_Skew 0	0	
Bit 1	Reserved	0	Reserved
Bit 0	Reserved	0	Reserved

Byte 19: Group Skew Control Register

Bit	Name	PWD	Description
Bit 7	3V66_Skew 1	0	These 2 bits delay the 3V66 (3:1) with respect to CPUCLK 00 = 0ps 01 = 250ps 10 = 500ps 11 = 750ps
Bit 6	3V66_Skew 0	0	
Bit 5	Reserved	0	Reserved
Bit 4	Reserved	0	Reserved
Bit 3	3V66_Skew 1	0	These 2 bits delay the 3V66_0 with respect to CPUCLK 00 = 0ps 01 = 250ps 10 = 500ps 11 = 750ps
Bit 2	3V66_Skew 0	0	
Bit 1	Reserved	0	Reserved
Bit 0	Reserved	0	Reserved

Byte 20: Group Skew Control Register

Bit	Name	PWD	Description
Bit 7	PCI_Skew 3	1	These 4 bits can change the CPU to PCI (6:0) skew from -0.3ns 1.2ns. Default at power up is 0.5ns. Each binary increment or decrement of Bits (3:0) will increase or decrease the delay of the PCI clocks by 100ps.
Bit 6	PCI_Skew 2	0	
Bit 5	PCI_Skew 1	0	
Bit 4	PCI_Skew 0	0	
Bit 3	PCI_Skew 3	1	These 4 bits can change the CPU to PCI (8:7) skew from -0.6ns 1.2ns. Default at power up is 0.4ns. Each binary increment or decrement of Bit (3:0) will increase or decrease the delay of the PCI clocks by 100ps.
Bit 2	PCI_Skew 2	0	
Bit 1	PCI_Skew 1	0	
Bit 0	PCI_Skew 0	0	

Byte 21: Slew Rate Control Register

Bit	Name	PWD	Description
Bit 7	Reserved	1	Reserved
Bit 6	Reserved	0	Reserved
Bit 5	PCIF Slew 1	1	PCIF(1:0) clock slew rate control bits. 01 = strong; 11 = normal; 10 = weak
Bit 4	PCIF Slew 0	0	
Bit 3	3V66 (3:1) Slew 1	1	3V66 (3:1) clock slew rate control bits. 01 = strong; 11 = normal; 10 = weak
Bit 2	3V66 (3:1) Slew 1	0	
Bit 1	3V66_0 Slew 1	1	3V66_0 clock slew rate control bits. 01 = strong; 11 = normal; 10 = weak
Bit 0	3V66_0 Slew 0	0	

Byte 22: Slew Rate Control Register

Bit	Name	PWD	Description
Bit 7	REF Slew 1	1	REF clock slew rate control bits. 01 = strong; 11 = normal; 10 = weak
Bit 6	REF Slew 0	0	
Bit 5	PCI (6:4) Slew 1	1	PCI (6:4) clock slew rate control bits. 01 = strong; 11 = normal; 10 = weak
Bit 4	PCI (6:4) Slew 0	0	
Bit 3	PCI (3:1) Slew 1	1	PCI (3:1) clock slew rate control bits. 01 = strong; 11 = normal; 10 = weak
Bit 2	PCI (3:1) Slew 0	0	
Bit 1	PCI0 Slew 1	1	PCI0 clock slew rate control bits. 01 = strong; 11 = normal; 10 = weak
Bit 0	PCI0 Slew 0	0	

Byte 23: Slew Rate Control Register

Bit	Name	PWD	Description
Bit 7	Reserved	X	Reserved
Bit 6	Reserved	X	
Bit 5	VCH Slew 1	1	VCH clock slew rate control bits. 01 = strong; 11 = normal; 10 = weak
Bit 4	VCH Slew 0	0	
Bit 3	48USB Slew 1	1	48USB clock slew rate control bits. 01 = strong; 11 = normal; 10 = weak
Bit 2	48USB Slew 0	0	
Bit 1	48DOT Slew 1	1	48DOT clock slew rate control bits. 01 = strong; 11 = normal; 10 = weak
Bit 0	48DOT Slew 0	0	

Absolute Maximum Ratings

Supply Voltage	5.5 V
Logic Inputs	GND -0.5 V to $V_{DD} + 0.5$ V
Ambient Operating Temperature	0°C to +70°C
Case Temperature	115°C
Storage Temperature	-65°C to +150°C

Stresses above those listed under *Absolute Maximum Ratings* may cause permanent damage to the device. These ratings are stress specifications only and functional operation of the device at these or any other conditions above those listed in the operational sections of the specifications is not implied. Exposure to absolute maximum rating conditions for extended periods may affect product reliability.

Electrical Characteristics - Input/Supply/Common Output Parameters

$T_A = 0 - 70^\circ\text{C}$; Supply Voltage $V_{DD} = 3.3$ V +/-5%

PARAMETER	SYMBOL	CONDITIONS	MIN	TYP	MAX	UNITS
Input High Voltage	V_{IH}		2		$V_{DD} + 0.3$	V
Input Low Voltage	V_{IL}		$V_{SS} - 0.3$		0.8	V
Input High Current	I_{IH}	$V_{IN} = V_{DD}$	-5		5	mA
Input Low Current	I_{IL1}	$V_{IN} = 0$ V; Inputs with no pull-up resistors	-5			mA
	I_{IL2}	$V_{IN} = 0$ V; Inputs with pull-up resistors	-200			
Operating Supply Current	$I_{DD3.3OP}$	$C_L = \text{Full load}$	229	221	360	mA
Powerdown Current	$I_{DD3.3PD}$	IREF=2.32 mA		21	25	mA
Input Frequency	F_i	$V_{DD} = 3.3$ V		14.318		MHz
Pin Inductance	L_{pin}				7	nH
Input Capacitance ¹	C_{IN}	Logic Inputs			5	pF
	C_{OUT}	Output pin capacitance			6	pF
	C_{INX}	X1 & X2 pins	27		45	pF
Transition time ¹	T_{trans}	To 1st crossing of target frequency			3	ms
Settling time ¹	T_s	From 1st crossing to 1% target frequency			3	ms
Clk Stabilization ¹	T_{STAB}	From $V_{DD} = 3.3$ V to 1% target frequency			3	ms
Delay ¹	t_{PZH}, t_{PZL}	Output enable delay (all outputs)	1		10	ns
	t_{PHZ}, t_{PLZ}	Output disable delay (all outputs)	1		10	ns
3V66 to PCI	$S_{3V66-PCI}$	3V66 (5:0) leads 33MHz PCI	1.5	2.12	3.5	ns

¹Guaranteed by design, not 100% tested in production.

Electrical Characteristics - CPU 0.7V Current Mode Differential Pair
 $T_A = 0 - 70^\circ\text{C}$; $V_{DD} = 3.3\text{ V} \pm 5\%$; $C_L = 2\text{pF}$

PARAMETER	SYMBOL	CONDITIONS	MIN	TYP	MAX	UNITS	NOTES
Current Source Output Impedance	Z_o^1	$V_o = V_x$	3000			Ω	1
Voltage High	VHigh	Statistical measurement on single ended signal using oscilloscope math function.	660	770	850	mV	1
Voltage Low	VLow		-150	5	150		1
Max Voltage	Vovs	Measurement on single ended signal using absolute value.		756	1150	mV	1
Min Voltage	Vuds		-300	-7			1
Crossing Voltage (abs)	Vcross(abs)		250	350	550	mV	1
Crossing Voltage (var)	d-Vcross	Variation of crossing over all edges		12	140	mV	1
Long Accuracy	ppm	see Tperiod min-max values	-300		300	ppm	1,2
Average period	Tperiod	200MHz nominal	4.9985		5.0015	ns	2
		200MHz spread	4.9985		5.0266	ns	2
		166.66MHz nominal	5.9982		6.0018	ns	2
		166.66MHz spread	5.9982		6.0320	ns	2
		133.33MHz nominal	7.4978		7.5023	ns	2
		133.33MHz spread	7.4978		5.4000	ns	2
		100.00MHz nominal	9.9970		10.0030	ns	2
		100.00MHz spread	9.9970		10.0533	ns	2
Absolute min period	T_{absmin}	200MHz nominal	4.8735			ns	1,2
		166.66MHz nominal/spread	5.8732			ns	1,2
		133.33MHz nominal/spread	7.3728			ns	1,2
		100.00MHz nominal/spread	9.8720			ns	1,2
Rise Time	t_r	$V_{OL} = 0.175\text{V}$, $V_{OH} = 0.525\text{V}$	175	332	700	ps	1
Fall Time	t_f	$V_{OH} = 0.525\text{V}$ $V_{OL} = 0.175\text{V}$	175	344	700	ps	1
Rise Time Variation	d- t_r			30	125	ps	1
Fall Time Variation	d- t_f			30	125	ps	1
Duty Cycle	d_{t3}	Measurement from differential waveform	45	49	55	%	1
Skew	t_{sk3}	$V_T = 50\%$		8	150	ps	1
Jitter, Cycle to cycle	$t_{j\text{cyc-cyc}}$	Measurement from differential waveform		60	150	ps	1

¹Guaranteed by design, not 100% tested in production.

²All Long Term Accuracy and Clock Period specifications are guaranteed with the assumption that Ref output is at 14.31818MHz

Electrical Characteristics - PCICLK

$T_A = 0 - 70^\circ\text{C}$; $V_{DD} = 3.3\text{V} \pm 5\%$; $C_L = 10\text{-}30\text{ pF}$ (unless otherwise specified)

PARAMETER	SYMBOL	CONDITIONS	MIN	TYP	MAX	UNITS
Output Frequency	F_{O1}			33.33		MHz
Output Impedance	R_{DSP1}^1	$V_O = V_{DD} * (0.5)$	12		55	Ω
Output High Voltage	V_{OH}^1	$I_{OH} = -1\text{ mA}$	2.4			V
Output Low Voltage	V_{OL}^1	$I_{OL} = 1\text{ mA}$			0.55	V
Output High Current	I_{OH}^1	$V_{OH@MIN} = 1.0\text{ V}$, $V_{OH@MAX} = 3.135\text{ V}$	-33		-33	mA
Output Low Current	I_{OL}^1	$V_{OL@MIN} = 1.95\text{ V}$, $V_{OL@MAX} = 0.4\text{ V}$	30		38	mA
Rise Time	t_{r1}^1	$V_{OL} = 0.4\text{ V}$, $V_{OH} = 2.4\text{ V}$	0.5	188	2	ns
Fall Time	t_{f1}^1	$V_{OH} = 2.4\text{ V}$, $V_{OL} = 0.4\text{ V}$	0.5	1.79	2	ns
Duty Cycle	d_{t1}^1	$V_T = 1.5\text{ V}$	45	52	55	%
Skew	t_{sk1}^1	$V_T = 1.5\text{ V}$		280	500	ps
Jitter, cycle to cyc	$t_{jvc-cyc}^1$	$V_T = 1.5\text{ V}$		200	500	ps

¹Guaranteed by design, not 100% tested in production.

Electrical Characteristics - 3V66

$T_A = 0 - 70^\circ\text{C}$; $V_{DD} = 3.3\text{V} \pm 5\%$; $C_L = 10\text{-}30\text{ pF}$ (unless otherwise specified)

PARAMETER	SYMBOL	CONDITIONS	MIN	TYP	MAX	UNITS
Output Frequency	F_{O1}					MHz
Output Impedance	R_{DSP1}^1	$V_O = V_{DD} * (0.5)$	12	33	55	Ω
Output High Voltage	V_{OH}^1	$I_{OH} = -1\text{ mA}$	2.4			V
Output Low Voltage	V_{OL}^1	$I_{OL} = 1\text{ mA}$			0.55	V
Output High Current	I_{OH}^1	$V_{OH@MIN} = 1.0\text{ V}$, $V_{OH@MAX} = 3.135\text{ V}$	-33		-33	mA
Output Low Current	I_{OL}^1	$V_{OL@MIN} = 1.95\text{ V}$, $V_{OL@MAX} = 0.4\text{ V}$	30		38	mA
Rise Time	t_{r1}^1	$V_{OL} = 0.4\text{ V}$, $V_{OH} = 2.4\text{ V}$	0.5	1.55	2	ns
Fall Time	t_{f1}^1	$V_{OH} = 2.4\text{ V}$, $V_{OL} = 0.4\text{ V}$	0.5	1.32	2	ns
Duty Cycle	d_{t1}^1	$V_T = 1.5\text{ V}$	45	51.7	55	%
Skew	t_{sk1}^1	$V_T = 1.5\text{ V}$		16	250	ps
Jitter	$t_{jvc-cyc}^1$	$V_T = 1.5\text{ V}$		200	250	ps

¹Guaranteed by design, not 100% tested in production.

Note: 3V66@66Mhz- main PLL

Electrical Characteristics - VCH, 48MHz DOT, 48MHz, USB
 $T_A = 0 - 70^\circ\text{C}$; $V_{DD} = 3.3\text{V} \pm 5\%$; $C_L = 10\text{-}20\text{ pF}$ (unless otherwise specified)

PARAMETER	SYMBOL	CONDITIONS	MIN	TYP	MAX	UNITS
Output Frequency	F_{O1}	$V_O = V_{DD}^*(0.5)$		48		MHz
Output Impedance	R_{DSP1}^1	$V_O = V_{DD}^*(0.5)$	12		55	Ω
Output High Voltage	V_{OH}^1	$I_{OH} = -1\text{ mA}$	2.4	3.1		V
Output Low Voltage	V_{OL}^1	$I_{OL} = 1\text{ mA}$		0.19	0.55	V
Output High Current	I_{OH}^1	$V_{OH@MIN} = 1.0\text{ V}$, $V_{OH@MAX} = 3.135\text{ V}$	-29		-23	mA
Output Low Current	I_{OL}^1	$V_{OL@MIN} = 1.95\text{ V}$, $V_{OL@MAX} = 0.4\text{ V}$	29		27	mA
48DOT Rise Time	t_{r1}^1	$V_{OL} = 0.4\text{ V}$, $V_{OH} = 2.4\text{ V}$	0.5	0.77	1	ns
48DOT Fall Time	t_{f1}^1	$V_{OH} = 2.4\text{ V}$, $V_{OL} = 0.4\text{ V}$	0.5	0.84	1	ns
VCH 48 USB Rise Time	t_{r1}^1	$V_{OL} = 0.4\text{ V}$, $V_{OH} = 2.4\text{ V}$	1	1.12	2	ns
VCH 48 USB Fall Time	t_{f1}^1	$V_{OH} = 2.4\text{ V}$, $V_{OL} = 0.4\text{ V}$	1	1.42	2	ns
48DOTDuty Cycle	d_{t1}^1	$V_T = 1.5\text{ V}$	45	49.9	55	%
48 USB Duty Cycle	d_{t1}^1	$V_T = 1.5\text{ V}$	45	54.9	55	%
Jitter	$t_{jvc-cvc}^1$	$V_T = 1.5\text{ V}$		131	350	ps

¹Guaranteed by design, not 100% tested in production.

Electrical Characteristics - REF
 $T_A = 0 - 70^\circ\text{C}$; $V_{DD} = 3.3\text{V} \pm 5\%$; $C_L = 10\text{-}20\text{ pF}$ (unless otherwise specified)

PARAMETER	SYMBOL	CONDITIONS	MIN	TYP	MAX	UNITS
Output Frequency	F_{O1}			14.31		MHz
Output Impedance	R_{DSP1}^1	$V_O = V_{DD}^*(0.5)$	20		60	Ω
Output High Voltage	V_{OH}^1	$I_{OH} = -1\text{ mA}$	2.4			V
Output Low Voltage	V_{OL}^1	$I_{OL} = 1\text{ mA}$			0.4	V
Output High Current	I_{OH}^1	$V_{OH@MIN} = 1.0\text{ V}$, $V_{OH@MAX} = 3.135\text{ V}$	-29		-23	mA
Output Low Current	I_{OL}^1	$V_{OL@MIN} = 1.95\text{ V}$, $V_{OL@MAX} = 0.4\text{ V}$	29		27	mA
Rise Time	t_{r1}^1	$V_{OL} = 0.4\text{ V}$, $V_{OH} = 2.4\text{ V}$	1	1.7	2	ns
Fall Time	t_{f1}^1	$V_{OH} = 2.4\text{ V}$, $V_{OL} = 0.4\text{ V}$	1	1.76	2	ns
Duty Cycle	d_{t1}^1	$V_T = 1.5\text{ V}$	45	53.5	55	%
Jitter	$t_{jvc-cvc}^1$	$V_T = 1.5\text{ V}$		305	1000	ps

¹Guaranteed by design, not 100% tested in production.

Shared Pin Operation - Input/Output Pins

The I/O pins designated by (input/output) serve as dual signal functions to the device. During initial power-up, they act as input pins. The logic level (voltage) that is present on these pins at this time is read and stored into a 5-bit internal data latch. At the end of Power-On reset, (see AC characteristics for timing values), the device changes the mode of operations for these pins to an output function. In this mode the pins produce the specified buffered clocks to external loads.

To program (load) the internal configuration register for these pins, a resistor is connected to either the VDD (logic 1) power supply or the GND (logic 0) voltage potential. A 10 Kiloohm (10K) resistor is used to provide both the solid CMOS programming voltage needed during the power-up programming period and to provide an insignificant load on the output clock during the subsequent operating period.

Figure 1 shows a means of implementing this function when a switch or 2 pin header is used. With no jumper is installed the pin will be pulled high. With the jumper in place the pin will be pulled low. If programmability is not necessary, than only a single resistor is necessary. The programming resistors should be located close to the series termination resistor to minimize the current loop area. It is more important to locate the series termination resistor close to the driver than the programming resistor.

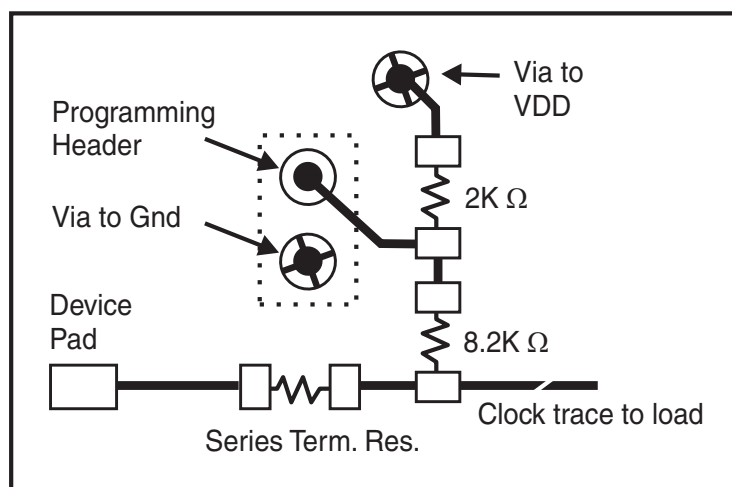
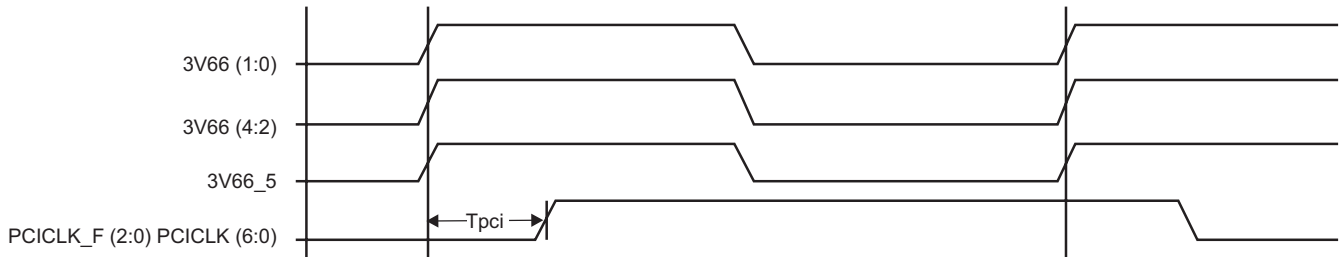

Fig. 1

3V66 & PCI Phase Relationship

All 3V66 clocks are to be in pphase with each other. In the case where 3V66_1 is configured as 48MHz VCH clock, there is no defined phase relationship between 3V66_1/VCH and other 3V66 clocks. The PCI group should lag 3V66 by the standard skew described below as Tpci.



Group Skews at Common Transition Edges

GROUP	SYMBOL	CONDITIONS	MIN	TYP	MAX	UNITS
3V66	3V66	3V66 (5:0) pin to pin skew	0		500	ps
PCI	PCI	PCI_F (2:0) and PCI (6:0) pin to pin skew	0		500	ps
3V66 to PCI	S _{3V66-PCI}	3V66 (5:0) leads 33MHz PCI	1.5		3.5	ns

¹Guaranteed by design, not 100% tested in production.

PD# Functionality

CPU_STOP#	CPUT	CPUC	3V66	66MHz_OUT	PCICLK_F PCICLK	PCICLK	USB/DOT 48MHz
1	Normal	Normal	66MHz	66MHz_IN	66MHz_IN	66MHz_IN	48MHz
0	iref * Mult	Float	Low	Low	Low	Low	Low

PCI_STOP# - Assertion (transition from logic "1" to logic "0")

The impact of asserting the PCI_STOP# signal will be the following. All PCI[6:0] and stoppable PCI_F[2,0] clocks will latch low in their next high to low transition. The PCI_STOP# setup time t_{su} is 10 ns, for transitions to be recognized by the next rising edge.

Assertion of PCI_STOP# Waveforms

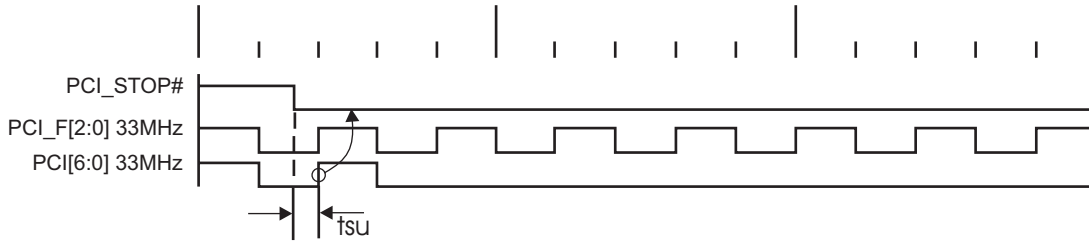

CPU_STOP# - Assertion (transition from logic "1" to logic "0")

The impact of asserting the CPU_STOP# pin is all CPU outputs that are set in the I²C configuration to be stoppable via assertion of CPU_STOP# are to be stopped after their next transition following the two CPU clock edge sampling as shown. The final state of the stopped CPU signals is CPUT=High and CPUC=Low. There is to be no change to the output drive current values. The CPUT will be driven high with a current value equal to (MULTSEL0) X (I REF), the CPUC signal will not be driven.

Assertion of CPU_STOP# Waveforms

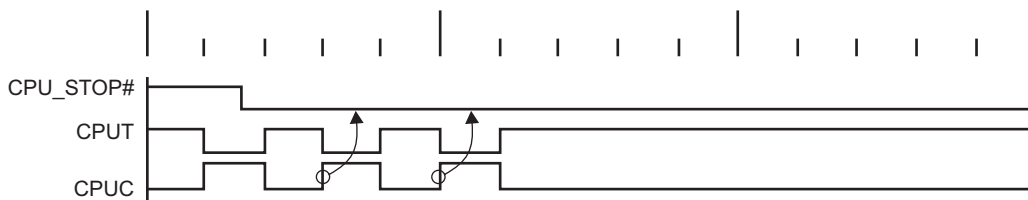

CPU_STOP# Functionality

CPU_STOP#	CPUT	CPUC
1	Normal	Normal
0	iref * Mult	Float

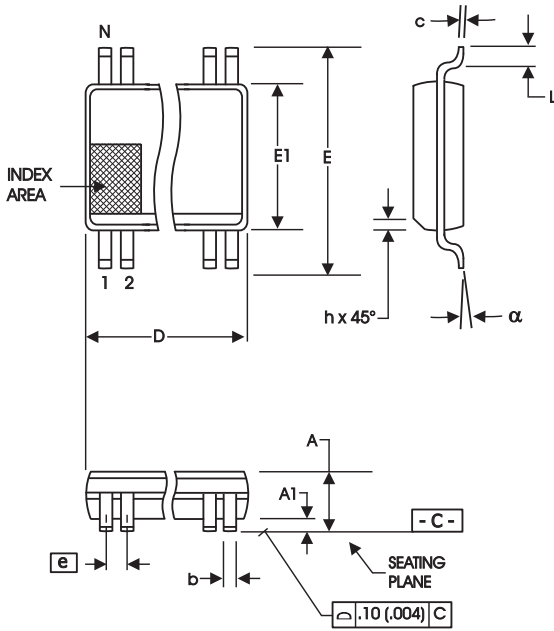

300 mil SSOP Package

SYMBOL	In Millimeters COMMON DIMENSIONS		In Inches COMMON DIMENSIONS	
	MIN	MAX	MIN	MAX
A	2.41	2.80	.095	.110
A1	0.20	0.40	.008	.016
b	0.20	0.34	.008	.0135
c	0.13	0.25	.005	.010
D	SEE VARIATIONS		SEE VARIATIONS	
E	10.03	10.68	.395	.420
E1	7.40	7.60	.291	.299
e	0.635 BASIC		0.025 BASIC	
h	0.38	0.64	.015	.025
L	0.50	1.02	.020	.040
N	SEE VARIATIONS		SEE VARIATIONS	
alpha	0°	8°	0°	8°

VARIATIONS

N	D mm.		D (inch)	
	MIN	MAX	MIN	MAX
48	15.75	16.00	.620	.630

Reference Doc.: JEDEC Publication 95, MO-118

10-0034

Ordering Information

ICS950220yFLFT

Example:

ICS XXXX y F LF - T

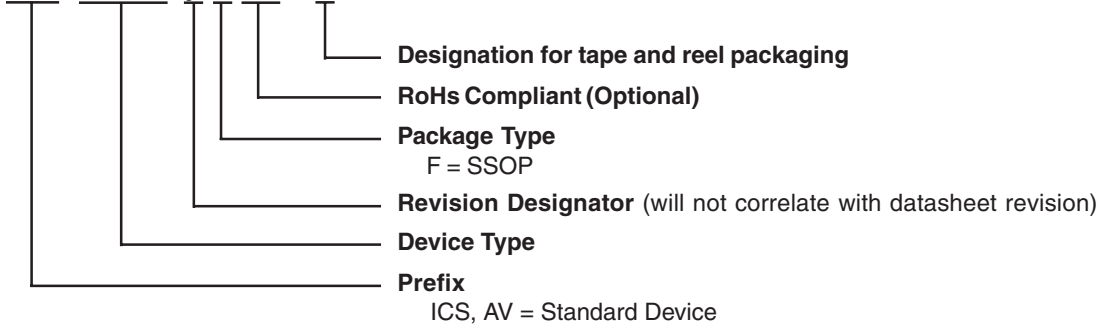

Revision History

Rev.	Issue Date	Description	Page #
F	7/28/2005	Added LF Ordering Information.	19
G	3/2/2007	Updated Electrical Characteristics CPU Skew spec.	13