

## PCIe Gen 2 and QPI Clock for Intel-based Servers

### Recommended Application:

PCIe Gen 2 & QPI compliant CK410B (CK410B+) clock for Intel-based servers

### Output Features:

- 4 - 0.7V current-mode differential CPU pairs
- 5 - 0.7V current-mode differential SRC pair
- 4 - PCI (33MHz)
- 3 - PCICLK\_F, (33MHz) free-running
- 1 - 48MHz
- 2 - REF, 14.318MHz

### Features/Benefits:

- Supports spread spectrum modulation, 0 to -0.5% down spread on CPU outputs
- Uses external 14.318MHz crystal and external load capacitors for low ppm synthesis error
- CPU clocks independent of SRC/PCI clocks
- D2/D3 SMBus address

### Key Specifications:

- Low drift PCIe clocks for Non-Transparent Bridging (NTB)
- PCIe Gen 2 compliant SRC outputs
- QPI & FBD compliant CPU clocks
- CPU cycle-cycle jitter: < 50ps
- SRC cycle-cycle jitter: < 125ps
- PCI cycle-cycle jitter: < 500ps
- CPU output skew: < 50ps
- SRC output skew: < 250ps
- $\pm 100$ ppm frequency accuracy on all outputs

### Functionality

FS_C <sup>1</sup>	FS_B <sup>1</sup>	FS_A <sup>2</sup>	CPU MHz	SRC MHz	PCI MHz	REF MHz	USB MHz
0	0	0	266.67	100.00	33.33	14.32	48.00
0	0	1	133.33				
0	1	0	200.00				
0	1	1	166.67				
1	0	0	333.33				
1	0	1	100.00				
1	1	0	400.00				
1	1	1	N/A				

1. FS\_B and FS\_C are three-level inputs. Please see  $V_{IL,FS}$  and  $V_{IH,FS}$  specifications in the Input/Supply/Common Output Parameters Table for correct values. Also refer to the Test Clarification Table.

Also refer to the Test Clarification Table.

2. FS\_A is a low-threshold input. Please see the  $V_{IL,FS}$  and  $V_{IH,FS}$  specifications in the Input/Supply/Common Output Parameters Table for correct values.

### Pin Configuration

VDDPCI	1	56	FS_C/TEST_SEL
GNDPCI	2	55	REF0
PCICLK0	3	54	REF1
PCICLK1	4	53	VDDREF
PCICLK2	5	52	X1
PCICLK3	6	51	X2
GNDPCI	7	50	GNDREF
VDDPCI	8	49	FS_B/TEST_MODE
PCICLK_F0	9	48	FS_A
PCICLK_F1	10	47	VDDCPU
PCICLK_F2	11	46	CPUCLKT0
VDD48	12	45	CPUCLKC0
48MHz	13	44	VDDCPU
GND48	14	43	CPUCLKT1
VDDSRC	15	42	CPUCLKC1
SRCCLKT0	16	41	GNDCPU
SRCCLKC0	17	40	CPUCLKT2
SRCCLKC1	18	39	CPUCLKC2
SRCCLKT1	19	38	VDDCPU
GNDSRC	20	37	CPUCLKT3
SRCCLKT2	21	36	CPUCLKC3
SRCCLKC2	22	35	VDDA
SRCCLKC3	23	34	GND A
SRCCLKT3	24	33	IREF
VDDSRC	25	32	NC
SRCCLKT4	26	31	Vtt_PwrGd#/PD
SRCCLKC4	27	30	SDATA
VDDSRC	28	29	SCLK

56-pin TSSOP



## Pin Description

Pin #	PIN NAME	PIN TYPE	DESCRIPTION
1	VDDPCI	PWR	Power supply for PCI clocks, nominal 3.3V
2	GNDPCI	PWR	Ground pin for the PCI outputs
3	PCICLK0	OUT	PCI clock output.
4	PCICLK1	OUT	PCI clock output.
5	PCICLK2	OUT	PCI clock output.
6	PCICLK3	OUT	PCI clock output.
7	GNDPCI	PWR	Ground pin for the PCI outputs
8	VDDPCI	PWR	Power supply for PCI clocks, nominal 3.3V
9	PCICLK_F0	OUT	Free running PCI clock not affected by PCI_STOP# .
10	PCICLK_F1	OUT	Free running PCI clock not affected by PCI_STOP# .
11	PCICLK_F2	OUT	Free running PCI clock not affected by PCI_STOP# .
12	VDD48	PWR	Power pin for the 48MHz output.3.3V
13	48MHz	OUT	48MHz clock output.
14	GND48	PWR	Ground pin for the 48MHz outputs
15	VDDSRC	PWR	Supply for SRC clocks, 3.3V nominal
16	SRCCLK0	OUT	True clock of differential SRC clock pair.
17	SRCCLKC0	OUT	Complement clock of differential SRC clock pair.
18	SRCCLK1	OUT	Complement clock of differential push-pull SRC clock pair.
19	SRCCLKT1	OUT	True clock of differential SRC clock pair.
20	GNSRC	PWR	Ground pin for the SRC outputs
21	SRCCLK2	OUT	True clock of differential SRC clock pair.
22	SRCCLKC2	OUT	Complement clock of differential SRC clock pair.
23	SRCCLKC3	OUT	Complement clock of differential SRC clock pair.
24	SRCCLK3	OUT	True clock of differential SRC clock pair.
25	VDDSRC	PWR	Supply for SRC clocks, 3.3V nominal
26	SRCCLK4	OUT	True clock of differential SRC clock pair.
27	SRCCLKC4	OUT	Complement clock of differential SRC clock pair.
28	VDDSRC	PWR	Supply for SRC clocks, 3.3V nominal



### Pin Description (Continued)

Pin #	PIN NAME	Type	Pin Description
29	SCLK	IN	Clock pin of SMBus circuitry, 5V tolerant.
30	SDATA	I/O	Data pin for SMBus circuitry, 3.3V tolerant.
31	Vtt_PwrGd#/PD	IN	Vtt_PwrGd# is an active low input used to determine when latched inputs are ready to be sampled. PD is an asynchronous active high input pin used to put the device into a low power state. The internal clocks, PLLs and the crystal oscillator are stopped.
32	NC	N/A	No Connection.
33	IREF	OUT	This pin establishes the reference current for the differential current-mode output pairs. This pin requires a fixed precision resistor tied to ground in order to establish the appropriate current. 475 ohms is the standard value.
34	GNDA	PWR	Ground pin for the PLL core.
35	VDDA	PWR	3.3V power for the PLL core.
36	CPUCLKC3	OUT	Complementary clock of differential pair CPU outputs. These are current mode outputs. External resistors are required for voltage bias.
37	CPUCLKT3	OUT	True clock of differential pair CPU outputs. These are current mode outputs. External resistors are required for voltage bias.
38	VDDCPU	PWR	Supply for CPU clocks, 3.3V nominal
39	CPUCLKC2	OUT	Complementary clock of differential pair CPU outputs. These are current mode outputs. External resistors are required for voltage bias.
40	CPUCLKT2	OUT	True clock of differential pair CPU outputs. These are current mode outputs. External resistors are required for voltage bias.
41	GNDCPU	PWR	Ground pin for the CPU outputs
42	CPUCLKC1	OUT	Complementary clock of differential pair CPU outputs. These are current mode outputs. External resistors are required for voltage bias.
43	CPUCLKT1	OUT	True clock of differential pair CPU outputs. These are current mode outputs. External resistors are required for voltage bias.
44	VDDCPU	PWR	Supply for CPU clocks, 3.3V nominal
45	CPUCLKC0	OUT	Complementary clock of differential pair CPU outputs. These are current mode outputs. External resistors are required for voltage bias.
46	CPUCLKT0	OUT	True clock of differential pair CPU outputs. These are current mode outputs. External resistors are required for voltage bias.
47	VDDCPU	PWR	Supply for CPU clocks, 3.3V nominal
48	FS_A	IN	3.3V tolerant input for CPU frequency selection. Refer to input electrical characteristics for V <sub>il_FS</sub> and V <sub>ih_FS</sub> values.
49	FS_B/TEST_MODE	IN	3.3V tolerant input for CPU frequency selection. Refer to input electrical characteristics for V <sub>il_FS</sub> and V <sub>ih_FS</sub> values. TEST_MODE is a real time input to select between Hi-Z and REF/N divider mode while in test mode. Refer to Test Clarification Table.
50	GNDREF	PWR	Ground pin for the REF outputs.
51	X2	OUT	Crystal output, Nominally 14.318MHz
52	X1	IN	Crystal input, Nominally 14.318MHz.
53	VDDREF	PWR	Ref, XTAL power supply, nominal 3.3V
54	REF1	OUT	14.318 MHz reference clock.
55	REF0	OUT	14.318 MHz reference clock.
56	FS_C/TEST_SEL	IN	3.3V tolerant input for CPU frequency selection. Low voltage threshold inputs, see input electrical characteristics for V <sub>il_FS</sub> and V <sub>ih_FS</sub> values. TEST_Sel: 3-level latched input to enable test mode. Refer to Test Clarification Table

### General Description

**ICS932S431A** is a main clock synthesizer for CK410B-generation Intel server platforms. **ICS932S431A** is driven with a 14.318MHz crystal. It generates CPU outputs up to 400MHz and PCI-Express clocks at 100. The 48 MHz USB clock is an exact 48.000 MHz clock. The **ICS932S431A** generates all other clocks with less the +/- 300 ppm error.

### Block Diagram

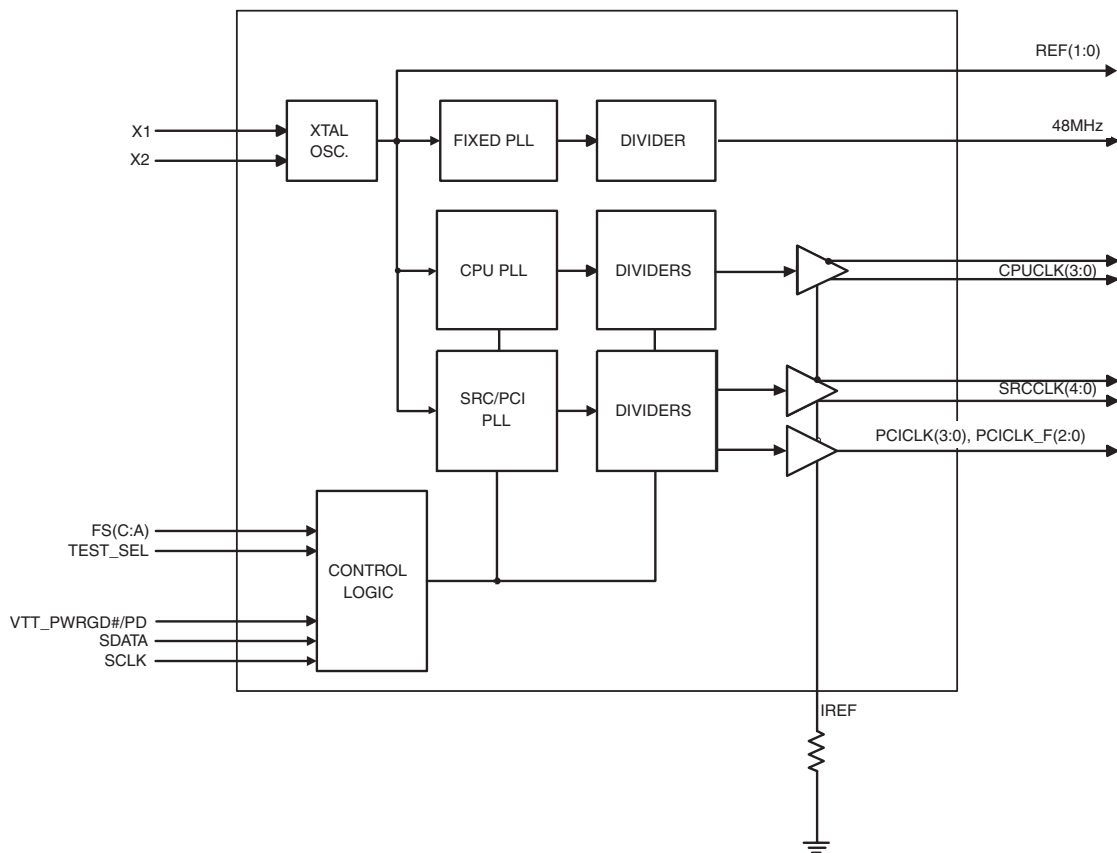

### Power Groups

Pin Number		Description
VDD	GND	
53	50	Xtal, Ref
1,8	2,7	PCICLK outputs
15,25,28	20	SRCCLK outputs
35	34	Master clock, CPU Analog
12	14	48MHz, PLL_48
47,44,38	41	CPUCLK clocks

### Absolute Maximum Rating

PARAMETER	SYMBOL	CONDITIONS	MIN	TYP	MAX	UNITS	Notes
3.3V Core Supply Voltage	VDD_A	-			V <sub>DD</sub> + 0.5V	V	1
3.3V Logic Input Supply Voltage	VDD_In	-	GND - 0.5		V <sub>DD</sub> + 0.5V	V	1
Storage Temperature	T <sub>s</sub>	-	-65		150	°C	1
Ambient Operating Temp	T <sub>ambient</sub>	-	0		70	°C	1
Case Temperature	T <sub>case</sub>	-			115	°C	1
Input ESD protection HBM	ESD prot	-	2000			V	1

<sup>1</sup>Guaranteed by design and characterization, not 100% tested in production.

### Electrical Characteristics - Input/Supply/Common Output Parameters

PARAMETER	SYMBOL	CONDITIONS*	MIN	TYP	MAX	UNITS	Notes
Input High Voltage	V <sub>IH</sub>	3.3 V +/-5%	2		V <sub>DD</sub> + 0.3	V	1
Input Low Voltage	V <sub>IL</sub>	3.3 V +/-5%	V <sub>SS</sub> - 0.3		0.8	V	1
Input High Current	I <sub>IH</sub>	V <sub>IN</sub> = V <sub>DD</sub>	-5		5	uA	1
Input Low Current	I <sub>IL1</sub>	V <sub>IN</sub> = 0 V; Inputs with no pull-up resistors	-5			uA	1
	I <sub>IL2</sub>	V <sub>IN</sub> = 0 V; Inputs with pull-up resistors	-200			uA	1
Low Threshold Input-High Voltage	V <sub>IH_FS</sub>	3.3 V +/-5%	0.7		V <sub>DD</sub> + 0.3	V	1
Low Threshold Input-Low Voltage	V <sub>IL_FS</sub>	3.3 V +/-5%	V <sub>SS</sub> - 0.3		0.35	V	1
Operating Supply Current	I <sub>DD3.3OP</sub>	Full Active, C <sub>L</sub> = Full load;			350	mA	1
Powerdown Current	I <sub>DD3.3PD</sub>	all diff pairs driven			70	mA	1
		all differential pairs tri-stated			12	mA	1
Input Frequency	F <sub>i</sub>	V <sub>DD</sub> = 3.3 V		14.31818		MHz	2
Pin Inductance	L <sub>pin</sub>				7	nH	1
Input Capacitance	C <sub>IN</sub>	Logic Inputs			5	pF	1
	C <sub>OUT</sub>	Output pin capacitance			6	pF	1
	C <sub>INX</sub>	X1 & X2 pins			5	pF	1
Clk Stabilization	T <sub>STAB</sub>	From VDD Power-Up or de-assertion of PD to 1st clock			1.8	ms	1
Modulation Frequency		Triangular Modulation	30		33	kHz	1
Tdrive_PD		CPU output enable after PD de-assertion			300	us	1
Tfall_PD		PD fall time of			5	ns	1
Trise_PD		PD rise time of			5	ns	1
SMBus Voltage	V <sub>DD</sub>		2.7		5.5	V	1
Low-level Output Voltage	V <sub>OL</sub>	@ I <sub>PULLUP</sub>			0.4	V	1
Current sinking at V <sub>OL</sub> = 0.4 V	I <sub>PULLUP</sub>		4			mA	1
SCLK/SDATA Clock/Data Rise Time	T <sub>RI2C</sub>	(Max V <sub>IL</sub> - 0.15) to (Min V <sub>IH</sub> + 0.15)			1000	ns	1
SCLK/SDATA Clock/Data Fall Time	T <sub>FI2C</sub>	(Min V <sub>IH</sub> + 0.15) to (Max V <sub>IL</sub> - 0.15)			300	ns	1

\*TA = 0 - 70°C; Supply Voltage VDD = 3.3 V +/-5%

<sup>1</sup>Guaranteed by design and characterization, not 100% tested in production.

<sup>2</sup> Input frequency should be measured at the REF pin and tuned to ideal 14.31818MHz to meet ppm frequency accuracy on PLL outputs.

### Electrical Characteristics - CPU 0.7V Current Mode Differential Pair

PARAMETER	SYMBOL	CONDITIONS*	MIN	TYP	MAX	UNITS	NOTES
Current Source Output Impedance	Zo	VO = Vx	3000			Ω	1
Voltage High	VHigh	Statistical measurement on single ended signal	660		850	mV	1,3
Voltage Low	VLow		-150		150	mV	1,3
Max Voltage	Vovs	Measurement on single ended signal using absolute value.			1150	mV	1
Min Voltage	Vuds		-300			mV	1
Crossing Voltage (abs)	Vx(abs)		250		550	mV	1
Crossing Voltage (var)	d-Vx	Variation of crossing over all edges			140	mV	1
Rise Time	tr	V <sub>OL</sub> = 0.175V, V <sub>OH</sub> = 0.525V	175		525	ps	1
Fall Time	tf	V <sub>OL</sub> = 0.175V, V <sub>OH</sub> = 0.525V	175		525	ps	1
Rise Time Variation	d-tr	V <sub>OL</sub> = 0.175V, V <sub>OH</sub> = 0.525V			125	ps	1
Fall Time Variation	d-tf	V <sub>OL</sub> = 0.175V, V <sub>OH</sub> = 0.525V			125	ps	1
Duty Cycle	dt3	Measurement from differential waveform	45		55	%	1
Skew	tsk3	across all CPU outputs, VT = 50%			50	ps	1
Jitter, Cycle to cycle	t <sub>jcy-cyc</sub>	Measurement from differential waveform			50	ps	1

\*T<sub>A</sub> = 0 - 70°C; V<sub>DD</sub> = 3.3 V +/-5%; C<sub>L</sub> =2pF, R<sub>S</sub>=33.2Ω, R<sub>P</sub>=49.9Ω, I<sub>REF</sub> = 475Ω

<sup>1</sup>Guaranteed by design and characterization, not 100% tested in production.

<sup>2</sup>All Long Term Accuracy and Clock Period specifications are guaranteed assuming that REF is at 14.31818MHz

<sup>3</sup>I<sub>REF</sub> = V<sub>DD</sub>/(3xR<sub>R</sub>). For R<sub>R</sub> = 475Ω (1%), I<sub>REF</sub> = 2.32mA. I<sub>OH</sub> = 6 x I<sub>REF</sub> and V<sub>OH</sub> = 0.7V @ Z<sub>O</sub>=50Ω.

### Electrical Characteristics - SRC 0.7V Current Mode Differential Pair

PARAMETER	SYMBOL	CONDITIONS*	MIN	TYP	MAX	UNITS	Notes
Current Source Output Impedance	Zo	VO = Vx	3000			Ω	1
Voltage High	VHigh	Statistical measurement on single ended signal	660		850	mV	1,3
Voltage Low	VLow		-150		150	mV	1,3
Max Voltage	Vovs	Measurement on single ended signal using absolute value.			1150	mV	1
Min Voltage	Vuds		-300			mV	1
Crossing Voltage (abs)	Vx(abs)		250		550	mV	1
Crossing Voltage (var)	d-Vx	Variation of crossing over all edges			140	mV	1
Rise Time	tr	V <sub>OL</sub> = 0.175V, V <sub>OH</sub> = 0.525V	175		525	ps	1
Fall Time	tf	V <sub>OH</sub> = 0.525V V <sub>OL</sub> = 0.175V	175		525	ps	1
Rise Time Variation	d-tr	V <sub>OL</sub> = 0.175V, V <sub>OH</sub> = 0.525V			125	ps	1
Fall Time Variation	d-tf	V <sub>OH</sub> = 0.525V V <sub>OL</sub> = 0.175V			125	ps	1
Long Term Jitter	t <sub>jLT</sub>	Measurement from differential waveform @ 10 us	0	300	500	ps	1
Duty Cycle	dt3	Measurement from differential waveform	45		55	%	1
Skew	tsk3	VT = 50%			250	ps	1
Jitter, Cycle to cycle	t <sub>jcy-cyc</sub>	Measurement from differential waveform			125	ps	1

\*T<sub>A</sub> = 0 - 70°C; V<sub>DD</sub> = 3.3 V +/-5%; C<sub>L</sub> =2pF, R<sub>S</sub>=33.2Ω, R<sub>P</sub>=49.9Ω, I<sub>REF</sub> = 475Ω

<sup>1</sup>Guaranteed by design and characterization, not 100% tested in production.

<sup>2</sup>All Long Term Accuracy and Clock Period specifications are guaranteed assuming that REF is at 14.31818MHz

<sup>3</sup>I<sub>REF</sub> = V<sub>DD</sub>/(3xR<sub>R</sub>). For R<sub>R</sub> = 475Ω (1%), I<sub>REF</sub> = 2.32mA. I<sub>OH</sub> = 6 x I<sub>REF</sub> and V<sub>OH</sub> = 0.7V @ Z<sub>O</sub>=50Ω.

### Electrical Characteristics - PCICLK/PCICLK\_F

PARAMETER	SYMBOL	CONDITIONS*	MIN	TYP	MAX	UNITS	NOTES
Long Accuracy	ppm	see Tperiod min-max values	-100		100	ppm	1,2
Clock period	T <sub>period</sub>	33.33MHz output nominal	29.9970	30	30.0030	ns	2
Absolute Clock period	T <sub>pabs</sub>	33.33MHz output including jitter	29.4970		30.5030	ns	2
Clock High Time	T <sub>HIGH</sub>	1.5V	12		N/A	ns	1
Clock Low Time	T <sub>LOW</sub>	1.5V	12		N/A	ns	1
Output Impedance	R <sub>DSP</sub>	V <sub>O</sub> = V <sub>DD</sub> *(0.5)	12		55		1
Output High Voltage	V <sub>OH</sub>	I <sub>OH</sub> = -1 mA	2.4			V	1
Output Low Voltage	V <sub>OL</sub>	I <sub>OL</sub> = 1 mA			0.55	V	1
Output High Current	I <sub>OH</sub>	V <sub>OH</sub> @ MIN = 1.0 V	-33			mA	1
		V <sub>OH</sub> @ MAX = 3.135 V			-33	mA	1
Output Low Current	I <sub>OL</sub>	V <sub>OL</sub> @ MIN = 1.95 V	30			mA	1
		V <sub>OL</sub> @ MAX = 0.4 V			38	mA	1
Edge Rate	t <sub>slewr/f</sub>	Rising/Falling edge rate	1		4	V/ns	1
Rise Time	t <sub>r</sub>	V <sub>OL</sub> = 0.4 V, V <sub>OH</sub> = 2.4 V	0.5		2	ns	1
Fall Time	t <sub>f</sub>	V <sub>OH</sub> = 2.4 V, V <sub>OL</sub> = 0.4 V	0.5		2	ns	1
Duty Cycle	d <sub>t1</sub>	V <sub>T</sub> = 1.5 V	45		55	%	1
Group Skew	t <sub>skew</sub>	V <sub>T</sub> = 1.5 V			250	ps	1
Jitter, Cycle to cycle	t <sub>jyc-cyc</sub>	V <sub>T</sub> = 1.5 V			500	ps	1

\*TA = 0 - 70°C; Supply Voltage VDD = 3.3 V +/-5%, (unless otherwise specified)

<sup>1</sup>Guaranteed by design and characterization, not 100% tested in production.

<sup>2</sup>All Long Term Accuracy and Clock Period specifications are guaranteed assuming that REF is at 14.31818MHz

### Electrical Characteristics - USB48MHz

PARAMETER	SYMBOL	CONDITIONS*	MIN	TYP	MAX	UNITS	NOTES
Long Accuracy	ppm	see Tperiod min-max values	0		0	ppm	1,2
Clock period	T <sub>period</sub>	48.00MHz output nominal	20.8333	20.83333	20.8333	ns	2
Absolute Clock period	T <sub>pabs</sub>	48.00MHz output including jitter	20.4833		21.1833	ns	2
Output Impedance	R <sub>DSP</sub>	V <sub>O</sub> = V <sub>DD</sub> *(0.5)	12		55	Ω	1
Output High Voltage	V <sub>OH</sub>	I <sub>OH</sub> = -1 mA	2.4			V	1
Clock High Time	T <sub>HIGH</sub>	1.5V	8.094		10.036	ns	1
Clock Low Time	T <sub>LOW</sub>	1.5V	7.694		9.836	ns	1
Output Low Voltage	V <sub>OL</sub>	I <sub>OL</sub> = 1 mA			0.55	V	1
Output High Current	I <sub>OH</sub>	V <sub>OH</sub> @ MIN = 1.0 V	-29			mA	1
		V <sub>OH</sub> @ MAX = 3.135 V			-33	mA	1
Output Low Current	I <sub>OL</sub>	V <sub>OL</sub> @ MIN = 1.95 V	29			mA	1
		V <sub>OL</sub> @ MAX = 0.4 V			27	mA	1
Edge Rate	t <sub>slewr/f USB</sub>	Rising/Falling edge rate	1		2	V/ns	1
Rise Time	t <sub>r USB</sub>	V <sub>OL</sub> = 0.4 V, V <sub>OH</sub> = 2.4 V	1		2	ns	1
Fall Time	t <sub>f USB</sub>	V <sub>OH</sub> = 2.4 V, V <sub>OL</sub> = 0.4 V	1		2	ns	1
Duty Cycle	d <sub>t1</sub>	V <sub>T</sub> = 1.5 V	45		55	%	1
Group Skew	t <sub>skew</sub>	V <sub>T</sub> = 1.5 V			250	ps	1
Jitter, Cycle to cycle	t <sub>jyc-cyc</sub>	V <sub>T</sub> = 1.5 V			350	ps	1

\*TA = 0 - 70°C; Supply Voltage VDD = 3.3 V +/-5%

<sup>1</sup>Guaranteed by design and characterization, not 100% tested in production.

<sup>2</sup>All Long Term Accuracy and Clock Period specifications are guaranteed assuming that REF is at 14.31818MHz

### Electrical Characteristics - REF

PARAMETER	SYMBOL	CONDITIONS	MIN	TYP	MAX	UNITS	Notes
Long Accuracy	ppm	see Tperiod min-max values	-100	0	100	ppm	1,2
Clock period	T <sub>period</sub>	14.318MHz output nominal	69.8343	69.84128	69.8483	ns	2
Absolute Clock period	T <sub>pabs</sub>	14.318MHz output including jitter	68.8343		70.8483	ns	2
Clock High Time	T <sub>HIGH</sub>	1.5V	27.533718		N/A	ns	1
Clock Low Time	T <sub>LOW</sub>	1.5V	27.533718		N/A	ns	1
Output High Voltage	V <sub>OH</sub>	I <sub>OH</sub> = -1 mA	2.4			V	1
Output Low Voltage	V <sub>OL</sub>	I <sub>OL</sub> = 1 mA			0.4	V	1
Output High Current	I <sub>OH</sub>	V <sub>OH</sub> @MIN = 1.0 V	-33			mA	1
		V <sub>OH</sub> @MAX = 3.135 V			-33	mA	1
Output Low Current	I <sub>OL</sub>	V <sub>OL</sub> @ MIN = 1.95 V	30			mA	1
		V <sub>OL</sub> @ MAX = 0.4 V			38	mA	1
Edge Rate	t <sub>slewr/f</sub>	Rising/Falling edge rate	1		4	V/ns	1
Rise Time	t <sub>r1</sub>	V <sub>OL</sub> = 0.4 V, V <sub>OH</sub> = 2.4 V	0.5		2	ns	1
Fall Time	t <sub>f1</sub>	V <sub>OH</sub> = 2.4 V, V <sub>OL</sub> = 0.4 V	0.5		2	ns	1
Skew	t <sub>sk1</sub>	V <sub>T</sub> = 1.5 V			500	ps	1
Duty Cycle	d <sub>t1</sub>	V <sub>T</sub> = 1.5 V	45		55	%	1
Jitter	t <sub>jcyc-cyc</sub>	V <sub>T</sub> = 1.5 V			1000	ps	1

\*TA = 0 - 70°C; Supply Voltage VDD = 3.3 V +/-5%

<sup>1</sup>Guaranteed by design and characterization, not 100% tested in production.

<sup>2</sup>All Long Term Accuracy and Clock Period specifications are guaranteed assuming that REF is at 14.31818MHz

### Electrical Characteristics - Differential Jitter Parameters

PARAMETER	Symbol	Conditions	Min	TYP	Max	Units	Notes
Jitter, Phase	t <sub>jphasePLL</sub>	PCIe Gen 1		30	86	ps (p-p)	1,2
	t <sub>jphaseLo</sub>	PCIe Gen 2 10kHz < f < 1.5MHz		0.9	3	ps (RMS)	1,2
	t <sub>jphaseHigh</sub>	PCIe Gen 2 1.5MHz < f < Nyquist (50MHz)		1.9	3.1	ps (RMS)	1,2
	t <sub>jphFBD1_3.2G</sub>	FBD1 3.2/4G 11MHz to 33MHz		1.9	3	ps (RMS)	1,2
	t <sub>jphFBD1_4.0G</sub>	FBD1 4.8G 11MHz to 33MHz		1.4	2.5	ps (RMS)	1,2
	t <sub>jphQPI</sub>	QPI 133MHz 6.4GB_12UI CPU outputs only		0.18	0.5	ps (RMS)	1,2

\*TA = 0 - 70°C; Supply Voltage VDD = 3.3 V +/-5%

<sup>1</sup>Guaranteed by design and characterization, not 100% tested in production.

<sup>2</sup>See <http://www.pcisig.com> for complete specs

### Electrical Characteristics - REF-14.318MHz

$T_A = 0 - 70^\circ\text{C}$ ;  $V_{DD} = 3.3\text{ V} \pm 5\%$ ;  $C_L = 5\text{ pF}$  (unless otherwise specified)

PARAMETER	SYMBOL	CONDITIONS	MIN	TYP	MAX	UNITS	NOTES
Long Accuracy	ppm	see Tperiod min-max values	-300	0	300	ppm	1
Clock period	$T_{\text{period}}$	14.318MHz output nominal	69.82033		69.86224	ns	1
Absolute Min/Max Clock period	$T_{\text{abs}}$	Nominal	68.82033		70.86224	ns	2
Output High Voltage	$V_{OH}$	$I_{OH} = -1\text{ mA}$	2.4			V	1
Output Low Voltage	$V_{OL}$	$I_{OL} = 1\text{ mA}$			0.4	V	1
Output High Current	$I_{OH}$	$V_{OH} @ \text{MIN} = 1.0\text{ V}$ , $V_{OH} @ \text{MAX} = 3.135\text{ V}$	-29		-23	mA	1
Output Low Current	$I_{OL}$	$V_{OL} @ \text{MIN} = 1.95\text{ V}$ , $V_{OL} @ \text{MAX} = 0.4\text{ V}$	29		27	mA	1
Rise Time	$t_{r1}$	$V_{OL} = 0.4\text{ V}$ , $V_{OH} = 2.4\text{ V}$	0.5		2	ns	1
Fall Time	$t_{f1}$	$V_{OH} = 2.4\text{ V}$ , $V_{OL} = 0.4\text{ V}$	0.5		2	ns	1
Skew	$t_{sk1}$	$V_T = 1.5\text{ V}$			500	ps	1
Duty Cycle	$d_{t1}$	$V_T = 1.5\text{ V}$	45		55	%	1
Jitter	$t_{j\text{cyc-cyc}}$	$V_T = 1.5\text{ V}$			1000	ps	1

<sup>1</sup>Guaranteed by design, not 100% tested in production.

**Single-ended Output Terminations**

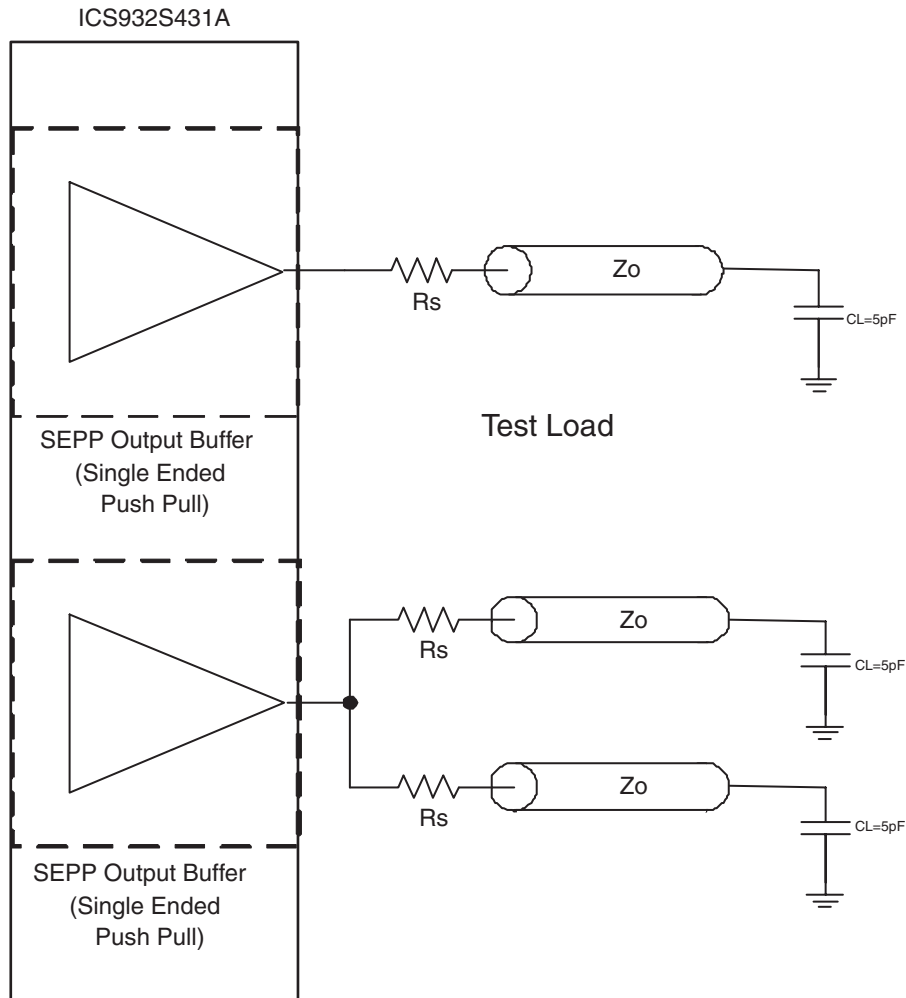

The singled-ended outputs of the ICS 932S4231A default to a drive strength of 2 loads. The REF clocks can be turned down to 1-load strength via the SMBus. Suggested termination resistors are as follows for transmission lines with  $Z_o = 50$  ohms:

Single-ended outputs at 2-load strength (Power up default for all single-ended outputs)	Driving 1 load, $R_s = 33$ ohms
	Driving 2 loads, $R_s = 7.5$ ohms
Single-ended outputs at 1-load strength (REF clock only)	Driving 1 load, $R_s = 22$ ohms

## General SMBus serial interface information for the ICS932S431A

### How to Write:

- Controller (host) sends a start bit.
- Controller (host) sends the write address  $D2_{(H)}$
- ICS clock will **acknowledge**
- Controller (host) sends the beginning byte location = N
- ICS clock will **acknowledge**
- Controller (host) sends the data byte count = X
- ICS clock will **acknowledge**
- Controller (host) starts sending **Byte N through Byte N + X - 1**  
(see Note 2)
- ICS clock will **acknowledge** each byte **one at a time**
- Controller (host) sends a Stop bit

### How to Read:

- Controller (host) will send start bit.
- Controller (host) sends the write address  $D2_{(H)}$
- ICS clock will **acknowledge**
- Controller (host) sends the beginning byte location = N
- ICS clock will **acknowledge**
- Controller (host) will send a separate start bit.
- Controller (host) sends the read address  $D3_{(H)}$
- ICS clock will **acknowledge**
- ICS clock will send the data byte count = X
- ICS clock sends **Byte N + X - 1**
- ICS clock sends **Byte 0 through byte X (if  $X_{(H)}$  was written to byte 8)**.
- Controller (host) will need to acknowledge each byte
- Controller (host) will send a not acknowledge bit
- Controller (host) will send a stop bit

Index Block Write Operation		
Controller (Host)		ICS (Slave/Receiver)
T	starT bit	
Slave Address $D2_{(H)}$		
WR	WRite	
		ACK
Beginning Byte = N		
		ACK
Data Byte Count = X		
		ACK
Beginning Byte N		
	X Byte	ACK
○		○
○		○
○		○
Byte N + X - 1		
		ACK
P	stoP bit	

Index Block Read Operation		
Controller (Host)		ICS (Slave/Receiver)
T	starT bit	
Slave Address $D2_{(H)}$		
WR	WRite	
		ACK
Beginning Byte = N		
		ACK
RT	Repeat starT	
Slave Address $D3_{(H)}$		
RD	ReaD	
		ACK
		Data Byte Count = X
ACK		
		Beginning Byte N
ACK		
	X Byte	○
○		○
○		○
○		○
		Byte N + X - 1
N	Not acknowledge	
P	stoP bit	



SMBus Table: Output Enable Register

Byte 0	Pin #	Name	Control Function	Type	0	1	PWD
Bit 7	NA	SRCCLK7 Enable	Output Enable	RW	Disable-Hi-Z	Enable	1
Bit 6	NA	SRCCLK6 Enable	Output Enable	RW	Disable-Hi-Z	Enable	1
Bit 5	NA	SRCCLK5 Enable	Output Enable	RW	Disable-Hi-Z	Enable	1
Bit 4	26,27	SRCCLK4 Enable	Output Enable	RW	Disable-Hi-Z	Enable	1
Bit 3	23,24	SRCCLK3 Enable	Output Enable	RW	Disable-Hi-Z	Enable	1
Bit 2	21,22	SRCCLK2 Enable	Output Enable	RW	Disable-Hi-Z	Enable	1
Bit 1	18,19	SRCCLK1 Enable	Output Enable	RW	Disable-Hi-Z	Enable	1
Bit 0	16,17	SRCCLK0 Enable	Output Enable	RW	Disable-Hi-Z	Enable	1

SMBus Table: Output Enable Register

Byte 1	Pin #	Name	Control Function	Type	0	1	PWD
Bit 7	54	REF1 Enable	Output Enable	RW	Disable-Low	Enable	1
Bit 6	55	REF0 Enable	Output Enable	RW	Disable-Low	Enable	1
Bit 5	36,37	CPUCLK3	Output Enable	RW	Disable-Hi-Z	Enable	1
Bit 4	39,40	CPUCLK2	Output Enable	RW	Disable-Hi-Z	Enable	1
Bit 3		RESERVED					0
Bit 2	42,43	CPUCLK1	Output Enable	RW	Disable-Hi-Z	Enable	1
Bit 1	45,46	CPUCLK0	Output Enable	RW	Disable-Hi-Z	Enable	1
Bit 0	CPU	Spread Spectrum Enable (CPU outputs only)	Spread Off/On	RW	Spread Off	Spread On	0

SMBus Table: Output Enable Register

Byte 2	Pin #	Name	Control Function	Type	0	1	PWD
Bit 7	6	PCICLK3	Output Enable	RW	Disable-Low	Enable	1
Bit 6	5	PCICLK2	Output Enable	RW	Disable-Low	Enable	1
Bit 5	4	PCICLK1	Output Enable	RW	Disable-Low	Enable	1
Bit 4	3	PCICLK0	Output Enable	RW	Disable-Low	Enable	1
Bit 3	11	PCICLK_F2 Enable	Output Enable	RW	Disable-Low	Enable	1
Bit 2	10	PCICLK_F1 Enable	Output Enable	RW	Disable-Low	Enable	1
Bit 1	9	PCICLK_F0 Enable	Output Enable	RW	Disable-Low	Enable	1
Bit 0	13	48MHz Enable	Output Enable	RW	Disable-Low	Enable	1

SMBus Table: Stop Control Register

Byte 3	Pin #	Name	Control Function	Type	0	1	PWD
Bit 7	11	PCICLK_F2 Stop En	Free-Running Control, Default: not affected by PCI/SRC_STOP (Byte 4, bit 5)	RW	Free-Running	Stoppable	1
Bit 6	10	PCICLK_F1 Stop En		RW	Free-Running	Stoppable	1
Bit 5	9	PCICLK_F0 Stop En		RW	Free-Running	Stoppable	1
Bit 4	26,27	SRCCLK4 Stop En		RW	Free-Running	Stoppable	1
Bit 3	23,24	SRCCLK3 Stop En		RW	Free-Running	Stoppable	1
Bit 2	21,22	SRCCLK2 Stop En		RW	Free-Running	Stoppable	1
Bit 1	18,19	SRCCLK1 Stop En		RW	Free-Running	Stoppable	1
Bit 0	16,17	SRCCLK0 Stop En		RW	Free-Running	Stoppable	1



**SMBus Table: Stop and Power Down Mode Drive Control Register**

Byte 4	Pin #	Name	Control Function	Type	0	1	PWD
Bit 7	36,37	CPUCLK3 PD Drive	Drive Mode in PD	RW	Driven	Hi-Z	0
Bit 6	39,40	CPUCLK2 PD Drive	Drive Mode in PD	RW	Driven	Hi-Z	0
Bit 5	42,43	CPUCLK1 PD Drive	Drive mode in PD	RW	Driven	Hi-Z	0
Bit 4	45,46	CPUCLK0 PD Drive	Drive mode in PD	RW	Driven	Hi-Z	0
Bit 3	36,37	CPUCLK3 Stop En	Free-Running Control, Default: not affected by CPU_STOP	RW	Free-Running	Stoppable	1
Bit 2	39,40	CPUCLK2 Stop En		RW	Free-Running	Stoppable	1
Bit 1	42,43	CPUCLK1 Stop En		RW	Free-Running	Stoppable	1
Bit 0	45,46	CPUCLK0 Stop En		RW	Free-Running	Stoppable	1

**SMBus Table: Stop and Power Down Mode Drive Control Register**

Byte 5	Pin #	Name	Control Function	Type	0	1	PWD
Bit 7		RESERVED					0
Bit 6	SRC	SRC Stop Drive Mode	Driven in STOP	RW	Driven	Hi-Z	0
Bit 5	SRC	SRC PD Drive Mode	Driven in PD	RW	Driven	Hi-Z	0
Bit 4		RESERVED					0
Bit 3	36,37	CPUCLK3 Stop Drive	Drive Mode in Stop	RW	Driven	Hi-Z	0
Bit 2	39,40	CPUCLK2 Stop Drive	Drive Mode in Stop	RW	Driven	Hi-Z	0
Bit 1	42,43	CPUCLK1 Stop Drive	Drive Mode in Stop	RW	Driven	Hi-Z	0
Bit 0	45,46	CPUCLK0 Stop Drive	Drive Mode in Stop	RW	Driven	Hi-Z	0

**SMBus Table: Test Mode and FS Readback Register**

Byte 6	Pin #	Name	Control Function	Type	0	1	PWD
Bit 7	-	Test Mode Selection	Test Mode Selection	RW	Hi-Z	REF/N	0
Bit 6	-	Test Clock Mode Entry	Test Mode	RW	Disable	Enable	0
Bit 5	-	RESERVED					0
Bit 4	54,55	REF Drive Strength	1X or 2X	RW	1X	2X	1
Bit 3	PCI, SRC	PCI_STOP Control	Stop non-free running PC and SRC clocks.	RW	Stop	Run	1
Bit 2	-	FS_C	FS_C readback	R	See 932s431 Functionality Table		Latch
Bit 1	-	FS_B	FS_B readback	R			Latch
Bit 0	-	FS_A	FS_A readback	R			Latch

**SMBus Table: Vendor & Revision ID Register**

Byte 7	Pin #	Name	Control Function	Type	0	1	PWD
Bit 7	-	RID3	REVISION ID (0 for A rev)	R	-	-	0
Bit 6	-	RID2		R	-	-	0
Bit 5	-	RID1		R	-	-	0
Bit 4	-	RID0		R	-	-	0
Bit 3	-	VID3	VENDOR ID	R	-	-	0
Bit 2	-	VID2		R	-	-	0
Bit 1	-	VID1		R	-	-	0
Bit 0	-	VID0		R	-	-	1



SMBus Table: Byte Count Register

Byte 8	Pin #	Name	Control Function	Type	0	1	PWD
Bit 7	-	BC7	Byte Count Programming b(7:0)	RW	Writing to this register will configure how many bytes will be read back, default is 8 bytes. (0 to 7)		0
Bit 6	-	BC6		RW			0
Bit 5	-	BC5		RW			0
Bit 4	-	BC4		RW			0
Bit 3	-	BC3		RW			0
Bit 2	-	BC2		RW			1
Bit 1	-	BC1		RW			1
Bit 0	-	BC0		RW			1

SMBus Table: Device ID Register

Byte 9	Pin #	Name	Control Function	Type	0	1	PWD
Bit 7		DID7	Device ID (3B hex)	R	-	-	0
Bit 6		DID6		R	-	-	0
Bit 5		DID5		R	-	-	1
Bit 4		DID4		R	-	-	1
Bit 3		DID3		R	-	-	1
Bit 2		DID2		R	-	-	0
Bit 1		DID1		R	-	-	1
Bit 0		DID0		R	-	-	1

SMBus Table: M/N Programming & Control Register

Byte 10	Pin #	Name	Control Function	Type	0	1	PWD
Bit 7	-	M/N_EN	CPU and SRC M/N Programming Enable	RW	Disable	Enable	0
Bit 6	CPU	CPU_STOP Control	Stop non-free running PC and SRC clocks.	RW	Stop	Run	1
Bit 5	-	RESERVED					0
Bit 4	-	RESERVED					0
Bit 3	SRC, PCI	SRC Alternate Frequency (96% of Nominal)	Set SRC = 96 MHz and PCI = 32 MHz Only active if Byte 10, bit 2 = 1	RW	Normal	Alternate Frequency	0
Bit 2	CPU	CPU Alternate Frequency (96% of Nominal) Only active if latched frequency is 166 MHz or 333 MHz.	Set alternate CPU frequency: 166 MHz to 160 MHz 333 MHz to 320 MHz	RW	Normal	Alternate Frequency	0
Bit 1	54	REF1 Drive Strength	1X or 2X	RW	See REF Drive Strength Functionality Table		1
Bit 0	55	REF0 Drive Strength	1X or 2X	RW			1



SMBus Table: CPU Frequency Control Register

Byte 11	Pin #	Name	Control Function	Type	0	1	PWD
Bit 7	-	CPU N Div8	N Divider Prog bit 8	RW	The decimal representation of M and N Divider in Byte 11 and 12 will configure the CPU VCO frequency. Default at power up = latch-in or Byte 0 Rom table. VCO Frequency = 14.318 x [NDiv(9:0)+8] / [MDiv(5:0)+2]		X
Bit 6	-	CPU N Div9	N Divider Prog bit 9	RW			X
Bit 5	-	CPU M Div5	M Divider Programming bit (5:0)	RW			X
Bit 4	-	CPU M Div4		RW			X
Bit 3	-	CPU M Div3		RW			X
Bit 2	-	CPU M Div2		RW			X
Bit 1	-	CPU M Div1		RW			X
Bit 0	-	CPU M Div0		RW			X

SMBus Table: CPU Frequency Control Register

Byte 12	Pin #	Name	Control Function	Type	0	1	PWD
Bit 7	-	CPU N Div7	N Divider Programming Byte12 bit(7:0) and Byte11 bit(7:6)	RW	The decimal representation of M and N Divider in Byte 11 and 12 will configure the CPU VCO frequency. Default at power up = latch-in or Byte 0 Rom table. VCO Frequency = 14.318 x [NDiv(9:0)+8] / [MDiv(5:0)+2]		X
Bit 6	-	CPU N Div6		RW			X
Bit 5	-	CPU N Div5		RW			X
Bit 4	-	CPU N Div4		RW			X
Bit 3	-	CPU N Div3		RW			X
Bit 2	-	CPU N Div2		RW			X
Bit 1	-	CPU N Div1		RW			X
Bit 0	-	CPU N Div0		RW			X

SMBus Table: CPU Spread Spectrum Control Register

Byte 13	Pin #	Name	Control Function	Type	0	1	PWD
Bit 7	-	CPU SSP7	Spread Spectrum Programming bit(7:0)	RW	These Spread Spectrum bits in Byte 13 and 14 will program the spread percentage of CPU		X
Bit 6	-	CPU SSP6		RW			X
Bit 5	-	CPU SSP5		RW			X
Bit 4	-	CPU SSP4		RW			X
Bit 3	-	CPU SSP3		RW			X
Bit 2	-	CPU SSP2		RW			X
Bit 1	-	CPU SSP1		RW			X
Bit 0	-	CPU SSP0		RW			X

SMBus Table: CPU Spread Spectrum Control Register

Byte 14	Pin #	Name	Control Function	Type	0	1	PWD
Bit 7	-	Reserved					0
Bit 6	-	CPU SSP14	Spread Spectrum Programming bit(14:8)	RW	These Spread Spectrum bits in Byte 13 and 14 will program the spread percentage of CPU		X
Bit 5	-	CPU SSP13		RW			X
Bit 4	-	CPU SSP12		RW			X
Bit 3	-	CPU SSP11		RW			X
Bit 2	-	CPU SSP10		RW			X
Bit 1	-	CPU SSP9		RW			X
Bit 0	-	CPU SSP8		RW			X



SMBus Table: SRC/PCI Frequency Control Register

Byte 15	Pin #	Name	Control Function	Type	0	1	PWD
Bit 7	-	SRC N Div8	N Divider Prog bit 8	RW	The decimal representation of M and N Divider in Byte 15 and 16 will configure the SRC VCO frequency. Default at power up = latch-in or Byte 0 Rom table. VCO Frequency = 14.318 x [NDiv(9:0)+8] / [MDiv(5:0)+2]		X
Bit 6	-	SRC N Div9	N Divider Prog bit 9	RW			X
Bit 5	-	SRC M Div5	M Divider Programming bits	RW			X
Bit 4	-	SRC M Div4		RW			X
Bit 3	-	SRC M Div3		RW			X
Bit 2	-	SRC M Div2		RW			X
Bit 1	-	SRC M Div1		RW			X
Bit 0	-	SRC M Div0		RW			X

SMBus Table: SRC/PCI Frequency Control Register

Byte 16	Pin #	Name	Control Function	Type	0	1	PWD
Bit 7	-	SRC N Div7	N Divider Programming b(7:0)	RW	The decimal representation of M and N Divider in Byte 15 and 16 will configure the SRC VCO frequency. Default at power up = latch-in or Byte 0 Rom table. VCO Frequency = 14.318 x [NDiv(9:0)+8] / [MDiv(5:0)+2]		X
Bit 6	-	SRC N Div6		RW			X
Bit 5	-	SRC N Div5		RW			X
Bit 4	-	SRC N Div4		RW			X
Bit 3	-	SRC N Div3		RW			X
Bit 2	-	SRC N Div2		RW			X
Bit 1	-	SRC N Div1		RW			X
Bit 0	-	SRC N Div0		RW			X

SMBus Table: SRC/PCI Spread Spectrum Control Register

Byte 17	Pin #	Name	Control Function	Type	0	1	PWD
Bit 7			RESERVED				X
Bit 6			RESERVED				X
Bit 5			RESERVED				X
Bit 4			RESERVED				X
Bit 3			RESERVED				X
Bit 2			RESERVED				X
Bit 1			RESERVED				X
Bit 0			RESERVED				X

SMBus Table: SRC/PCI Spread Spectrum Control Register

Byte 18	Pin #	Name	Control Function	Type	0	1	PWD
Bit 7			RESERVED				X
Bit 6			RESERVED				X
Bit 5			RESERVED				X
Bit 4			RESERVED				X
Bit 3			RESERVED				X
Bit 2			RESERVED				X
Bit 1			RESERVED				X
Bit 0			RESERVED				X



SMBus Table: CPU Programmable Output Divider Register

Byte 19	Pin #	Name	Control Function	Type	0	1	PWD
Bit 7	-	CPUDiv3	CPU Divider Ratio Programming Bits	RW	See CPU, SRC and PCI Divider Ratios Table		X
Bit 6	-	CPUDiv2		RW			X
Bit 5	-	CPUDiv1		RW			X
Bit 4	-	CPUDiv0		RW			X
Bit 3			RESERVED				X
Bit 2			RESERVED				X
Bit 1			RESERVED				X
Bit 0			RESERVED				X

SMBus Table: SRC and PCI Programmable Output Divider Register

Byte 20	Pin #	Name	Control Function	Type	0	1	PWD
Bit 7	-	PCIDiv3	PCI Divider Ratio Programming Bits	RW	See CPU, SRC and PCI Divider Ratios Table		X
Bit 6	-	PCIDiv2		RW			X
Bit 5	-	PCIDiv1		RW			X
Bit 4	-	PCIDiv0		RW			X
Bit 3	-	SRC_Div3	SRC_Divider Ratio Programming Bits	RW	See CPU, SRC and PCI Divider Ratios Table		X
Bit 2	-	SRC_Div2		RW			X
Bit 1	-	SRC_Div1		RW			X
Bit 0	-	SRC_Div0		RW			X

SMBusTable: Test Byte Register

Byte 21	Test	Test Function	Type	Test Result	PWD
Bit 7		ICS ONLY TEST	RW	Reserved	0
Bit 6		ICS ONLY TEST	RW	Reserved	0
Bit 5		ICS ONLY TEST	RW	Reserved	0
Bit 4		ICS ONLY TEST	RW	Reserved	0
Bit 3		ICS ONLY TEST	RW	Reserved	0
Bit 2		ICS ONLY TEST	RW	Reserved	0
Bit 1		ICS ONLY TEST	RW	Reserved	0
Bit 0		ICS ONLY TEST	RW	Reserved	0

Note: Do NOT write to Bit 21. Erratic device operation will result!



### REF Drive Strength Functionality

Byte6, bit 4	Byte 10, bit 1	Byte 10, bit 0	REF1	REF0
0	X	X	1x	1x
1	0	0	1x	1x
1	0	1	1x	2x
1	1	0	2x	1x
<b>1</b>	<b>1</b>	<b>1</b>	<b>2x</b>	<b>2x</b>

### CPU, SRC and PCI Divider Ratios

	Div(3:0)	Divider
0	0000	2
1	0001	3
2	0010	5
3	0011	15
4	0100	4
5	0101	6
6	0110	10
7	0111	30
8	1000	8
9	1001	12
10	1010	20
11	1011	60
12	1100	16
13	1101	24
14	1110	40
15	1111	120

### PD, Power Down

PD is an asynchronous active high input used to shut off all clocks cleanly prior to system power down. When PD is asserted, all clocks will be driven low before turning off the VCO. All clocks will start without glitches when PD is de-asserted.

PD	CPU	CPU #	SRC	SRC#	PCIF/PCI	USB	REF	Note
0	Normal	Normal	Normal	Normal	33MHz	48MHz	14.318MHz	1
1	Iref * 2 or Float	Float	Iref * 2 or Float	Float	Low	Low	Low	1

Notes:

1. Refer to SMBus Byte 4 for additional information.

### PD Assertion

PD should be sampled high by 2 consecutive CPU# rising edges before stopping clocks. All single ended clocks will be held low on their next high to low transition.

All differential clocks will be held high on the next high to low transition of the complimentary clock. If the control register determining to drive mode is set to 'tri-state', the differential pair will be stopped in tri-state mode, undriven.

When the drive mode corresponding to the CPU or SRC clock of interest is set to '0' the true clock will be driven high at 2 x Iref and the complementary clock will be tristated. If the control register is programmed to '1' both clocks will be tristated. See SMBus Bytes 4 and 5 for additional information.

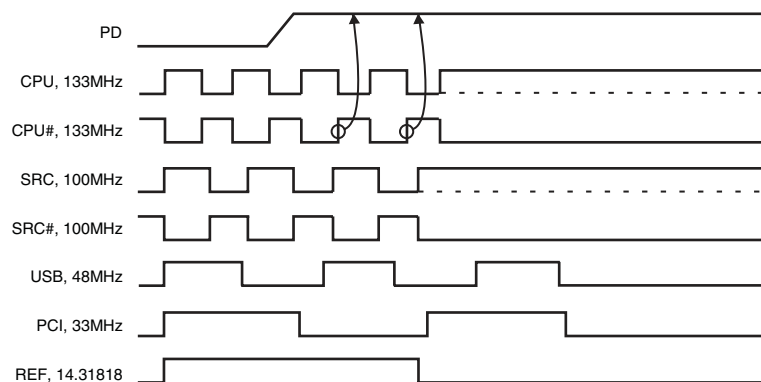

**PD De-assertion**

The time from the de-assertion of PD or until power supply ramps to get stable clocks will be less than 1.8ms. If the drive mode control bit for PD tristate is programmed to '1' the stopped differential pair must first be driven high to a minimum of 200mV in less than 300µs of PD deassertion.

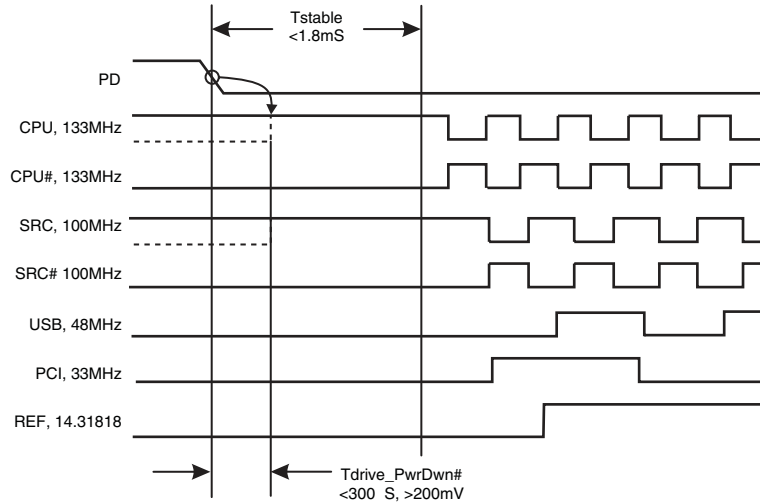

**Test Clarification Table**

Comments	HW		SW		OUTPUT
	FS_C/TEST_SEL	FS_B/TEST_MODE	TEST ENTRY BIT	REF/N or HI-Z	
	HW PIN	HW PIN	B6b6	B6b7	
	0	X	0	X	NORMAL
Power-up w/ TEST_SEL = 1 to enter test mode	1	0	X	0	HI-Z
Cycle power to disable test mode	1	0	X	1	REF/N
FS_C./TEST_SEL -->3-level latched input	1	1	X	0	REF/N
If power-up w/ V>2.0V (-0.3V) then use TEST_SEL	1	1	X	1	REF/N
If power-up w/ V<2.0V (-0.3V) then use FS_C					
FS_B/TEST_MODE -->low Vth input					
TEST_MODE is a real time input					
If TEST_SEL HW pin is 0 during power-up, test mode can be invoked through B6b6.	0	X	1	0	HI-Z
If test mode is invoked by B6b6, only B6b7 is used to select HI-Z or REF/N	0	X	1	1	REF/N
FS_B/TEST_Mode pin is not used.					
Cycle power to disable test mode, one shot control					
B6b6: 1= ENTER TEST MODE, Default = 0 (NORMAL OPERATION)					
B6b7: 1= REF/N, Default = 0 (HI-Z)					

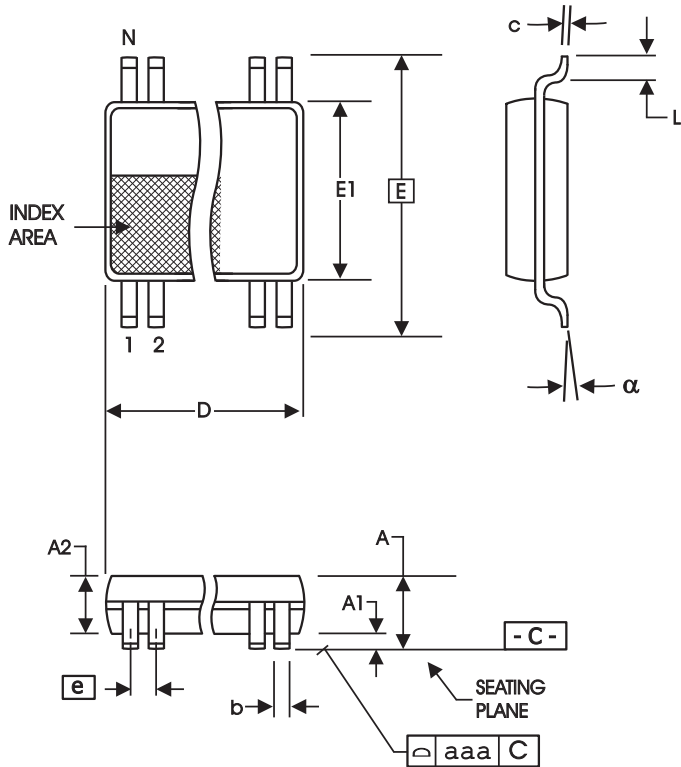

**6.10 mm. Body, 0.50 mm. Pitch TSSOP**  
(240 mil) (20 mil)

SYMBOL	In Millimeters COMMON DIMENSIONS		In Inches COMMON DIMENSIONS	
	MIN	MAX	MIN	MAX
A	--	1.20	--	.047
A1	0.05	0.15	.002	.006
A2	0.80	1.05	.032	.041
b	0.17	0.27	.007	.011
c	0.09	0.20	.0035	.008
D	SEE VARIATIONS		SEE VARIATIONS	
E	8.10 BASIC		0.319 BASIC	
E1	6.00	6.20	.236	.244
e	0.50 BASIC		0.020 BASIC	
L	0.45	0.75	.018	.030
N	SEE VARIATIONS		SEE VARIATIONS	
alpha	0°	8°	0°	8°
aaa	--	0.10	--	.004

**VARIATIONS**

N	D mm.		D (inch)	
	MIN	MAX	MIN	MAX
56	13.90	14.10	.547	.555

Reference Doc.: JEDEC Publication 95, MO-153

10-0039

**Ordering Information**

Part / Order Number	Shipping Packaging	Package	Temperature
932S431AGLF	Tubes	56-pin TSSOP	0 to +70°C
932S431AGLFT	Tape and Reel	56-pin TSSOP	0 to +70°C

"LF" suffix to the part number are the Pb-Free configuration and are RoHS compliant.  
"A" denotes the revision designator (will not correlate to datasheet revision).



---

---

### Revision History

Rev.	Issue Date	Description	Page #
0.1	12/10/2007	1. Initial Release	-
0.2	7/8/2008	Romoved SSOP Ordering Information.	-
0.3	9/17/2008	Updated electrical characteristics, PPM and clock period data	Various
0.4	10/22/2009	Updated Datasheet title (added QPI) and Key Specification bullets	1
A	11/12/2009	Released to final.	