

Description

The 92HD73E codec is a low power optimized, high fidelity, 10-channel audio codec compatible with Intel's High Definition (HD) Audio Interface. The 92HD73E codec provides stereo 24-bit resolution with sample rates up to 192kHz. Dual SPDIF provides connectivity to consumer electronic equipment that is WLP compliant. The 92HD73E provides high quality, HD Audio capability to multimedia notebook and desktop PC applications.

Features

- **10 Channels (5 stereo DACs and 2 stereo ADCs) with 24-bit resolution**
 - Supports full-duplex 7.1 audio and simultaneous VoIP
- **Microsoft WLP premium logo compliant**
- **Optimized and flexible power management with pop/click mitigation**
- **SPDIF**
 - 48QFP package supports 2 independent S/PDIF Output converters for WLP compliant HDMI/SPDIF support
 - 40QFN package supports a single SPDIF Out
 - Both packages support SPDIF Input
- **HDA signaling**
 - 48QFP package support for 1.5V and 3.3V with runtime selection
 - 40QFN package supports 3.3V only
- **3 adjustable VREF Out pins for microphone bias**
- **High performance analog mixer**
- **9 stereo analog ports with presence detect capability**
- **Digital and Analog PC Beep to all outputs**
- **3 Integrated headphone amps**
- **Sample rates up to 192kHz**
- **Additional Features on 48QFP package**
 - Two-pin volume up/down control
 - Digital microphone input (mono, stereo, or quad array)
 - 4th adjustable VREF Out
 - Additional 5 GPIOs
- **Package Options**
 - 48-pin QFP RoHS package
 - 48-pin QFP RoHS package, Industrial Temp
 - 40-pin QFN RoHS package

Software Support

- **Intuitive IDT HD Sound graphical user interface that allows configurability and preference settings**
- **12 band fully parametric equalizer**
- **Constant, system-level effects tuned to optimize a particular platform can be combined with user-mode "presets" tailored for specific acoustical environments and applications**
- **System-level effects automatically disabled when external audio connections made**
- **Dynamics Processing**
- **Enables improved voice articulation**
- **Compressor/limiter allows higher average volume level without resonances or damage to speakers.**
- **IDT Vista APO wrapper**
- **Enables multiple APOs to be used with the IDT Driver**
- **Microphone Beam Forming, Acoustic Echo Cancellation, and Noise Suppression**
- **Dynamic Stream Switching**
- **Improved multi-streaming user experience with less support calls**
- **Broad 3rd party branded software including Creative, Dolby, DTS, and SRS**

TABLE OF CONTENTS

1. DESCRIPTION	4
1.1. Overview	4
1.2. Orderable Part Numbers	4
1.3. Detailed Description	5
2. CHARACTERISTICS	22
2.1. Electrical Specifications	22
2.2. 92HD73E Analog Performance Characteristics	23
3. PORT CONFIGURATIONS	27
4. FUNCTIONAL BLOCK DIAGRAMS	28
4.1. 48QFP	28
4.2. 40QFN	29
4.3. Widget Information and Supported Command Verbs	30
4.4. Widget List	31
4.5. Pin Configuration Default Register Settings	32
5. WIDGET INFORMATION	34
5.1. Root Node (NID = 00)	35
5.2. AFG Node (NID = 01)	36
5.3. Port A Node (NID = 0A)	53
5.4. PortB Node (NID = 0B)	60
5.5. Port C Node (NID = 0C)	67
5.6. Port D Node (NID = 0D)	74
5.7. PortE Node (NID = 0E)	81
5.8. PortF Node (NID = 0F)	88
5.9. PortG Node (NID = 10)	93
5.10. PortH Node (NID = 11)	101
5.11. PortI Node (NID = 12)	108
5.12. DMic0 Node (NID = 13)	113
5.13. DMic1 Node (NID = 14)	117
5.14. DAC0 Node (NID = 15)	122
5.15. DAC1 Node (NID = 16)	126
5.16. DAC2 Node (NID = 17)	131
5.17. DAC3 Node (NID = 18)	135
5.18. DAC4 Node (NID = 19)	140
5.19. ADC0 Node (NID = 1A)	144
5.20. ADC1 Node (NID = 1B)	149
5.21. DigBeep Node (NID = 1C)	153
5.22. Mixer Node (NID = 1D)	156
5.23. MixerOutVol Node (NID = 1E)	164
5.24. VolumeKnob Node (NID = 1F)	167
5.25. ADC0Mux Node (NID = 20)	171
5.26. ADC1Mux Node (NID = 21)	175
5.27. Dig0Pin Node (NID = 22)	180
5.28. Dig1Pin Node (NID = 23)	185
5.29. Dig2Pin Node (NID = 24)	190
5.30. SPDIFOut0 Node (NID = 25)	196
5.31. SPDIFOut1 Node (NID = 26)	202
5.32. SPDIFIn Node (NID = 27)	208
5.33. InPort0Mux Node (NID = 28)	219
5.34. InPort1Mux Node (NID = 29)	221
5.35. InPort2Mux Node (NID = 2A)	223
5.36. InPort3Mux Node (NID = 2B)	226
6. DISCLAIMER	228
7. PINOUTS	229
7.1. 48QFP	229
7.2. 40QFN	232
8. PACKAGE OUTLINE AND PACKAGE DIMENSIONS	234
8.1. 48QFP Package	234

92HD73E

Ten Channel HD Audio Codec

8.2. 40QFN Package	235
8.3. Standard Reflow Profile Data	235
8.4. Pb Free Process - Package Classification Reflow Temperatures	236
9. DOCUMENT REVISION HISTORY	237

LIST OF FIGURES

Figure 1. Multi-channel capture	11
Figure 2. Multi-channel timing diagram	11
Figure 3. EAPD	14
Figure 4: Mono Digital Microphone (data is ported to both left and right channels)	16
Figure 5: Stereo Digital Microphone Configuration	16
Figure 6: Quad Digital Microphone Configuration	17
Figure 7: External Volume Control Circuit	21
Figure 8. Port Configuration	27
Figure 9. 48QFP Functional Block Diagram	28
Figure 10. 40QFN Functional Block Diagram	29
Figure 11. Widget Diagram	30
Figure 12. 48QFP Pin Assignment	229
Figure 13. 40QFN Pin Assignment	232
Figure 14. 48QFP Package Drawing	234
Figure 15. 40QFN Package Drawing	235
Figure 16. Solder Reflow Profile	236

LIST OF TABLES

Table 1. Port Functionality	5
Table 2. Analog I/O Port Behavior	6
Table 4. SPDIF OUT 0 (Pin 48) Behavior	7
Table 5. SPDIF OUT 1 (Pin 40) Behavior	7
Table 6. Input Multiplexers	8
Table 7. Function state vs. AFG power state	9
Table 10. EAPD Behavior	13
Table 11. Valid Digital Mic Configurations	15
Table 12. DMIC_CLK and DMIC_0,1 Operation During Power States	15
Table 13. GPIO Pin mapping	19
Table 14. Electrical Specification: Maximum Ratings	22
Table 15. Recommended Operating Conditions	22
Table 16. 92HD73E Analog Performance Characteristics	23
Table 17. High Definition Audio Widget	31
Table 18. Pin Configuration Default Settings	32
Table 19. Command Format for Verb with 4-bit Identifier	34
Table 20. Command Format for Verb with 12-bit Identifier	34
Table 21. Solicited Response Format	34
Table 22. Unsolicited Response Format	34
Table 23. 48QFP Pin Table	230
Table 24. 40QFN Pin Table	233
Table 25. Standard Reflow Profile	235
Table 26. Pb-Free Process Reflow	236

1. DESCRIPTION**1.1. Overview**

The 92HD73E is a high fidelity, 10-channel audio codec compatible with the Intel High Definition (HD) Audio Interface. The 92HD73E codec provides high quality, HD Audio capability to desktop and multi-media notebook.

The 92HD73E is designed to meet or exceed premium logo requirements for Microsoft's Windows Logo Program (WLP) 3.09 and revisions 4 as indicated in WLP 3.09.

The 92HD73E provides stereo 24-bit, full duplex resolution supporting sample rates up to 192kHz by the DAC and ADC. 92HD73E SPDIF outputs support sample rates of 192kHz, 176.4kHz, 96kHz, 88.2kHz, 48kHz, and 44.1kHz. 92HD73E SPDIF input supports sample rates of 96kHz, 88.2kHz, 48kHz, and 44.1kHz. Additional sample rates are supported by the driver software.

The 92HD73E supports a wide range of desktop and consumer 8/10 channel configurations. The 2 independent SPDIF output interfaces provides connectivity to Consumer Electronic equipment like Dolby Digital decoders, powered speakers, mini disk drives or to a home entertainment system. Simultaneous HDMI and SPDIF output is possible.

MIC inputs can be programmed with 0/10/20/30dB boost. For more advanced configurations, the 92HD73E has 8 General Purpose I/O (GPIO) in the 48QFP package.

The port presence detect capabilities allow the codecs to detect when audio devices are connected to the codec. Load impedance sensing helps identify attached peripherals for easy set-up and a better user experience. The fully parametric IDT SoftEQ can be initiated upon headphone jack insertion and removal for protection of notebook speakers.

The 92HD73E operates with a 3.3V digital supply and a 5V analog supply. It can also work with 1.5V and 3.3V HDA signaling; the correct signalling level is selected dynamically based on the power supply voltage on the DVDD-IO pin in the 48QFP package. The 40QFN package allows for 3.3V HDA signalling.

1.2. Orderable Part Numbers

92HD73E1X5PRGXB2X* 92HD73E1X5PRGXC1X	48QFP
92HD73E1T5PRGIC1X	48QFP, Industrial Temp
92HD73E2X5NDGXC1X	40QFN

* limited quantities of the B2 available, contact IDT sales.
Add an "8" to the end for tape and reel delivery.

1.3. Detailed Description

1.3.1. Port Functionality

Multi-function (Input / output) ports allow for the highest possible flexibility. 8 bi-directional ports (3 headphone capable) support a wide variety of consumer desktop and mobile system use models.

Port	Input	Output	Headphone	Mic Bias (Vref pin)	Input boost amp ¹	CD (pseudo differential)
A	Yes	Yes	Yes	Yes	Yes	
B	Yes	Yes	Yes	Yes	Yes	
C	Yes	Yes		Yes	Yes	
D	Yes	Yes	Yes		Yes	
E	Yes	Yes		Yes	Yes	
F	Yes	Yes			Yes	
G	Yes	Yes			Yes	
H	Yes	Yes			Yes	
CD (Port I)	Yes					Yes
SPDIF_OUT0		Yes				
SPDIF_OUT1		Yes				
SPDIF_IN	Yes					
DMIC0	Yes				Yes	
DMIC1	Yes				Yes	

Table 1. Port Functionality

Note¹: 40dB boost requires using the IDT driver. When the 40dB mic boost feature is enabled, additional gain increases greater than 6dB may result in significant audio quality degradation of the microphone audio input. In particular, when the 40dB MIC boost is active, the SNR, THD+N and DC offset will significantly degrade regardless of the input signal level.

1.3.2. Port Characteristics

Universal (Bi-directional) jacks are supported on all ports except the CD input. Ports A, B, and D are designed to drive a set of 32 ohm (nominal) headphones or a 10K (nominal) load with on board shunt resistance as low as 20K ohms (typical - used to maintain coupling CAP bias.) Line Level outputs are intended to drive an external 10K speaker load (nominal) and an on board shunt resistor of 20K-47K (nominal). However, applications may support load impedances of 5K ohms and above. Input ports are 47K (nominal) at the pin.

DAC full scale output and intended full scale input levels are 1V rms. Line output ports and Headphone output ports on 92HD73E may be configured for +3dBV full scale output levels by using a vendor specific verb.

Output ports are always on to prevent pops/clicks associated with charging and discharging output coupling capacitors. This maintains proper bias on output coupling caps even in D3 as long as AVDD is available. Unused ports should be left unconnected. When updating existing designs to use the 92HD73E, ensure that there are no conflicts between the output ports on 92HD73E and existing circuitry.

AFG Power State	Input Enable	Output Enable	Mute	Port Behavior
D0-D2	1	1	-	Not allowed. Port becomes input.
	1	0	-	Active - port enabled as input
	0	1	0	Active - port enabled as output
	0	1	1	Mute - port enabled as output but drives silence
	0	0	-	Inactive - Port keeps coupling caps charged (same as mute.)
D3		-	-	Inactive (lower power) - Port keeps output coupling caps charged but consumes less power.

Table 2. Analog I/O Port Behavior

1.3.3. Jack Detect

Plugs inserted to a jack on Ports A, B, C, & D are detected using SENSE_A. Plugs inserted to a jack on Ports E, F, G, and H are detected using SENSE_B. The following table summarizes the proper resistor tolerances for different analog supply voltages.

SENSE_C, is different from SENSE_A and SENSE_B. Because SENSE_C only determines the presence of a plug for the CD port (port I), SENSE_C is a simple digital input pin referenced to the analog supply. An internal pull-up resistor is provided. No external resistors are needed (jack switch shorts to ground when a plug is inserted.) If external components are added, or if the pin is driven by a logic gate, care should be taken to ensure that the pin voltage is above 70% of AVDD when no plug is in the jack and less than 30% AVDD when a plug is inserted.

AVdd Nominal Voltage (+/- 5%)	Resistor Tolerance SENSE_A (If port D used)	Resistor Tolerance SENSE_A (If port D is not used)	Resistor Tolerance SENSE_B (If port H used)	Resistor Tolerance SENSE_B (If port H is not used)
5V	1%	1%	1%	1%
4.75V	1%	1%	1%	1%
4V	0.50%	1%	0.50%	1%
3.3V	0.10%	1%	0.10%	1%

Table 3: SENSE Resistor Tolerance

See reference design for more information on Jack Detect implementation.

1.3.4. SPDIF Output

All SPDIF Outputs can operate at 44.1kHz, 48kHz, 88.2kHz, 96kHz, 176.4KHz, and 192KHz as defined in the Intel High Definition Audio Specification with resolutions up to 24 bits. This insures compatibility with all consumer audio gear and allows for convenient integration into home theater systems and media center PCs.

A second independent SPDIF Output is provided as an option for WLP compliant HDMI and SPDIF outputs, available only of 48QFP package. Its function is identical to the primary SPDIF output.

Note: Peak to peak jitter is currently limited to less than 4.5nS (half of the internal master clock cycle) which does not meet the IEC-60958-3 0.05UI requirement at 192KHz.

92HD73E

Ten Channel HD Audio Codec

The two SPDIF output converters can not be aligned in phase with the DACs. Even when attached to the same stream, the two SPDIF output converters may be misaligned with respect to their frame boundaries.

SPDIF Outputs on pins 48 and 40 are outlined in tables below. Pin 47 behavior table resides in the EAPD section

AFG Power State	RESET#	Output Enable	Converter Dig Enable	Stream ID	Pin Behavior
D0-D3	Asserted (Low)	-	-	-	Hi-Z (internal pull-down enabled) immediately after power on, otherwise the previous state is retained until the rising edge of RESET#
D0	De-Asserted (High)	Disabled	-	-	Hi-Z (internal pull-down enabled)
	De-Asserted (High)	Enabled	Disabled	-	Active - Pin drives 0 (internal pull-down NA)
	De-Asserted (High)	Enabled	Enabled	0	Active - Pin drives SPDIF-format, but data is zeroes (internal pull-down NA)
	De-Asserted (High)	Enabled	Enabled	1-15	Active - Pin drives SPDIFOut0 data (internal pull-down NA)
D1-D2	De-Asserted (High)	Disabled	-	-	Hi-Z (internal pull-down enabled)
	De-Asserted (High)	Enabled	-	-	Active - Pin drives 0 (internal pull-down NA)
D3	De-Asserted (High)	-	-	-	Hi-Z (internal pull-down enabled)

Table 4. SPDIF OUT 0 (Pin 48) Behavior

AFG Power State	RESET#	GPIO 3 Enable	Output Enable	Converter Dig Enable	Stream ID	Pin Behavior
D0-D3	Asserted (Low)	-	-	-	-	Hi-Z (internal pull-down enabled) immediately after power on, otherwise the previous state is retained until the rising edge of RESET#
D0-D3	De-Asserted (High)	Enabled	-	-	-	Active - Pin reflects GPIO7 configuration (internal pull-up enabled)
D0	De-Asserted (High)	Disabled	Disabled	-	-	Hi-Z (internal pull-down enabled)
	De-Asserted (High)	Disabled	Enabled	Disabled	-	Active - Pin drives 0 (internal pull-down enabled)
	De-Asserted (High)	Disabled	Enabled	Enabled	0	Active - Pin drives SPDIF-format, but data is zeroes (internal pull-down enabled)
	De-Asserted (High)	Disabled	Enabled	Enabled	1-15	Active - Pin drives SPDIFOut1 data (internal pull-down enabled)

Table 5. SPDIF OUT 1 (Pin 40) Behavior

92HD73E

Ten Channel HD Audio Codec

AFG Power State	RESET#	GPIO 3 Enable	Output Enable	Converter Dig Enable	Stream ID	Pin Behavior
D1-D2	De-Asserted (High)	Disabled	Disabled	-	-	Hi-Z (internal pull-down enabled)
	De-Asserted (High)	Disabled	Enabled	-	-	Active - Pin drives 0 (internal pull-down NA)
D3	De-Asserted (High)	Disabled	-	-	-	Hi-Z (internal pull-down enabled)

Table 5. SPDIF OUT 1 (Pin 40) Behavior

1.3.5. SPDIF Input

SPDIF IN can operate at 44.1 KHz, 48 KHz, 88.2 KHz or 96 KHz, and implements internal Jack Sensing.

A sophisticated digital PLL allows automatic rate detection and accurate data recovery. The ability to directly accept consumer SPDIF voltage levels eliminates the need for costly external receiver ICs. Advanced features such as record-slot-select and SPDIF_IN routing to the DAC allow for simultaneous record and play.

1.3.6. Analog Mixer

An analog mixer is available on the 92HD73E. The mixer supports independent gain (-34.5 to +12dB in 1.5dB steps) on each input as well as independent mutes on each input. A master volume follows mixing and provides gain from -46.5dB to 0dB in 1.5dB steps.

The following inputs are available:

- CD
- Analog PC_Beep
- Inport0_Mux
- Inport1_Mux
- Inport2_Mux
- Inport3_mux

1.3.7. Input Multiplexers

92HD73E implements 4 port input multiplexers. These multiplexers allow a preselection of one of four possible inputs:

Inport0_Mux	Inport1_Mux	Inport2_Mux	Inport3_mux
Port A	Port A	Port B	DAC 0
Port B	Port E	Port C	DAC 1
Port D	Port G	Port G	DAC 2
Port F	Port H	Port H	DAC 3

Table 6. Input Multiplexers

1.3.8. ADC Multiplexers

92HD73E implements 2 ADC input multiplexers. These multiplexers incorporate the ADC record gain function (0 to +22.5dB gain in 1.5dB steps) as an output amp and allow a preselection of one of 12 possible inputs:

- DMIC 0 (not on 40QFN)
- DMIC 1 (not on 40QFN)
- Mixer output
- CD input
- Ports A - H

1.3.9. Power Management

The HD Audio specification defines power states, power state widgets, and power state verbs. Power management is implemented at several levels. The Audio Function Group (AFG) and all converter widgets support the power state verb F05/705 (as well as the pin widget associated with pin 47.) Converter widgets are active in D0 and inactive in D1-D3.

The following table describes what functionality is active in each power state supported by the AFG.

Function	D0	D1 ¹	D2	D3	vendor specific
SPDIF Outputs	On	Off	Off	Off	-
SPDIF Inputs	On	Off	Off	Off	-
Digital Microphone inputs	On	Off	Off	Off	-
DAC	On	Off	Off	Off	-
D2S	On	Off	Off	Off	-
ADC	On	Off	Off	Off	-
ADC Volume Control	On	Off	Off	Off	-
Ref ADC	On	Off	Off	Off	-
Analog Clocks	On	Off	Off	Off	-
GPIO pins	On	On	On	On	-
VrefOut Pins	On	On	Off	Off	-
Input Boost	On	On	Off	Off	-
Analog mixer	On	On	Off	Off	-
Mixer Volumes	On	On	Off	Off	-
Analog PC_Beep	On	On	Off	Off	-
Digital PC_Beep	On	On	On	On	-
Lo Amp	On	On	On	Low Drive ²	Programmable
HP Amps	On	On	On	Low Drive ²	Programmable
VAG amp	On	On	On	Low Drive ³	Programmable
Port Sense	On	On	On	On ⁴	Programmable
Reference Bias generator	On	On	On	On	Programmable ⁵
Reference Bandgap core	On	On	On	On	Programmable ⁵
HD Audio-Link	On	On	On	On ⁶	-

Table 7. Function state vs. AFG power state

1.No DAC or ADC streams are active. Analog mixing and loop thru are supported.

2.VAG is kept active when ports are disabled or in D2/D3. Ports may be powered down using vendor specific verbs.

- 3.VAG is always ramped up and down gradually, except in the case of a sudden power removal. VAG is active in D2/D3 but in a low power state.
4. BITCLK must be active and both AVDD and DVDD must be available for Port Sense to operate.
5. Vendor specific bit for Ref Top controls VAG generator, Bandgap Reference, and Reference bias generator. Place part into D3 and power down all ports (using vendor specific verbs) before powering down Ref Top.
6. Obviously not active if BITCLK is not running (Controller in D3).

1.3.9.1. AFG D0

The AFG D0 state is the active state for the device. All functions are active if their power state (if they support power management at their node level) has been set to D0.

1.3.9.2. AFG D1

D1 is a lower power mode where all converter widgets are disabled. Analog mixer and port functions are active.

1.3.9.3. AFG D2

The D2 state further reduces power by disabling the mixer and port functions. The port amplifiers and internal references remain active to keep port coupling caps charged and the system ready for a quick resume to either the D1 or D0 state.

1.3.9.4. AFG D3

The D3-default state is available for HD Audio compliance. All converters are shut down. Port amplifiers and references are active but in a low power state to prevent pops. Resume times may be longer than those from D2, but still very fast to meet Intel low power goals.

The traditional use for D3 was as a transitional state before power was removed (D3 cold) before the system entered into standby, hibernate, or shut-down. To conserve power, Intel now promotes using D3 whenever there are no active streams or other activity that requires the part to consume full power. The system remains in S0 during this time. When a stream request or user activity requires the CODEC to become active, the driver will immediately transition the CODEC from D3 to D0. To enable this use model, the CODEC must resume within 10mS and not pop.

The default power state for the Audio Function Group after reset is D3-default

1.3.9.5. AFG D3 and vendor specific verbs

The programmable values, exposed via vendor-specific settings, are under the IDT Device Driver control for further power reduction.

1.3.10. Low-voltage HDA Signaling

The 92HD73E is compatible with either 1.5V or 3.3V HDA bus signaling; the voltage selection is done dynamically based on the input voltage of DVDD_IO on the 48QFP package. The 40QFN allows for 3.3V only.

When in 1.5V mode, the 92HD73E can correctly decode BITCLK, SYNC, RESET# and SDO as they operate at 1.5V; additionally it will drive SDI and SDO at 1.5V. None of the GPIOs are affected, as they always function at their nominal voltage (DVDD or AVDD).

1.3.11. Multi-channel capture

The capability to assign multiple ADC "Input Converters" to the same stream is supported to meet the microphone array requirements of Vista and future operating systems. Single converter streams are still supported and is done by assigning unique non zero Stream IDs to each converter. All cap-

ture devices (ADCs 0 and 1) may be used to create a multi-channel input stream. There are no restrictions regarding digital microphones. However, the SPDIF input can not be used with an ADC to create a 4-channel stream. SPDIF_In only supports stereo capture.

The ADC Converters can be associated with a single stream as long as the sample rate and the bits per sample are the same. The assignment of converter to channel is done using the “CnvtrID” widget and is restricted to even values. The ADC converters will always put out a stereo sample and therefore require 2 channels per converter.

The stream will not be generated unless all entries for the targeted converters are set identically, and the total number of assigned converter channels matches the value in the NmbrChan field. These are listed the “Multi-Converter Stream Critical Entries” table.

An example of a 4 Channel Steam with ADC0 supplying channels 0&1 and ADC1 supplying channels 2&3 is shown below. A 4 Channel stream can be created by assigning the same non-zero stream id “Strm= N” to both ADC0 and ADC1. The sample rates must be set the same and the number of channels must be set to 4 channels “NmbrChan = 0011”.

ADC1 CnvtrID	(NID = 0x08)	
	[3:0]	Ch = 2
ADC0 CnvtrID	(NID = 0x07)	
	[3:0]	Ch = 0

Table 8: Example channel mapping

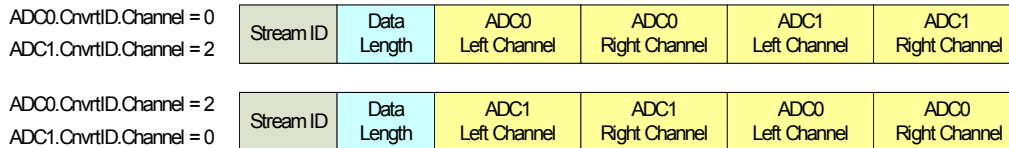

Figure 1. Multi-channel capture

The following figure describes the bus waveform for a 24-bit, 48KHz capture stream with ID set to 1.

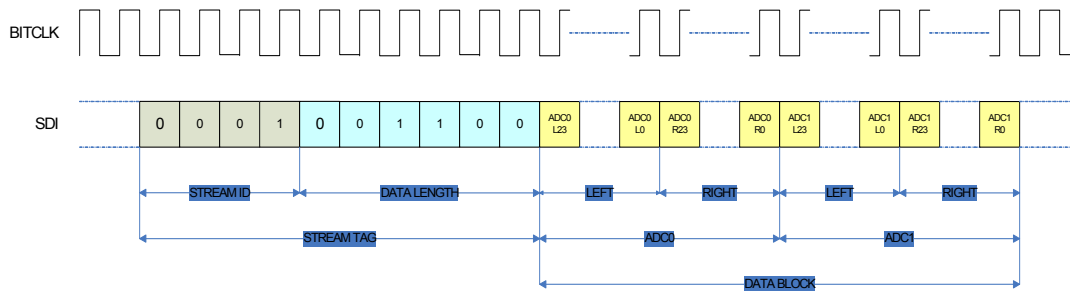

Figure 2. Multi-channel timing diagram

ADC[1:0] Cnvtr	Bit Number	Sub Field Name	Description
	[15]	StrmType	Stream Type (TYPE): 0: PCM 1: Non-PCM (not supported)
	[14]	FrmtSmpIRate	Sample Base Rate 0= 48kHz 1=44.1KHz
	[13:11]	SmpIRateMultp	Sample Base Rate Multiple 000=48kHz/44.1kHz or less 001= x2 010= x3 (not supported) 011= x4 100-111= Reserved
	[10:8]	SmpIRateDiv	Sample Base Rate Divisor 000= Divide by 1 001= Divide by 2 (not supported) 010= Divide by 3 (not supported) 011= Divide by 4 (not supported) 100= Divide by 5 (not supported) 101= Divide by 6 (not supported) 110= Divide by 7 (not supported) 111= Divide by 8 (not supported)
	[6:4]	BitsPerSmpl	Bits per Sample 000= 8 bits (not supported) 001= 16 bits 010= 20 bits 011= 24 bits 100-111= Reserved
	[3:0]	NmbrChan	Number of Channels Number of channels for this stream in each “sample block” of the “packets” in each “frame” on the link. 0000=1 channel (not supported) 0001 = 2 channels ... 1111= 16 channels.
ADC[1:0] CnvtrID	Bit Number	Sub Field Name	Description
	[7:4]	Strm	Software-programmable integer representing link stream ID used by the converter widget. By convention stream 0 is reserved as unused.
	[3:0]	Ch	Integer representing lowest channel used by converter. 0 and 2 are valid Entries If assigned to the same stream, one ADC must be assigned a value of 0 and the other ADC assigned a value of 2.

Table 9: Multi-Converter Stream Critical Entries.

1.3.12. EAPD

The EAPD pin also supports SPDIF_In and GPIO functions. The pin defaults to EAPD after power on reset and will remain in EAPD mode until either GPIO is enabled for pin 47 or the port I/O is enabled to support SPDIF. Although named External Amplifier Power Down (EAPD) by the HD Audio specification, this pin operates as an external amplifier power up signal. The EAPD value is reflected on the EAPD pin; a 1 causes the external amplifier to power up, and a 0 causes it to power down. When the EAPD value = 1, the EAPD pin must be placed in a state appropriate to the current power state of the associated Pin Widget even though the EAPD value may remain 1. The default state of this pin is 0 (driving low) and a Pull-down prevents the line from floating high when the part is in reset.

AFG Power State	RESET#	GPIO Enable	Input Enable	EAPD Power State	Pin Behavior
D0-D3	Asserted (Low)	-	-	-	Hi-Z (internal pull-down enabled) immediately after power on, otherwise the previous state is retained until the rising edge of RESET#
D0	De-Asserted (High)	Enabled	-	-	Active - Pin reflects GPIO0 configuration (internal pull-up enabled)
	De-Asserted (High)	Disabled	Enabled	-	Active - Pin is SPDIF_In
	De-Asserted (High)	Disabled	Disabled	D0-D1	Active - Pin drives the value of the EAPD bit (internal pull-down enabled)
	De-Asserted (High)	Disabled	Disabled	D2-D3	Hi-Z (internal pull-down enabled)
D1	De-Asserted (High)	Disabled	Enabled	-	Inactive - Pin configured as input, but SPDIF_In idle.
	De-Asserted (High)	Disabled	Disabled	D0-D1	Active - Pin drives the value of the EAPD bit (internal pull-down enabled)
	De-Asserted (High)	Disabled	Disabled	D2-D3	Hi-Z (internal pull-down enabled)
D2	De-Asserted (High)	Disabled	-	D0-D3	Hi-Z (internal pull-down enabled)
D3	De-Asserted (High)	Disabled	-	D0-D3	Hi-Z (internal pull-down enabled)

Table 10. EAPD Behavior

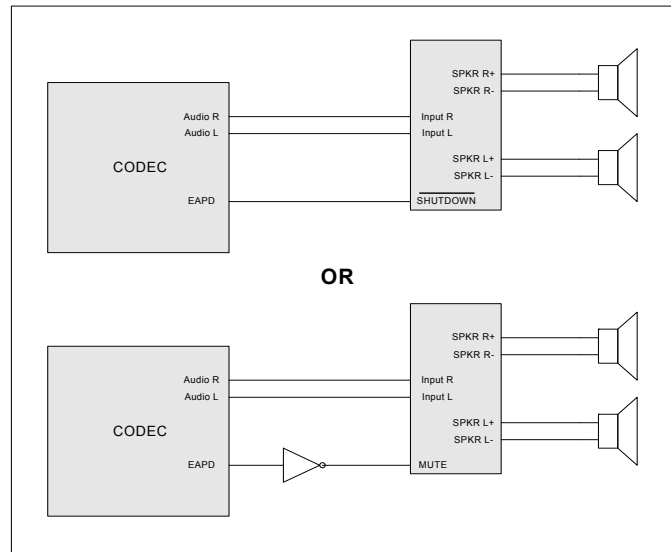

Figure 3. EAPD

1.3.13. Digital Microphone Support (on 48QFP package)

The digital microphone interface permits connection of a digital microphone(s) to the CODEC via the DMIC0, DMIC1, and DMIC_CLK 3-pin interface. The DMIC0 and DMIC1 signals are inputs that carry individual channels of digital Mic data to the ADC. In the event that a single microphone is used, the data is ported to both ADC channels.

The DMIC_CLK output is controllable from 4.704Mhz, 3.528Mhz, 2.352Mhz, 1.176Mhz and is synchronous to the 24Mhz internal clock. The default frequency is 2.352Mhz.

The two DMIC data inputs are reported as two stereo input pin widgets that incorporate a boost amplifier. The pin widgets are shown connected to the ADCs through the same multiplexors as the analog ports. Although the internal implementation is different between the analog ports and the digital microphones, the functionality is the same. In most cases, the default values for the DMIC clock rate and data sample phase will be appropriate and an audio driver will be able to configure and use the digital microphones exactly like an analog microphone.

92HD73E supports the following digital microphone configurations:

92HD73E

Ten Channel HD Audio Codec

Digital Mics	Data Sample	ADC Conn.	Notes
0	N/A	N/A	No Digital Microphones
1	Single Edge	0, or 1	Available on either DMIC_0 or DMIC_1 Both ADC Channels produce data, may be in phase or out by 1/2 DMIC_CLK period depending upon external configuration and timing
2	Double Edge on either DMIC_0 or 1 OR Single Edge on DMIC_0 and 1	0, or 1	Available on either DMIC_0 or DMIC_1, External logic required to support sampling on a single Digital Mic pin channel on rising edge and second Digital Mic right channel on falling edge of DMIC_CLK for those digital microphones that don't support alternative clock edge capability. If both DMIC_0 and DMIC_1 are used to support 2 digital microphones, 2 separate ADC units will be used, however, this configuration is not recommended since it consumes two stereo ADC resources.
3	Double Edge on one DMIC pin and Single Edge on the second DMIC pin.	0, or 1	Requires both DMIC_0 or DMIC_1, External logic required to support sampling on a single Digital Mic pin channel on rising edge and second Digital Mic right channel on falling edge of DMIC_CLK for those digital microphones that don't support alternative clock edge capability. Two ADC units are required to support this configuration
4	Double Edge	0, or 1	Connected to DMIC_0 and DMIC_1, External logic required to support sampling on a single Digital Mic pin channel on rising edge and second Digital Mic right channel on falling edge of DMIC_CLK for those digital microphones that don't support alternative clock edge capability. Two ADC units are required to support this configuration

Table 11. Valid Digital Mic Configurations

Power State	DMIC Widget Enabled	DMIC_CLK Output	DMIC_0,1	Notes
D0	Yes	Clock Capable	Input Capable	DMIC_CLK Output is Enabled when either DMIC_0 or DMIC_1 Input Widget is Enabled. Otherwise, the DMIC_CLK remains Low
D1-D3	Yes	Clock Disabled	Input Disabled	DMIC_CLK is HIGH-Z with Weak Pull-down
D0-D3	No	Clock Disabled	Input Disabled	DMIC_CLK is HIGH-Z with Weak Pull-down

Table 12. DMIC_CLK and DMIC_0,1 Operation During Power States

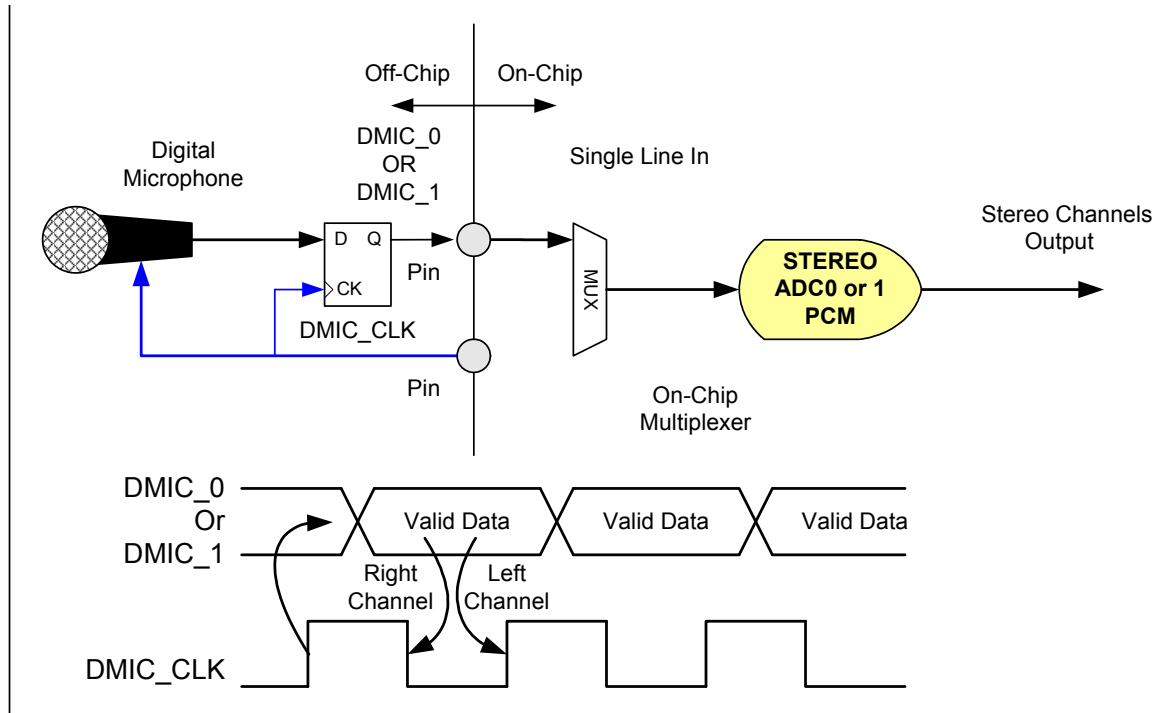

Figure 4: Mono Digital Microphone (data is ported to both left and right channels)

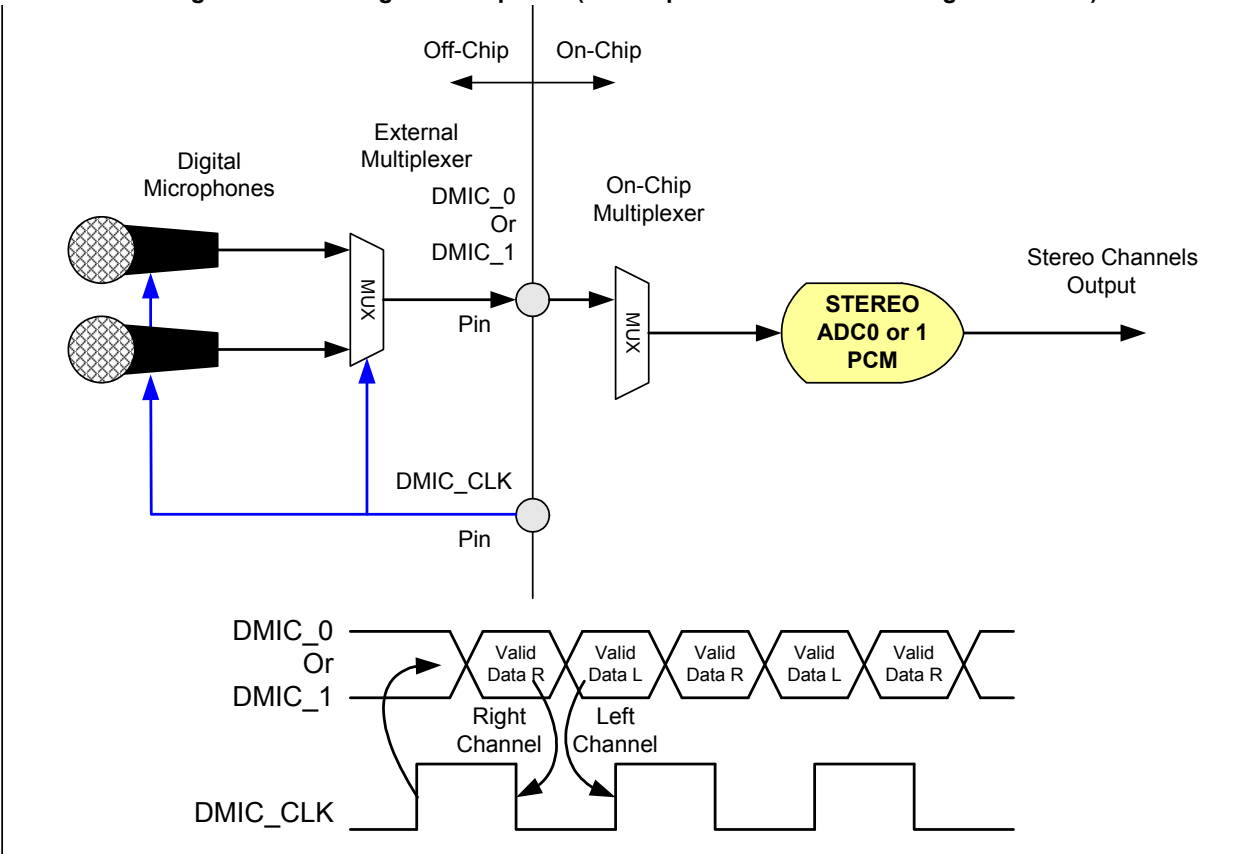

Figure 5: Stereo Digital Microphone Configuration

Note: Some Digital Microphone Implementations support data on either edge, therefore, the external mux may not be required.

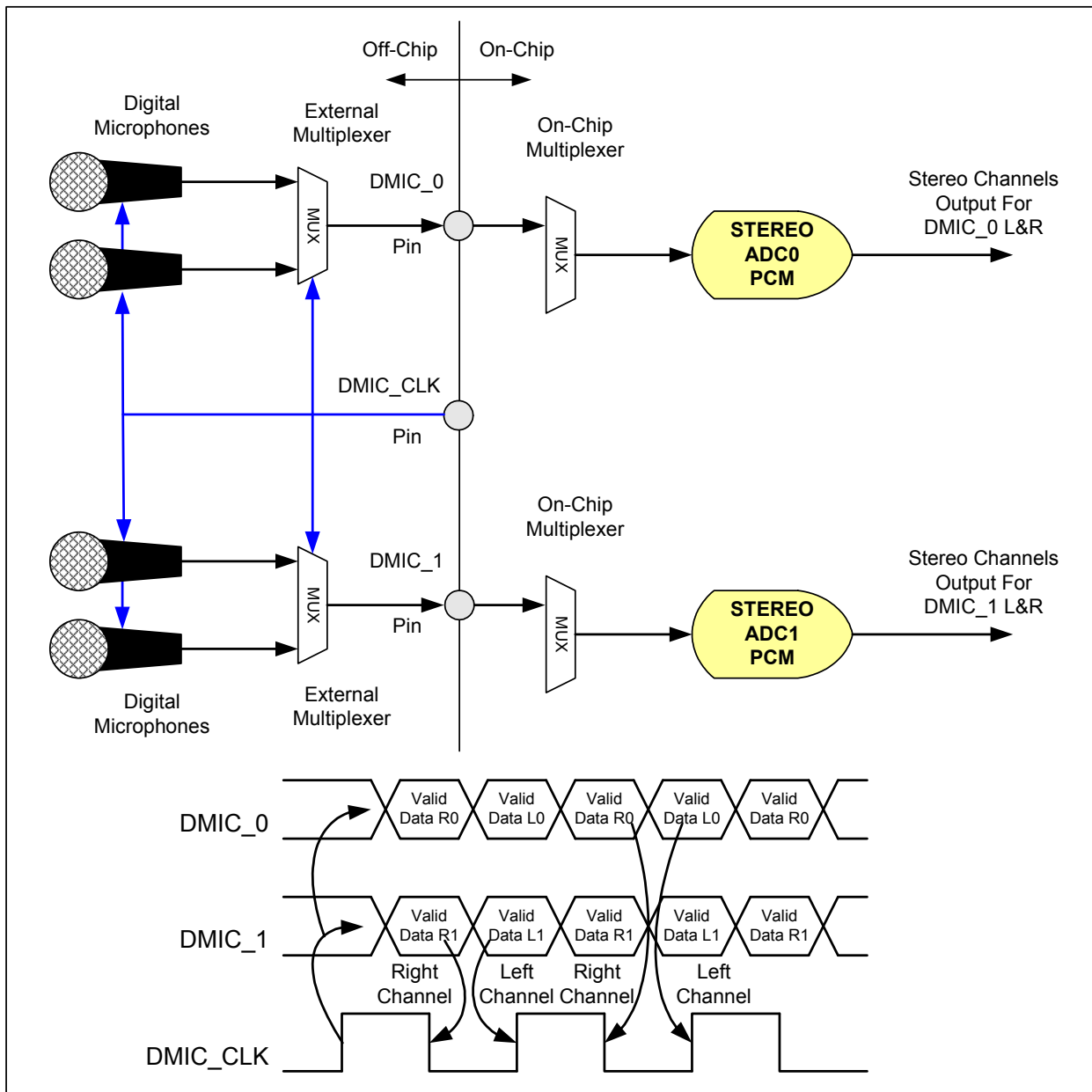

Figure 6: Quad Digital Microphone Configuration

Note: Some Digital Microphone Implementations support data on either edge, therefore, the external mux may not be required.

1.3.14. PC-Beep

92HD73E supports both analog and digital PC_Beep functions.

1.3.14.1. Analog PC-Beep

92HD73E does not support automatic routing of the PC_Beep pin to all outputs when the link is in reset. Analog PC-Beep may be supported during Link Reset if the mixer is manually configured for pass-thru. Otherwise, Reset# must be high and Bit_Clk active.

The default values for the vendor specific verb (7EE/FEE in AFG) associated with Analog PC-Beep are:

- Enable = 0h (Analog PC-Beep disabled - mute)
- volume = 3h (0dB)

Analog PC-Beep is supported in D3, but may be attenuated or distorted depending on the load-impedance on the port. Line outputs can drive 10K ohm loads in D3 at 1Vrms, but will be current limited when driving lower impedance loads. Enabling or disabling analog PC-Beep may cause a click or pop sound.

1.3.14.2. Digital PC-Beep

This block uses an 8-bit divider value to generate the PC beep from the 48kHz Azalia sync pulse. The digital PC_Beep block generates the beep tone on all Pin Complexes that are currently configured as outputs. The HD Audio spec states that the beep tone frequency = (48kHz HD Audio SYNC rate) / (4*Divider), producing tones from 47 Hz to 12 kHz (logarithmic scale). Other audio sources are disabled when digital PC_Beep is active.

It should be noted that digital PC Beep is disabled if the divider = 00h.

1.3.15. Headphone Drivers

This product implements a +3dBV output option on headphone capable ports. (HP output and line output levels are defined as 1Vrms at this time with an option to enable +3dBV FSOV using a vendor specific verb.) The Microsoft Windows Logo Program allows up to the equivalent of 100ohms in series. However, an output level of +3dBV at the pin is required to support 300mV at the jack with a 32ohm load and 1V with a 320 ohm load. Microsoft allows device and system manufactures to limit output voltages to address EU safety requirements. (WLP 3.09 - please refer to the latest Windows Logo Program requirements from Microsoft.) 92HD73E, however, requires external components (series resistors) to limit the output voltage to 150mV with a 32 ohm load or secure software limiting by restricting DAC and mixer gain ranges.

Although 3 Headphone amplifiers are present, only two may be used simultaneously.

Performance will degrade when driving more than one set of headphones. Only one set of headphones (32 ohm nominal) may be connected to a headphone capable port.

1.3.16. GPIO

1.3.16.1. GPIO Pin mapping and shared functions.

GPIO #	Supply	SPDIF In	SPDIF Out	GPI/O	GPI	GPO	VrefOut	DMIC	VOL	Pull Up	Pull Down
0	DVDD	YES		YES						50K (GPIO)	50K ¹ (SPDIF/EAPD)
1	DVDD			YES				CLK	YES	50K (GPIO/VOL)	50K (DMIC)
2	DVDD			YES				IN	YES	50K (GPIO/VOL)	50K (DMIC)
3	AVDD		YES	YES						50K (GPIO)	50K ¹ (SPDIF)
4	AVDD			YES			YES				
5	AVDD			YES				IN		50K ¹	50K (DMIC)
6	AVDD			YES			YES				
7	AVDD			YES			YES				

Table 13. GPIO Pin mapping

1.Default condition.

1.3.16.2. Volume/Digital Microphone/GPIO Selection

There are 3 functions available on pins 2 and 4. To determine which function is actually enabled on the 2 pins, the order of precedence is followed:

1. If the GPIOs are enabled, they override both Volume Control and Digital Mics
2. If the GPIOs are not enabled through the AFG, then at reset, the Volume control is enabled with the weak pull-up.
3. If BIOS or other software application enables either Digital Microphones inputs through the Configuration Default Register, the Volume is disconnected and the pull-ups are disconnected with the weak pull-downs enabled.

1.3.16.3. VRefOut/GPIO Selection

Two functions are available on pins 29, 31, and 37. To determine which function is actually enabled, the order of precedence is followed:

1. If the GPIOx function is enabled, it overrides VRefOut-X
2. If the GPIO function is not enabled through the AFG, then the VrefOut function is enabled and in its default state.
3. If using a VrefOut pin as GPIO, make sure to incorporate a 10K ohm external pull-up to AVDD to prevent the pin from floating in GPI mode and to allow proper operation in open-drain GPO mode.

1.3.17. External Volume Control (on 48QFP package)

92HD73E incorporates a 2-pin volume control interface. Volume up, down, and mute functions are easily implemented using 2 push-button switches. The CODEC provides internal pull-up resistors simplifying external CODEC circuitry. Also, repeat and direct modes of operation add flexibility to the

interface. The typical usage model is for front panel master volume buttons on an entertainment PC, or case mounted hardware volume control for mobile platforms.

1.3.17.1. Theory of Operation

The codec monitors the volume up/down inputs for a change of state from high to low, and waits for the inputs to settle. If the inputs have not settled by the end of the de-bounce period, then the value at the end of the period is used. A 0 (low voltage) on the Down pin will decrement the volume register, while a 0 on the Up pin will increment the volume register. If both inputs are 0 at the same time, then the volume register will be set to its lowest value (mute). Pressing Up, Down, or both buttons at the same time when the volume control interface is in mute mode, will cause the part to un-mute.

The de-bounce / repeat rate is selectable from 2.5Hz to 20Hz in 2.5Hz increments using the Volume Knob VCSR0 verb (FE0) Rate bits (bits 2:0). This value is used for both de-bounce and repeat rates. The de-bounce period is the time that the CODEC waits for the inputs to settle, and the repeat rate is the rate at which the CODEC will increment/decrement the volume if a volume button is pushed and held. When a falling edge is detected on either one of the volume control pins, the codec will wait for (1/Rate) seconds for the input to settle. If the Continuous bit is set in the Volume Knob VCSR0 verb (bit 3), then the codec will wait for the de-bounce period to expire then repeatedly increment or decrement the volume register at the rate specified in the Rate bits until the button is released.

1.3.17.2. Modes of Operation

- DIRECT MODE

In Direct mode, the Volume Knob widget directly controls the volume of all of the DACs in the part. The volume in the Volume Knob widget acts as the master volume and limits the maximum volume for each of the DAC amplifiers. The amp gain for each of the DACs can also be adjusted using the DAC amplifiers. However, the actual gain for an individual DAC will be the sum of the Volume Knob volume and the DAC amplifier volume. For example, if the DAC amplifier gain is set to 0x7F (0dB) and the Volume Knob volume is set to 0x3F (-48dB) the resulting gain would be -48dB. If the combination of gains is less than -95.25dB (the equivalent to a value of 0x0 for the DAC or Volume Knob volume settings) then the actual gain will be -95.25dB. For example, if the Volume Knob is set to 0x3F (-48dB) and the DAC amplifier volume is set to 0x1F (-72dB) then the DAC volume will be set to -95.25dB.

Direct mode is enabled by setting bit 7 in the Volume Knob Cntrl verb (F0F). The volume is reflected in the Volume Knob Cntrl bits 6:0 and the step size is 0.75dB. In direct mode, software can read or write the volume in the Volume Knob widget.

- INDIRECT MODE

In indirect mode, the Volume Knob widget does not directly control the DAC amplifier gains. An event on the volume Up/Down pins will increment/decrement the value in the Volume Knob Cntrl verb (F0F) volume bits (bits 6:0) just as in Direct mode. However, instead of adjusting the DAC amplifier gain, an unsolicited response is generated (if enabled) and the control software must read the volume in the Volume Knob widget and take appropriate action. Indirect mode is particularly useful when it is undesirable to control all of the DAC amplifier volumes at the same time, or when implementing ADC volume control.

In indirect mode, there are only 128 volume levels in the Volume Knob Cntrl volume bits, the value will not go beyond the lower and upper limits (0x0 or 0x7F), and an unsolicited response will be gen-

erated if an input event tries to go beyond these limits. Therefore, it is the responsibility of the controlling software to monitor the volume in the Volume Knob Widget and take appropriate action.

Indirect mode is enabled by clearing bit 7 in the Volume Knob Cntrl verb (F0F). The volume is reflected in the Volume Knob Cntrl bits 6:0 and the step size is 0.75dB. In direct mode, software can read or write the volume in the Volume Knob widget.

1.3.17.3. *Hardware Implementation*

The Volume Knob interface is comprised of two input pins, CODEC pins 2 and 4. Both pins have internal pull-up resistors, so only two push button switches are required for most implementations. Typically, a series resistor and shunt capacitor are used to help reduce noise and prevent damage from ESD and other potential faults. An example circuit is shown below in below.

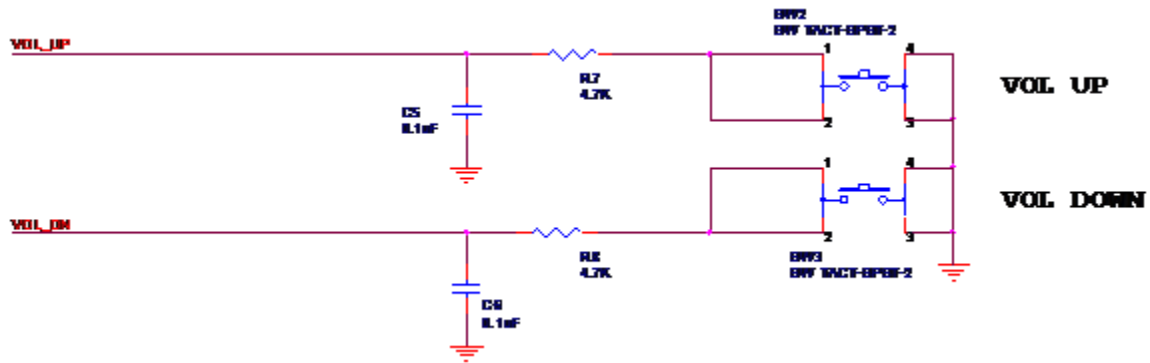

Figure 7: External Volume Control Circuit

2. CHARACTERISTICS

2.1. Electrical Specifications

2.1.1. Absolute Maximum Ratings

Stresses above the ratings listed below can cause permanent damage to the 92HD73E. These ratings, which are standard values for IDT commercially rated parts, are stress ratings only. Functional operation of the device at these or any other conditions above those indicated in the operational sections of the specifications is not implied. Exposure to absolute maximum rating conditions for extended periods can affect product reliability. Electrical parameters are guaranteed only over the recommended operating temperature range.

Item	Pin	Maximum Rating
Analog maximum supply voltage	AVdd	6 Volts
Digital maximum supply voltage	DVdd	5.5 Volts
VREFOUT output current		5 mA
Voltage on any pin relative to ground		Vss - 0.3 V to Vdd + 0.3 V
Operating temperature		0 °C to +70 °C -40 °C to +85°C (INDUSTRIAL TEMP for 92HD73E1T only)
Storage temperature		-55 °C to +125 °C
Soldering temperature		Soldering temperature information for all available in the package section of this datasheet.

Table 14. Electrical Specification: Maximum Ratings

2.1.2. Recommended Operating Conditions

Parameter		Min.	Typ.	Max.	Units
Power Supply Voltage	Digital - 3.3 V	3.135	3.3	3.465	V
	Analog - 5 V	4.75	5	5.25	V
Ambient Operating Temperature		0		+70	°C
Case Temperature	T _{case} (48-QFP)			+90	°C
	T _{case} (40-QFN)			+95	°C
	T _{case} Industrial			+110	°C

Table 15. Recommended Operating Conditions

ESD: The 92HD73E is an ESD (electrostatic discharge) sensitive device. The human body and test equipment can accumulate and discharge electrostatic charges up to 4000 Volts without detection. Even though the 92HD73E implements internal ESD protection circuitry, proper ESD precautions should be followed to avoid damaging the functionality or performance.

92HD73E

Ten Channel HD Audio Codec

2.2. 92HD73E Analog Performance Characteristics

(Tambient = 25 °C, AVdd = Supply ± 5%, DVdd = 3.3V ± 5%, AVss=DVss=0V; 20Hz to 20KHz swept sinusoidal input; Sample Frequency = 48 kHz; 0 dB = 1 VRMS, 10KΩ//50pF load, Testbench Characterization BW: 20 Hz – 20 kHz, 0 dB settings on all gain stages)

Parameter	Conditions	AVdd	Min	Typ	Max	Unit
Digital to Analog Converters						
Resolution		All		24		Bits
Dynamic Range ¹ : PCM to All Analog Outputs	-60dB FS signal level	5V	90	94		dB
SNR ² - DAC to All Line-Out Ports	Analog Mixer Disabled, PCM data	5V	90	97		dB
THD+N ³ - DAC to All Line-Out Ports	Analog Mixer Disabled, 0dB FS Signal, PCM data	5V	80	83		dBr
THD+N ³ - DAC to All Line-Out Ports	Analog Mixer Disabled, -1dB FS Signal, PCM data	5V	80	83		dBr
SNR ² - DAC to All Headphone Ports	Analog Mixer Disabled, 10KΩ load, PCM data	5V	90	97		dB
THD+N ³ - DAC to All Headphone Ports	Analog Mixer Disabled, 0dB FS Signal, 10KΩ load, PCM data	5V	80	83		dBr
THD+N ³ - DAC to All Headphone Ports	Analog Mixer Disabled, -1dB FS Signal, 10KΩ load, PCM data	5V	80	83		dBr
SNR ² - DAC to All Headphone Ports	Analog Mixer Disabled, 32Ω load, PCM data	5V	90	97		dB
THD+N ³ - DAC to All Headphone Ports	Analog Mixer Disabled, 0dB FS Signal, 32Ω load, PCM data	5V	65	70		dBr
THD+N ³ - DAC to All Headphone Ports	Analog Mixer Disabled, -1dB FS Signal, 32Ω load, PCM data	5V	65	70		dBr
Any Analog Input (ADC) to DAC Crosstalk	10KHz Signal Frequency. 0dBV signal applied to ADC, DACs idle, ports enabled as output.	All	-	-80	-	dB
Any Analog Input (ADC) to DAC Crosstalk	1KHz Signal Frequency see above	All	-	-85	-	dB
DAC L/R crosstalk	DAC to LO or HP 20-15KHz into 10KΩ load	All	65	70		dB
DAC L/R crosstalk	DAC to HP 20-15KHz into 32Ω load	All	65	70		dB
Gain Error	Analog Mixer Disabled	All			0.5	dB
Interchannel Gain Mismatch	Analog Mixer Disabled	All			0.5	dB
D/A Digital Filter Pass Band ⁴		All	20	-	21,000	Hz
D/A Digital Filter Transition Band		All	21,000	-	31,000	Hz
D/A Digital Filter Stop Band		All	31,000	-	-	Hz
D/A Digital Filter Stop Band Rejection ⁵		All	-100	-	-	dB
D/A Out-of-Band Rejection ⁶		All	-55	-	-	dB
Group Delay (48KHz sample rate)		All	-	-	1	ms

Table 16. 92HD73E Analog Performance Characteristics

92HD73E

Ten Channel HD Audio Codec

Parameter	Conditions	AVdd	Min	Typ	Max	Unit
Attenuation, Gain Step Size DIGITAL		All	-	0.75	-	dB
DAC Offset Voltage		All	-	10	20	mV
Deviation from Linear Phase		All	-	1	10	deg.
Analog Outputs						
Full Scale All Line-Outs	DAC PCM Data	5V	1.00	1.07	-	Vrms
Full Scale All Line-Outs	DAC PCM Data	5V	2.83	3.03	-	Vp-p
All Headphone Capable Outputs	32Ω load	5V	40	60	-	mW (peak)
Amplifier output impedance	Line Outputs Headphone Outputs	All		150 0.1		Ohms
Analog inputs						
Full Scale Input Voltage	0dB Boost @4.75V (input voltage required for 0dB FS output)	5V	1.05	1.10	-	Vrms
All Analog Inputs with boost	10dB Boost	5V	0.31	-	-	Vrms
All Analog Inputs with boost	20dB Boost	5V	0.10	-	-	Vrms
All Analog Inputs with boost	30dB Boost	5V	0.03	-	-	Vrms
Input Impedance		All	-	50	-	KΩ
Input Capacitance		All	-	15	-	pF
Analog Mixer						
SNR ² - All Line-Inputs or DACs to A, B, and D headphone capable outputs	Analog Mixer Enabled, 10KΩ load. DAC playing silence, line inputs driven by ATE. Gain set to 0dB	5V	85	90		dB
THD+N ³ - All Line-Inputs or DACs to A, B, and D headphone capable outputs	Analog Mixer Enabled, 0dB FS Signal, 10KΩ load	5V	70	75		dBr
SNR ² - All Line-Inputs or DACs to A, B, and D headphone capable outputs	Analog Mixer Enabled, 32Ω load. DAC playing silence, Line inputs driven by ATE.	5V	85	90		dB
THD+N ³ - All Line-Inputs or DACs to A, B, and D headphone capable outputs	Analog Mixer Enabled, 0dB FS Signal, 32Ω load	5V	60	70		dBr
SNR ² - DAC to All Line-Out Ports (C, E, F, G, and H)	Analog Mixer Enabled, DACs playing silence, line inputs driven by ATE. Gain set to 0dB	5V	85	90		dB
THD+N ³ - DAC to All Line-Out Ports (C, E, F, G, and H)	Analog Mixer Enabled, 0dB FS Signal, , 10KΩ load	5V	70	75		dBr
Attenuation, Gain Step Size ANALOG		All	-	1.5	-	dB
Gain Drift ⁷		All	-	100	-	ppm/°C
Analog to Digital Converter						
Resolution		All		24		Bits
Dynamic Range ¹ , All Analog Inputs to A/D	High Pass Filer Enabled, -60dB FS, No boost	5V	86	90		dB
SNR ² - All Analog Inputs to A/D	High Pass Filter enabled	5V	86	90		dB

Table 16. 92HD73E Analog Performance Characteristics

92HD73E

Ten Channel HD Audio Codec

Parameter	Conditions	AVdd	Min	Typ	Max	Unit
THD+N ³ All Analog Inputs to A/D	High Pass Filter enabled, -1dB FS signal level	5V	75	85		dBr
THD+N ³ All Analog Inputs to A/D	High Pass Filter enabled, -3dB FS signal level	5V	75	85		dBr
Analog Frequency Response ⁸		All	10	-	30,000	Hz
A/D Digital Filter Pass Band ⁴		All	20	-	21,000	Hz
A/D Digital Filter Transition Band		All	21,000	-	31,000	Hz
A/D Digital Filter Stop Band		All	31,000	-	-	Hz
A/D Digital Filter Stop Band Rejection ⁵		All	-100	-90	-	dB
Group Delay	48 KHz sample rate	All	-	-	1	ms
Any unselected analog Input to ADC Crosstalk	10KHz Signal Frequency	All	-65	-80	-	dB
Any unselected analog Input to ADC Crosstalk	1KHz Signal Frequency	All	-65	-85	-	dB
ADC L/R crosstalk	Any selected input to ADC 20-15Khz	All	-65			dB
DAC to ADC crosstalk	DAC output 0dBFS. All outputs loaded. Input to ADC open. 20-15Khz	All	-55			dB
Spurious Tone Rejection ⁹		All	-	-100	-	dB
Attenuation, Gain Step Size (analog)		All	-	1.5	-	dB
Gain Drift		All	-	100	-	ppm/°C
Interchannel Gain Mismatch ADC		All	-	-	0.5	dB
Power Supply						
Power Supply Rejection Ratio	10kHz	All	-	-60	-	dB
Power Supply Rejection Ratio	1kHz	All	-	-70	-	dB
D0 (7.1 Playback)¹⁰	Single 7.1 stream. No ADC or SPDIF					
Didd	3.3V			68		mA
Aidd	5.0V			50		mA
D0 (Stereo Playback)¹⁰	Single 2 channel stream. No ADC or SPDIF					
Didd	3.3V			38		mA
Aidd	5.0V			37		mA
D0 (idle)¹⁰	All converters enabled but no streams playing					
Didd	3.3V			55		mA
Aidd	5.0V			72		mA
D1¹⁰	Analog mixer active, all converters and ports off					
D1 Didd	3.3V			14		mA
D1 Aidd	5.0V			35		mA
D2¹⁰	All converters, ports and mixer off					

Table 16. 92HD73E Analog Performance Characteristics

92HD73E

Ten Channel HD Audio Codec

Parameter	Conditions	AVdd	Min	Typ	Max	Unit
D2 Didd	3.3V			14		mA
D2 Aidd	5.0V			28		mA
D3¹⁰	Anti-pop enabled					
D3 Didd	3.3V			3		mA
D3 Aidd	5.0V			14		mA
Differential Power¹⁰	Per converter power consumption					
One Stereo ADC Didd	3.3V			11		mA
One Stereo ADC Aidd	5.0V			3		mA
One Stereo DAC Didd	3.3V			10		mA
One Stereo DAC Aidd	5.0V			4		mA
Voltage Reference Outputs						
VREFOut ¹⁰		All	-	0.5 X AVdd	-	V
VREFILT (VAG)		All		0.45 X AVdd		V
Phased Locked Loop						
PLL lock time		All		96	200	usec
PLL (or HD Audio Bit CLK) 24MHz clock jitter		All		150	500	psec
ESD / Latchup						
Latch-up	As described in JESD78A Class II	All		70		degC
ESD - Human Body Model	As described in JESD22-A114-B	All	2K	3K		V
Charged Device Model	As described in JESD22-C101	All	500	1K		V

Table 16. 92HD73E Analog Performance Characteristics

1. Dynamic Range is the ratio of the full scale signal to the noise output with a -60dBFS signal as defined in AES17 as SNR in the presence of signal and outlined in AES6id, measured "A weighted" over 20 Hz to 20 kHz bandwidth
2. Ratio of Full Scale signal to idle channel noise output is measured "A weighted" over a 20 Hz to a 20 kHz bandwidth. (AES17-1991 Idle Channel Noise or EIAJ CP-307 Signal-to-noise Ratio).
3. THD+N ratio as defined in AES17 and outlined in AES6id, non-weighted, over 20 Hz to 20 kHz bandwidth. Results at the jack are dependent on external components and will likely be 1 - 2dB worse.
4. Peak-to-Peak Ripple over Passband meets ± 0.125 dB limits, 48 kHz or 44.1 kHz Sample Frequency. 1dB limit.
5. Stop Band rejection determines filter requirements. Out-of-Band rejection determines audible noise.
6. The integrated Out-of-Band noise generated by the DAC process, during normal PCM audio playback, over a bandwidth 28.8 to 100 kHz, with respect to a 1 Vrms DAC output.
7. Gain drift is the change in analog volume control gain for each step across the supported 0 °C TO 70 °C temperature range referenced to the 25 °C gain value and specified in ppm per °C
8. ± 1 dB limits for Line Output & 0 dB gain, at -20dBV
9. Spurious tone rejection is tested with ADC dither enabled and compared to ADC performance without dither.
10. Can be set to 0.5 or 0.8 AVdd.

3. PORT CONFIGURATIONS

Entertainment PC

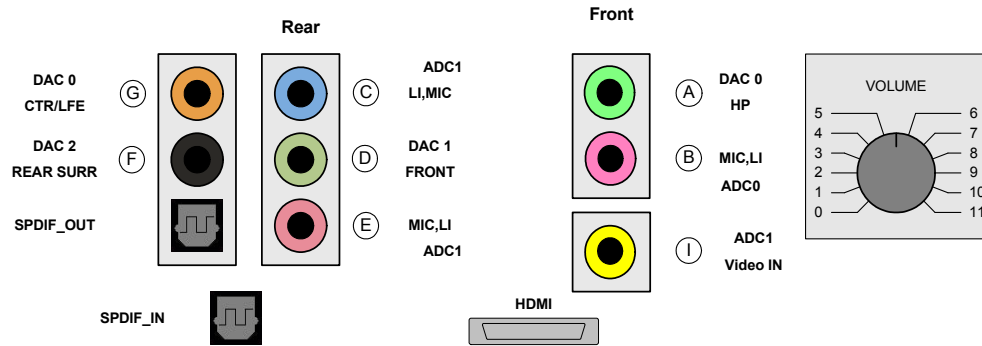

Consumer Desktop

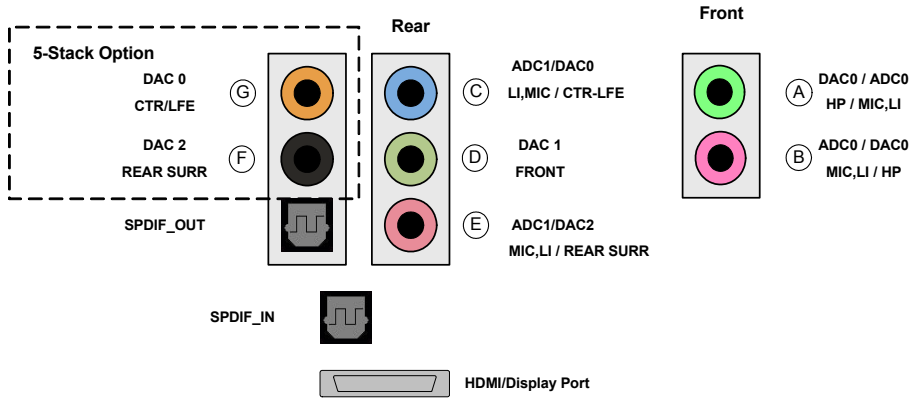

Mobile

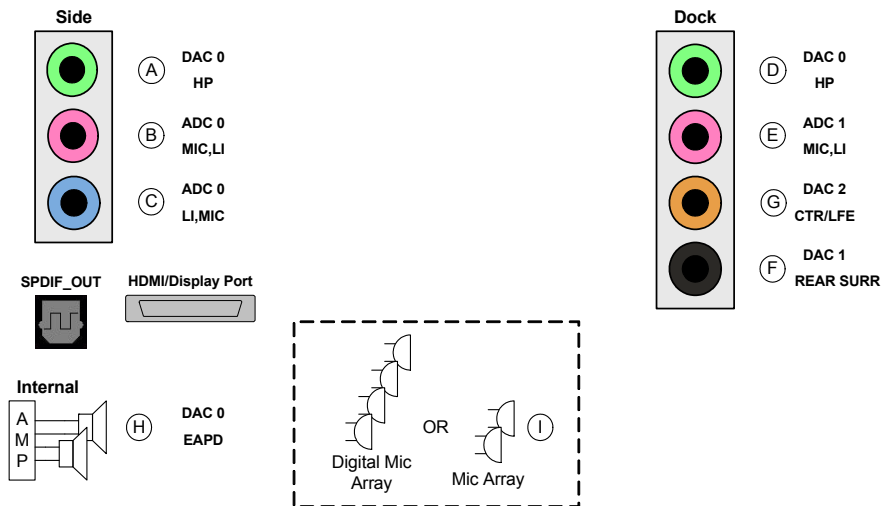

Figure 8. Port Configuration

4. FUNCTIONAL BLOCK DIAGRAMS

4.1. 48QFP

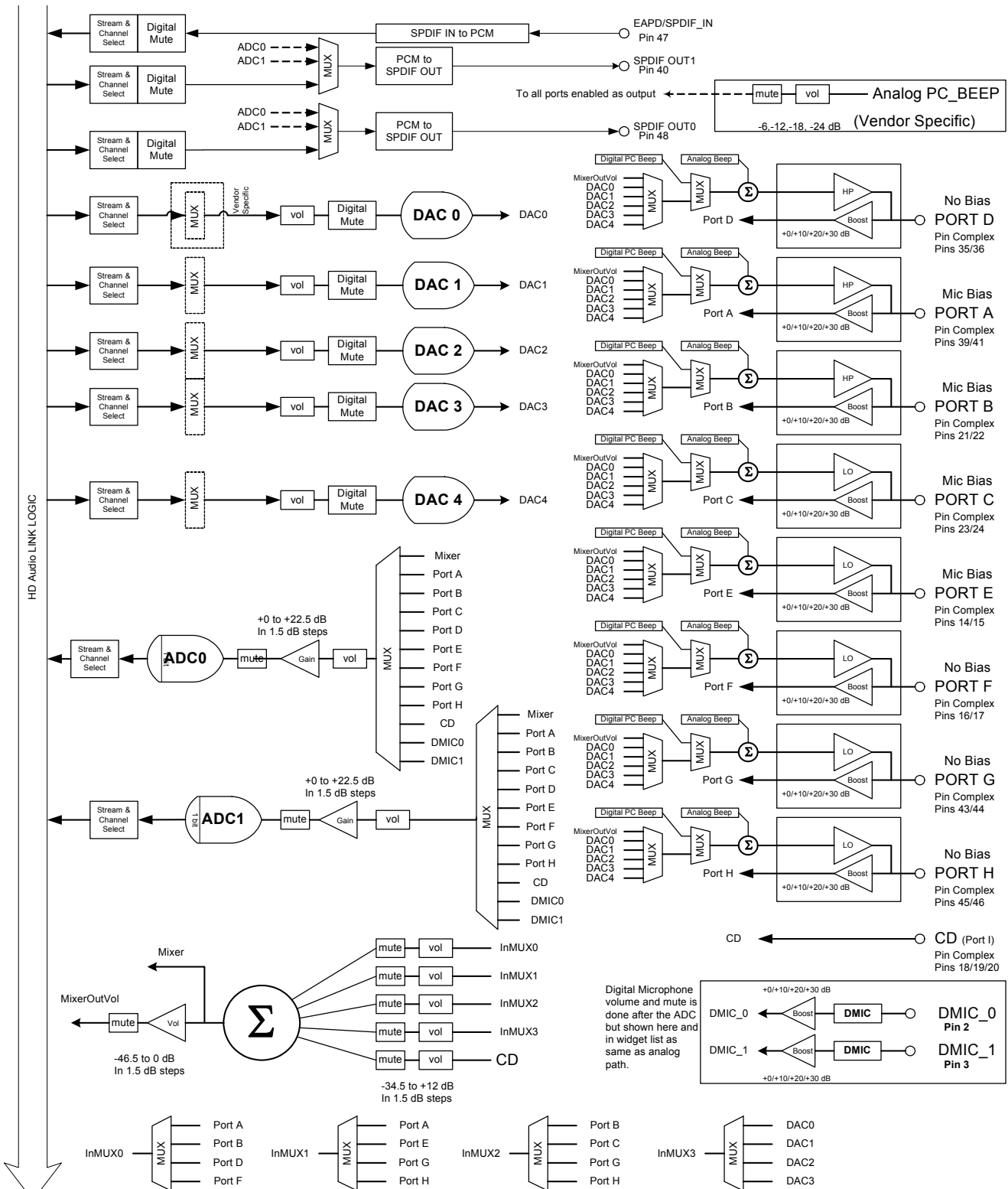

Figure 9. 48QFP Functional Block Diagram

4.2. 40QFN

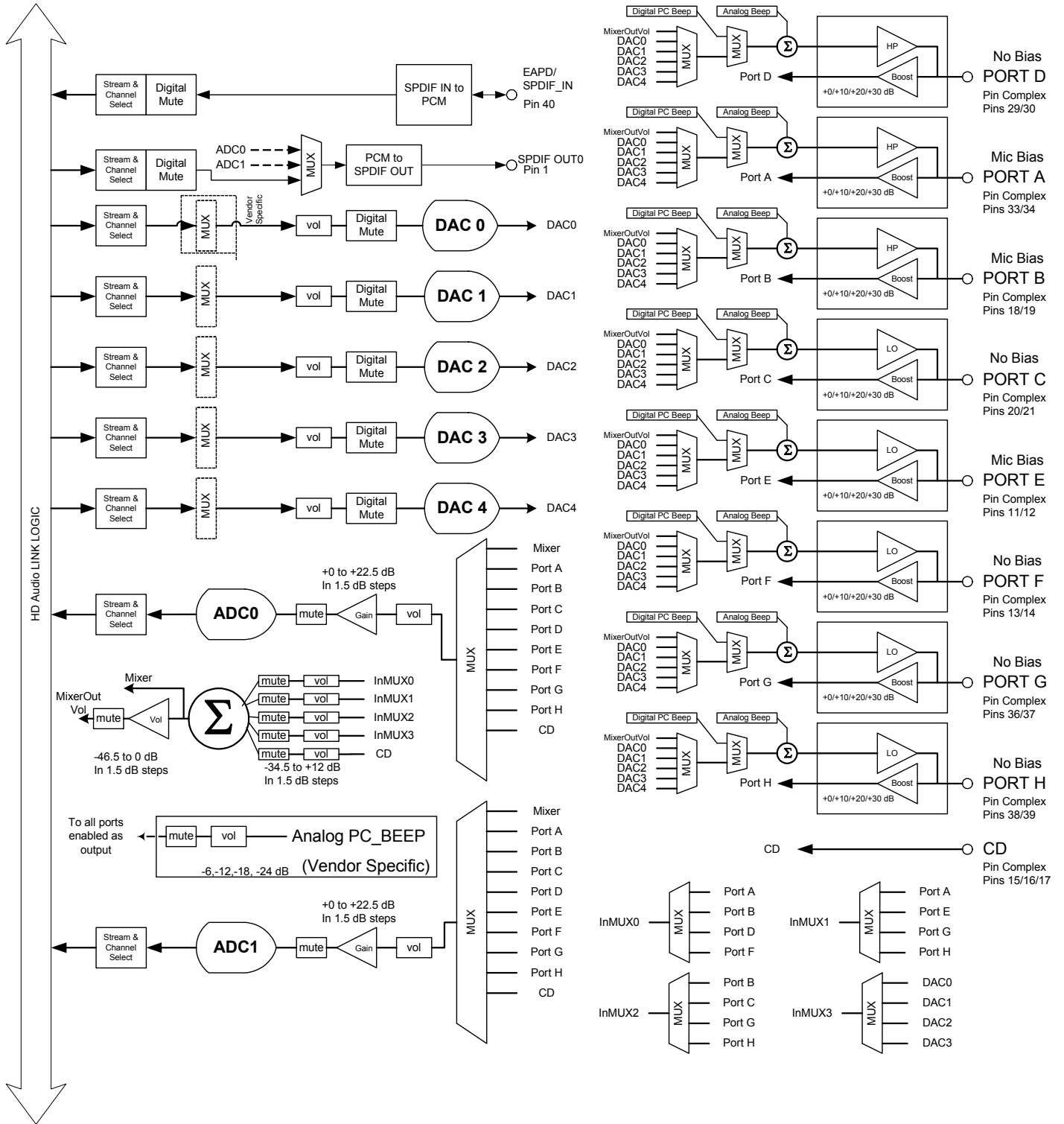

Figure 10. 40QFN Functional Block Diagram

4.3. Widget Information and Supported Command Verbs

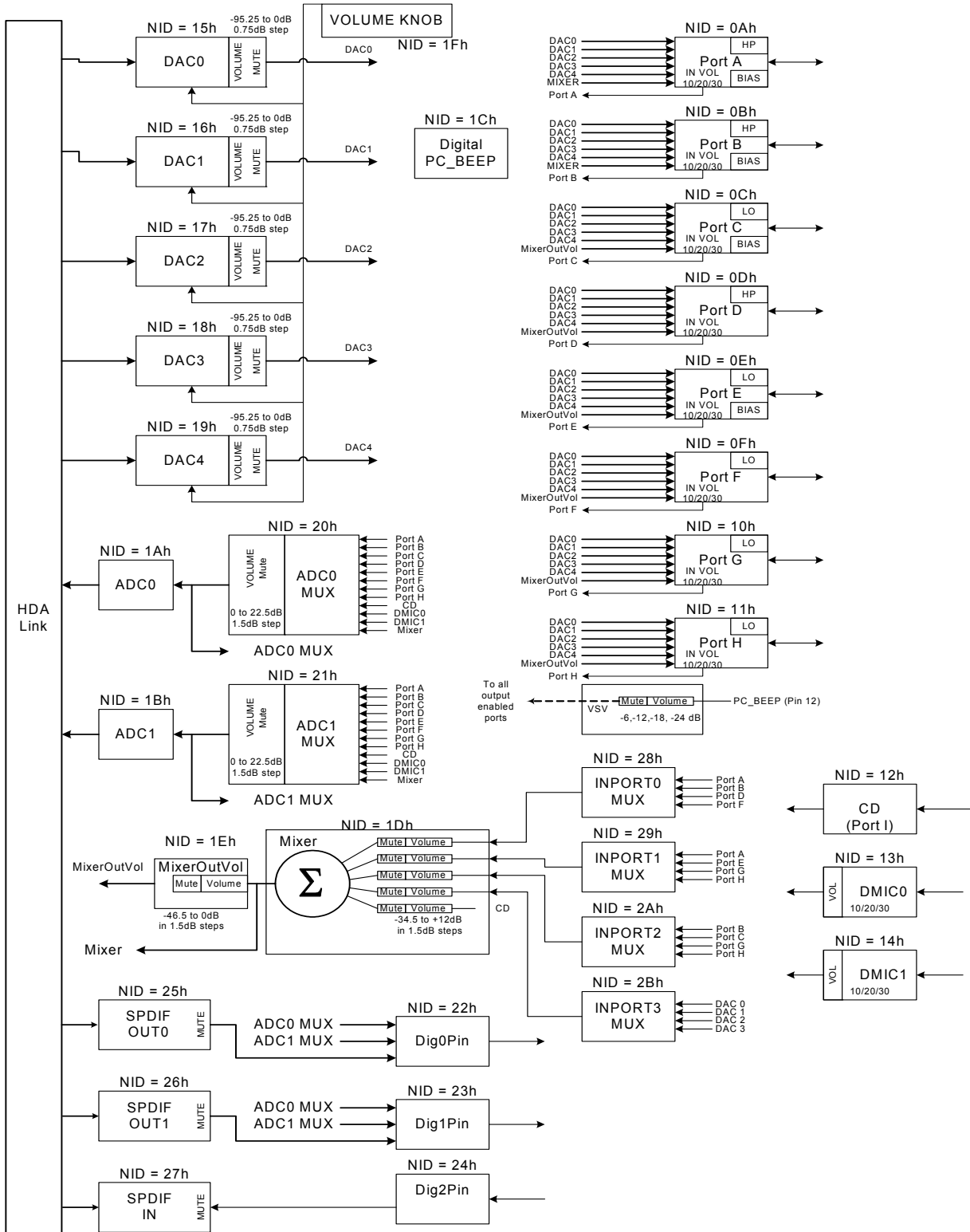

Figure 11. Widget Diagram

4.4. Widget List

ID	Widget Name	Description
00h	Root	Root Node
01h	AFG	Audio Function Group
0Ah	Port A	Port A Pin Widget (Configurable as HP, Line Out, Line In, Mic)
0Bh	Port B	Port B Pin Widget (Configurable as HP, Line Out, Line In, Mic)
0Ch	Port C	Port C Pin Widget (Configurable as Line In, Mic, Line Out)
0Dh	Port D	Port D Pin Widget (Configurable as HP, Line Out, Line In, Mic)
0Eh	Port E	Port E Pin Widget (Configurable as Line In, Mic, Line Out)
0Fh	Port F	Port F Pin Widget (Configurable as Line In, Mic, Line Out)
10h	Port G	Port G Pin Widget (Configurable as Line In, Mic, Line Out)
11h	Port H	Port H Pin Widget (Configurable as Line In, Mic, Line Out)
12h	CD (Port I)	CD Pin Widget (Configurable as Line In)
13h	DigMic0	Digital Microphone 0 Pin Widget
14h	DigMic1	Digital Microphone 1 Pin Widget
15h	DAC0	Stereo Output Converter to DAC
16h	DAC1	Stereo Output Converter to DAC
17h	DAC2	Stereo Output Converter to DAC
18h	DAC3	Stereo Output Converter to DAC (or Vendor Specific Widget)
19h	DAC4	Stereo Output Converter to DAC (or Vendor Specific Widget)
1Ah	ADC0	Stereo Input Converter to ADC
1Bh	ADC1	Stereo Input Converter to ADC
1Ch	PCBeep	Digital PC Beep
1Dh	Mixer	Mixer (Input Ports, DACs, Analog PC_Beep)
1Eh	MixerOutVol	Mixer Out Volume
1Fh	VolumeKnob	External Volume Control
20h	ADC0Mux	ADC0 Mux with volume and mute
21h	ADC1Mux	ADC1 Mux with volume and mute
22h	Dig0Pin	Digital Output Pin (pin48)
23h	Dig1Pin	Secondary Digital Output Pin (pin 40)
24h	Dig2Pin	EAPD and Digital Input Pin (Pin 47)
25h	SPDIFOut0	Stereo Output for SPDIF_Out
26h	SPDIFOut1	Second Stereo Output for SPDIF_Out
27h	SPDIFIn	Stereo converter widget for SPDIF_In
28h	InPort0Mux	Input port pre-select for mixer
29h	InPort1Mux	input port pre-select for mixer
2Ah	InPort2Mux	input port pre-select for mixer

Table 17. High Definition Audio Widget

ID	Widget Name	Description
2Bh	InPort3Mux	input port pre-select for mixer

Table 17. High Definition Audio Widget

4.5. Pin Configuration Default Register Settings

The configuration default registers are 32-bit registers required for each pin widget. These registers are normally used by the CODEC driver to determine the configuration of jacks and devices attached to the CODEC. When the CODEC is powered on, these registers are loaded with the default values provided by IDT for typical system usage, and are loaded in a way that is compatible with the Microsoft Universal Audio Architecture (UAA) driver. The values can be overridden by IDT customers according to their system configuration. Table shows the Pin Widget Configuration Default settings.

The settings reflect the Consumer Desktop use model with:

- Independent Front Headphone and Microphone for real time communication
- 7.1 audio output at the rear
- Rear Microphone and Line Input jacks
- Optical SPDIF input and output jacks at the rear
- HDMI
- Digital Microphones are connected as a 4-mic array (Volume Knob Widget is visible, but inactive)
- Analog CD input is connected to an internal ATAPI connector.

Pin Name	Port	Location	Device	Connection	Color	Misc	Assoc.	Seq
PortAPin	Connect to Jack 00b	Mainboard Front 2h	HP Out 2h	1/8 inch Jack 1h	Green 4h	Jack Detect Override=0	3h	0h
PortBPin	Connect to Jack 00b	Mainboard Front 2h	Mic In Ah	1/8 inch Jack 1h	Pink 9h	Jack Detect Override=0	4h	0h
PortCPin	Connect to Jack 00b	Mainboard Rear 1h	Mic In Ah	1/8 inch Jack 1h	Pink 9h	Jack Detect Override=0	2h	0h
PortDPin	Connect to Jack 00b	Mainboard Rear 1h	Line Out 0h	1/8 inch Jack 1h	Green 4h	Jack Detect Override=0	1h	0h
PortEPin	Connect to Jack 00b	Mainboard Rear 1h	Line In 8h	1/8 inch Jack 1h	Blue 3h	Jack Detect Override=0	2h	Eh
PortFPin	Not Connected 01b	NA 000000b	Other Fh	Unknown 0h	Unknown 0h	Jack Detect Override=0	Fh	0h
MonoOutPin	Not Connected 01b	NA 000000b	Other Fh	Unknown 0h	Unknown 0h	Jack Detect Override=0	Fh	0h
DigOutPin0	Connect to Jack 00b	Mainboard Rear 000001b	SPDIF Out 4h	optical 5h	Gray 2h	Jack Detect Override=0	5h	0h
DigOutPin1	Connect to Jack 10b	Internal 011000b	Digital Other Out 5h	Other Digital 6h	Unknown 0h	Jack Detect Override=0	6h	0h

Table 18. Pin Configuration Default Settings

92HD73E

Ten Channel HD Audio Codec

Pin Name	Port	Location	Device	Connection	Color	Misc	Assoc.	Seq
DigOutPin2	Not Connected 01b	NA 000000b	Other Fh	Unknown 0h	Unknown 0h	Jack Detect Override=0	Fh	0h
DigMic0Pin	Not Connected 01b	NA 000000b	Other Fh	Unknown 0h	Unknown 0h	Jack Detect Override=0	Fh	0h
DigMic1Pin	Not Connected 01b	NA 000000b	Other Fh	Unknown 0h	Unknown 0h	Jack Detect Override=0	Fh	0h
Analog PC_BEEP Pin	Not Connected 01b	NA 000000b	Other Fh	Unknown 0h	Unknown 0h	Jack Detect Override=0	Fh	0h

Table 18. Pin Configuration Default Settings

5. WIDGET INFORMATION

Bits [39:32]	Bits [31:28]	BITS [27:20]	BITS[19:16]	BITS [15:0]
Reserved	CODEC Address	NID	Verb ID (4-bit)	Payload Data (16-bit)

Table 19. Command Format for Verb with 4-bit Identifier

Bits [39:32]	Bits [31:28]	BITS [27:20]	BITS[19:8]	BITS [7:0]
Reserved	CODEC Address	NID	Verb ID (12-bit)	Payload Data (8-bit)

Table 20. Command Format for Verb with 12-bit Identifier

There are two types of responses: Solicited and Unsolicited. Solicited responses are provided as a direct response to an issued command and will be provided in the frame immediately following the command. Unsolicited responses are provided by the CODEC independent of any command. Unsolicited responses are the result of CODEC events such as a jack insertion detection. The formats for Solicited Responses and Unsolicited Responses are shown in the tables below. The “Tag” field in bits [31:28] of the Unsolicited Response identify the event.

Bit [35]	Bit [34]	BITS [33:32]	BITS[31:0]
Valid (Valid = 1)	UnSol = 0	Reserved	Response

Table 21. Solicited Response Format

Bit [35]	Bit [34]	BITS [33:32]	BITS[31:28]	BITS [27:0]
Valid (Valid = 1)	UnSol = 1	Reserved	Tag	Response

Table 22. Unsolicited Response Format

5.1. Root Node (NID = 00)

5.1.1. Root VendorID

	Verb ID	Payload	Response
Get	F00	00	See bitfield table.

5.1.1.1. Root VendorID

Bit	Bitfield Name	RW	Reset	Description
[31.:16]	Vendor	R	111D	Vendor ID.
[15.:8]	DeviceFix	R	xx	Device ID.
[7.:0]	DeviceProg	R	xx	Device ID.

DEVICE ID	CODEC
7676h	92HD73E1X 48QFP 92HD73E1T 48QFP i-temp 92HD73E1X 40QFN

5.1.2. Root RevID

	Verb ID	Payload	Response
Get	F00	02	See bitfield table.

5.1.2.1. Root RevID

Bit	Bitfield Name	RW	Reset	Description
[31.:24]	Rsvd	R	00	Reserved.
[23.:20]	Major	R	1	Compliant HDAudio spec major revision.
[19.:16]	Minor	R	0	Compliant HDAudio spec minor revision
[15.:12]	RevisionFix	R	x	Contact IDT for revision information.
[11.:8]	RevisionProg	R	x	Contact IDT for revision information.
[7.:4]	SteppingFix	R	x	Contact IDT for revision information.
[3.:0]	SteppingProg	R	x	Contact IDT for revision information.

5.1.2.2. *Root NodeInfo*

Bit	Bitfield Name	RW	Reset	Description
[31.:24]	Rsvd2	R	00	Reserved.
[23.:16]	StartNID	R	01	Starting node number (NID) of first function group
[15.:8]	Rsvd1	R	00	Reserved.
[7.:0]	TotalNodes	R	01	Total number of nodes

5.2. AFG Node (NID = 01

)

5.2.1. *AFG Reset*

	Verb ID	Payload	Response
Get			See bitfield table.

5.2.1.1. *AFG Reset*

Bit	Bitfield Name	RW	Reset	Description
[31.:8]	Rsvd1	R	000000	Reserved.
[7.:0]	Execute	W	00	Function Reset.

5.2.2. *AFG NodeInfo*

	Verb ID	Payload	Response
Get	F00	04	See bitfield table.

5.2.2.1. *AFG NodeInfo*

Bit	Bitfield Name	RW	Reset	Description
[31.:24]	Rsvd2	R	00	Reserved.
[23.:16]	StartNID	R	0A	Starting node number for function group subordinate nodes.
[15.:8]	Rsvd1	R	00	Reserved.
[7.:0]	TotalNodes	R	22	Total number of nodes.

5.2.3. AFG FGType

	Verb ID	Payload	Response
Get	F00	05	See bitfield table.

5.2.3.1. AFG FGType

Bit	Bitfield Name	RW	Reset	Description
[31..9]	Rsvd	R	000000	Reserved.
[8]	UnSol	R	1	Unsolicited response supported: 1 = yes 0 = no.
[7.:0]	NodeType	R	1	Function group type: 00h = Reserved; 01h = Audio Function Group; 02h = Vendor Defined Modem Function Group; 03h-7Fh = Reserved; 80h-FFh = Vendor Defined Function Group

5.2.4. AFG AFGCap

	Verb ID	Payload	Response
Get	F00	08	See bitfield table.

5.2.4.1. AFG AFGCap

Bit	Bitfield Name	RW	Reset	Description
[31..17]	Rsvd3	R	00	Reserved.
[16]	BeepGen	R	1	Beep generator present: 1 = yes 0 = no.
[15.:12]	Rsvd2	R	0	Reserved.
[11.:8]	InputDelay	R	D	Typical latency in frames. Number of samples between when the sample is received as an analog signal at the pin and when the digital representation is transmitted on the HD Audio link.
[7.:4]	Rsvd1	R	0	Reserved.
[3.:0]	OutputDelay	R	D	Typical latency in frames. Number of samples between when the signal is received from the HD Audio link and when it appears as an analog signal at the pin.

5.2.5. AFG PCMCap

	Verb ID	Payload	Response
Get	F00	0A	See bitfield table.

5.2.5.1. AFG PCMCap

Bit	Bitfield Name	RW	Reset	Description
[31.:21]	Rsvd2	R	000	Reserved.
[20]	B32	R	0	32 bit audio format support: 1 = yes 0 = no.
[19]	B24	R	1	24 bit audio format support: 1 = yes 0 = no.
[18]	B20	R	1	20 bit audio format support: 1 = yes 0 = no.
[17]	B16	R	1	16 bit audio format support: 1 = yes 0 = no.
[16]	B8	R	0	8 bit audio format support: 1 = yes 0 = no.
[15.:12]	Rsvd1	R	0	Reserved.
[11]	R12	R	0	384kHz rate support: 1 = yes 0 = no.
[10]	R11	R	1	192kHz rate support: 1 = yes 0 = no.
[9]	R10	R	1	176.4kHz rate support: 1 = yes 0 = no.
[8]	R9	R	1	96kHz rate support: 1 = yes 0 = no.
[7]	R8	R	1	88.2kHz rate support: 1 = yes 0 = no.
[6]	R7	R	1	48kHz rate support: 1 = yes 0 = no.
[5]	R6	R	1	44.1kHz rate support: 1 = yes 0 = no.
[4]	R5	R	0	32kHz rate support: 1 = yes 0 = no.
[3]	R4	R	0	22.05kHz rate support: 1 = yes 0 = no.
[2]	R3	R	0	16kHz rate support: 1 = yes 0 = no.
[1]	R2	R	0	11.025kHz rate support: 1 = yes 0 = no.
[0]	R1	R	0	8kHz rate support: 1 = yes 0 = no.

5.2.6. AFG StreamCap

	Verb ID	Payload	Response
Get	F00	0B	See bitfield table.

5.2.6.1. AFG StreamCap

Bit	Bitfield Name	RW	Reset	Description
[31..3]	Rsvd	R	00000000	Reserved.
[2]	AC3	R	0	AC-3 formatted data support: 1 = yes 0 = no.
[1]	Float32	R	0	Float32 formatted data support: 1 = yes 0 = no.
[0]	PCM	R	1	PCM-formatted data support: 1 = yes 0 = no.

5.2.7. AFG InAmpCap

	Verb ID	Payload	Response
Get	F00	0D	See bitfield table.

5.2.7.1. AFG InAmpCap

Bit	Bitfield Name	RW	Reset	Description
[31]	Mute	R	0	Mute support: 1 = yes 0 = no.
[30..23]	Rsvd3	R	00	Reserved.
[22..16]	StepSize	R	27	Size of each step in the gain range: 0 to 127 = .25dB to 32dB in .25dB steps.
[15]	Rsvd2	R	0	Reserved.
[14..8]	NumSteps	R	03	Number of gains steps (number of possible settings - 1).
[7]	Rsvd1	R	0	Reserved.
[6..0]	Offset	R	00	Indicates which step is 0dB

5.2.8. AFG PwrStateCap

	Verb ID	Payload	Response
Get	F00	0F	See bitfield table.

5.2.8.1. AFG PwrStateCap

Bit	Bitfield Name	RW	Reset	Description
[31.:4]	Rsvd	R	0000000	Reserved.
[3]	D3Sup	R	1	D3 power state support: 1 = yes 0 = no.
[2]	D2Sup	R	1	D2 power state support: 1 = yes 0 = no.
[1]	D1Sup	R	1	D1 power state support: 1 = yes 0 = no.
[0]	D0Sup	R	1	D0 power state support: 1 = yes 0 = no.

5.2.9. AFG GPIOCnt

	Verb ID	Payload	Response
Get	F00	11	See bitfield table.

5.2.9.1. AFG GPIOCnt

Bit	Bitfield Name	RW	Reset	Description
[31]	GPIWake	R	1	Wake capability. Assuming the Wake Enable Mask controls are enabled GPIOs configured as inputs can cause a wake (generate a Status Change event on the link) when there is a change in level on the pin.
[30]	GPIUnsol	R	1	GPIO unsolicited response support: 1 = yes 0 = no.
[29.:24]	Rsvd	R	00	Reserved.
[23.:16]	NumGPIs	R	00	Number of GPI pins supported by function group.
[15.:8]	NumGPOs	R	00	Number of GPO pins supported by function group.
[7.:0]	NumGPIOs	R	08	Number of GPIO pins supported by function group.

5.2.10. AFG OutAmpCap

	Verb ID	Payload	Response
Get	F00	12	See bitfield table.

5.2.10.1. AFG OutAmpCap

Bit	Bitfield Name	RW	Reset	Description
[31]	Mute	R	1	Mute support: 1 = yes 0 = no.
[30.:23]	Rsvd3	R	00	Reserved.
[22.:16]	StepSize	R	02	Size of each step in the gain range: 0 to 127 = .25dB to 32dB in .25dB steps.
[15]	Rsvd2	R	0	Reserved.
[14.:8]	NumSteps	R	7F	Number of gains steps (number of possible settings - 1).
[7]	Rsvd1	R	0	Reserved.
[6.:0]	Offset	R	7F	Indicates which step is 0dB

5.2.11. AFG PwrState

	Verb ID	Payload	Response
Get	F05	00	See bitfield table.

5.2.11.1. AFG PwrState

Bit	Bitfield Name	RW	Reset	Description
[31.:6]	Rsvd2	R	0000000	Reserved.
[5.:4]	Act	R	3	Actual power state of this widget.
[3.:2]	Rsvd1	R	0	Reserved.
[1.:0]	Set	RW	3	Current power state setting for this widget.

5.2.12. AFG UnsolResp

	Verb ID	Payload	Response
Get	F08	00	See bitfield table.

5.2.12.1. AFG UnsolResp

Bit	Bitfield Name	RW	Reset	Description
[31..8]	Rsvd2	R	000000	Reserved.
[7]	En	RW	0	Unsolicited response enable: 1 = enabled 0 = disabled.
[6]	Rsvd1	R	0	Reserved.
[5..0]	Tag	RW	00	Software programmable field returned in top six bits (31:26) of every Unsolicited Response generated by this node.

5.2.13. AFG GPIO

	Verb ID	Payload	Response
Get	F15	00	See bitfield table.

5.2.13.1. AFG GPIO

Bit	Bitfield Name	RW	Reset	Description
[31..8]	Rsvd	R	000000	Reserved.
[7]	Data7	RW	0	Data for GPIO7. If this GPIO bit is configured as Sticky (edge-sensitive) input it can be cleared by writing "0". For details of read back value refer to HD Audio spec. section 7.3.3.22
[6]	Data6	RW	0	Data for GPIO6. If this GPIO bit is configured as Sticky (edge-sensitive) input it can be cleared by writing "0". For details of read back value refer to HD Audio spec. section 7.3.3.22
[5]	Data5	RW	0	Data for GPIO5. If this GPIO bit is configured as Sticky (edge-sensitive) input it can be cleared by writing "0". For details of read back value refer to HD Audio spec. section 7.3.3.22

5.2.13.1. AFG GPIO

Bit	Bitfield Name	RW	Reset	Description
[4]	Data4	RW	0	Data for GPIO4. If this GPIO bit is configured as Sticky (edge-sensitive) input it can be cleared by writing "0". For details of read back value refer to HD Audio spec. section 7.3.3.22
[3]	Data3	RW	0	Data for GPIO3. If this GPIO bit is configured as Sticky (edge-sensitive) input it can be cleared by writing "0". For details of read back value refer to HD Audio spec. section 7.3.3.22
[2]	Data2	RW	0	Data for GPIO2. If this GPIO bit is configured as Sticky (edge-sensitive) input it can be cleared by writing "0". For details of read back value refer to HD Audio spec. section 7.3.3.22
[1]	Data1	RW	0	Data for GPIO1. If this GPIO bit is configured as Sticky (edge-sensitive) input it can be cleared by writing "0". For details of read back value refer to HD Audio spec. section 7.3.3.22
[0]	Data0	RW	0	Data for GPIO0. If this GPIO bit is configured as Sticky (edge-sensitive) input it can be cleared by writing "0". For details of read back value refer to HD Audio spec. section 7.3.3.22

5.2.14. AFG GPIOEn

	Verb ID	Payload	Response
Get	F16	00	See bitfield table.

5.2.14.1. AFG GPIOEn

Bit	Bitfield Name	RW	Reset	Description
[31..8]	Rsvd	R	000000	Reserved.
[7]	Mask7	RW	0	Enable for GPIO7: 0 = pin is disabled (Hi-Z state); 1 = pin is enabled; behavior determined by GPIO Direction control

5.2.14.1. AFG GPIOEn

Bit	Bitfield Name	RW	Reset	Description
[6]	Mask6	RW	0	Enable for GPIO6: 0 = pin is disabled (Hi-Z state); 1 = pin is enabled; behavior determined by GPIO Direction control
[5]	Mask5	RW	0	Enable for GPIO5: 0 = pin is disabled (Hi-Z state); 1 = pin is enabled; behavior determined by GPIO Direction control
[4]	Mask4	RW	0	Enable for GPIO4: 0 = pin is disabled (Hi-Z state); 1 = pin is enabled; behavior determined by GPIO Direction control
[3]	Mask3	RW	0	Enable for GPIO3: 0 = pin is disabled (Hi-Z state); 1 = pin is enabled; behavior determined by GPIO Direction control
[2]	Mask2	RW	0	Enable for GPIO2: 0 = pin is disabled (Hi-Z state); 1 = pin is enabled; behavior determined by GPIO Direction control
[1]	Mask1	RW	0	Enable for GPIO1: 0 = pin is disabled (Hi-Z state); 1 = pin is enabled; behavior determined by GPIO Direction control
[0]	Mask0	RW	0	Enable for GPIO0: 0 = pin is disabled (Hi-Z state); 1 = pin is enabled; behavior determined by GPIO Direction control

5.2.15. AFG GPIODir

	Verb ID	Payload	Response
Get	F17	00	See bitfield table.

5.2.15.1. AFG GPIODir

Bit	Bitfield Name	RW	Reset	Description
[31..8]	Rsvd	R	000000	Reserved.
[7]	Control7	RW	0	Direction control for GPIO7: 0 = GPIO is configured as input; 1 = GPIO is configured as output
[6]	Control6	RW	0	Direction control for GPIO6: 0 = GPIO is configured as input; 1 = GPIO is configured as output

5.2.15.1. AFG GPIODir

Bit	Bitfield Name	RW	Reset	Description
[5]	Control5	RW	0	Direction control for GPIO5: 0 = GPIO is configured as input; 1 = GPIO is configured as output
[4]	Control4	RW	0	Direction control for GPIO4: 0 = GPIO is configured as input; 1 = GPIO is configured as output
[3]	Control3	RW	0	Direction control for GPIO3: 0 = GPIO is configured as input; 1 = GPIO is configured as output
[2]	Control2	RW	0	Direction control for GPIO2: 0 = GPIO is configured as input; 1 = GPIO is configured as output
[1]	Control1	RW	0	Direction control for GPIO1: 0 = GPIO is configured as input; 1 = GPIO is configured as output
[0]	Control0	RW	0	Direction control for GPIO0: 0 = GPIO is configured as input; 1 = GPIO is configured as output

5.2.16. AFG GPIOWakeEn

	Verb ID	Payload	Response
Get	F18	00	See bitfield table.

5.2.16.1. AFG GPIOWakeEn

Bit	Bitfield Name	RW	Reset	Description
[31.:8]	Rsvd	R	000000	Reserved.
[7]	W7	RW	0	Wake enable for GPIO7: 0 = wake-up event is disabled; 1 = When HD Audio link is powered down (RST# is asserted) a wake-up event will trigger a Status Change Request event on the link.
[6]	W6	RW	0	Wake enable for GPIO6: 0 = wake-up event is disabled; 1 = When HD Audio link is powered down (RST# is asserted) a wake-up event will trigger a Status Change Request event on the link.

5.2.16.1. AFG GPIOWakeEn

Bit	Bitfield Name	RW	Reset	Description
[5]	W5	RW	0	Wake enable for GPIO5: 0 = wake-up event is disabled; 1 = When HD Audio link is powered down (RST# is asserted) a wake-up event will trigger a Status Change Request event on the link.
[4]	W4	RW	0	Wake enable for GPIO4: 0 = wake-up event is disabled; 1 = When HD Audio link is powered down (RST# is asserted) a wake-up event will trigger a Status Change Request event on the link.
[3]	W3	RW	0	Wake enable for GPIO3: 0 = wake-up event is disabled; 1 = When HD Audio link is powered down (RST# is asserted) a wake-up event will trigger a Status Change Request event on the link.
[2]	W2	RW	0	Wake enable for GPIO2: 0 = wake-up event is disabled; 1 = When HD Audio link is powered down (RST# is asserted) a wake-up event will trigger a Status Change Request event on the link.
[1]	W1	RW	0	Wake enable for GPIO1: 0 = wake-up event is disabled; 1 = When HD Audio link is powered down (RST# is asserted) a wake-up event will trigger a Status Change Request event on the link.
[0]	W0	RW	0	Wake enable for GPIO0: 0 = wake-up event is disabled; 1 = When HD Audio link is powered down (RST# is asserted) a wake-up event will trigger a Status Change Request event on the link.

5.2.17. AFG GPIOUnsol

	Verb ID	Payload	Response
Get	F19	00	See bitfield table.

5.2.17.1. AFG GPIOUnsol

Bit	Bitfield Name	RW	Reset	Description
[31.:8]	Rsvd	R	000000	Reserved.
[7]	EnMask7	RW	0	Unsolicited enable mask for GPIO7. If set and the Unsolicited Response control for this widget has been enabled an unsolicited response will be sent when GPIO2 is configured as input and changes state.
[6]	EnMask6	RW	0	Unsolicited enable mask for GPIO6. If set and the Unsolicited Response control for this widget has been enabled an unsolicited response will be sent when GPIO2 is configured as input and changes state.
[5]	EnMask5	RW	0	Unsolicited enable mask for GPIO5. If set and the Unsolicited Response control for this widget has been enabled an unsolicited response will be sent when GPIO2 is configured as input and changes state.
[4]	EnMask4	RW	0	Unsolicited enable mask for GPIO4. If set and the Unsolicited Response control for this widget has been enabled an unsolicited response will be sent when GPIO2 is configured as input and changes state.
[3]	EnMask3	RW	0	Unsolicited enable mask for GPIO3. If set and the Unsolicited Response control for this widget has been enabled an unsolicited response will be sent when GPIO2 is configured as input and changes state.
[2]	EnMask2	RW	0	Unsolicited enable mask for GPIO2. If set and the Unsolicited Response control for this widget has been enabled an unsolicited response will be sent when GPIO2 is configured as input and changes state.

5.2.17.1. AFG GPIOUnsol

Bit	Bitfield Name	RW	Reset	Description
[1]	EnMask1	RW	0	Unsolicited enable mask for GPIO1. If set and the Unsolicited Response control for this widget has been enabled an unsolicited response will be sent when GPIO1 is configured as input and changes state.
[0]	EnMask0	RW	0	Unsolicited enable mask for GPIO0. If set and the Unsolicited Response control for this widget has been enabled an unsolicited response will be sent when GPIO0 is configured as input and changes state.

5.2.18. AFG GPIOSticky

	Verb ID	Payload	Response
Get	F1A	00	See bitfield table.

5.2.18.1. AFG GPIOSticky

Bit	Bitfield Name	RW	Reset	Description
[31..8]	Rsvd	R	000000	Reserved.
[7]	Mask7	RW	0	GPIO7 input type (when configured as input): 0 = Non-Sticky (level-sensitive); 1 = Sticky (edge-sensitive).
[6]	Mask6	RW	0	GPIO6 input type (when configured as input): 0 = Non-Sticky (level-sensitive); 1 = Sticky (edge-sensitive).
[5]	Mask5	RW	0	GPIO5 input type (when configured as input): 0 = Non-Sticky (level-sensitive); 1 = Sticky (edge-sensitive).
[4]	Mask4	RW	0	GPIO4 input type (when configured as input): 0 = Non-Sticky (level-sensitive); 1 = Sticky (edge-sensitive).
[3]	Mask3	RW	0	GPIO3 input type (when configured as input): 0 = Non-Sticky (level-sensitive); 1 = Sticky (edge-sensitive).

5.2.18.1. AFG GPIOSticky

Bit	Bitfield Name	RW	Reset	Description
[2]	Mask2	RW	0	GPIO2 input type (when configured as input): 0 = Non-Sticky (level-sensitive); 1 = Sticky (edge-sensitive).
[1]	Mask1	RW	0	GPIO1 input type (when configured as input): 0 = Non-Sticky (level-sensitive); 1 = Sticky (edge-sensitive).
[0]	Mask0	RW	0	GPIO0 input type (when configured as input): 0 = Non-Sticky (level-sensitive); 1 = Sticky (edge-sensitive).

5.2.19. AFG SubID

	Verb ID	Payload	Response
Get	F20	00	See bitfield table.

5.2.19.1. AFG SubID

Bit	Bitfield Name	RW	Reset	Description
[31.:24]	Subsys3	RW	00	Subsystem ID (byte 3)
[23.:16]	Subsys2	RW	00	Subsystem ID (byte 2)
[15.:8]	Subsys1	RW	01	Subsystem ID (byte 1)
[7.:0]	Assembly	RW	00	Assembly ID (Not applicable to codec vendors).

5.2.20. AFG GPIOIrty

	Verb ID	Payload	Response
Get	F70	00	See bitfield table.

5.2.20.1. AFG GPIOIrty

Bit	Bitfield Name	RW	Reset	Description
[31..8]	Rsvd	R	000000	Reserved.
[7]	GP7	RW	1	GPIO7 Polarity: If configured as output or non-sticky input: 0 = inverting; 1 = non-inverting. If configured as sticky input: 0 = falling edges will be detected; 1 = rising edges will be detected
[6]	GP6	RW	1	GPIO6 Polarity: If configured as output or non-sticky input: 0 = inverting; 1 = non-inverting. If configured as sticky input: 0 = falling edges will be detected; 1 = rising edges will be detected
[5]	GP5	RW	1	GPIO5 Polarity: If configured as output or non-sticky input: 0 = inverting; 1 = non-inverting. If configured as sticky input: 0 = falling edges will be detected; 1 = rising edges will be detected
[4]	GP4	RW	1	GPIO4 Polarity: If configured as output or non-sticky input: 0 = inverting; 1 = non-inverting. If configured as sticky input: 0 = falling edges will be detected; 1 = rising edges will be detected
[3]	GP3	RW	1	GPIO3 Polarity: If configured as output or non-sticky input: 0 = inverting; 1 = non-inverting. If configured as sticky input: 0 = falling edges will be detected; 1 = rising edges will be detected
[2]	GP2	RW	1	GPIO2 Polarity: If configured as output or non-sticky input: 0 = inverting; 1 = non-inverting. If configured as sticky input: 0 = falling edges will be detected; 1 = rising edges will be detected
[1]	GP1	RW	1	GPIO1 Polarity: If configured as output or non-sticky input: 0 = inverting; 1 = non-inverting. If configured as sticky input: 0 = falling edges will be detected; 1 = rising edges will be detected
[0]	GP0	RW	1	GPIO0 Polarity: If configured as output or non-sticky input: 0 = inverting; 1 = non-inverting. If configured as sticky input: 0 = falling edges will be detected; 1 = rising edges will be detected

5.2.21. AFG GPIODrive

	Verb ID	Payload	Response
Get	F71	00	See bitfield table.

5.2.21.1. AFG GPIODrive

Bit	Bitfield Name	RW	Reset	Description
[31..8]	Rsvd	R	000000	Reserved.
[7]	OD7	RW	0	GPIO7 Drive Mode: 0 = push-pull (drive 0 and 1); 1 = open drain (drive 0 float for 1).
[6]	OD6	RW	0	GPIO6 Drive Mode: 0 = push-pull (drive 0 and 1); 1 = open drain (drive 0 float for 1).
[5]	OD5	RW	0	GPIO5 Drive Mode: 0 = push-pull (drive 0 and 1); 1 = open drain (drive 0 float for 1).
[4]	OD4	RW	0	GPIO4 Drive Mode: 0 = push-pull (drive 0 and 1); 1 = open drain (drive 0 float for 1).
[3]	OD3	RW	0	GPIO3 Drive Mode: 0 = push-pull (drive 0 and 1); 1 = open drain (drive 0 float for 1).
[2]	OD2	RW	0	GPIO2 Drive Mode: 0 = push-pull (drive 0 and 1); 1 = open drain (drive 0 float for 1).
[1]	OD1	RW	0	GPIO1 Drive Mode: 0 = push-pull (drive 0 and 1); 1 = open drain (drive 0 float for 1).
[0]	OD0	RW	0	GPIO0 Drive Mode: 0 = push-pull (drive 0 and 1); 1 = open-drain (drive 0 float for 1).

5.2.22. AFG DMic

	Verb ID	Payload	Response
Get	F78	00	See bitfield table.

5.2.22.1. AFG DMic

Bit	Bitfield Name	RW	Reset	Description
[31..6]	Rsvd	R	0000000	Reserved.
[5]	Mono1	RW	0	DMic1 mono select: 0 = stereo operation, 1 = mono operation (left channel duplicated to the right channel).
[4]	Mono0	RW	0	DMic0 mono select: 0 = stereo operation, 1 = mono operation (left channel duplicated to the right channel).
[3..2]	PhAdj	RW	0	Selects what phase of the DMic clock the data should be latched: 0h = left data rising edge/right data falling edge; 1h = left data center of high/right data center of low; 2h = left data falling edge/right data rising edge; 3h = left data center of low/right data center of high
[1..0]	Rate	RW	2	Selects the DMic clock rate: 0h = 4.704MHz; 1h = 3.528MHz; 2h = 2.352MHz; 3h = 1.176MHz.

5.2.23. AFG AnaBeep

	Verb ID	Payload	Response
Get	FEE	00	See bitfield table.

5.2.23.1. AFG AnaBeep

Bit	Bitfield Name	RW	Reset	Description
[31..3]	Rsvd	R	0000000	Reserved.
[2:1]	Gain	RW	3	Analog PCBeep Gain 0h=-18dB 1h=-12dB 2h=-6dB 3h=0dB
[0]	Enable	RW	0	Analog PCBeep enable 1=Analog PC Beep enabled 0=disabled

5.3. Port A Node (NID = 0A)

5.3.1. PortA WCap

	Verb ID	Payload	Response
Get	F00	09	See bitfield table.

5.3.1.1. PortA WCap

Bit	Bitfield Name	RW	Reset	Description
[31..24]	Rsvd2	R	00	Reserved.
[23..20]	Type	R	4	Widget type: 0h = Out Converter; 1h = In Converter; 2h = Summing (Mixer); 3h = Selector (Mux); 4h = Pin Complex; 5h = Power; 6h = Volume Knob; 7h = Beep Generator; 8h-Eh = Reserved; Fh = Vendor Defined
[19..16]	Delay	R	0	Number of sample delays through widget.
[15..12]	Rsvd1	R	0	Reserved.
[11]	SwapCap	R	0	Left/right swap support: 1 = yes 0 = no.
[10]	PwrCntrl	R	0	Power state support: 1 = yes 0 = no.
[9]	Dig	R	0	Digital stream support: 1 = yes (digital) 0 = no (analog).
[8]	ConnList	R	1	Connection list present: 1 = yes 0 = no.
[7]	UnSolCap	R	1	Unsolicited response support: 1 = yes 0 = no.
[6]	ProcWidget	R	0	Processing state support: 1 = yes 0 = no.
[5]	Stripe	R	0	Striping support: 1 = yes 0 = no.
[4]	FormatOvrd	R	0	Stream format override: 1 = yes 0 = no.
[3]	AmpParOvrd	R	0	Amplifier capabilities override: 1 = yes no.
[2]	OutAmpPrsnt	R	0	Output amp present: 1 = yes 0 = no.

5.3.1.1. *PortA WCap*

Bit	Bitfield Name	RW	Reset	Description
[1]	InAmpPrsnt	R	1	Input amp present: 1 = yes 0 = no.
[0]	Stereo	R	1	Stereo stream support: 1 = yes (stereo) 0 = no (mono).

5.3.2. *PortA PinCap*

	Verb ID	Payload	Response
Get	F00	0C	See bitfield table.

5.3.2.1. *PortA PinCap*

Bit	Bitfield Name	RW	Reset	Description
[31..17]	Rsvd2	R	0000	Reserved.
[16]	EapdCap	R	0	EAPD support: 1 = yes 0 = no.
[15..8]	VrefCntrl	R	00	Vref support: bit 7 = Reserved; bit 6 = Reserved; bit 5 = 100% support (1 = yes 0 = no); bit 4 = 80% support (1 = yes 0 = no); bit 3 = Reserved; bit 2 = GND support (1 = yes 0 = no); bit 1 = 50% support (1 = yes 0 = no); bit 0 = Hi-Z support (1 = yes 0 = no)
[7]	Rsvd1	R	0	Reserved.
[6]	BalancedIO	R	0	Balanced I/O support: 1 = yes 0 = no.
[5]	InCap	R	1	Input support: 1 = yes 0 = no.
[4]	OutCap	R	1	Output support: 1 = yes 0 = no.
[3]	HdphDrvCap	R	1	Headphone amp present: 1 = yes 0 = no.
[2]	PresDtctCap	R	1	Presence detection support: 1 = yes 0 = no.
[1]	TrigRqd	R	0	Trigger required for impedance sense: 1 = yes 0 = no.
[0]	ImpSenseCap	R	0	Impedance sense support: 1 = yes 0 = no.

5.3.3. PortA ConLst

	Verb ID	Payload	Response
Get	F00	0E	See bitfield table.

5.3.3.1. PortA ConLst

Bit	Bitfield Name	RW	Reset	Description
[31..8]	Rsvd	R	000000	Reserved.
[7]	LForm	R	0	Connection list format: 1 = long-form (15-bit) NID entries 0 = short-form (7-bit) NID entries.
[6..0]	ConL	R	03	Number of NID entries in connection list.

5.3.4. PortA ConLstEntry0

	Verb ID	Payload	Response
Get	F02	00	See bitfield table.

5.3.4.1. PortA ConLstEntry0

Bit	Bitfield Name	RW	Reset	Description
[31..24]	ConL3	R	00	Unused list entry.
[23..16]	ConL2	R	1E	InputMixer Summing widget (0x1E)
[15]	ConL1Range	R	1	1 = ConL0..ConL1 defines a range of selectable inputs.
[14..8]	ConL1	R	19	DAC1 Converter widget (0x19)
[7..0]	ConL0	R	15	DAC0 Converter widget (0x15)

5.3.5. PortA ConSelectCtrl

	Verb ID	Payload	Response
Get	F01	00	See bitfield table.

5.3.5.1. PortA ConSelectCtrl

Bit	Bitfield Name	RW	Reset	Description
[31..2]	Rsvd	R	00000000	Reserved.
[1..0]	Index	RW	0	Connection select control index.

5.3.6. PortA PinWCntrl

	Verb ID	Payload	Response
Get	F07	00	See bitfield table.

5.3.6.1. PortA PinWCntrl

Bit	Bitfield Name	RW	Reset	Description
[31..8]	Rsvd2	R	000000	Reserved.
[7]	HPHnEn	RW	0	Headphone amp enable: 1 = enabled 0 = disabled.
[6]	OutEn	RW	0	Output enable: 1 = enabled 0 = disabled.
[4..3]	Rsvd1	R	0	Reserved.
[2..0]	VRefEn	RW	0	Vref selection (See VrefCntrl field of PinCap parameter for supported selections): 000b= HI-Z, 001b= 50% 010b= GND, 011b= Reserved 100b= 80%, 101b= 100% 110b= Reserved, 111b= Reserved

5.3.7. *PortA UnsolResp*

	Verb ID	Payload	Response
Get	F08	00	See bitfield table.

5.3.7.1. *PortA UnsolResp*

Bit	Bitfield Name	RW	Reset	Description
[31..8]	Rsvd2	R	000000	Reserved.
[7]	En	RW	0	Unsolicited response enable: 1 = enabled 0 = disabled.
[6]	Rsvd1	R	0	Reserved.
[5..0]	Tag	RW	00	Software programmable field returned in top six bits (31:26) of every Unsolicited Response generated by this node.

5.3.8. *PortA ChSense*

	Verb ID	Payload	Response
Get	F09	00	See bitfield table.

5.3.8.1. *PortA ChSense*

Bit	Bitfield Name	RW	Reset	Description
[31]	PresDtct	R	0	Presence detection indicator: 1 = presence detected; 0 = presence not detected.
[30.:1]	Impedence	R	3FFFFFFF	Impedance Sense Value (Bits 30:1): Measured impedance of the widget. An all ones value indicates an invalid sense reading
[0]	Execute	RW	1	Impedance Sense Value (Bit 0)/Trigger: Read = Impedance value bit 0 Write 0 = Impedance sense occurs using left channel Write 1 = Impedance sense occurs using right channel

5.3.9. PortA InAmpLeft

	Verb ID	Payload	Response
Get	B20	00	See bitfield table.

5.3.9.1. PortA InAmpLeft

Bit	Bitfield Name	RW	Reset	Description
[31..2]	Rsvd1	R	00000000	Reserved.
[1..0]	Gain	RW	0	Amp gain step number (see InAmpCap parameter pertaining to this widget).

5.3.10. PortA InAmpRight

	Verb ID	Payload	Response
Get	B00	00	See bitfield table.

5.3.10.1. PortA InAmpRight

Bit	Bitfield Name	RW	Reset	Description
[31..2]	Rsvd1	R	00000000	Reserved.
[1..0]	Gain	RW	0	Amp gain step number (see InAmpCap parameter pertaining to this widget).

5.3.11. PortA ConfigDefault

	Verb ID	Payload	Response
Get	F1C	00	See bitfield table.

5.3.11.1. PortA ConfigDefault

Bit	Bitfield Name	RW	Reset	Description
[31.:30]	PortConnectivity	RW	0	Port connectivity: 0h = Port complex is connected to a jack; 1h = No physical connection for port; 2h = Fixed function device is attached; 3h = Both jack and internal device attached (info in all other fields refers to integrated device any presence detection refers to jack)
[29.:24]	Location	RW	02	Location. Bits [5..4]: 0h = External on primary chassis; 1h = Internal; 2h = Separate chassis; 3h = Other. Bits [3..0]: 0h = N/A; 1h = Rear; 2h = Front; 3h = Left; 4h = Right; 5h = Top; 6h = Bottom; 7h-9h = Special; Ah-Fh = Reserved
[23.:20]	Device	RW	2	Default device: 0h = Line out; 1h = Speaker; 2h = HP out; 3h = CD; 4h = SPDIF Out; 5h = Digital other out; 6h = Modem line side; 7h = Modem handset side; 8h = Line in; 9h = Aux; Ah = Mic in; Bh = Telephony; Ch = SPDIF In; Dh = Digital other in; Eh = Reserved; Fh = Other
[19.:16]	Connection Type	RW	1	Connection type: 0h = Unknown; 1h = 1/8" stereo/mono; 2h = 1/4" stereo/mono; 3h = ATAPI internal; 4h = RCA; 5h = Optical; 6h = Other digital; 7h = Other analog; 8h = Multichannel analog (DIN); 9h = XLR/Professional; Ah = RJ-11 (modem); Bh = Combination; Ch-Eh = Reserved; Fh = Other
[15.:12]	Color	RW	4	Color: 0h = Unknown; 1h = Black; 2h = Grey; 3h = Blue; 4h = Green; 5h = Red; 6h = Orange; 7h = Yellow; 8h = Purple; 9h = Pink; Ah-Dh = Reserved; Eh = White; Fh = Other
[11.:8]	Misc	RW	0	Miscellaneous: Bits [3..1] = Reserved; Bit 0 = Jack detect override
[7.:4]	Association	RW	3	Default association.
[3.:0]	Sequence	RW	0	Sequence.

5.4. PortB Node (NID = 0B)

5.4.1. PortB WCap

	Verb ID	Payload	Response
Get	F00	09	See bitfield table.

5.4.1.1. PortB WCap

Bit	Bitfield Name	RW	Reset	Description
[31..24]	Rsvd2	R	00	Reserved.
[23..20]	Type	R	4	Widget type: 0h = Out Converter; 1h = In Converter; 2h = Summing (Mixer); 3h = Selector (Mux); 4h = Pin Complex; 5h = Power; 6h = Volume Knob; 7h = Beep Generator; 8h-Eh = Reserved; Fh = Vendor Defined
[19..16]	Delay	R	0	Number of sample delays through widget.
[15..12]	Rsvd1	R	0	Reserved.
[11]	SwapCap	R	0	Left/right swap support: 1 = yes 0 = no.
[10]	PwrCntrl	R	0	Power state support: 1 = yes 0 = no.
[9]	Dig	R	0	Digital stream support: 1 = yes (digital) 0 = no (analog).
[8]	ConnList	R	1	Connection list present: 1 = yes 0 = no.
[7]	UnSolCap	R	1	Unsolicited response support: 1 = yes 0 = no.
[6]	ProcWidget	R	0	Processing state support: 1 = yes 0 = no.
[5]	Stripe	R	0	Striping support: 1 = yes 0 = no.
[4]	FormatOvrd	R	0	Stream format override: 1 = yes 0 = no.
[3]	AmpParOvrd	R	0	Amplifier capabilities override: 1 = yes no.
[2]	OutAmpPrsnt	R	0	Output amp present: 1 = yes 0 = no.

5.4.1.1. *PortB WCap*

Bit	Bitfield Name	RW	Reset	Description
[1]	InAmpPrsnt	R	1	Input amp present: 1 = yes 0 = no.
[0]	Stereo	R	1	Stereo stream support: 1 = yes (stereo) 0 = no (mono).

5.4.2. *PortB PinCap*

	Verb ID	Payload	Response
Get	F00	0C	See bitfield table.

5.4.2.1. *PortB PinCap*

Bit	Bitfield Name	RW	Reset	Description
[31..17]	Rsvd2	R	0000	Reserved.
[16]	EapdCap	R	0	EAPD support: 1 = yes 0 = no.
[15..8]	VrefCntrl	R	17	Vref support: bit 7 = Reserved; bit 6 = Reserved; bit 5 = 100% support (1 = yes 0 = no); bit 4 = 80% support (1 = yes 0 = no); bit 3 = Reserved; bit 2 = GND support (1 = yes 0 = no); bit 1 = 50% support (1 = yes 0 = no); bit 0 = Hi-Z support (1 = yes 0 = no)
[7]	Rsvd1	R	0	Reserved.
[6]	BalancedIO	R	0	Balanced I/O support: 1 = yes 0 = no.
[5]	InCap	R	1	Input support: 1 = yes 0 = no.
[4]	OutCap	R	1	Output support: 1 = yes 0 = no.
[3]	HdphDrvCap	R	1	Headphone amp present: 1 = yes 0 = no.
[2]	PresDtctCap	R	1	Presence detection support: 1 = yes 0 = no.
[1]	TrigRqd	R	1	Trigger required for impedance sense: 1 = yes 0 = no.
[0]	ImpSenseCap	R	1	Impedance sense support: 1 = yes 0 = no.

5.4.3. PortB ConLstEntry0

	Verb ID	Payload	Response
Get	F00	0E	See bitfield table.

5.4.3.1. PortB ConLst

Bit	Bitfield Name	RW	Reset	Description
[31..8]	Rsvd	R	000000	Reserved.
[7]	LForm	R	0	Connection list format: 1 = long-form (15-bit) NID entries 0 = short-form (7-bit) NID entries.
[6..0]	ConL	R	03	Number of NID entries in connection list.

5.4.4. PortB ConLstEntry0

	Verb ID	Payload	Response
Get	F02	00	See bitfield table.

5.4.4.1. PortB ConLstEntry0

Bit	Bitfield Name	RW	Reset	Description
[31..24]	ConL3	R	00	Unused list entry.
[23..16]	ConL2	R	1E	MixerOutVol Selector widget (0x1E)
[15]	ConL1Range	R	1	1 = ConL0..ConL1 defines a range of selectable inputs.
[14..8]	ConL1	R	19	DAC4 Converter widget (0x19)
[7..0]	ConL0	R	15	DAC0 Converter widget (0x15)

5.4.5. PortB ConSelectCtrl

	Verb ID	Payload	Response
Get	F01	00	See bitfield table.

5.4.5.1. PortB ConSelectCtrl

Bit	Bitfield Name	RW	Reset	Description
[31..2]	Rsvd	R	00000000	Reserved.
[1..0]	Index	RW	0	Connection select control index.

5.4.6. PortB PinWCntrl

	Verb ID	Payload	Response
Get	F07	00	See bitfield table.

5.4.6.1. PortB PinWCntrl

Bit	Bitfield Name	RW	Reset	Description
[31..8]	Rsvd2	R	00000000	Reserved.
[7]	HPhnEn	RW	0	Headphone amp enable: 1 = enabled, 0 = disabled.
[6]	OutEn	RW	0	Output enable: 1 = enabled, 0 = disabled.
[5]	InEn	RW	0	Input enable: 1 = enabled 0 = disabled.
[4..3]	Rsvd1	R	0	Reserved.
[2..0]	VRefEn	RW	0	Vref selection (See VrefCntrl field of PinCap parameter for supported selections): 000b= HI-Z; 001b= 50%; 010b= GND; 011b= Reserved; 100b= 80%; 101b= 100%; 110b= Reserved; 111b= Reserved

5.4.7. PortB UnsolResp

	Verb ID	Payload	Response
Get	F08	00	See bitfield table.

5.4.7.1. PortB UnsolResp

Bit	Bitfield Name	RW	Reset	Description
[31..8]	Rsvd2	R	000000	Reserved.
[7]	En	RW	0	Unsolicited response enable: 1 = enabled 0 = disabled.
[6]	Rsvd1	R	0	Reserved.
[5.:0]	Tag	RW	00	Software programmable field returned in top six bits (31:26) of every Unsolicit- ed Response generated by this node.

5.4.8. PortB ChSense

	Verb ID	Payload	Response
Get	F09	00	See bitfield table.

5.4.8.1. PortB ChSense

Bit	Bitfield Name	RW	Reset	Description
[31]	PresDtct	R	0	Presence detection indicator: 1 = pres- ence detected; 0 = presence not detect- ed.
[30.:1]	Impedence	R	3FFFFFFF	Impedance Sense Value (Bits 30:1): Mea- sured impedance of the widget. An all ones value indicates an invalid sense reading
[0]	Execute	RW	1	Impedance Sense Value (Bit 0)/Trigger: Read = Impedance value bit 0 Write 0 = Impedance sense occurs using left channel Write 1 = Impedance sense occurs using right channel

5.4.9. PortB InAmpLeft

	Verb ID	Payload	Response
Get	B20	00	See bitfield table.

5.4.9.1. PortB InAmpLeft

Bit	Bitfield Name	RW	Reset	Description
[31..2]	Rsvd1	R	000000	Reserved.
[1..0]	Gain	RW	0	Amp gain step number (see InAmpCap parameter pertaining to this widget).

5.4.10. PortD InAmpRight

	Verb ID	Payload	Response
Get	B00	00	See bitfield table.

5.4.10.1. PortD InAmpRight

Bit	Bitfield Name	RW	Reset	Description
[31..2]	Rsvd1	R	000000	Reserved.
[1..0]	Gain	RW	0	Amp gain step number (see InAmpCap parameter pertaining to this widget).

5.4.11. PortB ConfigDefault

	Verb ID	Payload	Response
Get	F1C	00	See bitfield table.

5.4.11.1. PortB ConfigDefault

Bit	Bitfield Name	RW	Reset	Description
[31.:30]	PortConnectivity	RW	0	Port connectivity: 0h = Port complex is connected to a jack; 1h = No physical connection for port; 2h = Fixed function device is attached; 3h = Both jack and internal device attached (info in all other fields refers to integrated device any presence detection refers to jack)
[29.:24]	Location	RW	02	Location. Bits [5..4]: 0h = External on primary chassis; 1h = Internal; 2h = Separate chassis; 3h = Other. Bits [3..0]: 0h = N/A; 1h = Rear; 2h = Front; 3h = Left; 4h = Right; 5h = Top; 6h = Bottom; 7h-9h = Special; Ah-Fh = Reserved
[23.:20]	Device	RW	A	Default device: 0h = Line out; 1h = Speaker; 2h = HP out; 3h = CD; 4h = SPDIF Out; 5h = Digital other out; 6h = Modem line side; 7h = Modem handset side; 8h = Line in; 9h = Aux; Ah = Mic in; Bh = Telephony; Ch = SPDIF In; Dh = Digital other in; Eh = Reserved; Fh = Other
[19.:16]	ConnectionType	RW	1	Connection type: 0h = Unknown; 1h = 1/8" stereo/mono; 2h = 1/4" stereo/mono; 3h = ATAPI internal; 4h = RCA; 5h = Optical; 6h = Other digital; 7h = Other analog; 8h = Multichannel analog (DIN); 9h = XLR/Professional; Ah = RJ-11 (modem); Bh = Combination; Ch-Eh = Reserved; Fh = Other
[15.:12]	Color	RW	9	Color: 0h = Unknown; 1h = Black; 2h = Grey; 3h = Blue; 4h = Green; 5h = Red; 6h = Orange; 7h = Yellow; 8h = Purple; 9h = Pink; Ah-Dh = Reserved; Eh = White; Fh = Other
[11.:8]	Misc	RW	0	Miscellaneous: Bits [3..1] = Reserved; Bit 0 = Jack detect override
[7.:4]	Association	RW	4	Default association.
[3.:0]	Sequence	RW	0	Sequence.

5.5. Port C Node (NID = 0C)

5.5.1. PortC WCap

	Verb ID	Payload	Response
Get	F00	09	See bitfield table.

5.5.1.1. PortC WCap

Bit	Bitfield Name	RW	Reset	Description
[31..24]	Rsvd2	R	00	Reserved.
[23..20]	Type	R	4	Widget type: 0h = Out Converter; 1h = In Converter; 2h = Summing (Mixer); 3h = Selector (Mux); 4h = Pin Complex; 5h = Power; 6h = Volume Knob; 7h = Beep Generator; 8h-Eh = Reserved; Fh = Vendor Defined
[19..16]	Delay	R	0	Number of sample delays through widget.
[15..12]	Rsvd1	R	0	Reserved.
[11]	SwapCap	R	0	Left/right swap support: 1 = yes 0 = no.
[10]	PwrCntrl	R	0	Power state support: 1 = yes 0 = no.
[9]	Dig	R	0	Digital stream support: 1 = yes (digital) 0 = no (analog).
[8]	ConnList	R	1	Connection list present: 1 = yes 0 = no.
[7]	UnSolCap	R	1	Unsolicited response support: 1 = yes 0 = no.
[6]	ProcWidget	R	0	Processing state support: 1 = yes 0 = no.
[5]	Stripe	R	0	Striping support: 1 = yes 0 = no.
[4]	FormatOvrd	R	0	Stream format override: 1 = yes 0 = no.
[3]	AmpParOvrd	R	0	Amplifier capabilities override: 1 = yes no.
[2]	OutAmpPrsnt	R	0	Output amp present: 1 = yes 0 = no.

5.5.1.1. *PortC WCap*

Bit	Bitfield Name	RW	Reset	Description
[1]	InAmpPrsnt	R	1	Input amp present: 1 = yes 0 = no.
[0]	Stereo	R	1	Stereo stream support: 1 = yes (stereo) 0 = no (mono).

5.5.2. *PortC PinCap*

	Verb ID	Payload	Response
Get	F00	0C	See bitfield table.

5.5.2.1. *PortC PinCap*

Bit	Bitfield Name	RW	Reset	Description
[31..17]	Rsvd2	R	0000	Reserved.
[16]	EapdCap	R	0	EAPD support: 1 = yes 0 = no.
[15..8]	VrefCntrl	R	17	Vref support: bit 7 = Reserved; bit 6 = Reserved; bit 5 = 100% support (1 = yes 0 = no); bit 4 = 80% support (1 = yes 0 = no); bit 3 = Reserved; bit 2 = GND support (1 = yes 0 = no); bit 1 = 50% support (1 = yes 0 = no); bit 0 = Hi-Z support (1 = yes 0 = no)
[7]	Rsvd1	R	0	Reserved.
[6]	BalancedIO	R	0	Balanced I/O support: 1 = yes 0 = no.
[5]	InCap	R	1	Input support: 1 = yes 0 = no.
[4]	OutCap	R	1	Output support: 1 = yes 0 = no.
[3]	HdphDrvCap	R	0	Headphone amp present: 1 = yes 0 = no.
[2]	PresDtctCap	R	1	Presence detection support: 1 = yes 0 = no.
[1]	TrigRqd	R	1	Trigger required for impedance sense: 1 = yes 0 = no.
[0]	ImpSenseCap	R	1	Impedance sense support: 1 = yes 0 = no.

5.5.3. *PortC ConLst*

	Verb ID	Payload	Response
Get	F00	0E	See bitfield table.

5.5.3.1. *PortC ConLst*

Bit	Bitfield Name	RW	Reset	Description
[31..8]	Rsvd	R	000000	Reserved.
[7]	LForm	R	0	Connection list format: 1 = long-form (15-bit) NID entries 0 = short-form (7-bit) NID entries.
[6..0]	ConL	R	03	Number of NID entries in connection list.

5.5.4. *PortC ConLstEntry0*

	Verb ID	Payload	Response
Get	F02	00	See bitfield table.

5.5.4.1. *PortC ConLstEntry0*

Bit	Bitfield Name	RW	Reset	Description
[31..24]	ConL3	R	00	Unused list entry.
[23..16]	ConL2	R	17	InputMixer Summing widget (0x1E)
[15]	ConL1Range	R	1	1 = ConL0..ConL1 defines a range of selectable inputs.
[14..8]	ConL1	R	19	DAC4 Converter widget (0x19)
[7..0]	ConL0	R	15	DAC0 Converter widget (0x15)

5.5.5. PortC ConSelectCtrl

	Verb ID	Payload	Response
Get	F01	00	See bitfield table.

5.5.5.1. PortC ConSelectCtrl

Bit	Bitfield Name	RW	Reset	Description
[31..2]	Rsvd	R	00000000	Reserved.
[1..0]	Index	RW	0	Connection select control index.

5.5.6. PortC PinWCntrl

	Verb ID	Payload	Response
Get	F07	00	See bitfield table.

5.5.6.1. PortC PinWCntrl

Bit	Bitfield Name	RW	Reset	Description
[31..6]	Rsvd2	R	00000000	Reserved.
[5]	InEn	RW	0	Input enable: 1 = enabled 0 = disabled.
[4..3]	Rsvd1	R	0	Reserved.
[2..0]	VRefEn	RW	0	Vref selection (See VrefCntrl field of PinCap parameter for supported selections): 000b= HI-Z; 001b= 50%; 010b= GND; 011b= Reserved; 100b= 80%; 101b= 100%; 110b= Reserved; 111b= Reserved

5.5.7. PortC UnsolResp

	Verb ID	Payload	Response
Get	F08	00	See bitfield table.

5.5.7.1. *PortC UnsolResp*

Bit	Bitfield Name	RW	Reset	Description
[31.:8]	Rsvd2	R	000000	Reserved.
[7]	En	RW	0	Unsolicited response enable: 1 = enabled 0 = disabled.
[6]	Rsvd1	R	0	Reserved.
[5.:0]	Tag	RW	00	Software programmable field returned in top six bits (31:26) of every Unsolicited Response generated by this node.

5.5.8. *PortC ChSense*

	Verb ID	Payload	Response
Get	F09	00	See bitfield table.

5.5.8.1. *PortC ChSense*

Bit	Bitfield Name	RW	Reset	Description
[31]	PresDtct	R	0	Presence detection indicator: 1 = presence detected; 0 = presence not detected.
[30.:1]	Impedence	R	3FFFFFFF	Impedance Sense Value (Bits 30:1): Measured impedance of the widget. An all ones value indicates an invalid sense reading
[0]	Execute	RW	1	Impedance Sense Value (Bit 0)/Trigger: Read = Impedance value bit 0 Write 0 = Impedance sense occurs using left channel Write 1 = Impedance sense occurs using right channel

5.5.9. PortC InAmpLeft

	Verb ID	Payload	Response
Get	B20	00	See bitfield table.

5.5.9.1. PortC InAmpLeft

Bit	Bitfield Name	RW	Reset	Description
[31..2]	Rsvd1	R	00000000	Reserved.
[1..0]	Gain	RW	0	Amp gain step number (see InAmpCap parameter pertaining to this widget).

5.5.10. PortC InAmpRight

	Verb ID	Payload	Response
Get	B00	00	See bitfield table.

5.5.10.1. PortC InAmpRight

Bit	Bitfield Name	RW	Reset	Description
[31..2]	Rsvd1	R	00000000	Reserved.
[1..0]	Gain	RW	0	Amp gain step number (see InAmpCap parameter pertaining to this widget).

5.5.11. PortC ConfigDefault

	Verb ID	Payload	Response
Get	F1C	00	See bitfield table.

5.5.11.1. PortC ConfigDefault

Bit	Bitfield Name	RW	Reset	Description
[31..:30]	PortConnectivity	RW	0	Port connectivity: 0h = Port complex is connected to a jack; 1h = No physical connection for port; 2h = Fixed function device is attached; 3h = Both jack and internal device attached (info in all other fields refers to integrated device any presence detection refers to jack)
[29..:24]	Location	RW	1	Location. Bits [5..4]: 0h = External on primary chassis; 1h = Internal; 2h = Separate chassis; 3h = Other. Bits [3..0]: 0h = N/A; 1h = Rear; 2h = Front; 3h = Left; 4h = Right; 5h = Top; 6h = Bottom; 7h-9h = Special; Ah-Fh = Reserved
[23..:20]	Device	RW	8	Default device: 0h = Line out; 1h = Speaker; 2h = HP out; 3h = CD; 4h = SPDIF Out; 5h = Digital other out; 6h = Modem line side; 7h = Modem handset side; 8h = Line in; 9h = Aux; Ah = Mic in; Bh = Telephony; Ch = SPDIF In; Dh = Digital other in; Eh = Reserved; Fh = Other
[19..:16]	ConnectionType	RW	1	Connection type: 0h = Unknown; 1h = 1/8" stereo/mono; 2h = 1/4" stereo/mono; 3h = ATAPI internal; 4h = RCA; 5h = Optical; 6h = Other digital; 7h = Other analog; 8h = Multichannel analog (DIN); 9h = XLR/Professional; Ah = RJ-11 (modem); Bh = Combination; Ch-Eh = Reserved; Fh = Other
[15..:12]	Color	RW	3	Color: 0h = Unknown; 1h = Black; 2h = Grey; 3h = Blue; 4h = Green; 5h = Red; 6h = Orange; 7h = Yellow; 8h = Purple; 9h = Pink; Ah-Dh = Reserved; Eh = White; Fh = Other
[11..:8]	Misc	RW	0	Miscellaneous: Bits [3..1] = Reserved; Bit 0 = Jack detect override
[7..:4]	Association	RW	2	Default association.
[3..:0]	Sequence	RW	1	Sequence.

5.6. Port D Node (NID = 0D)

5.6.1. PortD WCap

	Verb ID	Payload	Response
Get	F00	09	See bitfield table.

5.6.1.1. PortD WCap

Bit	Bitfield Name	RW	Reset	Description
[31..24]	Rsvd2	R	00	Reserved.
[23..20]	Type	R	4	Widget type: 0h = Out Converter; 1h = In Converter; 2h = Summing (Mixer); 3h = Selector (Mux); 4h = Pin Complex; 5h = Power; 6h = Volume Knob; 7h = Beep Generator; 8h-Eh = Reserved; Fh = Vendor Defined
[19..16]	Delay	R	0	Number of sample delays through widget.
[15..12]	Rsvd1	R	0	Reserved.
[11]	SwapCap	R	0	Left/right swap support: 1 = yes 0 = no.
[10]	PwrCntrl	R	0	Power state support: 1 = yes 0 = no.
[9]	Dig	R	0	Digital stream support: 1 = yes (digital) 0 = no (analog).
[8]	ConnList	R	1	Connection list present: 1 = yes 0 = no.
[7]	UnSolCap	R	1	Unsolicited response support: 1 = yes 0 = no.
[6]	ProcWidget	R	0	Processing state support: 1 = yes 0 = no.
[5]	Stripe	R	0	Striping support: 1 = yes 0 = no.
[4]	FormatOvrd	R	0	Stream format override: 1 = yes 0 = no.
[3]	AmpParOvrd	R	1	Amplifier capabilities override: 1 = yes no.
[2]	OutAmpPrsnt	R	1	Output amp present: 1 = yes 0 = no.

5.6.1.1. *PortD WCap*

Bit	Bitfield Name	RW	Reset	Description
[1]	InAmpPrsnt	R	1	Input amp present: 1 = yes 0 = no.
[0]	Stereo	R	1	Stereo stream support: 1 = yes (stereo) 0 = no (mono).

5.6.2. *PortD PinCap*

	Verb ID	Payload	Response
Get	F00	0C	See bitfield table.

5.6.2.1. *PortD PinCap*

Bit	Bitfield Name	RW	Reset	Description
[31..17]	Rsvd2	R	0000	Reserved.
[16]	EapdCap	R	0	EAPD support: 1 = yes 0 = no.
[15..8]	VrefCntrl	R	00	Vref support: bit 7 = Reserved; bit 6 = Reserved; bit 5 = 100% support (1 = yes 0 = no); bit 4 = 80% support (1 = yes 0 = no); bit 3 = Reserved; bit 2 = GND support (1 = yes 0 = no); bit 1 = 50% support (1 = yes 0 = no); bit 0 = Hi-Z support (1 = yes 0 = no)
[7]	Rsvd1	R	0	Reserved.
[6]	BalancedIO	R	0	Balanced I/O support: 1 = yes 0 = no.
[5]	InCap	R	1	Input support: 1 = yes 0 = no.
[4]	OutCap	R	1	Output support: 1 = yes 0 = no.
[3]	HdphDrvCap	R	1	Headphone amp present: 1 = yes 0 = no.
[2]	PresDtctCap	R	1	Presence detection support: 1 = yes 0 = no.
[1]	TrigRqd	R	0	Trigger required for impedance sense: 1 = yes 0 = no.
[0]	ImpSenseCap	R	0	Impedance sense support: 1 = yes 0 = no.

5.6.3. PortD ConLst

	Verb ID	Payload	Response
Get	F00	0E	See bitfield table.

5.6.3.1. PortD ConLst

Bit	Bitfield Name	RW	Reset	Description
[31..8]	Rsvd	R	000000	Reserved.
[7]	LForm	R	0	Connection list format: 1 = long-form (15-bit) NID entries 0 = short-form (7-bit) NID entries.
[6..0]	ConL	R	03	Number of NID entries in connection list.

5.6.4. PortD ConLstEntry0

	Verb ID	Payload	Response
Get	F02	00	See bitfield table.

5.6.4.1. PortD ConLstEntry0

Bit	Bitfield Name	RW	Reset	Description
[31..24]	ConL3	R	00	Unused list entry.
[23..16]	ConL2	R	1E	MixerOutVol Summing widget (0x1E)
[15]	ConL1Range	R	1	1 = ConL0..ConL1 defines a range of selectable inputs.
[15..8]	ConL1	R	19	DAC4 Converter widget (0x19)
[7..0]	ConL0	R	15	DAC0 Converter widget (0x15)

5.6.5. PortD ConSelectCtrl

	Verb ID	Payload	Response
Get	F01	00	See bitfield table.

5.6.5.1. PortD ConSelectCtrl

Bit	Bitfield Name	RW	Reset	Description
[31..2]	Rsvd	R	00000000	Reserved.
[1..0]	Index	RW	0	Connection select control index.

5.6.6. PortD PinWCntrl

	Verb ID	Payload	Response
Get	F07	00	See bitfield table.

5.6.6.1. PortD PinWCntrl

Bit	Bitfield Name	RW	Reset	Description
[31..8]	Rsvd2	R	000000	Reserved.
[7]	HPhnEn	RW	0	Headphone amp enable: 1 = enabled, 0 = disabled.
[6]	OutEn	RW	0	Output enable: 1 = enabled 0 = disabled.
[5]	InEn	RW	0	Input enable: 1 = enabled 0 = disabled.
[4..0]	Rsvd1	R	0	Reserved.

5.6.7. PortD UnsolResp

	Verb ID	Payload	Response
Get	F08	00	See bitfield table.

5.6.7.1. *PortD UnsolResp*

Bit	Bitfield Name	RW	Reset	Description
[31.:8]	Rsvd2	R	000000	Reserved.
[7]	En	RW	0	Unsolicited response enable: 1 = enabled 0 = disabled.
[6]	Rsvd1	R	0	Reserved.
[5.:0]	Tag	RW	00	Software programmable field returned in top six bits (31:26) of every Unsolicited Response generated by this node.

5.6.8. *PortD ChSense*

	Verb ID	Payload	Response
Get	F09	00	See bitfield table.

5.6.8.1. *PortD ChSense*

Bit	Bitfield Name	RW	Reset	Description
[31]	PresDtct	R	0	Presence detection indicator: 1 = presence detected; 0 = presence not detected.
[30.:1]	Impedence	R	3FFFFFFh	Impedance Sense Value (Bits 30:1): Measured impedance of the widget. An all ones value indicates an invalid sense reading
[0]	Execute	RW	1	Impedance Sense Value (Bit 0)/Trigger: Read = Impedance value bit 0 Write 0 = Impedance sense occurs using left channel Write 1 = Impedance sense occurs using right channel

5.6.9. *PortD InAmpLeft*

	Verb ID	Payload	Response
Get	B20	00	See bitfield table.

5.6.9.1. *PortD InAmpLeft*

Bit	Bitfield Name	RW	Reset	Description
[31..2]	Rsvd1	R	000000	Reserved.
[1..0]	Gain	RW	0	Amp gain step number (see InAmpCap parameter pertaining to this widget).

5.6.10. *PortD InAmpRight*

	Verb ID	Payload	Response
Get	B00	00	See bitfield table.

5.6.10.1. *PortD InAmpRight*

Bit	Bitfield Name	RW	Reset	Description
[31..2]	Rsvd1	R	000000	Reserved.
[1..0]	Gain	RW	0	Amp gain step number (see InAmpCap parameter pertaining to this widget).

5.6.11. *PortD ConfigDefault*

	Verb ID	Payload	Response
Get	F1C	00	See bitfield table.

5.6.11.1. PortD ConfigDefault

Bit	Bitfield Name	RW	Reset	Description
[31.:30]	PortConnectivity	RW	0	Port connectivity: 0h = Port complex is connected to a jack; 1h = No physical connection for port; 2h = Fixed function device is attached; 3h = Both jack and internal device attached (info in all other fields refers to integrated device any presence detection refers to jack)
[29.:24]	Location	RW	1	Location. Bits [5..4]: 0h = External on primary chassis; 1h = Internal; 2h = Separate chassis; 3h = Other. Bits [3..0]: 0h = N/A; 1h = Rear; 2h = Front; 3h = Left; 4h = Right; 5h = Top; 6h = Bottom; 7h-9h = Special; Ah-Fh = Reserved
[23.:20]	Device	RW	0	Default device: 0h = Line out; 1h = Speaker; 2h = HP out; 3h = CD; 4h = SPDIF Out; 5h = Digital other out; 6h = Modem line side; 7h = Modem handset side; 8h = Line in; 9h = Aux; Ah = Mic in; Bh = Telephony; Ch = SPDIF In; Dh = Digital other in; Eh = Reserved; Fh = Other
[19.:16]	ConnectionType	RW	1	Connection type: 0h = Unknown; 1h = 1/8" stereo/mono; 2h = 1/4" stereo/mono; 3h = ATAPI internal; 4h = RCA; 5h = Optical; 6h = Other digital; 7h = Other analog; 8h = Multichannel analog (DIN); 9h = XLR/Professional; Ah = RJ-11 (modem); Bh = Combination; Ch-Eh = Reserved; Fh = Other
[15.:12]	Color	RW	4	Color: 0h = Unknown; 1h = Black; 2h = Grey; 3h = Blue; 4h = Green; 5h = Red; 6h = Orange; 7h = Yellow; 8h = Purple; 9h = Pink; Ah-Dh = Reserved; Eh = White; Fh = Other
[11.:8]	Misc	RW	0	Miscellaneous: Bits [3..1] = Reserved; Bit 0 = Jack detect override
[7.:4]	Association	RW	1	Default association.
[3.:0]	Sequence	RW	0	Sequence.

5.7. PortE Node (NID = 0E)

5.7.1. PortE WCap

	Verb ID	Payload	Response
Get	F00	09	See bitfield table.

5.7.1.1. PortE WCap

Bit	Bitfield Name	RW	Reset	Description
[31..24]	Rsvd2	R	00	Reserved.
[23..20]	Type	R	4	Widget type: 0h = Out Converter; 1h = In Converter; 2h = Summing (Mixer); 3h = Selector (Mux); 4h = Pin Complex; 5h = Power; 6h = Volume Knob; 7h = Beep Generator; 8h-Eh = Reserved; Fh = Vendor Defined
[19..16]	Delay	R	0	Number of sample delays through widget.
[15..12]	Rsvd1	R	0	Reserved.
[11]	SwapCap	R	0	Left/right swap support: 1 = yes 0 = no.
[10]	PwrCntrl	R	0	Power state support: 1 = yes 0 = no.
[9]	Dig	R	0	Digital stream support: 1 = yes (digital) 0 = no (analog).
[8]	ConnList	R	1	Connection list present: 1 = yes 0 = no.
[7]	UnSolCap	R	1	Unsolicited response support: 1 = yes 0 = no.
[6]	ProcWidget	R	0	Processing state support: 1 = yes 0 = no.
[5]	Stripe	R	0	Striping support: 1 = yes 0 = no.
[4]	FormatOvrd	R	0	Stream format override: 1 = yes 0 = no.
[3]	AmpParOvrd	R	0	Amplifier capabilities override: 1 = yes no.
[2]	OutAmpPrsnt	R	0	Output amp present: 1 = yes 0 = no.

5.7.1.1. *PortE WCap*

Bit	Bitfield Name	RW	Reset	Description
[1]	InAmpPrsnt	R	1	Input amp present: 1 = yes 0 = no.
[0]	Stereo	R	1	Stereo stream support: 1 = yes (stereo) 0 = no (mono).

5.7.2. *PortE PinCap*

	Verb ID	Payload	Response
Get	F00	0C	See bitfield table.

5.7.2.1. *PortE PinCap*

Bit	Bitfield Name	RW	Reset	Description
[31..17]	Rsvd2	R	0000	Reserved.
[16]	EapdCap	R	0	EAPD support: 1 = yes 0 = no.
[15..8]	VrefCntrl	R	17	Vref support: bit 7 = Reserved; bit 6 = Reserved; bit 5 = 100% support (1 = yes 0 = no); bit 4 = 80% support (1 = yes 0 = no); bit 3 = Reserved; bit 2 = GND support (1 = yes 0 = no); bit 1 = 50% support (1 = yes 0 = no); bit 0 = Hi-Z support (1 = yes 0 = no)
[7]	Rsvd1	R	0	Reserved.
[6]	BalancedIO	R	0	Balanced I/O support: 1 = yes 0 = no.
[5]	InCap	R	1	Input support: 1 = yes 0 = no.
[4]	OutCap	R	1	Output support: 1 = yes 0 = no.
[3]	HdphDrvCap	R	0	Headphone amp present: 1 = yes 0 = no.
[2]	PresDtctCap	R	1	Presence detection support: 1 = yes 0 = no.
[1]	TrigRqd	R	1	Trigger required for impedance sense: 1 = yes 0 = no.
[0]	ImpSenseCap	R	0	Impedance sense support: 1 = yes 0 = no.

5.7.3. PortE ConLst

	Verb ID	Payload	Response
Get	F00	0E	See bitfield table.

5.7.3.1. PortE ConLst

Bit	Bitfield Name	RW	Reset	Description
[31..8]	Rsvd	R	000000	Reserved.
[7]	LForm	R	0	Connection list format: 1 = long-form (15-bit) NID entries 0 = short-form (7-bit) NID entries.
[6..0]	ConL	R	03	Number of NID entries in connection list.

5.7.4. PortE ConLstEntry0

	Verb ID	Payload	Response
Get	F02	00	See bitfield table.

5.7.4.1. PortE ConLstEntry0

Bit	Bitfield Name	RW	Reset	Description
[31..24]	ConL3	R	00	Unused list entry.
[23..16]	ConL2	R	1E	MixerOutVol Summing widget (0x1E)
[15]	ConL1Range	R	1	1 = ConL0..ConL1 defines a range of selectable inputs.
[15..8]	ConL1	R	19	DAC4 Converter widget (0x19)
[7..0]	ConL0	R	15	DAC0 Converter widget (0x15)

5.7.5. PortE ConSelectCtrl

	Verb ID	Payload	Response
Get	F01	00	See bitfield table.

5.7.5.1. PortE ConSelectCtrl

Bit	Bitfield Name	RW	Reset	Description
[31..2]	Rsvd	R	00000000	Reserved.
[1..0]	Index	RW	0	Connection select control index.

5.7.6. PortE PinWCntrl

	Verb ID	Payload	Response
Get	F07	00	See bitfield table.

5.7.6.1. PortE PinWCntrl

Bit	Bitfield Name	RW	Reset	Description
[31..6]	Rsvd2	R	00000000	Reserved.
[5]	InEn	RW	0	Input enable: 1 = enabled 0 = disabled.
[4..3]	Rsvd1	R	0	Reserved.
[2..0]	VRefEn	RW	0	Vref selection (See VrefCntrl field of PinCap parameter for supported selections): 000b= HI-Z; 001b= 50%; 010b= GND; 011b= Reserved; 100b= 80%; 101b= 100%; 110b= Reserved; 111b= Reserved

5.7.7. PortE UnsolResp

	Verb ID	Payload	Response
Get	F08	00	See bitfield table.

5.7.7.1. *PortE UnsolResp*

Bit	Bitfield Name	RW	Reset	Description
[31.:8]	Rsvd2	R	000000	Reserved.
[7]	En	RW	0	Unsolicited response enable: 1 = enabled 0 = disabled.
[6]	Rsvd1	R	0	Reserved.
[5.:0]	Tag	RW	00	Software programmable field returned in top six bits (31:26) of every Unsolicited Response generated by this node.

5.7.8. *PortE ChSense*

	Verb ID	Payload	Response
Get	F09	00	See bitfield table.

5.7.8.1. *PortD ChSense*

Bit	Bitfield Name	RW	Reset	Description
[31]	PresDtct	R	0	Presence detection indicator: 1 = presence detected; 0 = presence not detected.
[30.:1]	Impedence	R	3FFFFFFh	Impedance Sense Value (Bits 30:1): Measured impedance of the widget. An all ones value indicates an invalid sense reading
[0]	Execute	RW	1	Impedance Sense Value (Bit 0)/Trigger: Read = Impedance value bit 0 Write 0 = Impedance sense occurs using left channel Write 1 = Impedance sense occurs using right channel

5.7.9. *PortE InAmpLeft*

	Verb ID	Payload	Response
Get	B20	00	See bitfield table.

5.7.9.1. *PortE InAmpLeft*

Bit	Bitfield Name	RW	Reset	Description
[31..2]	Rsvd1	R	000000	Reserved.
[1..0]	Gain	RW	0	Amp gain step number (see InAmpCap parameter pertaining to this widget).

5.7.10. *PortE InAmpRight*

	Verb ID	Payload	Response
Get	B00	00	See bitfield table.

5.7.10.1. *PortE InAmpRight*

Bit	Bitfield Name	RW	Reset	Description
[31..2]	Rsvd1	R	000000	Reserved.
[1..0]	Gain	RW	0	Amp gain step number (see InAmpCap parameter pertaining to this widget).

5.7.11. *PortE ConfigDefault*

	Verb ID	Payload	Response
Get	F1C	00	See bitfield table.

5.7.11.1. PortE ConfigDefault

Bit	Bitfield Name	RW	Reset	Description
[31..:30]	PortConnectivity	RW	0	Port connectivity: 0h = Port complex is connected to a jack; 1h = No physical connection for port; 2h = Fixed function device is attached; 3h = Both jack and internal device attached (info in all other fields refers to integrated device any presence detection refers to jack)
[29..:24]	Location	RW	1	Location. Bits [5..4]: 0h = External on primary chassis; 1h = Internal; 2h = Separate chassis; 3h = Other. Bits [3..0]: 0h = N/A; 1h = Rear; 2h = Front; 3h = Left; 4h = Right; 5h = Top; 6h = Bottom; 7h-9h = Special; Ah-Fh = Reserved
[23..:20]	Device	RW	A	Default device: 0h = Line out; 1h = Speaker; 2h = HP out; 3h = CD; 4h = SPDIF Out; 5h = Digital other out; 6h = Modem line side; 7h = Modem handset side; 8h = Line in; 9h = Aux; Ah = Mic in; Bh = Telephony; Ch = SPDIF In; Dh = Digital other in; Eh = Reserved; Fh = Other
[19..:16]	ConnectionType	RW	1	Connection type: 0h = Unknown; 1h = 1/8" stereo/mono; 2h = 1/4" stereo/mono; 3h = ATAPI internal; 4h = RCA; 5h = Optical; 6h = Other digital; 7h = Other analog; 8h = Multichannel analog (DIN); 9h = XLR/Professional; Ah = RJ-11 (modem); Bh = Combination; Ch-Eh = Reserved; Fh = Other
[15..:12]	Color	RW	9	Color: 0h = Unknown; 1h = Black; 2h = Grey; 3h = Blue; 4h = Green; 5h = Red; 6h = Orange; 7h = Yellow; 8h = Purple; 9h = Pink; Ah-Dh = Reserved; Eh = White; Fh = Other
[11..:8]	Misc	RW	0	Miscellaneous: Bits [3..1] = Reserved; Bit 0 = Jack detect override
[7..:4]	Association	RW	2	Default association.
[3..:0]	Sequence	RW	0	Sequence.

5.8. PortF Node (NID = 0F)

5.8.1. PortF WCap

	Verb ID	Payload	Response
Get	F00	09	See bitfield table.

5.8.1.1. PortF WCap

Bit	Bitfield Name	RW	Reset	Description
[31..24]	Rsvd2	R	00	Reserved.
[23..20]	Type	R	4	Widget type: 0h = Out Converter; 1h = In Converter; 2h = Summing (Mixer); 3h = Selector (Mux); 4h = Pin Complex; 5h = Power; 6h = Volume Knob; 7h = Beep Generator; 8h-Eh = Reserved; Fh = Vendor Defined
[19..16]	Delay	R	0	Number of sample delays through widget.
[15..12]	Rsvd1	R	0	Reserved.
[11]	SwapCap	R	0	Left/right swap support: 1 = yes 0 = no.
[10]	PwrCntrl	R	0	Power state support: 1 = yes 0 = no.
[9]	Dig	R	0	Digital stream support: 1 = yes (digital) 0 = no (analog).
[8]	ConnList	R	1	Connection list present: 1 = yes 0 = no.
[7]	UnSolCap	R	1	Unsolicited response support: 1 = yes 0 = no.
[6]	ProcWidget	R	0	Processing state support: 1 = yes 0 = no.
[5]	Stripe	R	0	Striping support: 1 = yes 0 = no.
[4]	FormatOvrd	R	0	Stream format override: 1 = yes 0 = no.
[3]	AmpParOvrd	R	0	Amplifier capabilities override: 1 = yes no.
[2]	OutAmpPrsnt	R	0	Output amp present: 1 = yes 0 = no.

5.8.1.1. *PortF WCap*

Bit	Bitfield Name	RW	Reset	Description
[1]	InAmpPrsnt	R	1	Input amp present: 1 = yes 0 = no.
[0]	Stereo	R	1	Stereo stream support: 1 = yes (stereo) 0 = no (mono).

5.8.2. *PortF PinCap*

	Verb ID	Payload	Response
Get	F00	0C	See bitfield table.

5.8.2.1. *PortF PinCap*

Bit	Bitfield Name	RW	Reset	Description
[31..17]	Rsvd2	R	0000	Reserved.
[16]	EapdCap	R	0	EAPD support: 1 = yes 0 = no.
[15..8]	VrefCntrl	R	00	Vref support: bit 7 = Reserved; bit 6 = Reserved; bit 5 = 100% support (1 = yes 0 = no); bit 4 = 80% support (1 = yes 0 = no); bit 3 = Reserved; bit 2 = GND support (1 = yes 0 = no); bit 1 = 50% support (1 = yes 0 = no); bit 0 = Hi-Z support (1 = yes 0 = no)
[7]	Rsvd1	R	0	Reserved.
[6]	BalancedIO	R	0	Balanced I/O support: 1 = yes 0 = no.
[5]	InCap	R	1	Input support: 1 = yes 0 = no.
[4]	OutCap	R	1	Output support: 1 = yes 0 = no.
[3]	HdphDrvCap	R	0	Headphone amp present: 1 = yes 0 = no.
[2]	PresDtctCap	R	1	Presence detection support: 1 = yes 0 = no.
[1]	TrigRqd	R	1	Trigger required for impedance sense: 1 = yes 0 = no.
[0]	ImpSenseCap	R	1	Impedance sense support: 1 = yes 0 = no.

5.8.3. *PortF ConLst*

	Verb ID	Payload	Response
Get	F00	0E	See bitfield table.

5.8.3.1. *PortF ConLst*

Bit	Bitfield Name	RW	Reset	Description
[31..8]	Rsvd	R	000000	Reserved.
[7]	LForm	R	0	Connection list format: 1 = long-form (15-bit) NID entries 0 = short-form (7-bit) NID entries.
[6..0]	ConL	R	03	Number of NID entries in connection list.

5.8.4. *PortF ConLstEntry0*

	Verb ID	Payload	Response
Get	F02	00	See bitfield table.

5.8.4.1. *PortF ConLstEntry0*

Bit	Bitfield Name	RW	Reset	Description
[31..24]	ConL3	R	00	Unused list entry.
[23..16]	ConL2	R	17	InputMixer Summing widget (0x17)
[15]	ConL1Range	R	1	1 = ConL0..ConL1 defines a range of selectable inputs.
[14..8]	ConL1	R	11	DAC1 Converter widget (0x11)
[7..0]	ConL0	R	10	DAC0 Converter widget (0x10)

5.8.5. PortF ConSelectCtrl

	Verb ID	Payload	Response
Get	F01	00	See bitfield table.

5.8.5.1. PortF ConSelectCtrl

Bit	Bitfield Name	RW	Reset	Description
[31.:2]	Rsvd	R	00000000	Reserved.
[1.:0]	Index	RW	0	Connection select control index.

5.8.6. PortF PinWCntrl

	Verb ID	Payload	Response
Get	F07	00	See bitfield table.

5.8.6.1. PortF PinWCntrl

Bit	Bitfield Name	RW	Reset	Description
[31.:7]	Rsvd2	R	000000	Reserved.
[6]	OutEn	RW	0	Output enable: 1 = enabled 0 = disabled.
[5]	InEn	RW	0	input enable: 1 = enabled 0 = disabled.
[4.:0]	Rsvd1	R	0	Reserved.

5.8.7. PortF UnsolResp

	Verb ID	Payload	Response
Get	F08	00	See bitfield table.

5.8.7.1. *PortF UnsolResp*

Bit	Bitfield Name	RW	Reset	Description
[31.:8]	Rsvd2	R	000000	Reserved.
[7]	En	RW	0	Unsolicited response enable: 1 = enabled 0 = disabled.
[6]	Rsvd1	R	0	Reserved.
[5.:0]	Tag	RW	00	Software programmable field returned in top six bits (31:26) of every Unsolicited Response generated by this node.

5.8.8. *PortF ChSense*

	Verb ID	Payload	Response
Get	F09	00	See bitfield table.

5.8.8.1. *PortF ChSense*

Bit	Bitfield Name	RW	Reset	Description
[31]	PresDtct	R	0	Presence detection indicator: 1 = presence detected; 0 = presence not detected.
[30.:1]	Impedence	R	3FFFFFFFh	Impedance Sense Value (Bits 30:1): Measured impedance of the widget. An all ones value indicates an invalid sense reading
[0]	Execute	RW	1	Impedance Sense Value (Bit 0)/Trigger: Read = Impedance value bit 0 Write 0 = Impedance sense occurs using left channel Write 1 = Impedance sense occurs using right channel

5.8.9. *PortF InAmpLeft*

	Verb ID	Payload	Response
Get	B20	00	See bitfield table.

5.8.9.1. *PortF InAmpLeft*

Bit	Bitfield Name	RW	Reset	Description
[31..2]	Rsvd1	R	000000	Reserved.
[1..0]	Gain	RW	0	Amp gain step number (see InAmpCap parameter pertaining to this widget).

5.8.10. *PortF InAmpRight*

	Verb ID	Payload	Response
Get	B00	00	See bitfield table.

5.8.10.1. *PortF InAmpRight*

Bit	Bitfield Name	RW	Reset	Description
[31..2]	Rsvd1	R	000000	Reserved.
[1..0]	Gain	RW	0	Amp gain step number (see InAmpCap parameter pertaining to this widget).

5.9. **PortG Node (NID = 10)**

5.9.1. *PortG WCap*

	Verb ID	Payload	Response
Get	F00	09	See bitfield table.

5.9.1.1. PortG WCap

Bit	Bitfield Name	RW	Reset	Description
[31.:24]	Rsvd2	R	00	Reserved.
[23.:20]	Type	R	4	Widget type: 0h = Out Converter; 1h = In Converter; 2h = Summing (Mixer); 3h = Selector (Mux); 4h = Pin Complex; 5h = Power; 6h = Volume Knob; 7h = Beep Generator; 8h-Eh = Reserved; Fh = Vendor Defined
[19.:16]	Delay	R	0	Number of sample delays through widget.
[15.:12]	Rsvd1	R	0	Reserved.
[11]	SwapCap	R	0	Left/right swap support: 1 = yes 0 = no.
[10]	PwrCntrl	R	0	Power state support: 1 = yes 0 = no.
[9]	Dig	R	0	Digital stream support: 1 = yes (digital) 0 = no (analog).
[8]	ConnList	R	1	Connection list present: 1 = yes 0 = no.
[7]	UnSolCap	R	1	Unsolicited response support: 1 = yes 0 = no.
[6]	ProcWidget	R	0	Processing state support: 1 = yes 0 = no.
[5]	Stripe	R	0	Striping support: 1 = yes 0 = no.
[4]	FormatOvrd	R	0	Stream format override: 1 = yes 0 = no.
[3]	AmpParOvrd	R	0	Amplifier capabilities override: 1 = yes no.
[2]	OutAmpPrsnt	R	0	Output amp present: 1 = yes 0 = no.
[1]	InAmpPrsnt	R	1	Input amp present: 1 = yes 0 = no.
[0]	Stereo	R	1	Stereo stream support: 1 = yes (stereo) 0 = no (mono).

5.9.2. PortG PinCap

	Verb ID	Payload	Response
Get	F00	0C	See bitfield table.

5.9.2.1. PortG PinCap

Bit	Bitfield Name	RW	Reset	Description
[31..17]	Rsvd2	R	0000	Reserved.
[16]	EapdCap	R	0	EAPD support: 1 = yes 0 = no.
[15..8]	VrefCntrl	R	00	Vref support: bit 7 = Reserved; bit 6 = Reserved; bit 5 = 100% support (1 = yes 0 = no); bit 4 = 80% support (1 = yes 0 = no); bit 3 = Reserved; bit 2 = GND support (1 = yes 0 = no); bit 1 = 50% support (1 = yes 0 = no); bit 0 = Hi-Z support (1 = yes 0 = no)
[7]	Rsvd1	R	0	Reserved.
[6]	BalancedIO	R	0	Balanced I/O support: 1 = yes 0 = no.
[5]	InCap	R	1	Input support: 1 = yes 0 = no.
[4]	OutCap	R	1	Output support: 1 = yes 0 = no.
[3]	HdphDrvCap	R	0	Headphone amp present: 1 = yes 0 = no.
[2]	PresDtctCap	R	1	Presence detection support: 1 = yes 0 = no.
[1]	TrigRqd	R	1	Trigger required for impedance sense: 1 = yes 0 = no.
[0]	ImpSenseCap	R	1	Impedance sense support: 1 = yes 0 = no.

5.9.3. PortG ConLst

	Verb ID	Payload	Response
Get	F00	0E	See bitfield table.

5.9.3.1. *PortG ConLst*

Bit	Bitfield Name	RW	Reset	Description
[31.:8]	Rsvd	R	000000	Reserved.
[7]	LForm	R	0	Connection list format: 1 = long-form (15-bit) NID entries 0 = short-form (7-bit) NID entries.
[6.:0]	ConL	R	03	Number of NID entries in connection list.

5.9.4. *PortG ConLstEntry0*

	Verb ID	Payload	Response
Get	F02	00	See bitfield table.

5.9.4.1. *PortG ConLstEntry0*

Bit	Bitfield Name	RW	Reset	Description
[31.:24]	ConL3	R	00	Unused list entry.
[23.:16]	ConL2	R	1E	MixerOutVol Selector widget (0x1E)
[15]	ConL1Range	R	1	1 = ConL0..ConL1 defines a range of selectable inputs.
[14.:8]	ConL1	R	19	DAC4 Converter widget (0x19)
[7.:0]	ConL0	R	15	DAC0 Converter widget (0x15)

5.9.5. *PortG ConSelectCtrl*

	Verb ID	Payload	Response
Get	F01	00	See bitfield table.

5.9.5.1. *PortG ConSelectCtrl*

Bit	Bitfield Name	RW	Reset	Description
[31..2]	Rsvd	R	00000000	Reserved.
[1..0]	Index	RW	0	Connection select control index.

5.9.6. *PortG PinWCntrl*

	Verb ID	Payload	Response
Get	F07	00	See bitfield table.

5.9.6.1. *PortG PinWCntrl*

Bit	Bitfield Name	RW	Reset	Description
[31..7]	Rsvd2	R	000000	Reserved.
[6]	OutEn	RW	0	Output enable: 1 = enabled 0 = disabled.
[5]	InEn	RW	0	input enable: 1 = enabled 0 = disabled.
[4..0]	Rsvd1	R	0	Reserved.

5.9.7. *PortG UnsolResp*

	Verb ID	Payload	Response
Get	F08	00	See bitfield table.

5.9.7.1. *PortG UnsolResp*

Bit	Bitfield Name	RW	Reset	Description
[31..8]	Rsvd2	R	000000	Reserved.
[7]	En	RW	0	Unsolicited response enable: 1 = enabled 0 = disabled.

5.9.7.1. *PortG UnsolResp*

Bit	Bitfield Name	RW	Reset	Description
[6]	Rsvd1	R	0	Reserved.
[5.:0]	Tag	RW	00	Software programmable field returned in top six bits (31:26) of every Unsolicited Response generated by this node.

5.9.8. *PortG ChSense*

	Verb ID	Payload	Response
Get	F09	00	See bitfield table.

5.9.8.1. *PortG ChSense*

Bit	Bitfield Name	RW	Reset	Description
[31]	PresDtct	R	0	Presence detection indicator: 1 = presence detected; 0 = presence not detected.
[30.:1]	Impedence	R	3FFFFFFh	Impedance Sense Value (Bits 30:1): Measured impedance of the widget. An all ones value indicates an invalid sense reading
[0]	Execute	RW	1	Impedance Sense Value (Bit 0)/Trigger: Read = Impedance value bit 0 Write 0 = Impedance sense occurs using left channel Write 1 = Impedance sense occurs using right channel

5.9.9. *PortG InAmpLeft*

	Verb ID	Payload	Response
Get	B20	00	See bitfield table.

5.9.9.1. *PortG InAmpLeft*

Bit	Bitfield Name	RW	Reset	Description
[31.:2]	Rsvd1	R	000000	Reserved.
[1.:0]	Gain	RW	0	Amp gain step number (see InAmpCap parameter pertaining to this widget).

5.9.10. *PortG InAmpRight*

	Verb ID	Payload	Response
Get	B00	00	See bitfield table.

5.9.10.1. *PortG InAmpRight*

Bit	Bitfield Name	RW	Reset	Description
[31.:2]	Rsvd1	R	000000	Reserved.
[1.:0]	Gain	RW	0	Amp gain step number (see InAmpCap parameter pertaining to this widget).

5.9.11. PortG ConfigDefault

	Verb ID	Payload	Response
Get	F1C	00	See bitfield table.

5.9.11.1. PortG ConfigDefault

Bit	Bitfield Name	RW	Reset	Description
[31..30]	PortConnectivity	RW	0	Port connectivity: 0h = Port complex is connected to a jack; 1h = No physical connection for port; 2h = Fixed function device is attached; 3h = Both jack and internal device attached (info in all other fields refers to integrated device any presence detection refers to jack)
[29..24]	Location	RW	01	Location. Bits [5..4]: 0h = External on primary chassis; 1h = Internal; 2h = Separate chassis; 3h = Other. Bits [3..0]: 0h = N/A; 1h = Rear; 2h = Front; 3h = Left; 4h = Right; 5h = Top; 6h = Bottom; 7h-9h = Special; Ah-Fh = Reserved
[23..20]	Device	RW	0	Default device: 0h = Line out; 1h = Speaker; 2h = HP out; 3h = CD; 4h = SPDIF Out; 5h = Digital other out; 6h = Modem line side; 7h = Modem handset side; 8h = Line in; 9h = Aux; Ah = Mic in; Bh = Telephony; Ch = SPDIF In; Dh = Digital other in; Eh = Reserved; Fh = Other
[19..16]	ConnectionType	RW	1	Connection type: 0h = Unknown; 1h = 1/8" stereo/mono; 2h = 1/4" stereo/mono; 3h = ATAPI internal; 4h = RCA; 5h = Optical; 6h = Other digital; 7h = Other analog; 8h = Multichannel analog (DIN); 9h = XLR/Professional; Ah = RJ-11 (modem); Bh = Combination; Ch-Eh = Reserved; Fh = Other
[15..12]	Color	RW	6	Color: 0h = Unknown; 1h = Black; 2h = Grey; 3h = Blue; 4h = Green; 5h = Red; 6h = Orange; 7h = Yellow; 8h = Purple; 9h = Pink; Ah-Dh = Reserved; Eh = White; Fh = Other
[11..8]	Misc	RW	0	Miscellaneous: Bits [3..1] = Reserved; Bit 0 = Jack detect override

5.9.11.1. *PortG ConfigDefault*

Bit	Bitfield Name	RW	Reset	Description
[7.:4]	Association	RW	1	Default association.
[3.:0]	Sequence	RW	1	Sequence.

5.10. **PortH Node (NID = 11)**5.10.1. *PortH WCap*

	Verb ID	Payload	Response
Get	F00	09	See bitfield table.

5.10.1.1. *PortH WCap*

Bit	Bitfield Name	RW	Reset	Description
[31.:24]	Rsvd2	R	00	Reserved.
[23.:20]	Type	R	4	Widget type: 0h = Out Converter; 1h = In Converter; 2h = Summing (Mixer); 3h = Selector (Mux); 4h = Pin Complex; 5h = Power; 6h = Volume Knob; 7h = Beep Generator; 8h-Eh = Reserved; Fh = Vendor Defined
[19.:16]	Delay	R	0	Number of sample delays through widget.
[15.:12]	Rsvd1	R	0	Reserved.
[11]	SwapCap	R	0	Left/right swap support: 1 = yes 0 = no.
[10]	PwrCntrl	R	0	Power state support: 1 = yes 0 = no.
[9]	Dig	R	0	Digital stream support: 1 = yes (digital) 0 = no (analog).
[8]	ConnList	R	1	Connection list present: 1 = yes 0 = no.
[7]	UnSolCap	R	1	Unsolicited response support: 1 = yes 0 = no.
[6]	ProcWidget	R	0	Processing state support: 1 = yes 0 = no.

5.10.1.1. *Porth WCap*

Bit	Bitfield Name	RW	Reset	Description
[5]	Stripe	R	0	Striping support: 1 = yes 0 = no.
[4]	FormatOvrd	R	0	Stream format override: 1 = yes 0 = no.
[3]	AmpParOvrd	R	0	Amplifier capabilities override: 1 = yes no.
[2]	OutAmpPrsnt	R	0	Output amp present: 1 = yes 0 = no.
[1]	InAmpPrsnt	R	1	Input amp present: 1 = yes 0 = no.
[0]	Stereo	R	1	Stereo stream support: 1 = yes (stereo) 0 = no (mono).

5.10.2. *Porth PinCap*

	Verb ID	Payload	Response
Get	F00	0C	See bitfield table.

5.10.2.1. *Porth PinCap*

Bit	Bitfield Name	RW	Reset	Description
[31.:17]	Rsvd2	R	0000	Reserved.
[16]	EapdCap	R	0	EAPD support: 1 = yes 0 = no.
[15.:8]	VrefCntrl	R	00	Vref support: bit 7 = Reserved; bit 6 = Reserved; bit 5 = 100% support (1 = yes 0 = no); bit 4 = 80% support (1 = yes 0 = no); bit 3 = Reserved; bit 2 = GND support (1 = yes 0 = no); bit 1 = 50% support (1 = yes 0 = no); bit 0 = Hi-Z support (1 = yes 0 = no)
[7]	Rsvd1	R	0	Reserved.
[6]	BalancedIO	R	0	Balanced I/O support: 1 = yes 0 = no.
[5]	InCap	R	1	Input support: 1 = yes 0 = no.
[4]	OutCap	R	1	Output support: 1 = yes 0 = no.
[3]	HdphDrvCap	R	0	Headphone amp present: 1 = yes 0 = no.

5.10.2.1. *Porth PinCap*

Bit	Bitfield Name	RW	Reset	Description
[2]	PresDtctCap	R	1	Presence detection support: 1 = yes 0 = no.
[1]	TrigRqd	R	1	Trigger required for impedance sense: 1 = yes 0 = no.
[0]	ImpSenseCap	R	1	Impedance sense support: 1 = yes 0 = no.

5.10.3. *Porth ConLst*

	Verb ID	Payload	Response
Get	F00	0E	See bitfield table.

5.10.3.1. *Porth ConLst*

Bit	Bitfield Name	RW	Reset	Description
[31.:8]	Rsvd	R	000000	Reserved.
[7]	LForm	R	0	Connection list format: 1 = long-form (15-bit) NID entries 0 = short-form (7-bit) NID entries.
[6.:0]	ConL	R	03	Number of NID entries in connection list.

5.10.4. *Porth ConLstEntry0*

	Verb ID	Payload	Response
Get	F02	00	See bitfield table.

5.10.4.1. *Porth ConLstEntry0*

Bit	Bitfield Name	RW	Reset	Description
[31.:24]	ConL3	R	00	Unused list entry.
[23.:16]	ConL2	R	1Eh	MixerOutVol Selector widget (0x1E)

5.10.4.1. *Porth ConLstEntry0*

Bit	Bitfield Name	RW	Reset	Description
[15]	ConL1Range	R	1	1 = ConL0..ConL1 defines a range of selectable inputs.
[14..8]	ConL1	R	19	DAC4 Converter widget (0x19)
[7..0]	ConL0	R	15	DAC0 Converter widget (0x15)

5.10.5. *Porth ConSelectCtrl*

	Verb ID	Payload	Response
Get	F01	00	See bitfield table.

5.10.5.1. *Porth ConSelectCtrl*

Bit	Bitfield Name	RW	Reset	Description
[31..2]	Rsvd	R	00000000	Reserved.
[1..0]	Index	RW	0	Connection select control index.

5.10.6. *Porth PinWCntrl*

	Verb ID	Payload	Response
Get	F07	00	See bitfield table.

5.10.6.1. *Porth PinWCntrl*

Bit	Bitfield Name	RW	Reset	Description
[31..7]	Rsvd2	R	000000	Reserved.
[6]	OutEn	RW	0	Output enable: 1 = enabled 0 = disabled.
[5]	InEn	RW	0	input enable: 1 = enabled 0 = disabled.
[4..0]	Rsvd1	R	0	Reserved.

5.10.7. Porth UnsolResp

	Verb ID	Payload	Response
Get	F08	00	See bitfield table.

5.10.7.1. Porth UnsolResp

Bit	Bitfield Name	RW	Reset	Description
[31..8]	Rsvd2	R	000000	Reserved.
[7]	En	RW	0	Unsolicited response enable: 1 = enabled 0 = disabled.
[6]	Rsvd1	R	0	Reserved.
[5..0]	Tag	RW	00	Software programmable field returned in top six bits (31:26) of every Unsolicited Response generated by this node.

5.10.8. Porth ChSense

	Verb ID	Payload	Response
Get	F09	00	See bitfield table.

5.10.8.1. Porth ChSense

Bit	Bitfield Name	RW	Reset	Description
[31]	PresDtct	R	0	Presence detection indicator: 1 = presence detected; 0 = presence not detected.
[30..1]	Impedence	R	3FFFFFFh	Impedance Sense Value (Bits 30:1): Measured impedance of the widget. An all ones value indicates an invalid sense reading
[0]	Execute	RW	1	Impedance Sense Value (Bit 0)/Trigger: Read = Impedance value bit 0 Write 0 = Impedance sense occurs using left channel Write 1 = Impedance sense occurs using right channel

5.10.9. Porth InAmpLeft

	Verb ID	Payload	Response
Get	B20	00	See bitfield table.

5.10.9.1. Porth InAmpLeft

Bit	Bitfield Name	RW	Reset	Description
[31..2]	Rsvd1	R	000000	Reserved.
[1..0]	Gain	RW	0	Amp gain step number (see InAmpCap parameter pertaining to this widget).

5.10.10. Porth InAmpRight

	Verb ID	Payload	Response
Get	B00	00	See bitfield table.

5.10.10.1. Porth InAmpRight

Bit	Bitfield Name	RW	Reset	Description
[31..2]	Rsvd1	R	000000	Reserved.
[1..0]	Gain	RW	0	Amp gain step number (see InAmpCap parameter pertaining to this widget).

5.10.11. Porth ConfigDefault

	Verb ID	Payload	Response
Get	F1C	00	See bitfield table.

5.10.11.1. Porth ConfigDefault

Bit	Bitfield Name	RW	Reset	Description
[31..30]	PortConnectivity	RW	0	Port connectivity: 0h = Port complex is connected to a jack; 1h = No physical connection for port; 2h = Fixed function device is attached; 3h = Both jack and internal device attached (info in all other fields refers to integrated device any presence detection refers to jack)
[29..24]	Location	RW	01	Location. Bits [5..4]: 0h = External on primary chassis; 1h = Internal; 2h = Separate chassis; 3h = Other. Bits [3..0]: 0h = N/A; 1h = Rear; 2h = Front; 3h = Left; 4h = Right; 5h = Top; 6h = Bottom; 7h-9h = Special; Ah-Fh = Reserved
[23..20]	Device	RW	0	Default device: 0h = Line out; 1h = Speaker; 2h = HP out; 3h = CD; 4h = SPDIF Out; 5h = Digital other out; 6h = Modem line side; 7h = Modem handset side; 8h = Line in; 9h = Aux; Ah = Mic in; Bh = Telephony; Ch = SPDIF In; Dh = Digital other in; Eh = Reserved; Fh = Other
[19..16]	ConnectionType	RW	1	Connection type: 0h = Unknown; 1h = 1/8" stereo/mono; 2h = 1/4" stereo/mono; 3h = ATAPI internal; 4h = RCA; 5h = Optical; 6h = Other digital; 7h = Other analog; 8h = Multichannel analog (DIN); 9h = XLR/Professional; Ah = RJ-11 (modem); Bh = Combination; Ch-Eh = Reserved; Fh = Other
[15..12]	Color	RW	2	Color: 0h = Unknown; 1h = Black; 2h = Grey; 3h = Blue; 4h = Green; 5h = Red; 6h = Orange; 7h = Yellow; 8h = Purple; 9h = Pink; Ah-Dh = Reserved; Eh = White; Fh = Other
[11..8]	Misc	RW	0	Miscellaneous: Bits [3..1] = Reserved; Bit 0 = Jack detect override

5.10.11.1. *PortH ConfigDefault*

Bit	Bitfield Name	RW	Reset	Description
[7.:4]	Association	RW	1	Default association.
[3.:0]	Sequence	RW	4	Sequence.

5.11. PortI Node (NID = 12)

5.11.1. *PortI WCap*

	Verb ID	Payload	Response
Get	F00	09	See bitfield table.

5.11.1.1. *PortI WCap*

Bit	Bitfield Name	RW	Reset	Description
[31.:24]	Rsvd2	R	00	Reserved.
[23.:20]	Type	R	4	Widget type: 0h = Out Converter; 1h = In Converter; 2h = Summing (Mixer); 3h = Selector (Mux); 4h = Pin Complex; 5h = Power; 6h = Volume Knob; 7h = Beep Generator; 8h-Eh = Reserved; Fh = Vendor Defined
[19.:16]	Delay	R	0	Number of sample delays through widget.
[15.:12]	Rsvd1	R	0	Reserved.
[11]	SwapCap	R	0	Left/right swap support: 1 = yes 0 = no.
[10]	PwrCntrl	R	0	Power state support: 1 = yes 0 = no.
[9]	Dig	R	0	Digital stream support: 1 = yes (digital) 0 = no (analog).
[8]	ConnList	R	0	Connection list present: 1 = yes 0 = no.
[7]	UnSolCap	R	1	Unsolicited response support: 1 = yes 0 = no.
[6]	ProcWidget	R	0	Processing state support: 1 = yes 0 = no.

5.11.1.1. *Port1 WCap*

Bit	Bitfield Name	RW	Reset	Description
[5]	Stripe	R	0	Striping support: 1 = yes 0 = no.
[4]	FormatOvrd	R	0	Stream format override: 1 = yes 0 = no.
[3]	AmpParOvrd	R	0	Amplifier capabilities override: 1 = yes no.
[2]	OutAmpPrsnt	R	0	Output amp present: 1 = yes 0 = no.
[1]	InAmpPrsnt	R	0	Input amp present: 1 = yes 0 = no.
[0]	Stereo	R	1	Stereo stream support: 1 = yes (stereo) 0 = no (mono).

5.11.2. *Port1 PinCap*

	Verb ID	Payload	Response
Get	F00	0C	See bitfield table.

5.11.2.1. *Port1 PinCap*

Bit	Bitfield Name	RW	Reset	Description
[31.:17]	Rsvd2	R	0000	Reserved.
[16]	EapdCap	R	0	EAPD support: 1 = yes 0 = no.
[15.:8]	VrefCntrl	R	00	Vref support: bit 7 = Reserved; bit 6 = Reserved; bit 5 = 100% support (1 = yes 0 = no); bit 4 = 80% support (1 = yes 0 = no); bit 3 = Reserved; bit 2 = GND support (1 = yes 0 = no); bit 1 = 50% support (1 = yes 0 = no); bit 0 = Hi-Z support (1 = yes 0 = no)
[7]	Rsvd1	R	0	Reserved.
[6]	BalancedIO	R	0	Balanced I/O support: 1 = yes 0 = no.
[5]	InCap	R	1	Input support: 1 = yes 0 = no.
[4]	OutCap	R	1	Output support: 1 = yes 0 = no.
[3]	HdphDrvCap	R	0	Headphone amp present: 1 = yes 0 = no.

5.11.2.1. *Port1 PinCap*

Bit	Bitfield Name	RW	Reset	Description
[2]	PresDtctCap	R	1	Presence detection support: 1 = yes 0 = no.
[1]	TrigRqd	R	1	Trigger required for impedance sense: 1 = yes 0 = no.
[0]	ImpSenseCap	R	1	Impedance sense support: 1 = yes 0 = no.

5.11.3. *Port1 PinWCntrl*

	Verb ID	Payload	Response
Get	F07	00	See bitfield table.

5.11.3.1. *Port1 PinWCntrl*

Bit	Bitfield Name	RW	Reset	Description
[31..6]	Rsvd2	R	000000	Reserved.
[5]	InEn	RW	0	input enable: 1 = enabled 0 = disabled.
[4..0]	Rsvd1	R	0	Reserved.

5.11.4. *Port1 UnsolResp*

	Verb ID	Payload	Response
Get	F08	00	See bitfield table.

5.11.4.1. *Port1 UnsolResp*

Bit	Bitfield Name	RW	Reset	Description
[31..8]	Rsvd2	R	000000	Reserved.
[7]	En	RW	0	Unsolicited response enable: 1 = enabled 0 = disabled.

5.11.4.1. *PortI UnsolicitedResponse*

Bit	Bitfield Name	RW	Reset	Description
[6]	Rsvd1	R	0	Reserved.
[5.:0]	Tag	RW	00	Software programmable field returned in top six bits (31:26) of every Unsolicited Response generated by this node.

5.11.5. *PortI ChSense*

	Verb ID	Payload	Response
Get	F09	00	See bitfield table.

5.11.5.1. *PortI ChSense*

Bit	Bitfield Name	RW	Reset	Description
[31]	PresDtct	R	0	Presence detection indicator: 1 = presence detected; 0 = presence not detected.
[30.:0]	Rsvd	R	00000000	Reserved

5.11.6. *PortI ConfigDefault*

	Verb ID	Payload	Response
Get	F1C	00	See bitfield table.

5.11.6.1. *PortH ConfigDefault*

Bit	Bitfield Name	RW	Reset	Description
[31.:30]	PortConnectivity	RW	2	Port connectivity: 0h = Port complex is connected to a jack; 1h = No physical connection for port; 2h = Fixed function device is attached; 3h = Both jack and internal device attached (info in all other fields refers to integrated device any presence detection refers to jack)
[29.:24]	Location	RW	19	Location. Bits [5..4]: 0h = External on primary chassis; 1h = Internal; 2h = Separate chassis; 3h = Other. Bits [3..0]: 0h = N/A; 1h = Rear; 2h = Front; 3h = Left; 4h = Right; 5h = Top; 6h = Bottom; 7h-9h = Special; Ah-Fh = Reserved
[23.:20]	Device	RW	3	Default device: 0h = Line out; 1h = Speaker; 2h = HP out; 3h = CD; 4h = SPDIF Out; 5h = Digital other out; 6h = Modem line side; 7h = Modem handset side; 8h = Line in; 9h = Aux; Ah = Mic in; Bh = Telephony; Ch = SPDIF In; Dh = Digital other in; Eh = Reserved; Fh = Other
[19.:16]	ConnectionType	RW	3	Connection type: 0h = Unknown; 1h = 1/8" stereo/mono; 2h = 1/4" stereo/mono; 3h = ATAPI internal; 4h = RCA; 5h = Optical; 6h = Other digital; 7h = Other analog; 8h = Multichannel analog (DIN); 9h = XLR/Professional; Ah = RJ-11 (modem); Bh = Combination; Ch-Eh = Reserved; Fh = Other
[15.:12]	Color	RW	0	Color: 0h = Unknown; 1h = Black; 2h = Grey; 3h = Blue; 4h = Green; 5h = Red; 6h = Orange; 7h = Yellow; 8h = Purple; 9h = Pink; Ah-Dh = Reserved; Eh = White; Fh = Other
[11.:8]	Misc	RW	1	Miscellaneous: Bits [3..1] = Reserved; Bit 0 = Jack detect override
[7.:4]	Association	RW	2	Default association.
[3.:0]	Sequence	RW	E	Sequence.

5.12. DMic0 Node (NID = 13)

5.12.1. DMic0 WCap

	Verb ID	Payload	Response
Get	F00	09	See bitfield table.

5.12.1.1. DMic0 WCap

Bit	Bitfield Name	RW	Reset	Description
[31..24]	Rsvd2	R	00	Reserved.
[23..20]	Type	R	4	Widget type: 0h = Out Converter; 1h = In Converter; 2h = Summing (Mixer); 3h = Selector (Mux); 4h = Pin Complex; 5h = Power; 6h = Volume Knob; 7h = Beep Generator; 8h-Eh = Reserved; Fh = Vendor Defined
[19..16]	Delay	R	0	Number of sample delays through widget.
[15..12]	Rsvd1	R	0	Reserved.
[11]	SwapCap	R	0	Left/right swap support: 1 = yes 0 = no.
[10]	PwrCntrl	R	0	Power state support: 1 = yes 0 = no.
[9]	DigitalStrm	R	0	Digital stream support: 1 = yes (digital) 0 = no (analog).
[8]	ConnList	R	0	Connection list present: 1 = yes 0 = no.
[7]	UnsolCap	R	0	Unsolicited response support: 1 = yes 0 = no.
[6]	ProcWidget	R	0	Processing state support: 1 = yes 0 = no.
[5]	Stripe	R	0	Striping support: 1 = yes 0 = no.
[4]	FormatOvrd	R	0	Stream format override: 1 = yes 0 = no.
[3]	AmpParOvrd	R	0	Amplifier capabilities override: 1 = yes no.
[2]	OutAmpPrsnt	R	0	Output amp present: 1 = yes 0 = no.

5.12.1.1. *DMic0 WCap*

Bit	Bitfield Name	RW	Reset	Description
[1]	InAmpPrsnt	R	1	Input amp present: 1 = yes 0 = no.
[0]	Stereo	R	1	Stereo stream support: 1 = yes (stereo) 0 = no (mono).

5.12.2. *DMic0 PinCap*

	Verb ID	Payload	Response
Get	F00	0C	See bitfield table.

5.12.2.1. *DMic0 PinCap*

Bit	Bitfield Name	RW	Reset	Description
[31..17]	Rsvd2	R	0000	Reserved.
[16]	EapdCap	R	0	EAPD support: 1 = yes 0 = no.
[15..8]	VRefCntrl	R	00	Vref support: bit 7 = Reserved; bit 6 = Reserved; bit 5 = 100% support (1 = yes 0 = no); bit 4 = 80% support (1 = yes 0 = no); bit 3 = Reserved; bit 2 = GND support (1 = yes 0 = no); bit 1 = 50% support (1 = yes 0 = no); bit 0 = Hi-Z support (1 = yes 0 = no)
[7]	Rsvd1	R	0	Reserved.
[6]	BalancedIO	R	0	Balanced I/O support: 1 = yes 0 = no.
[5]	InCap	R	1	Input support: 1 = yes 0 = no.
[4]	OutCap	R	0	Output support: 1 = yes 0 = no.
[3]	HPHnDrvCap	R	0	Headphone amp present: 1 = yes 0 = no.
[2]	PresDtctCap	R	0	Presence detection support: 1 = yes 0 = no.
[1]	TrigRqd	R	0	Trigger required for impedance sense: 1 = yes 0 = no.
[0]	ImpSenseCap	R	0	Impedance sense support: 1 = yes 0 = no.

5.12.3. DMic0 PinWCntrl

	Verb ID	Payload	Response
Get	F07	00	See bitfield table.

5.12.3.1. DMic0 PinWCntrl

Bit	Bitfield Name	RW	Reset	Description
[31..6]	Rsvd2	R	0000000	Reserved.
[5]	InEn	RW	0	Input enable: 1 = enabled 0 = disabled.
[4..0]	Rsvd1	R	00	Reserved.

5.12.4. DMic0 InAmpLeft

	Verb ID	Payload	Response
Get	B20	00	See bitfield table.

5.12.4.1. DMic0 InAmpLeft

Bit	Bitfield Name	RW	Reset	Description
[31..2]	Rsvd1	R	000000	Reserved.
[1..0]	Gain	RW	0	Amp gain step number (see InAmpCap parameter pertaining to this widget).

5.12.5. DMic0 InAmpRight

	Verb ID	Payload	Response
Get	B00	00	See bitfield table.

5.12.5.1. *DMic0 InAmpRight*

Bit	Bitfield Name	RW	Reset	Description
[31..2]	Rsvd1	R	000000	Reserved.
[1..0]	Gain	RW	0	Amp gain step number (see InAmpCap parameter pertaining to this widget).

5.12.6. *DMic0 ConfigDefault*

	Verb ID	Payload	Response
Get	F1C	00	See bitfield table.

5.12.6.1. *DMic0 ConfigDefault*

Bit	Bitfield Name	RW	Reset	Description
[31..30]	PortConnectivity	RW	2	Port connectivity: 0h = Port complex is connected to a jack; 1h = No physical connection for port; 2h = Fixed function device is attached; 3h = Both jack and internal device attached (info in all other fields refers to integrated device any presence detection refers to jack)
[29..24]	Location	RW	10	Location. Bits [5..4]: 0h = External on primary chassis; 1h = Internal; 2h = Separate chassis; 3h = Other. Bits [3..0]: 0h = N/A; 1h = Rear; 2h = Front; 3h = Left; 4h = Right; 5h = Top; 6h = Bottom; 7h-9h = Special; Ah-Fh = Reserved
[23..20]	Device	RW	A	Default device: 0h = Line out; 1h = Speaker; 2h = HP out; 3h = CD; 4h = SPDIF Out; 5h = Digital other out; 6h = Modem line side; 7h = Modem handset side; 8h = Line in; 9h = Aux; Ah = Mic in; Bh = Telephony; Ch = SPDIF In; Dh = Digital other in; Eh = Reserved; Fh = Other

5.12.6.1. *DMic0 ConfigDefault*

Bit	Bitfield Name	RW	Reset	Description
[19.:16]	ConnectionType	RW	3	Connection type: 0h = Unknown; 1h = 1/8" stereo/mono; 2h = 1/4" stereo/mono; 3h = ATAPI internal; 4h = RCA; 5h = Optical; 6h = Other digital; 7h = Other analog; 8h = Multichannel analog (DIN); 9h = XLR/Professional; Ah = RJ-11 (modem); Bh = Combination; Ch-Eh = Reserved; Fh = Other
[15.:12]	Color	RW	0	Color: 0h = Unknown; 1h = Black; 2h = Grey; 3h = Blue; 4h = Green; 5h = Red; 6h = Orange; 7h = Yellow; 8h = Purple; 9h = Pink; Ah-Dh = Reserved; Eh = White; Fh = Other
[11.:8]	Misc	RW	0	Miscellaneous: Bits [3..1] = Reserved; Bit 0 = Jack detect override
[7.:4]	Association	RW	7	Default association.
[3.:0]	Sequence	RW	0	Sequence.

5.13. **DMic1 Node (NID = 14)**5.13.1. *DMic1 WCap*

	Verb ID	Payload	Response
Get	F00	09	See bitfield table.

5.13.1.1. *DMic1 WCap*

Bit	Bitfield Name	RW	Reset	Description
[31.:24]	Rsvd2	R	00	Reserved.
[23.:20]	Type	R	4	Widget type: 0h = Out Converter; 1h = In Converter; 2h = Summing (Mixer); 3h = Selector (Mux); 4h = Pin Complex; 5h = Power; 6h = Volume Knob; 7h = Beep Generator; 8h-Eh = Reserved; Fh = Vendor Defined
[19.:16]	Delay	R	0	Number of sample delays through widget.

5.13.1.1. *DMic1 WCap*

Bit	Bitfield Name	RW	Reset	Description
[15.:12]	Rsvd1	R	0	Reserved.
[11]	SwapCap	R	0	Left/right swap support: 1 = yes 0 = no.
[10]	PwrCntrl	R	0	Power state support: 1 = yes 0 = no.
[9]	DigitalStrm	R	0	Digital stream support: 1 = yes (digital) 0 = no (analog).
[8]	ConnList	R	0	Connection list present: 1 = yes 0 = no.
[7]	UnsolCap	R	0	Unsolicited response support: 1 = yes 0 = no.
[6]	ProcWidget	R	0	Processing state support: 1 = yes 0 = no.
[5]	Stripe	R	0	Striping support: 1 = yes 0 = no.
[4]	FormatOvrd	R	0	Stream format override: 1 = yes 0 = no.
[3]	AmpParOvrd	R	0	Amplifier capabilities override: 1 = yes no.
[2]	OutAmpPrsnt	R	0	Output amp present: 1 = yes 0 = no.
[1]	InAmpPrsnt	R	1	Input amp present: 1 = yes 0 = no.
[0]	Stereo	R	1	Stereo stream support: 1 = yes (stereo) 0 = no (mono).

5.13.2. *DMic1 PinCap*

	Verb ID	Payload	Response
Get	F00	0C	See bitfield table.

5.13.2.1. *DMic1 PinCap*

Bit	Bitfield Name	RW	Reset	Description
[31.:17]	Rsvd2	R	0000	Reserved.
[16]	EapdCap	R	0	EAPD support: 1 = yes 0 = no.

5.13.2.1. *DMic1 PinCap*

Bit	Bitfield Name	RW	Reset	Description
[15.:8]	VRefCntrl	R	00	Vref support: bit 7 = Reserved; bit 6 = Reserved; bit 5 = 100% support (1 = yes 0 = no); bit 4 = 80% support (1 = yes 0 = no); bit 3 = Reserved; bit 2 = GND support (1 = yes 0 = no); bit 1 = 50% support (1 = yes 0 = no); bit 0 = Hi-Z support (1 = yes 0 = no)
[7]	Rsvd1	R	0	Reserved.
[6]	BalancedIO	R	0	Balanced I/O support: 1 = yes 0 = no.
[5]	InCap	R	1	Input support: 1 = yes 0 = no.
[4]	OutCap	R	0	Output support: 1 = yes 0 = no.
[3]	HPhnDrvCap	R	0	Headphone amp present: 1 = yes 0 = no.
[2]	PresDtctCap	R	0	Presence detection support: 1 = yes 0 = no.
[1]	TrigRqd	R	0	Trigger required for impedance sense: 1 = yes 0 = no.
[0]	ImpSenseCap	R	0	Impedance sense support: 1 = yes 0 = no.

5.13.3. *DMic1 PinWCntrl*

	Verb ID	Payload	Response
Get	F07	00	See bitfield table.

5.13.3.1. *DMic1 PinWCntrl*

Bit	Bitfield Name	RW	Reset	Description
[31.:6]	Rsvd2	R	0000000	Reserved.
[5]	InEn	RW	0	Input enable: 1 = enabled 0 = disabled.
[4.:0]	Rsvd1	R	00	Reserved.

5.13.4. DMic1 InAmpLeft

	Verb ID	Payload	Response
Get	B20	00	See bitfield table.

5.13.4.1. DMic1 InAmpLeft

Bit	Bitfield Name	RW	Reset	Description
[31..2]	Rsvd1	R	000000	Reserved.
[1..0]	Gain	RW	0	Amp gain step number (see InAmpCap parameter pertaining to this widget).

5.13.5. DMic1 InAmpRight

	Verb ID	Payload	Response
Get	B00	00	See bitfield table.

5.13.5.1. DMic1 InAmpRight

Bit	Bitfield Name	RW	Reset	Description
[31..2]	Rsvd1	R	000000	Reserved.
[1..0]	Gain	RW	0	Amp gain step number (see InAmpCap parameter pertaining to this widget).

5.13.6. DMic1 ConfigDefault

	Verb ID	Payload	Response
Get	F1C	00	See bitfield table.

5.13.6.1. DMic1 ConfigDefault

Bit	Bitfield Name	RW	Reset	Description
[31..:30]	PortConnectivity	RW	2	Port connectivity: 0h = Port complex is connected to a jack; 1h = No physical connection for port; 2h = Fixed function device is attached; 3h = Both jack and internal device attached (info in all other fields refers to integrated device any presence detection refers to jack)
[29..:24]	Location	RW	10	Location. Bits [5..4]: 0h = External on primary chassis; 1h = Internal; 2h = Separate chassis; 3h = Other. Bits [3..0]: 0h = N/A; 1h = Rear; 2h = Front; 3h = Left; 4h = Right; 5h = Top; 6h = Bottom; 7h-9h = Special; Ah-Fh = Reserved
[23..:20]	Device	RW	A	Default device: 0h = Line out; 1h = Speaker; 2h = HP out; 3h = CD; 4h = SPDIF Out; 5h = Digital other out; 6h = Modem line side; 7h = Modem handset side; 8h = Line in; 9h = Aux; Ah = Mic in; Bh = Telephony; Ch = SPDIF In; Dh = Digital other in; Eh = Reserved; Fh = Other
[19..:16]	ConnectionType	RW	3	Connection type: 0h = Unknown; 1h = 1/8" stereo/mono; 2h = 1/4" stereo/mono; 3h = ATAPI internal; 4h = RCA; 5h = Optical; 6h = Other digital; 7h = Other analog; 8h = Multichannel analog (DIN); 9h = XLR/Professional; Ah = RJ-11 (modem); Bh = Combination; Ch-Eh = Reserved; Fh = Other
[15..:12]	Color	RW	0	Color: 0h = Unknown; 1h = Black; 2h = Grey; 3h = Blue; 4h = Green; 5h = Red; 6h = Orange; 7h = Yellow; 8h = Purple; 9h = Pink; Ah-Dh = Reserved; Eh = White; Fh = Other
[11..:8]	Misc	RW	0	Miscellaneous: Bits [3..1] = Reserved; Bit 0 = Jack detect override
[7..:4]	Association	RW	7	Default association.
[3..:0]	Sequence	RW	E	Sequence.

5.14. DAC0 Node (NID = 15)

5.14.1. DAC0 WCap

	Verb ID	Payload	Response
Get	F00	09	See bitfield table.

5.14.1.1. DAC0 WCap

Bit	Bitfield Name	RW	Reset	Description
[31..24]	Rsvd2	R	00	Reserved.
[23..20]	Type	R	0	Widget type: 0h = Out Converter; 1h = In Converter; 2h = Summing (Mixer); 3h = Selector (Mux); 4h = Pin Complex; 5h = Power; 6h = Volume Knob; 7h = Beep Generator; 8h-Eh = Reserved; Fh = Vendor Defined
[19..16]	Delay	R	D	Number of sample delays through widget.
[15..12]	Rsvd1	R	0	Reserved.
[11]	SwapCap	R	1	Left/right swap support: 1 = yes 0 = no.
[10]	PwrCntrl	R	1	Power state support: 1 = yes 0 = no.
[9]	Dig	R	0	Digital stream support: 1 = yes (digital) 0 = no (analog).
[8]	ConnList	R	0	Connection list present: 1 = yes 0 = no.
[7]	UnSolCap	R	0	Unsolicited response support: 1 = yes 0 = no.
[6]	ProcWidget	R	0	Processing state support: 1 = yes 0 = no.
[5]	Stripe	R	0	Striping support: 1 = yes 0 = no.
[4]	FormatOvrd	R	0	Stream format override: 1 = yes 0 = no.
[3]	AmpParOvrd	R	0	Amplifier capabilities override: 1 = yes no.
[2]	OutAmpPrsnt	R	1	Output amp present: 1 = yes 0 = no.

5.14.1.1. *DAC0 WCap*

Bit	Bitfield Name	RW	Reset	Description
[1]	InAmpPrsnt	R	0	Input amp present: 1 = yes 0 = no.
[0]	Stereo	R	1	Stereo stream support: 1 = yes (stereo) 0 = no (mono).

5.14.2. *DAC0 Cnvtr*

	Verb ID	Payload	Response
Get	A	0000	See bitfield table.

5.14.2.1. *DAC0 Cnvtr*

Bit	Bitfield Name	RW	Reset	Description
[31.:16]	Rsvd2	R	0000	Reserved.
[15]	StrmType	R	0	Stream type: 1 = Non-PCM 0 = PCM.
[14]	FrmtSmplRate	RW	0	Sample base rate: 1 = 44.1kHz 0 = 48kHz.
[13.:11]	SmplRateMultp	RW	0	Sample base rate multiple: 000b= x1 (48kHz/44.1kHz or less); 001b= x2 (96kHz/88.2kHz/32kHz); 010b= x3 (144kHz); 011b= x4 (192kHz/176.4kHz); 100b-111b Reserved
[10.:8]	SmplRateDiv	RW	0	Sample base rate divider: 000b= Divide by 1 (48kHz/44.1kHz); 001b= Divide by 2 (24kHz/20.05kHz); 010b= Divide by 3 (16kHz/32kHz); 011b= Divide by 4 (11.025kHz); 100b= Divide by 5 (9.6kHz); 101b= Divide by 6 (8kHz); 110b= Divide by 7; 111b= Divide by 8 (6kHz)
[7]	Rsvd1	R	0	Reserved.

5.14.2.1. *DAC0 Cnvtr*

Bit	Bitfield Name	RW	Reset	Description
[6.:4]	BitsPerSmpl	RW	3	Bits per sample: 000b= 8 bits; 001b= 16 bits; 010b= 20 bits; 011b= 24 bits; 100b= 32 bits; 101b-111b= Reserved
[3.:0]	NmbrChan	RW	1	Total number of channels in the stream assigned to this converter: 0000b-1111b= 1-16 channels.

5.14.3. *DAC0 OutAmpLeft*

	Verb ID	Payload	Response
Get	BA0	00	See bitfield table.

5.14.3.1. *DAC0 OutAmpLeft*

Bit	Bitfield Name	RW	Reset	Description
[31.:8]	Rsvd	R	000000	Reserved.
[7]	Mute	RW	1	Amp mute: 1 = muted 0 = not muted.
[6.:0]	Gain	RW	7F	Amp gain step number (see OutAmp-Cap parameter pertaining to this widget).

5.14.4. *DAC0 OutAmpRight*

	Verb ID	Payload	Response
Get	B80	00	See bitfield table.

5.14.4.1. *DAC0 OutAmpRight*

Bit	Bitfield Name	RW	Reset	Description
[31.:8]	Rsvd	R	000000	Reserved.

5.14.4.1. *DAC0 OutAmpRight*

Bit	Bitfield Name	RW	Reset	Description
[7]	Mute	RW	1	Amp mute: 1 = muted 0 = not muted.
[6.:0]	Gain	RW	7F	Amp gain step number (see OutAmp-Cap parameter pertaining to this widget).

5.14.5. *DAC0 PwrState*

	Verb ID	Payload	Response
Get	F05	00	See bitfield table.

5.14.5.1. *DAC0 PwrState*

Bit	Bitfield Name	RW	Reset	Description
[31.:6]	Rsvd2	R	0000000	Reserved.
[5.:4]	Act	R	3	Actual power state of this widget.
[3.:2]	Rsvd1	R	0	Reserved.
[1.:0]	Set	RW	3	Current power state setting for this widget.

5.14.6. *DAC0 CnvtrID*

	Verb ID	Payload	Response
Get	F06	00	See bitfield table.

5.14.6.1. *DAC0 CnvtrID*

Bit	Bitfield Name	RW	Reset	Description
[31.:8]	Rsvd	R	000000	Reserved.

92HD73E

Ten Channel HD Audio Codec

5.14.6.1. DAC0 CnvtrID

Bit	Bitfield Name	RW	Reset	Description
[7.:4]	Strm	RW	0	Stream ID: 0h = Converter "off" 1h-Fh = valid IDs.
[3.:0]	Ch	RW	0	Channel assignment ("Ch" and "Ch+1" assigned as a pair for a stereo converter).

5.14.7. DAC0 LR

	Verb ID	Payload	Response
Get	F0C	00	See bitfield table.

5.14.7.1. DAC0 LR

Bit	Bitfield Name	RW	Reset	Description
[31.:3]	Rsvd2	R	00000000	Reserved.
[2]	SwapEn	RW	0	Swap enable: 1 = L/R swap enabled 0 = L/R swap disabled.
[1.:0]	Rsvd1	R	0	Reserved.

5.15. DAC1 Node (NID = 16)

5.15.1. DAC1 WCap

	Verb ID	Payload	Response
Get	F00	09	See bitfield table.

5.15.1.1. DAC1 WCap

Bit	Bitfield Name	RW	Reset	Description
[31.:24]	Rsvd2	R	00	Reserved.
[23.:20]	Type	R	0	Widget type: 0h = Out Converter; 1h = In Converter; 2h = Summing (Mixer); 3h = Selector (Mux); 4h = Pin Complex; 5h = Power; 6h = Volume Knob; 7h = Beep Generator; 8h-Eh = Reserved; Fh = Vendor Defined
[19.:16]	Delay	R	D	Number of sample delays through widget.
[15.:12]	Rsvd1	R	0	Reserved.
[11]	SwapCap	R	1	Left/right swap support: 1 = yes 0 = no.
[10]	PwrCntrl	R	1	Power state support: 1 = yes 0 = no.
[9]	Dig	R	0	Digital stream support: 1 = yes (digital) 0 = no (analog).
[8]	ConnList	R	0	Connection list present: 1 = yes 0 = no.
[7]	UnSolCap	R	0	Unsolicited response support: 1 = yes 0 = no.
[6]	ProcWidget	R	0	Processing state support: 1 = yes 0 = no.
[5]	Stripe	R	0	Striping support: 1 = yes 0 = no.
[4]	FormatOvrd	R	0	Stream format override: 1 = yes 0 = no.
[3]	AmpParOvrd	R	0	Amplifier capabilities override: 1 = yes no.
[2]	OutAmpPrsnt	R	1	Output amp present: 1 = yes 0 = no.
[1]	InAmpPrsnt	R	0	Input amp present: 1 = yes 0 = no.
[0]	Stereo	R	1	Stereo stream support: 1 = yes (stereo) 0 = no (mono).

5.15.2. DAC1 Cnvtr

	Verb ID	Payload	Response
Get	A00	00	See bitfield table.

5.15.2.1. DAC1 Cnvtr

Bit	Bitfield Name	RW	Reset	Description
[31..16]	Rsvd2	R	0000	Reserved.
[15]	StrmType	R	0	Stream type: 1 = Non-PCM 0 = PCM.
[14]	FrmtSmplRate	RW	0	Sample base rate: 1 = 44.1kHz 0 = 48kHz.
[13..11]	SmplRateMultp	RW	0	Sample base rate multiple: 000b= x1 (48kHz/44.1kHz or less); 001b= x2 (96kHz/88.2kHz/32kHz); 010b= x3 (144kHz); 011b= x4 (192kHz/176.4kHz); 100b-111b Reserved
[10..8]	SmplRateDiv	RW	0	Sample base rate divider: 000b= Divide by 1 (48kHz/44.1kHz); 001b= Divide by 2 (24kHz/20.05kHz); 010b= Divide by 3 (16kHz/32kHz); 011b= Divide by 4 (11.025kHz); 100b= Divide by 5 (9.6kHz); 101b= Divide by 6 (8kHz); 110b= Divide by 7; 111b= Divide by 8 (6kHz)
[7]	Rsvd1	R	0	Reserved.
[6..4]	BitsPerSmpl	RW	3	Bits per sample: 000b= 8 bits; 001b= 16 bits; 010b= 20 bits; 011b= 24 bits; 100b= 32 bits; 101b-111b= Reserved
[3..0]	NmbrChan	RW	1	Total number of channels in the stream assigned to this converter: 0000b-1111b= 1-16 channels.

5.15.3. DAC1 OutAmpLeft

	Verb ID	Payload	Response
Get	BA0	00	See bitfield table.

5.15.3.1. *DAC1 OutAmpLeft*

Bit	Bitfield Name	RW	Reset	Description
[31.:8]	Rsvd	R	000000	Reserved.
[7]	Mute	RW	1	Amp mute: 1 = muted 0 = not muted.
[6.:0]	Gain	RW	7F	Amp gain step number (see OutAmp-Cap parameter pertaining to this widget).

5.15.4. *DAC1 OutAmpRight*

	Verb ID	Payload	Response
Get	B80	00	See bitfield table.

5.15.4.1. *DAC1 OutAmpRight*

Bit	Bitfield Name	RW	Reset	Description
[31.:8]	Rsvd	R	000000	Reserved.
[7]	Mute	RW	1	Amp mute: 1 = muted 0 = not muted.
[6.:0]	Gain	RW	7F	Amp gain step number (see OutAmp-Cap parameter pertaining to this widget).

5.15.5. *DAC1 PwrState*

	Verb ID	Payload	Response
Get	F05	00	See bitfield table.

5.15.5.1. DAC1 PwrState

Bit	Bitfield Name	RW	Reset	Description
[31.:6]	Rsvd2	R	0000000	Reserved.
[5.:4]	Act	R	3	Actual power state of this widget.
[3.:2]	Rsvd1	R	0	Reserved.
[1.:0]	Set	RW	3	Current power state setting for this widget.

5.15.6. DAC1 CnvtrID

	Verb ID	Payload	Response
Get	F06	00	See bitfield table.

5.15.6.1. DAC1 CnvtrID

Bit	Bitfield Name	RW	Reset	Description
[31.:8]	Rsvd	R	000000	Reserved.
[7.:4]	Strm	RW	0	Stream ID: 0h = Converter "off" 1h-Fh = valid IDs.
[3.:0]	Ch	RW	0	Channel assignment ("Ch" and "Ch+1" assigned as a pair for a stereo converter).

5.15.7. DAC1 LR

	Verb ID	Payload	Response
Get	F0C	00	See bitfield table.

5.15.7.1. DAC1 LR

Bit	Bitfield Name	RW	Reset	Description
[31.:3]	Rsvd2	R	00000000	Reserved.
[2]	SwapEn	RW	0	Swap enable: 1 = L/R swap enabled 0 = L/R swap disabled.
[1.:0]	Rsvd1	R	0	Reserved.

5.16. DAC2 Node (NID = 17)

5.16.1. DAC2 WCap

	Verb ID	Payload	Response
Get	F00	09	See bitfield table.

5.16.1.1. DAC2 WCap

Bit	Bitfield Name	RW	Reset	Description
[31.:24]	Rsvd2	R	00	Reserved.
[23.:20]	Type	R	0	Widget type: 0h = Out Converter; 1h = In Converter; 2h = Summing (Mixer); 3h = Selector (Mux); 4h = Pin Complex; 5h = Power; 6h = Volume Knob; 7h = Beep Generator; 8h-Eh = Reserved; Fh = Vendor Defined
[19.:16]	Delay	R	D	Number of sample delays through widget.
[15.:12]	Rsvd1	R	0	Reserved.
[11]	SwapCap	R	1	Left/right swap support: 1 = yes 0 = no.
[10]	PwrCntrl	R	1	Power state support: 1 = yes 0 = no.
[9]	Dig	R	0	Digital stream support: 1 = yes (digital) 0 = no (analog).
[8]	ConnList	R	0	Connection list present: 1 = yes 0 = no.
[7]	UnSolCap	R	0	Unsolicited response support: 1 = yes 0 = no.

5.16.1.1. DAC2 WCap

Bit	Bitfield Name	RW	Reset	Description
[6]	ProcWidget	R	0	Processing state support: 1 = yes 0 = no.
[5]	Stripe	R	0	Striping support: 1 = yes 0 = no.
[4]	FormatOvrd	R	0	Stream format override: 1 = yes 0 = no.
[3]	AmpParOvrd	R	0	Amplifier capabilities override: 1 = yes no.
[2]	OutAmpPrsnt	R	1	Output amp present: 1 = yes 0 = no.
[1]	InAmpPrsnt	R	0	Input amp present: 1 = yes 0 = no.
[0]	Stereo	R	1	Stereo stream support: 1 = yes (stereo) 0 = no (mono).

5.16.2. DAC2 Cnvtr

	Verb ID	Payload	Response
Get	A00	00	See bitfield table.

5.16.2.1. DAC2 Cnvtr

Bit	Bitfield Name	RW	Reset	Description
[31..16]	Rsvd2	R	0000	Reserved.
[15]	StrmType	R	0	Stream type: 1 = Non-PCM 0 = PCM.
[14]	FrmtSmplRate	RW	0	Sample base rate: 1 = 44.1kHz 0 = 48kHz.
[13..11]	SmplRateMultp	RW	0	Sample base rate multiple: 000b= x1 (48kHz/44.1kHz or less); 001b= x2 (96kHz/88.2kHz/32kHz); 010b= x3 (144kHz); 011b= x4 (192kHz/176.4kHz); 100b-111b Reserved

5.16.2.1. DAC2 Cnvtr

Bit	Bitfield Name	RW	Reset	Description
[10.:8]	SmplRateDiv	RW	0	Sample base rate divider: 000b= Divide by 1 (48kHz/44.1kHz); 001b= Divide by 2 (24kHz/20.05kHz); 010b= Divide by 3 (16kHz/32kHz); 011b= Divide by 4 (11.025kHz); 100b= Divide by 5 (9.6kHz); 101b= Divide by 6 (8kHz); 110b= Divide by 7; 111b= Divide by 8 (6kHz)
[7]	Rsvd1	R	0	Reserved.
[6.:4]	BitsPerSmpl	RW	3	Bits per sample: 000b= 8 bits; 001b= 16 bits; 010b= 20 bits; 011b= 24 bits; 100b= 32 bits; 101b-111b= Reserved
[3.:0]	NmbrChan	RW	1	Total number of channels in the stream assigned to this converter: 0000b-1111b= 1-16 channels.

5.16.3. DAC2 OutAmpLeft

	Verb ID	Payload	Response
Get	BA0	00	See bitfield table.

5.16.3.1. DAC2 OutAmpLeft

Bit	Bitfield Name	RW	Reset	Description
[31.:8]	Rsvd	R	000000	Reserved.
[7]	Mute	RW	1	Amp mute: 1 = muted 0 = not muted.
[6.:0]	Gain	RW	7F	Amp gain step number (see OutAmp-Cap parameter pertaining to this widget).

5.16.4. DAC2 OutAmpRight

	Verb ID	Payload	Response
Get	B80	00	See bitfield table.

5.16.4.1. *DAC2 OutAmpRight*

Bit	Bitfield Name	RW	Reset	Description
[31.:8]	Rsvd	R	000000	Reserved.
[7]	Mute	RW	1	Amp mute: 1 = muted 0 = not muted.
[6.:0]	Gain	RW	7F	Amp gain step number (see OutAmp-Cap parameter pertaining to this widget).

5.16.5. *DAC2 PwrState*

	Verb ID	Payload	Response
Get	F05	00	See bitfield table.

5.16.5.1. *DAC2 PwrState*

Bit	Bitfield Name	RW	Reset	Description
[31.:6]	Rsvd2	R	0000000	Reserved.
[5.:4]	Act	R	3	Actual power state of this widget.
[3.:2]	Rsvd1	R	0	Reserved.
[1.:0]	Set	RW	3	Current power state setting for this widget.

5.16.6. *DAC2 CnvtrID*

	Verb ID	Payload	Response
Get	F06	00	See bitfield table.

5.16.6.1. DAC2 CnvtrID

Bit	Bitfield Name	RW	Reset	Description
[31.:8]	Rsvd	R	000000	Reserved.
[7.:4]	Strm	RW	0	Stream ID: 0h = Converter "off" 1h-Fh = valid IDs.
[3.:0]	Ch	RW	0	Channel assignment ("Ch" and "Ch+1" assigned as a pair for a stereo converter).

5.16.7. DAC2 LR

	Verb ID	Payload	Response
Get	F0C	00	See bitfield table.

5.16.7.1. DAC2 LR

Bit	Bitfield Name	RW	Reset	Description
[31.:3]	Rsvd2	R	00000000	Reserved.
[2]	SwapEn	RW	0	Swap enable: 1 = L/R swap enabled 0 = L/R swap disabled.
[1.:0]	Rsvd1	R	0	Reserved.

5.17. DAC3 Node (NID = 18)

5.17.1. DAC3 WCap

	Verb ID	Payload	Response
Get	F00	09	See bitfield table.

5.17.1.1. DAC3 WCap

Bit	Bitfield Name	RW	Reset	Description
[31.:24]	Rsvd2	R	00	Reserved.
[23.:20]	Type	R	0	Widget type: 0h = Out Converter; 1h = In Converter; 2h = Summing (Mixer); 3h = Selector (Mux); 4h = Pin Complex; 5h = Power; 6h = Volume Knob; 7h = Beep Generator; 8h-Eh = Reserved; Fh = Vendor Defined
[19.:16]	Delay	R	D	Number of sample delays through widget.
[15.:12]	Rsvd1	R	0	Reserved.
[11]	SwapCap	R	1	Left/right swap support: 1 = yes 0 = no.
[10]	PwrCntrl	R	1	Power state support: 1 = yes 0 = no.
[9]	Dig	R	0	Digital stream support: 1 = yes (digital) 0 = no (analog).
[8]	ConnList	R	0	Connection list present: 1 = yes 0 = no.
[7]	UnSolCap	R	0	Unsolicited response support: 1 = yes 0 = no.
[6]	ProcWidget	R	0	Processing state support: 1 = yes 0 = no.
[5]	Stripe	R	0	Striping support: 1 = yes 0 = no.
[4]	FormatOvrd	R	0	Stream format override: 1 = yes 0 = no.
[3]	AmpParOvrd	R	0	Amplifier capabilities override: 1 = yes no.
[2]	OutAmpPrsnt	R	1	Output amp present: 1 = yes 0 = no.
[1]	InAmpPrsnt	R	0	Input amp present: 1 = yes 0 = no.
[0]	Stereo	R	1	Stereo stream support: 1 = yes (stereo) 0 = no (mono).

5.17.2. DAC3 Cnvtr

	Verb ID	Payload	Response
Get	A00	00	See bitfield table.

5.17.2.1. DAC3 Cnvtr

Bit	Bitfield Name	RW	Reset	Description
[31..16]	Rsvd2	R	0000	Reserved.
[15]	StrmType	R	0	Stream type: 1 = Non-PCM 0 = PCM.
[14]	FrmtSmplRate	RW	0	Sample base rate: 1 = 44.1kHz 0 = 48kHz.
[13..11]	SmplRateMultp	RW	0	Sample base rate multiple: 000b= x1 (48kHz/44.1kHz or less); 001b= x2 (96kHz/88.2kHz/32kHz); 010b= x3 (144kHz); 011b= x4 (192kHz/176.4kHz); 100b-111b Reserved
[10..8]	SmplRateDiv	RW	0	Sample base rate divider: 000b= Divide by 1 (48kHz/44.1kHz); 001b= Divide by 2 (24kHz/20.05kHz); 010b= Divide by 3 (16kHz/32kHz); 011b= Divide by 4 (11.025kHz); 100b= Divide by 5 (9.6kHz); 101b= Divide by 6 (8kHz); 110b= Divide by 7; 111b= Divide by 8 (6kHz)
[7]	Rsvd1	R	0	Reserved.
[6..4]	BitsPerSmpl	RW	3	Bits per sample: 000b= 8 bits; 001b= 16 bits; 010b= 20 bits; 011b= 24 bits; 100b= 32 bits; 101b-111b= Reserved
[3..0]	NmbrChan	RW	1	Total number of channels in the stream assigned to this converter: 0000b-1111b= 1-16 channels.

5.17.3. DAC3 OutAmpLeft

	Verb ID	Payload	Response
Get	BA0	00	See bitfield table.

5.17.3.1. *DAC3 OutAmpLeft*

Bit	Bitfield Name	RW	Reset	Description
[31.:8]	Rsvd	R	000000	Reserved.
[7]	Mute	RW	1	Amp mute: 1 = muted 0 = not muted.
[6.:0]	Gain	RW	7F	Amp gain step number (see OutAmp-Cap parameter pertaining to this widget).

5.17.4. *DAC3 OutAmpRight*

	Verb ID	Payload	Response
Get	B80	00	See bitfield table.

5.17.4.1. *DAC3 OutAmpRight*

Bit	Bitfield Name	RW	Reset	Description
[31.:8]	Rsvd	R	000000	Reserved.
[7]	Mute	RW	1	Amp mute: 1 = muted 0 = not muted.
[6.:0]	Gain	RW	7F	Amp gain step number (see OutAmp-Cap parameter pertaining to this widget).

5.17.5. *DAC3 PwrState*

	Verb ID	Payload	Response
Get	F05	00	See bitfield table.

5.17.5.1. DAC3 PwrState

Bit	Bitfield Name	RW	Reset	Description
[31.:6]	Rsvd2	R	0000000	Reserved.
[5.:4]	Act	R	3	Actual power state of this widget.
[3.:2]	Rsvd1	R	0	Reserved.
[1.:0]	Set	RW	3	Current power state setting for this widget.

5.17.6. DAC3 CnvtrID

	Verb ID	Payload	Response
Get	F06	00	See bitfield table.

5.17.6.1. DAC3 CnvtrID

Bit	Bitfield Name	RW	Reset	Description
[31.:8]	Rsvd	R	000000	Reserved.
[7.:4]	Strm	RW	0	Stream ID: 0h = Converter "off" 1h-Fh = valid IDs.
[3.:0]	Ch	RW	0	Channel assignment ("Ch" and "Ch+1" assigned as a pair for a stereo converter).

5.17.7. DAC3 LR

	Verb ID	Payload	Response
Get	F0C	00	See bitfield table.

5.17.7.1. DAC3 LR

Bit	Bitfield Name	RW	Reset	Description
[31.:3]	Rsvd2	R	00000000	Reserved.
[2]	SwapEn	RW	0	Swap enable: 1 = L/R swap enabled 0 = L/R swap disabled.
[1.:0]	Rsvd1	R	0	Reserved.

5.18. DAC4 Node (NID = 19)

5.18.1. DAC4 WCap

	Verb ID	Payload	Response
Get	F00	09	See bitfield table.

5.18.1.1. DAC4 WCap

Bit	Bitfield Name	RW	Reset	Description
[31.:24]	Rsvd2	R	00	Reserved.
[23.:20]	Type	R	0	Widget type: 0h = Out Converter; 1h = In Converter; 2h = Summing (Mixer); 3h = Selector (Mux); 4h = Pin Complex; 5h = Power; 6h = Volume Knob; 7h = Beep Generator; 8h-Eh = Reserved; Fh = Vendor Defined
[19.:16]	Delay	R	D	Number of sample delays through widget.
[15.:12]	Rsvd1	R	0	Reserved.
[11]	SwapCap	R	1	Left/right swap support: 1 = yes 0 = no.
[10]	PwrCntrl	R	1	Power state support: 1 = yes 0 = no.
[9]	Dig	R	0	Digital stream support: 1 = yes (digital) 0 = no (analog).
[8]	ConnList	R	0	Connection list present: 1 = yes 0 = no.
[7]	UnSolCap	R	0	Unsolicited response support: 1 = yes 0 = no.

5.18.1.1. DAC4 WCap

Bit	Bitfield Name	RW	Reset	Description
[6]	ProcWidget	R	0	Processing state support: 1 = yes 0 = no.
[5]	Stripe	R	0	Striping support: 1 = yes 0 = no.
[4]	FormatOvrd	R	0	Stream format override: 1 = yes 0 = no.
[3]	AmpParOvrd	R	0	Amplifier capabilities override: 1 = yes no.
[2]	OutAmpPrsnt	R	1	Output amp present: 1 = yes 0 = no.
[1]	InAmpPrsnt	R	0	Input amp present: 1 = yes 0 = no.
[0]	Stereo	R	1	Stereo stream support: 1 = yes (stereo) 0 = no (mono).

5.18.2. DAC4 Cnvtr

	Verb ID	Payload	Response
Get	A00	00	See bitfield table.

5.18.2.1. DAC4 Cnvtr

Bit	Bitfield Name	RW	Reset	Description
[31..16]	Rsvd2	R	0000	Reserved.
[15]	StrmType	R	0	Stream type: 1 = Non-PCM 0 = PCM.
[14]	FrmtSmpIRate	RW	0	Sample base rate: 1 = 44.1kHz 0 = 48kHz.
[13..11]	SmpIRateMultp	RW	0	Sample base rate multiple: 000b= x1 (48kHz/44.1kHz or less); 001b= x2 (96kHz/88.2kHz/32kHz); 010b= x3 (144kHz); 011b= x4 (192kHz/176.4kHz); 100b-111b Reserved

5.18.2.1. DAC4 Cnvtr

Bit	Bitfield Name	RW	Reset	Description
[10.:8]	SmplRateDiv	RW	0	Sample base rate divider: 000b= Divide by 1 (48kHz/44.1kHz); 001b= Divide by 2 (24kHz/20.05kHz); 010b= Divide by 3 (16kHz/32kHz); 011b= Divide by 4 (11.025kHz); 100b= Divide by 5 (9.6kHz); 101b= Divide by 6 (8kHz); 110b= Divide by 7; 111b= Divide by 8 (6kHz)
[7]	Rsvd1	R	0	Reserved.
[6.:4]	BitsPerSmpl	RW	3	Bits per sample: 000b= 8 bits; 001b= 16 bits; 010b= 20 bits; 011b= 24 bits; 100b= 32 bits; 101b-111b= Reserved
[3.:0]	NmbrChan	RW	1	Total number of channels in the stream assigned to this converter: 0000b-1111b= 1-16 channels.

5.18.3. DAC4 OutAmpLeft

	Verb ID	Payload	Response
Get	BA0	00	See bitfield table.

5.18.3.1. DAC4 OutAmpLeft

Bit	Bitfield Name	RW	Reset	Description
[31.:8]	Rsvd	R	000000	Reserved.
[7]	Mute	RW	1	Amp mute: 1 = muted 0 = not muted.
[6.:0]	Gain	RW	7F	Amp gain step number (see OutAmp-Cap parameter pertaining to this widget).

5.18.4. DAC4 OutAmpRight

	Verb ID	Payload	Response
Get	B80	00	See bitfield table.

5.18.4.1. DAC4 OutAmpRight

Bit	Bitfield Name	RW	Reset	Description
[31.:8]	Rsvd	R	000000	Reserved.
[7]	Mute	RW	1	Amp mute: 1 = muted 0 = not muted.
[6.:0]	Gain	RW	7F	Amp gain step number (see OutAmp-Cap parameter pertaining to this widget).

5.18.5. DAC4 PwrState

	Verb ID	Payload	Response
Get	F05	00	See bitfield table.

5.18.5.1. DAC1 PwrState

Bit	Bitfield Name	RW	Reset	Description
[31.:6]	Rsvd2	R	0000000	Reserved.
[5.:4]	Act	R	3	Actual power state of this widget.
[3.:2]	Rsvd1	R	0	Reserved.
[1.:0]	Set	RW	3	Current power state setting for this widget.

5.18.6. DAC4 CnvtrID

	Verb ID	Payload	Response
Get	F06	00	See bitfield table.

5.18.6.1. DAC4 CnvtrID

Bit	Bitfield Name	RW	Reset	Description
[31.:8]	Rsvd	R	000000	Reserved.
[7.:4]	Strm	RW	0	Stream ID: 0h = Converter "off" 1h-Fh = valid IDs.
[3.:0]	Ch	RW	0	Channel assignment ("Ch" and "Ch+1" assigned as a pair for a stereo converter).

5.18.7. DAC4 LR

	Verb ID	Payload	Response
Get	F0C	00	See bitfield table.

5.18.7.1. DAC4 LR

Bit	Bitfield Name	RW	Reset	Description
[31.:3]	Rsvd2	R	00000000	Reserved.
[2]	SwapEn	RW	0	Swap enable: 1 = L/R swap enabled 0 = L/R swap disabled.
[1.:0]	Rsvd1	R	0	Reserved.

5.19. ADC0 Node (NID = 1A)

5.19.1. ADC0 WCap

	Verb ID	Payload	Response
Get	F00	09	See bitfield table.

5.19.1.1. ADC0 WCap

Bit	Bitfield Name	RW	Reset	Description
[31.:24]	Rsvd2	R	00	Reserved.
[23.:20]	Type	R	1	Widget type: 0h = Out Converter; 1h = In Converter; 2h = Summing (Mixer); 3h = Selector (Mux); 4h = Pin Complex; 5h = Power; 6h = Volume Knob; 7h = Beep Generator; 8h-Eh = Reserved; Fh = Vendor Defined
[19.:16]	Delay	R	D	Number of sample delays through widget.
[15.:12]	Rsvd1	R	0	Reserved.
[11]	SwapCap	R	0	Left/right swap support: 1 = yes 0 = no.
[10]	PwrCntrl	R	1	Power state support: 1 = yes 0 = no.
[9]	Dig	R	0	Digital stream support: 1 = yes (digital) 0 = no (analog).
[8]	ConnList	R	1	Connection list present: 1 = yes 0 = no.
[7]	UnSolCap	R	0	Unsolicited response support: 1 = yes 0 = no.
[6]	ProcWidget	R	1	Processing state support: 1 = yes 0 = no.
[5]	Stripe	R	0	Striping support: 1 = yes 0 = no.
[4]	FormatOvrd	R	0	Stream format override: 1 = yes 0 = no.
[3]	AmpParOvrd	R	0	Amplifier capabilities override: 1 = yes no.
[2]	OutAmpPrsnt	R	0	Output amp present: 1 = yes 0 = no.
[1]	InAmpPrsnt	R	0	Input amp present: 1 = yes 0 = no.
[0]	Stereo	R	1	Stereo stream support: 1 = yes (stereo) 0 = no (mono).

5.19.2. ADC0 ConLst

	Verb ID	Payload	Response
Get	F00	0E	See bitfield table.

5.19.2.1. ADC0 ConLst

Bit	Bitfield Name	RW	Reset	Description
[31..8]	Rsvd	R	000000	Reserved.
[7]	LForm	R	0	Connection list format: 1 = long-form (15-bit) NID entries 0 = short-form (7-bit) NID entries.
[6..0]	ConL	R	01	Number of NID entries in connection list.

5.19.3. ADC0 ConLstEntry0

	Verb ID	Payload	Response
Get	F02	00	See bitfield table.

5.19.3.1. ADC0 ConLstEntry0

Bit	Bitfield Name	RW	Reset	Description
[31..24]	ConL3	R	00	Unused list entry.
[23..16]	ConL2	R	00	Unused list entry.
[15..8]	ConL1	R	00	Unused list entry.
[7..0]	ConL0	R	20	ADC0Mux Selector widget (0x20)

5.19.4. ADC0 Cnvtr

	Verb ID	Payload	Response
Get	A	0000	See bitfield table.

5.19.4.1. ADC0 Cnvtr

Bit	Bitfield Name	RW	Reset	Description
[31.:16]	Rsvd2	R	0000	Reserved.
[15]	StrmType	R	0	Stream type: 1 = Non-PCM 0 = PCM.
[14]	FrmtSmplRate	RW	0	Sample base rate: 1 = 44.1kHz 0 = 48kHz.
[13.:11]	SmplRateMultp	RW	0	Sample base rate multiple: 000b= x1 (48kHz/44.1kHz or less); 001b= x2 (96kHz/88.2kHz/32kHz); 010b= x3 (144kHz); 011b= x4 (192kHz/176.4kHz); 100b-111b Reserved
[10.:8]	SmplRateDiv	RW	0	Sample base rate divider: 000b= Divide by 1 (48kHz/44.1kHz); 001b= Divide by 2 (24kHz/20.05kHz); 010b= Divide by 3 (16kHz/32kHz); 011b= Divide by 4 (11.025kHz); 100b= Divide by 5 (9.6kHz); 101b= Divide by 6 (8kHz); 110b= Divide by 7; 111b= Divide by 8 (6kHz)
[7]	Rsvd1	R	0	Reserved.
[6.:4]	BitsPerSmpl	RW	3	Bits per sample: 000b= 8 bits; 001b= 16 bits; 010b= 20 bits; 011b= 24 bits; 100b= 32 bits; 101b-111b= Reserved
[3.:0]	NmbrChan	RW	1	Total number of channels in the stream assigned to this converter: 0000b-1111b= 1-16 channels.

5.19.5. ADC0 ProcState

	Verb ID	Payload	Response
Get	F03	00	See bitfield table.

5.19.5.1. *ADC0 ProcState*

Bit	Bitfield Name	RW	Reset	Description
[31.:8]	Rsvd2	R	000000	Reserved.
[7]	HPFOCDIS	RW	0	HPF offset calculation disable. 1 = calculation disabled; 0 = calculation enabled.
[6.:2]	Rsvd1	R	00	Reserved.
[1.:0]	ADCHPFByP	RW	1	Processing State: 00b= bypass the ADC HPF ("off") 01b-11b= ADC HPF is enabled ("on" or "benign").

5.19.6. *ADC0 PwrState*

	Verb ID	Payload	Response
Get	F05	00	See bitfield table.

5.19.6.1. *ADC0 PwrState*

Bit	Bitfield Name	RW	Reset	Description
[31.:6]	Rsvd2	R	0000000	Reserved.
[5.:4]	Act	R	3	Actual power state of this widget.
[3.:2]	Rsvd1	R	0	Reserved.
[1.:0]	Set	RW	3	Current power state setting for this widget.

5.19.7. *ADC0 CnvtrID*

	Verb ID	Payload	Response
Get	F06	00	See bitfield table.

5.19.7.1. ADC0 CnvtrID

Bit	Bitfield Name	RW	Reset	Description
[31.:8]	Rsvd	R	000000	Reserved.
[7.:4]	Strm	RW	0	Stream ID: 0h = Converter "off" 1h-Fh = valid IDs.
[3.:0]	Ch	RW	0	Channel assignment ("Ch" and "Ch+1" assigned as a pair for a stereo converter).

5.20. ADC1 Node (NID = 1B)

5.20.1. ADC1 WCap

	Verb ID	Payload	Response
Get	F00	09	See bitfield table.

5.20.1.1. ADC1 WCap

Bit	Bitfield Name	RW	Reset	Description
[31.:24]	Rsvd2	R	00	Reserved.
[23.:20]	Type	R	1	Widget type: 0h = Out Converter; 1h = In Converter; 2h = Summing (Mixer); 3h = Selector (Mux); 4h = Pin Complex; 5h = Power; 6h = Volume Knob; 7h = Beep Generator; 8h-Eh = Reserved; Fh = Vendor Defined
[19.:16]	Delay	R	D	Number of sample delays through widget.
[15.:12]	Rsvd1	R	0	Reserved.
[11]	SwapCap	R	0	Left/right swap support: 1 = yes 0 = no.
[10]	PwrCntrl	R	1	Power state support: 1 = yes 0 = no.
[9]	Dig	R	0	Digital stream support: 1 = yes (digital) 0 = no (analog).
[8]	ConnList	R	1	Connection list present: 1 = yes 0 = no.

5.20.1.1. *ADC1 WCap*

Bit	Bitfield Name	RW	Reset	Description
[7]	UnSolCap	R	0	Unsolicited response support: 1 = yes 0 = no.
[6]	ProcWidget	R	1	Processing state support: 1 = yes 0 = no.
[5]	Stripe	R	0	Striping support: 1 = yes 0 = no.
[4]	FormatOvrd	R	0	Stream format override: 1 = yes 0 = no.
[3]	AmpParOvrd	R	0	Amplifier capabilities override: 1 = yes no.
[2]	OutAmpPrsnt	R	0	Output amp present: 1 = yes 0 = no.
[1]	InAmpPrsnt	R	0	Input amp present: 1 = yes 0 = no.
[0]	Stereo	R	1	Stereo stream support: 1 = yes (stereo) 0 = no (mono).

5.20.2. *ADC1 ConLst*

	Verb ID	Payload	Response
Get	F00	0E	See bitfield table.

5.20.2.1. *ADC1 ConLst*

Bit	Bitfield Name	RW	Reset	Description
[31..8]	Rsvd	R	000000	Reserved.
[7]	LForm	R	0	Connection list format: 1 = long-form (15-bit) NID entries 0 = short-form (7-bit) NID entries.
[6..0]	ConL	R	01	Number of NID entries in connection list.

5.20.3. *ADC1 ConLstEntry0*

	Verb ID	Payload	Response
Get	F02	00	See bitfield table.

5.20.3.1. ADC1 ConLstEntry0

Bit	Bitfield Name	RW	Reset	Description
[31.:24]	ConL3	R	00	Unused list entry.
[23.:16]	ConL2	R	00	Unused list entry.
[15.:8]	ConL1	R	00	Unused list entry.
[7.:0]	ConL0	R	21	ADC1Mux widget (0x21)

5.20.4. ADC1 Cnvtr

	Verb ID	Payload	Response
Get	A00	00	See bitfield table.

5.20.4.1. ADC1 Cnvtr

Bit	Bitfield Name	RW	Reset	Description
[31.:16]	Rsvd2	R	0000	Reserved.
[15]	StrmType	R	0	Stream type: 1 = Non-PCM 0 = PCM.
[14]	FrmtSmplRate	RW	0	Sample base rate: 1 = 44.1kHz 0 = 48kHz.
[13.:11]	SmplRateMultp	RW	0	Sample base rate multiple: 000b= x1 (48kHz/44.1kHz or less); 001b= x2 (96kHz/88.2kHz/32kHz); 010b= x3 (144kHz); 011b= x4 (192kHz/176.4kHz); 100b-111b Reserved
[10.:8]	SmplRateDiv	RW	0	Sample base rate divider: 000b= Divide by 1 (48kHz/44.1kHz); 001b= Divide by 2 (24kHz/20.05kHz); 010b= Divide by 3 (16kHz/32kHz); 011b= Divide by 4 (11.025kHz); 100b= Divide by 5 (9.6kHz); 101b= Divide by 6 (8kHz); 110b= Divide by 7; 111b= Divide by 8 (6kHz)
[7]	Rsvd1	R	0	Reserved.

5.20.4.1. *ADC1 Cnvtr*

Bit	Bitfield Name	RW	Reset	Description
[6.:4]	BitsPerSmpl	RW	3	Bits per sample: 000b= 8 bits; 001b= 16 bits; 010b= 20 bits; 011b= 24 bits; 100b= 32 bits; 101b-111b= Reserved
[3.:0]	NmbrChan	RW	1	Total number of channels in the stream assigned to this converter: 0000b-1111b= 1-16 channels.

5.20.5. *ADC1 ProcState*

	Verb ID	Payload	Response
Get	F03	00	See bitfield table.

5.20.5.1. *ADC1 ProcState*

Bit	Bitfield Name	RW	Reset	Description
[31.:8]	Rsvd2	R	000000	Reserved.
[7]	HPFOCDIS	RW	0	HPF offset calculation disable. 1 = calculation disabled; 0 = calculation enabled.
[6.:2]	Rsvd1	R	00	Reserved.
[1.:0]	ADCHPFByp	RW	1	Processing State: 00b= bypass the ADC HPF ("off") 01b-11b= ADC HPF is enabled ("on" or "benign").

5.20.6. *ADC1 PwrState*

	Verb ID	Payload	Response
Get	F05	00	See bitfield table.

5.20.6.1. *ADC1 PwrState*

Bit	Bitfield Name	RW	Reset	Description
[31.:6]	Rsvd2	R	0000000	Reserved.
[5.:4]	Act	R	3	Actual power state of this widget.
[3.:2]	Rsvd1	R	0	Reserved.
[1.:0]	Set	RW	3	Current power state setting for this widget.

5.20.7. *ADC1 CnvtrID*

	Verb ID	Payload	Response
Get	F06	00	See bitfield table.

5.20.7.1. *ADC1 CnvtrID*

Bit	Bitfield Name	RW	Reset	Description
[31.:8]	Rsvd	R	000000	Reserved.
[7.:4]	Strm	RW	0	Stream ID: 0h = Converter "off" 1h-Fh = valid IDs.
[3.:0]	Ch	RW	0	Channel assignment ("Ch" and "Ch+1" assigned as a pair for a stereo converter).

5.21. DigBeep Node (NID = 1C)

5.21.1. *DigBeep WCap*

	Verb ID	Payload	Response
Get	F00	09	See bitfield table.

5.21.1.1. *DigBeep WCap*

Bit	Bitfield Name	RW	Reset	Description
[31.:24]	Rsvd3	R	00	Reserved.
[23.:20]	Type	R	7	Widget type: 0h = Out Converter; 1h = In Converter; 2h = Summing (Mixer); 3h = Selector (Mux); 4h = Pin Complex; 5h = Power; 6h = Volume Knob; 7h = Beep Generator; 8h-Eh = Reserved; Fh = Vendor Defined
[19.:4]	Rsvd2	R	0	Reserved.
[3]	AmpParOvrd	R	1	Amplifier capabilities override: 1 = yes, no.
[2]	OutAmpPrsnt	R	1	Output amp present: 1 = yes, 0 = no.
[1.:0]	Rsvd1	R	0	Reserved.

5.21.2. *DigBeep OutAmpCap*

	Verb ID	Payload	Response
Get	F00	12	See bitfield table.

5.21.2.1. *DigBeep OutAmpCap*

Bit	Bitfield Name	RW	Reset	Description
[31]	Mute	R	1	Mute support: 1 = yes, 0 = no.
[30.:23]	Rsvd3	R	00	Reserved.
[22.:16]	StepSize	R	17	Size of each step in the gain range: 0 to 127 = .25dB to 32dB, in .25dB steps.
[15]	Rsvd2	R	0	Reserved.
[14.:8]	NumSteps	R	03	Number of gains steps (number of possible settings - 1).
[7]	Rsvd1	R	0	Reserved.
[6.:0]	Offset	R	03	Indicates which step is 0dB

5.21.3. DigBeep OutAmpLeft

	Verb ID	Payload	Response
Get	BA0	00	See bitfield table.

5.21.3.1. DigBeep OutAmpLeft

Bit	Bitfield Name	RW	Reset	Description
[31..8]	Rsvd2	R	000000	Reserved.
[7]	Mute	RW	0	Amp mute: 1 = muted, 0 = not muted.
[6..2]	Rsvd1	R	00	Reserved.
[1..0]	Gain	RW	0	Amp gain step number (see OutAmp-Cap parameter pertaining to this widget).

5.21.4. DigBeep Gen

	Verb ID	Payload	Response
Get	F0A	00	See bitfield table.

5.21.4.1. *DigBeep Gen*

Bit	Bitfield Name	RW	Reset	Description
[31.:8]	Rsvd	R	000000	Reserved.
[7.:0]	Divider	RW	00	Enable internal PC-Beep generation. Divider == 00h disables internal PC Beep generation and enables normal operation of the codec. Divider != 00h generates the beep tone on all Pin Complexes that are currently configured as outputs. The HD Audio spec states that the beep tone frequency = (48kHz HD Audio SYNC rate) / (4*Divider), producing tones from 47 Hz to 12 kHz (logarithmic scale). This part can selectively generate tones with frequency = 48KHz * (257 - Divider) / 1024, yielding a linear range from 12kHz to 93.75Hz in steps of 46.875Hz. If the FreqShift bit is set, then the beep tones generated have frequency = 48KHz * (513 - Divider) / 1024, yielding a range of 24kHz to 12093.75Hz in steps of 46.875Hz.

5.22. Mixer Node (NID = 1D)

5.22.1. *Mixer WCap*

	Verb ID	Payload	Response
Get	F00	09	See bitfield table.

5.22.1.1. *MonoMixer WCap*

Bit	Bitfield Name	RW	Reset	Description
[31.:24]	Rsvd2	R	00	Reserved.
[23.:20]	Type	R	2	Widget type: 0h = Out Converter; 1h = In Converter; 2h = Summing (Mixer); 3h = Selector (Mux); 4h = Pin Complex; 5h = Power; 6h = Volume Knob; 7h = Beep Generator; 8h-Eh = Reserved; Fh = Vendor Defined

5.22.1.1. *MonoMixer WCap*

Bit	Bitfield Name	RW	Reset	Description
[19.:16]	Delay	R	0	Number of sample delays through widget.
[15.:12]	Rsvd1	R	0	Reserved.
[11]	SwapCap	R	0	Left/right swap support: 1 = yes 0 = no.
[10]	PwrCntrl	R	0	Power state support: 1 = yes 0 = no.
[9]	Dig	R	0	Digital stream support: 1 = yes (digital) 0 = no (analog).
[8]	ConnList	R	1	Connection list present: 1 = yes 0 = no.
[7]	UnSolCap	R	0	Unsolicited response support: 1 = yes 0 = no.
[6]	ProcWidget	R	0	Processing state support: 1 = yes 0 = no.
[5]	Stripe	R	0	Striping support: 1 = yes 0 = no.
[4]	FormatOvrd	R	0	Stream format override: 1 = yes 0 = no.
[3]	AmpParOvrd	R	1	Amplifier capabilities override: 1 = yes no.
[2]	OutAmpPrsnt	R	0	Output amp present: 1 = yes 0 = no.
[1]	InAmpPrsnt	R	1	Input amp present: 1 = yes 0 = no.
[0]	Stereo	R	1	Stereo stream support: 1 = yes (stereo) 0 = no (mono).

5.22.2. *Mixer ConLst*

	Verb ID	Payload	Response
Get	F00	0E	See bitfield table.

5.22.2.1. *Mixer ConLst*

Bit	Bitfield Name	RW	Reset	Description
[31.:8]	Rsvd	R	000000	Reserved.
[7]	LForm	R	0	Connection list format: 1 = long-form (15-bit) NID entries 0 = short-form (7-bit) NID entries.
[6.:0]	ConL	R	03	Number of NID entries in connection list.

5.22.3. *Mixer ConLstEntry0*

	Verb ID	Payload	Response
Get	F02	00	See bitfield table.

5.22.3.1. *Mixer ConLstEntry0*

Bit	Bitfield Name	RW	Reset	Description
[31.:24]	ConL3	R	00	Unused list entry.
[23.:16]	ConL2	R	12	Port I Pin Widget (CD In) (0x12),. Uses InAmpLeft5/InAmpRight5 controls
[15]	ConL1Range	R	2B	1 = ConL0..ConL1 defines a range of selectable inputs.
[14.:8]	ConL1	R	2B	InPort3Mux Selector widget (0x2B). Uses InAmpLeft3/InAmpRight3 controls.
[7.:0]	ConL0	R	28	InPort0Mux Selector widget (0x28). Uses InAmpLeft0/InAmpRight0 controls.

5.22.4. *Mixer InAmpCap*

	Verb ID	Payload	Response
Get	F00	0D	See bitfield table.

5.22.4.1. *Mixer InAmpCap*

Bit	Bitfield Name	RW	Reset	Description
[31]	Mute	R	1	Mute support: 1 = yes 0 = no.
[30..23]	Rsvd3	R	00	Reserved.
[22..16]	StepSize	R	05	Size of each step in the gain range: 0 to 127 = .25dB to 32dB in .25dB steps.
[15]	Rsvd2	R	0	Reserved.
[14..8]	NumSteps	R	1F	Number of gains steps (number of possible settings - 1).
[7]	Rsvd1	R	0	Reserved.
[6..0]	Offset	R	17	Indicates which step is 0dB

5.22.5. *Mixer InAmpLeft0*

	Verb ID	Payload	Response
Get	B20	00	See bitfield table.

5.22.5.1. *Mixer InAmpLeft0*

Bit	Bitfield Name	RW	Reset	Description
[31..8]	Rsvd2	R	000000	Reserved.
[7]	Mute	RW	1	Amp mute: 1 = muted 0 = not muted.
[6..5]	Rsvd1	R	0	Reserved.
[4..0]	Gain	RW	17	Amp gain step number (see InAmpCap parameter pertaining to this widget).

5.22.6. *Mixer InAmpRight0*

	Verb ID	Payload	Response
Get	B00	00	See bitfield table.

5.22.6.1. *Mixer InAmpRight0*

Bit	Bitfield Name	RW	Reset	Description
[31.:8]	Rsvd2	R	000000	Reserved.
[7]	Mute	RW	1	Amp mute: 1 = muted 0 = not muted.
[6.:5]	Rsvd1	R	0	Reserved.
[4.:0]	Gain	RW	17	Amp gain step number (see InAmpCap parameter pertaining to this widget).

5.22.7. *Mixer InAmpLeft1*

	Verb ID	Payload	Response
Get	B20	01	See bitfield table.

5.22.7.1. *Mixer InAmpLeft1*

Bit	Bitfield Name	RW	Reset	Description
[31.:8]	Rsvd2	R	000000	Reserved.
[7]	Mute	RW	1	Amp mute: 1 = muted 0 = not muted.
[6.:5]	Rsvd1	R	0	Reserved.
[4.:0]	Gain	RW	17	Amp gain step number (see InAmpCap parameter pertaining to this widget).

5.22.8. *Mixer InAmpRight1*

	Verb ID	Payload	Response
Get	B00	01	See bitfield table.

5.22.8.1. *Mixer InAmpRight1*

Bit	Bitfield Name	RW	Reset	Description
[31.:8]	Rsvd2	R	000000	Reserved.
[7]	Mute	RW	1	Amp mute: 1 = muted 0 = not muted.
[6.:5]	Rsvd1	R	0	Reserved.
[4.:0]	Gain	RW	17	Amp gain step number (see InAmpCap parameter pertaining to this widget).

5.22.9. *Mixer InAmpLeft2*

	Verb ID	Payload	Response
Get	B20	02	See bitfield table.

5.22.9.1. *Mixer InAmpLeft2*

Bit	Bitfield Name	RW	Reset	Description
[31.:8]	Rsvd2	R	000000	Reserved.
[7]	Mute	RW	1	Amp mute: 1 = muted 0 = not muted.
[6.:5]	Rsvd1	R	0	Reserved.
[4.:0]	Gain	RW	17	Amp gain step number (see InAmpCap parameter pertaining to this widget).

5.22.10. *Mixer InAmpRight2*

	Verb ID	Payload	Response
Get	B00	02	See bitfield table.

5.22.10.1. Mixer InAmpRight0

Bit	Bitfield Name	RW	Reset	Description
[31.:8]	Rsvd2	R	000000	Reserved.
[7]	Mute	RW	1	Amp mute: 1 = muted 0 = not muted.
[6.:5]	Rsvd1	R	0	Reserved.
[4.:0]	Gain	RW	17	Amp gain step number (see InAmpCap parameter pertaining to this widget).

5.22.11. Mixer InAmpLeft3

	Verb ID	Payload	Response
Get	B20	03	See bitfield table.

5.22.11.1. Mixer InAmpLeft3

Bit	Bitfield Name	RW	Reset	Description
[31.:8]	Rsvd2	R	000000	Reserved.
[7]	Mute	RW	1	Amp mute: 1 = muted 0 = not muted.
[6.:5]	Rsvd1	R	0	Reserved.
[4.:0]	Gain	RW	17	Amp gain step number (see InAmpCap parameter pertaining to this widget).

5.22.12. Mixer InAmpRight3

	Verb ID	Payload	Response
Get	B00	03	See bitfield table.

5.22.12.1. Mixer InAmpRight3

Bit	Bitfield Name	RW	Reset	Description
[31.:8]	Rsvd2	R	000000	Reserved.
[7]	Mute	RW	1	Amp mute: 1 = muted 0 = not muted.
[6.:5]	Rsvd1	R	0	Reserved.
[4.:0]	Gain	RW	17	Amp gain step number (see InAmpCap parameter pertaining to this widget).

5.22.13. Mixer InAmpLeft4

	Verb ID	Payload	Response
Get	B20	04	See bitfield table.

5.22.13.1. Mixer InAmpLeft4

Bit	Bitfield Name	RW	Reset	Description
[31.:8]	Rsvd2	R	000000	Reserved.
[7]	Mute	RW	1	Amp mute: 1 = muted 0 = not muted.
[6.:5]	Rsvd1	R	0	Reserved.
[4.:0]	Gain	RW	17	Amp gain step number (see InAmpCap parameter pertaining to this widget).

5.22.14. Mixer InAmpRight4

	Verb ID	Payload	Response
Get	B00	04	See bitfield table.

5.22.14.1. Mixer InAmpRight0

Bit	Bitfield Name	RW	Reset	Description
[31.:8]	Rsvd2	R	000000	Reserved.
[7]	Mute	RW	1	Amp mute: 1 = muted 0 = not muted.
[6.:5]	Rsvd1	R	0	Reserved.
[4.:0]	Gain	RW	17	Amp gain step number (see InAmpCap parameter pertaining to this widget).

5.23. MixerOutVol Node (NID = 1E)

5.23.1. MixerOutVol WCap

	Verb ID	Payload	Response
Get	F00	09	See bitfield table.

5.23.1.1. MonoMixer WCap

Bit	Bitfield Name	RW	Reset	Description
[31.:24]	Rsvd2	R	00	Reserved.
[23.:20]	Type	R	3	Widget type: 0h = Out Converter; 1h = In Converter; 2h = Summing (Mixer); 3h = Selector (Mux); 4h = Pin Complex; 5h = Power; 6h = Volume Knob; 7h = Beep Generator; 8h-Eh = Reserved; Fh = Vendor Defined
[19.:16]	Delay	R	0	Number of sample delays through widget.
[15.:12]	Rsvd1	R	0	Reserved.
[11]	SwapCap	R	0	Left/right swap support: 1 = yes 0 = no.
[10]	PwrCntrl	R	0	Power state support: 1 = yes 0 = no.
[9]	Dig	R	0	Digital stream support: 1 = yes (digital) 0 = no (analog).
[8]	ConnList	R	1	Connection list present: 1 = yes 0 = no.

5.23.1.1. *MonoMixer WCap*

Bit	Bitfield Name	RW	Reset	Description
[7]	UnSolCap	R	0	Unsolicited response support: 1 = yes 0 = no.
[6]	ProcWidget	R	0	Processing state support: 1 = yes 0 = no.
[5]	Stripe	R	0	Striping support: 1 = yes 0 = no.
[4]	FormatOvrd	R	0	Stream format override: 1 = yes 0 = no.
[3]	AmpParOvrd	R	1	Amplifier capabilities override: 1 = yes no.
[2]	OutAmpPrsnt	R	1	Output amp present: 1 = yes 0 = no.
[1]	InAmpPrsnt	R	1	Input amp present: 1 = yes 0 = no.
[0]	Stereo	R	1	Stereo stream support: 1 = yes (stereo) 0 = no (mono).

5.23.2. *MixerOutVol ConLst*

	Verb ID	Payload	Response
Get	F00	0E	See bitfield table.

5.23.2.1. *MixerOutVol ConLst*

Bit	Bitfield Name	RW	Reset	Description
[31..8]	Rsvd	R	000000	Reserved.
[7]	LForm	R	0	Connection list format: 1 = long-form (15-bit) NID entries 0 = short-form (7-bit) NID entries.
[6..0]	ConL	R	1	Number of NID entries in connection list.

5.23.3. *MixerOutVol ConLstEntry0*

	Verb ID	Payload	Response
Get	F02	00	See bitfield table.

5.23.3.1. *Mixer ConLstEntry0*

Bit	Bitfield Name	RW	Reset	Description
[31.:24]	ConL3	R	00	Unused list entry.
[23.:16]	ConL2	R	00	Unused list entry.
[15.:8]	ConL1	R	00	Unused list entry.
[7.:0]	ConL0	R	1D	Mixer Summing widget (0x1D)

5.23.4. *MixerOutVol OutAmpCap*

	Verb ID	Payload	Response
Get	F00	12	See bitfield table.

5.23.4.1. *MixerOutVol OutAmpCap*

Bit	Bitfield Name	RW	Reset	Description
[31]	Mute	R	0	Mute support: 1 = yes 0 = no.
[30.:23]	Rsvd3	R	00	Reserved.
[22.:16]	StepSize	R	05	Size of each step in the gain range: 0 to 127 = .25dB to 32dB in .25dB steps.
[15]	Rsvd2	R	0	Reserved.
[14.:8]	NumSteps	R	1F	Number of gains steps (number of possible settings - 1).
[7]	Rsvd1	R	0	Reserved.
[6.:0]	Offset	R	1F	Indicates which step is 0dB

5.23.5. *MixerOutVol OutAmpLeft*

	Verb ID	Payload	Response
Get	BA0	00	See bitfield table.

5.23.5.1. *MixerOutVol OutAmpLeft*

Bit	Bitfield Name	RW	Reset	Description
[31.:8]	Rsvd2	R	000000	Reserved.
[7]	Mute	RW	1	Amp mute: 1 = muted 0 = not muted.
[6.:5]	Rsvd1	R	0	Reserved.
[4.:0]	Gain	RW	1F	Amp gain step number (see OutAmp-Cap parameter pertaining to this widget).

5.23.6. *MixerOutVol OutAmpRight0*

	Verb ID	Payload	Response
Get	B80	00	See bitfield table.

5.23.6.1. *MixerOutVol OutAmpRight*

Bit	Bitfield Name	RW	Reset	Description
[31.:8]	Rsvd2	R	000000	Reserved.
[7]	Mute	RW	1	Amp mute: 1 = muted 0 = not muted.
[6.:5]	Rsvd1	R	0	Reserved.
[4.:0]	Gain	RW	1F	Amp gain step number (see OutAmp-Cap parameter pertaining to this widget).

5.24. VolumeKnob Node (NID = 1F)

5.24.1. *VolumeKnob WCap*

	Verb ID	Payload	Response
Get	F00	09	See bitfield table.

5.24.1.1. *VolumeKnob WCap*

Bit	Bitfield Name	RW	Reset	Description
[31.:24]	Rsvd2	R	00	Reserved.
[23.:20]	Type	R	6	Widget type: 0h = Out Converter; 1h = In Converter; 2h = Summing (Mixer); 3h = Selector (Mux); 4h = Pin Complex; 5h = Power; 6h = Volume Knob; 7h = Beep Generator; 8h-Eh = Reserved; Fh = Vendor Defined
[19.:0]	Rsvd1	R	0	Reserved.

5.24.2. *VolumeKnob VolKnobCap*

	Verb ID	Payload	Response
Get	F00	13	See bitfield table.

5.24.2.1. *VolumeKnob VolKnobCap*

Bit	Bitfield Name	RW	Reset	Description
[31.:8]	Rsvd	R	000000	Reserved.
[7]	Delta	R	1	Indicates if software can write a base volume to the Volume Control Knob.
[6.:0]	NumSteps	R	7F	Number of gains steps (number of possible settings - 1).

5.24.3. *VolumeKnob ConLst*

	Verb ID	Payload	Response
Get	F00	0E	See bitfield table.

5.24.3.1. *VolumeKnob ConLst*

Bit	Bitfield Name	RW	Reset	Description
[31.:8]	Rsvd	R	000000	Reserved.
[7]	LForm	R	0	Connection list format: 1 = long-form (15-bit) NID entries, 0 = short-form (7-bit) NID entries.
[6.:0]	ConL	R	02	Number of NID entries in connection list.

5.24.4. *VolumeKnob ConLstEntry0*

	Verb ID	Payload	Response
Get	F02	00	See bitfield table.

5.24.4.1. *VolumeKnob ConLstEntry0*

Bit	Bitfield Name	RW	Reset	Description
[31.:24]	ConL3	R	00	Unused list entry.
[23.:16]	ConL2	R	00	Unused list entry.
[15]	ConL1Range	R	1	1 = ConL0..ConL1 defines a range of selectable inputs.
[14.:8]	ConL1	R	19	DAC4 Converter widget (0x19)
[7.:0]	ConL0	R	15	DAC0 Converter widget (0x15)

5.24.5. *VolumeKnob UnsolResp*

	Verb ID	Payload	Response
Get	F08	00	See bitfield table.

5.24.5.1. *VolumeKnob UnsolResp*

Bit	Bitfield Name	RW	Reset	Description
[31.:8]	Rsvd2	R	000000	Reserved.
[7]	En	RW	0	Unsolicited response enable: 1 = enabled, 0 = disabled.
[6]	Rsvd1	R	0	Reserved.
[5.:0]	Tag	RW	00	Software programmable field returned in top six bits (31:26) of every Unsolicited Response generated by this node.

5.24.6. *VolumeKnob Cntrl*

	Verb ID	Payload	Response
Get	F0F	00	See bitfield table.

5.24.6.1. *VolumeKnob Cntrl*

Bit	Bitfield Name	RW	Reset	Description
[31.:8]	Rsvd	R	000000	Reserved.
[7]	Direct	RW	0	Direct = 1 causes the volume control to directly control the hardware volume of the slave amps. Direct = 0 causes unsolicited responses to be generated.
[6.:0]	Volume	RW	7F	Volume, specified in steps of amplifier gain

5.24.7. *VolumeKnob VS*

	Verb ID	Payload	Response
Get	FE0	00	See bitfield table.

5.24.7.1. *VolumeKnob VS*

Bit	Bitfield Name	RW	Reset	Description
[31..3]	Rsvd	R	0000000	Reserved.
[4]	Continuous	RW	1	Allow continuous incrementing/decrementing of the volume knob value.
[3..1]	Rate	RW	0	Volume knob update rate, for continuous mode and de-bouncing (0..7 = 2.5..20Hz, in increments of 2.5Hz)
[0]	Enable	RW	0	Volume knob enable: 0 = DMic uses external pins, 1 = Volume knob uses external pins.

5.25. ADC0Mux Node (NID = 20)

5.25.1. *ADC0Mux WCap*

	Verb ID	Payload	Response
Get	F00	09	See bitfield table.

5.25.1.1. *ADC0Mux WCap*

Bit	Bitfield Name	RW	Reset	Description
[31..24]	Rsvd2	R	00	Reserved.
[23..20]	Type	R	3	Widget type: 0h = Out Converter; 1h = In Converter; 2h = Summing (Mixer); 3h = Selector (Mux); 4h = Pin Complex; 5h = Power; 6h = Volume Knob; 7h = Beep Generator; 8h-Eh = Reserved; Fh = Vendor Defined
[19..16]	Delay	R	0	Number of sample delays through widget.
[15..12]	Rsvd1	R	0	Reserved.
[11]	SwapCap	R	1	Left/right swap support: 1 = yes 0 = no.
[10]	PwrCntrl	R	0	Power state support: 1 = yes 0 = no.

5.25.1.1. *ADC0Mux WCap*

Bit	Bitfield Name	RW	Reset	Description
[9]	DigitalStrm	R	0	Digital stream support: 1 = yes (digital) 0 = no (analog).
[8]	ConnList	R	1	Connection list present: 1 = yes 0 = no.
[7]	UnsolCap	R	0	Unsolicited response support: 1 = yes 0 = no.
[6]	ProcWidget	R	0	Processing state support: 1 = yes 0 = no.
[5]	Stripe	R	0	Striping support: 1 = yes 0 = no.
[4]	FormatOvr	R	0	Stream format override: 1 = yes 0 = no.
[3]	AmpParamOvr	R	1	Amplifier capabilities override: 1 = yes no.
[2]	OutAmpPrsnt	R	1	Output amp present: 1 = yes 0 = no.
[1]	InAmpPrsnt	R	0	Input amp present: 1 = yes 0 = no.
[0]	Stereo	R	1	Stereo stream support: 1 = yes (stereo) 0 = no (mono).

5.25.2. *ADC0Mux ConLst*

	Verb ID	Payload	Response
Get	F00	0E	See bitfield table.

5.25.2.1. *ADC0Mux ConLst*

Bit	Bitfield Name	RW	Reset	Description
[31..8]	Rsvd	R	000000	Reserved.
[7]	LForm	R	0	Connection list format: 1 = long-form (15-bit) NID entries 0 = short-form (7-bit) NID entries.
[6..0]	ConL	R	03	Number of NID entries in connection list.

5.25.3. ADC0Mux ConLstEntry0

	Verb ID	Payload	Response
Get	F02	00	See bitfield table.

5.25.3.1. ADC0Mux ConLstEntry0

Bit	Bitfield Name	RW	Reset	Description
[31.:24]	ConL3	R	00	Unused list entry
[23.:16]	ConL2	R	1D	Mixer Summing widget (0x1D)
[15]	ConL1Range	R	1	1 = ConL0..ConL1 defines a range of selectable inputs
[14.:8]	ConL1	R	14	DMic1 Pin widget (0x14)
[7.:0]	ConL0	R	0A	Port A Pin widget (0x0A)

5.25.4. ADC0Mux ConSelectCtrl

	Verb ID	Payload	Response
Get	F01	00	See bitfield table.

5.25.4.1. ADC0Mux ConSelectCtrl

Bit	Bitfield Name	RW	Reset	Description
[31.:2]	Rsvd	R	00000000	Reserved.
[1.:0]	Index	RW	0	Connection select control index.

5.25.5. ADC0Mux LR

	Verb ID	Payload	Response
Get	F0C	00	See bitfield table.

5.25.5.1. *ADC0Mux LR*

Bit	Bitfield Name	RW	Reset	Description
[31.:3]	Rsvd2	R	00000000	Reserved.
[2]	SwapEn	RW	0	Swap enable: 1 = L/R swap enabled 0 = L/R swap disabled.
[1.:0]	Rsvd1	R	0	Reserved.

5.25.6. *ADC0Mux OutAmpCap*

	Verb ID	Payload	Response
Get	F00	12	See bitfield table.

5.25.6.1. *ADC0Mux OutAmpCap*

Bit	Bitfield Name	RW	Reset	Description
[31]	Mute	R	1	Mute support: 1 = yes 0 = no.
[30.:23]	Rsvd3	R	00	Reserved.
[22.:16]	StepSize	R	05	Size of each step in the gain range: 0 to 127 = .25dB to 32dB in .25dB steps.
[15]	Rsvd2	R	0	Reserved.
[14.:8]	NumSteps	R	0F	Number of gains steps (number of possible settings - 1).
[7]	Rsvd1	R	0	Reserved.
[6.:0]	Offset	R	00	Indicates which step is 0dB

5.25.7. *ADC0Mux OutAmpLeft*

	Verb ID	Payload	Response
Get	BA0	00	See bitfield table.

5.25.7.1. *ADC0Mux OutAmpLeft*

Bit	Bitfield Name	RW	Reset	Description
[31.:8]	Rsvd2	R	000000	Reserved.
[7]	Mute	RW	1	Amp mute: 1 = muted 0 = not muted.
[6.:4]	Rsvd1	R	0	Reserved.
[3.:0]	Gain	RW	0	Amp gain step number (see OutAmp-Cap parameter pertaining to this widget).

5.25.8. *ADC0Mux OutAmpRight*

	Verb ID	Payload	Response
Get	B80	00	See bitfield table.

5.25.8.1. *ADC0Mux OutAmpRight*

Bit	Bitfield Name	RW	Reset	Description
[31.:8]	Rsvd2	R	000000	Reserved.
[7]	Mute	RW	1	Amp mute: 1 = muted 0 = not muted.
[6.:4]	Rsvd1	R	0	Reserved.
[3.:0]	Gain	RW	0	Amp gain step number (see OutAmp-Cap parameter pertaining to this widget).

5.26. *ADC1Mux Node (NID = 21)*5.26.1. *ADC1Mux WCap*

	Verb ID	Payload	Response
Get	F00	09	See bitfield table.

5.26.1.1. ADC1Mux WCap

Bit	Bitfield Name	RW	Reset	Description
[31.:24]	Rsvd2	R	00	Reserved.
[23.:20]	Type	R	3	Widget type: 0h = Out Converter; 1h = In Converter; 2h = Summing (Mixer); 3h = Selector (Mux); 4h = Pin Complex; 5h = Power; 6h = Volume Knob; 7h = Beep Generator; 8h-Eh = Reserved; Fh = Vendor Defined
[19.:16]	Delay	R	0	Number of sample delays through widget.
[15.:12]	Rsvd1	R	0	Reserved.
[11]	SwapCap	R	1	Left/right swap support: 1 = yes 0 = no.
[10]	PwrCntrl	R	0	Power state support: 1 = yes 0 = no.
[9]	DigitalStrm	R	0	Digital stream support: 1 = yes (digital) 0 = no (analog).
[8]	ConnList	R	1	Connection list present: 1 = yes 0 = no.
[7]	UnsolCap	R	0	Unsolicited response support: 1 = yes 0 = no.
[6]	ProcWidget	R	0	Processing state support: 1 = yes 0 = no.
[5]	Stripe	R	0	Striping support: 1 = yes 0 = no.
[4]	FormatOvrd	R	0	Stream format override: 1 = yes 0 = no.
[3]	AmpParamOvrd	R	1	Amplifier capabilities override: 1 = yes no.
[2]	OutAmpPrsnt	R	1	Output amp present: 1 = yes 0 = no.
[1]	InAmpPrsnt	R	0	Input amp present: 1 = yes 0 = no.
[0]	Stereo	R	1	Stereo stream support: 1 = yes (stereo) 0 = no (mono).

5.26.2. ADC1Mux ConLst

	Verb ID	Payload	Response
Get	F00	0E	See bitfield table.

5.26.2.1. ADC1Mux ConLst

Bit	Bitfield Name	RW	Reset	Description
[31..8]	Rsvd	R	000000	Reserved.
[7]	LForm	R	0	Connection list format: 1 = long-form (15-bit) NID entries 0 = short-form (7-bit) NID entries.
[6..0]	ConL	R	04	Number of NID entries in connection list.

5.26.3. ADC1Mux ConLstEntry0

	Verb ID	Payload	Response
Get	F02	00	See bitfield table.

5.26.3.1. ADC1Mux ConLstEntry0

Bit	Bitfield Name	RW	Reset	Description
[31..24]	ConL3	R	00	Unused list entry
[23..16]	ConL2	R	1D	Mixer Summing widget (0x1D)
[15]	ConL1Range	R	1	1 = ConL0..ConL1 defines a range of selectable inputs
[14..8]	ConL1	R	14	DMic1 Pin widget (0x14)
[7..0]	ConL0	R	0A	Port A Pin widget (0x0A)

5.26.4. ADC1Mux ConSelectCtrl

	Verb ID	Payload	Response
Get	F01	00	See bitfield table.

5.26.4.1. ADC1Mux ConSelectCtrl

Bit	Bitfield Name	RW	Reset	Description
[31..2]	Rsvd	R	00000000	Reserved.
[1..0]	Index	RW	0	Connection select control index.

5.26.5. ADC1Mux LR

	Verb ID	Payload	Response
Get	F0C	00	See bitfield table.

5.26.5.1. ADC1Mux LR

Bit	Bitfield Name	RW	Reset	Description
[31..3]	Rsvd2	R	00000000	Reserved.
[2]	SwapEn	RW	0	Swap enable: 1 = L/R swap enabled 0 = L/R swap disabled.
[1..0]	Rsvd1	R	0	Reserved.

5.26.6. ADC1Mux OutAmpCap

	Verb ID	Payload	Response
Get	F00	12	See bitfield table.

5.26.6.1. *ADC1Mux OutAmpCap*

Bit	Bitfield Name	RW	Reset	Description
[31]	Mute	R	1	Mute support: 1 = yes 0 = no.
[30..23]	Rsvd3	R	00	Reserved.
[22..16]	StepSize	R	05	Size of each step in the gain range: 0 to 127 = .25dB to 32dB in .25dB steps.
[15]	Rsvd2	R	0	Reserved.
[14..8]	NumSteps	R	0F	Number of gains steps (number of possible settings - 1).
[7]	Rsvd1	R	0	Reserved.
[6..0]	Offset	R	00	Indicates which step is 0dB

5.26.7. *ADC1Mux OutAmpLeft*

	Verb ID	Payload	Response
Get	BA0	00	See bitfield table.

5.26.7.1. *ADC1Mux OutAmpLeft*

Bit	Bitfield Name	RW	Reset	Description
[31..8]	Rsvd2	R	000000	Reserved.
[7]	Mute	RW	1	Amp mute: 1 = muted 0 = not muted.
[6..4]	Rsvd1	R	0	Reserved.
[3..0]	Gain	RW	0	Amp gain step number (see OutAmp-Cap parameter pertaining to this widget).

5.26.8. ADC1Mux OutAmpRight

	Verb ID	Payload	Response
Get	B80	00	See bitfield table.

5.26.8.1. ADC1Mux OutAmpRight

Bit	Bitfield Name	RW	Reset	Description
[31..8]	Rsvd2	R	000000	Reserved.
[7]	Mute	RW	1	Amp mute: 1 = muted 0 = not muted.
[6..4]	Rsvd1	R	0	Reserved.
[3..0]	Gain	RW	0	Amp gain step number (see OutAmp-Cap parameter pertaining to this widget).

5.27. Dig0Pin Node (NID = 22)**5.27.1. Dig0Pin WCap**

	Verb ID	Payload	Response
Get	F00	09	See bitfield table.

5.27.1.1. Dig0Pin WCap

Bit	Bitfield Name	RW	Reset	Description
[31..24]	Rsvd2	R	00	Reserved.
[23..20]	Type	R	4	Widget type: 0h = Out Converter; 1h = In Converter; 2h = Summing (Mixer); 3h = Selector (Mux); 4h = Pin Complex; 5h = Power; 6h = Volume Knob; 7h = Beep Generator; 8h-Eh = Reserved; Fh = Vendor Defined
[19..16]	Delay	R	0	Number of sample delays through widget.
[15..12]	Rsvd1	R	0	Reserved.
[11]	SwapCap	R	0	Left/right swap support: 1 = yes 0 = no.

5.27.1.1. *Dig0Pin WCap*

Bit	Bitfield Name	RW	Reset	Description
[10]	PwrCntrl	R	0	Power state support: 1 = yes 0 = no.
[9]	Dig	R	1	Digital stream support: 1 = yes (digital) 0 = no (analog).
[8]	ConnList	R	1	Connection list present: 1 = yes 0 = no.
[7]	UnSolCap	R	0	Unsolicited response support: 1 = yes 0 = no.
[6]	ProcWidget	R	0	Processing state support: 1 = yes 0 = no.
[5]	Stripe	R	0	Striping support: 1 = yes 0 = no.
[4]	FormatOvrd	R	0	Stream format override: 1 = yes 0 = no.
[3]	AmpParOvrd	R	0	Amplifier capabilities override: 1 = yes no.
[2]	OutAmpPrsnt	R	0	Output amp present: 1 = yes 0 = no.
[1]	InAmpPrsnt	R	0	Input amp present: 1 = yes 0 = no.
[0]	Stereo	R	1	Stereo stream support: 1 = yes (stereo) 0 = no (mono).

5.27.2. *Dig0Pin PinCap*

	Verb ID	Payload	Response
Get	F00	0C	See bitfield table.

5.27.2.1. *Dig0Pin PinCap*

Bit	Bitfield Name	RW	Reset	Description
[31.:17]	Rsvd2	R	0000	Reserved.
[16]	EapdCap	R	0	EAPD support: 1 = yes 0 = no.

5.27.2.1. *Dig0Pin PinCap*

Bit	Bitfield Name	RW	Reset	Description
[15.:8]	VrefCntrl	R	00	Vref support: bit 7 = Reserved; bit 6 = Reserved; bit 5 = 100% support (1 = yes 0 = no); bit 4 = 80% support (1 = yes 0 = no); bit 3 = Reserved; bit 2 = GND support (1 = yes 0 = no); bit 1 = 50% support (1 = yes 0 = no); bit 0 = Hi-Z support (1 = yes 0 = no)
[7]	Rsvd1	R	0	Reserved.
[6]	BalancedIO	R	0	Balanced I/O support: 1 = yes 0 = no.
[5]	InCap	R	0	Input support: 1 = yes 0 = no.
[4]	OutCap	R	1	Output support: 1 = yes 0 = no.
[3]	HdphDrvCap	R	0	Headphone amp present: 1 = yes 0 = no.
[2]	PresDtctCap	R	0	Presence detection support: 1 = yes 0 = no.
[1]	TrigRqd	R	0	Trigger required for impedance sense: 1 = yes 0 = no.
[0]	ImpSenseCap	R	0	Impedance sense support: 1 = yes 0 = no.

5.27.3. *Dig0Pin ConLst*

	Verb ID	Payload	Response
Get	F00	0E	See bitfield table.

5.27.3.1. *Dig0Pin ConLst*

Bit	Bitfield Name	RW	Reset	Description
[31.:8]	Rsvd	R	000000	Reserved.
[7]	LForm	R	0	Connection list format: 1 = long-form (15-bit) NID entries 0 = short-form (7-bit) NID entries.
[6.:0]	ConL	R	03	Number of NID entries in connection list.

5.27.4. Dig0Pin ConLstEntry0

	Verb ID	Payload	Response
Get	F02	00	See bitfield table.

5.27.4.1. Dig0Pin ConLstEntry0

Bit	Bitfield Name	RW	Reset	Description
[31.:24]	ConL3	R	00	Unused list entry.
[23.:16]	ConL2	R	21	ADC1Mux Summing widget (0x21)
[15.:8]	ConL1	R	20	ADC0Mux Summing widget (0x20)
[7.:0]	ConL0	R	25	SPDIFOut0 Converter widget (0x25)

5.27.5. Dig0Pin ConSelectCtrl

	Verb ID	Payload	Response
Get	F01	00	See bitfield table.

5.27.5.1. Dig0Pin ConSelectCtrl

Bit	Bitfield Name	RW	Reset	Description
[31.:2]	Rsvd	R	00000000	Reserved.
[1.:0]	Index	RW	0	Connection select control index.

5.27.6. Dig0Pin PinWCntrl

	Verb ID	Payload	Response
Get	F07	00	See bitfield table.

5.27.6.1. *Dig0Pin PinWCntrl*

Bit	Bitfield Name	RW	Reset	Description
[31.:7]	Rsvd2	R	0000000	Reserved.
[6]	OutEn	RW	0	Output enable: 1 = enabled 0 = disabled.
[5.:0]	Rsvd1	R	00	Reserved.

5.27.7. *Dig0Pin ConfigDefault*

	Verb ID	Payload	Response
Get	F1C	00	See bitfield table.

5.27.7.1. *Dig0Pin ConfigDefault*

Bit	Bitfield Name	RW	Reset	Description
[31.:30]	PortConnectivity	RW	0	Port connectivity: 0h = Port complex is connected to a jack; 1h = No physical connection for port; 2h = Fixed function device is attached; 3h = Both jack and internal device attached (info in all other fields refers to integrated device any presence detection refers to jack)
[29.:24]	Location	RW	1	Location. Bits [5..4]: 0h = External on primary chassis; 1h = Internal; 2h = Separate chassis; 3h = Other. Bits [3..0]: 0h = N/A; 1h = Rear; 2h = Front; 3h = Left; 4h = Right; 5h = Top; 6h = Bottom; 7h-9h = Special; Ah-Fh = Reserved
[23.:20]	Device	RW	4	Default device: 0h = Line out; 1h = Speaker; 2h = HP out; 3h = CD; 4h = SPDIF Out; 5h = Digital other out; 6h = Modem line side; 7h = Modem handset side; 8h = Line in; 9h = Aux; Ah = Mic in; Bh = Telephony; Ch = SPDIF In; Dh = Digital other in; Eh = Reserved; Fh = Other

5.27.7.1. *Dig0Pin ConfigDefault*

Bit	Bitfield Name	RW	Reset	Description
[19.:16]	ConnectionType	RW	5	Connection type: 0h = Unknown; 1h = 1/8" stereo/mono; 2h = 1/4" stereo/mono; 3h = ATAPI internal; 4h = RCA; 5h = Optical; 6h = Other digital; 7h = Other analog; 8h = Multichannel analog (DIN); 9h = XLR/Professional; Ah = RJ-11 (modem); Bh = Combination; Ch-Eh = Reserved; Fh = Other
[15.:12]	Color	RW	1	Color: 0h = Unknown; 1h = Black; 2h = Grey; 3h = Blue; 4h = Green; 5h = Red; 6h = Orange; 7h = Yellow; 8h = Purple; 9h = Pink; Ah-Dh = Reserved; Eh = White; Fh = Other
[11.:8]	Misc	RW	0	Miscellaneous: Bits [3..1] = Reserved; Bit 0 = Jack detect override
[7.:4]	Association	RW	5	Default association.
[3.:0]	Sequence	RW	0	Sequence.

5.28. Dig1Pin Node (NID = 23)

5.28.1. *Dig1Pin WCap*

	Verb ID	Payload	Response
Get	F00	09	See bitfield table.

5.28.1.1. *Dig1Pin WCap*

Bit	Bitfield Name	RW	Reset	Description
[31.:24]	Rsvd2	R	00	Reserved.
[23.:20]	Type	R	4	Widget type: 0h = Out Converter; 1h = In Converter; 2h = Summing (Mixer); 3h = Selector (Mux); 4h = Pin Complex; 5h = Power; 6h = Volume Knob; 7h = Beep Generator; 8h-Eh = Reserved; Fh = Vendor Defined
[19.:16]	Delay	R	0	Number of sample delays through widget.

5.28.1.1. *Dig1Pin WCap*

Bit	Bitfield Name	RW	Reset	Description
[15.:12]	Rsvd1	R	0	Reserved.
[11]	SwapCap	R	0	Left/right swap support: 1 = yes 0 = no.
[10]	PwrCntrl	R	0	Power state support: 1 = yes 0 = no.
[9]	Dig	R	1	Digital stream support: 1 = yes (digital) 0 = no (analog).
[8]	ConnList	R	1	Connection list present: 1 = yes 0 = no.
[7]	UnSolCap	R	0	Unsolicited response support: 1 = yes 0 = no.
[6]	ProcWidget	R	0	Processing state support: 1 = yes 0 = no.
[5]	Stripe	R	0	Striping support: 1 = yes 0 = no.
[4]	FormatOvrd	R	0	Stream format override: 1 = yes 0 = no.
[3]	AmpParOvrd	R	0	Amplifier capabilities override: 1 = yes no.
[2]	OutAmpPrsnt	R	0	Output amp present: 1 = yes 0 = no.
[1]	InAmpPrsnt	R	0	Input amp present: 1 = yes 0 = no.
[0]	Stereo	R	1	Stereo stream support: 1 = yes (stereo) 0 = no (mono).

5.28.2. *Dig1Pin PinCap*

	Verb ID	Payload	Response
Get	F00	0C	See bitfield table.

5.28.2.1. *Dig1Pin PinCap*

Bit	Bitfield Name	RW	Reset	Description
[31.:17]	Rsvd2	R	0000	Reserved.
[16]	EapdCap	R	0	EAPD support: 1 = yes 0 = no.

5.28.2.1. *Dig1Pin PinCap*

Bit	Bitfield Name	RW	Reset	Description
[15.:8]	VrefCntrl	R	00	Vref support: bit 7 = Reserved; bit 6 = Reserved; bit 5 = 100% support (1 = yes 0 = no); bit 4 = 80% support (1 = yes 0 = no); bit 3 = Reserved; bit 2 = GND support (1 = yes 0 = no); bit 1 = 50% support (1 = yes 0 = no); bit 0 = Hi-Z support (1 = yes 0 = no)
[7]	Rsvd1	R	0	Reserved.
[6]	BalancedIO	R	0	Balanced I/O support: 1 = yes 0 = no.
[5]	InCap	R	0	Input support: 1 = yes 0 = no.
[4]	OutCap	R	1	Output support: 1 = yes 0 = no.
[3]	HdphDrvCap	R	0	Headphone amp present: 1 = yes 0 = no.
[2]	PresDtctCap	R	0	Presence detection support: 1 = yes 0 = no.
[1]	TrigRqd	R	0	Trigger required for impedance sense: 1 = yes 0 = no.
[0]	ImpSenseCap	R	0	Impedance sense support: 1 = yes 0 = no.

5.28.3. *Dig1Pin ConLst*

	Verb ID	Payload	Response
Get	F00	0E	See bitfield table.

5.28.3.1. *Dig1Pin ConLst*

Bit	Bitfield Name	RW	Reset	Description
[31.:8]	Rsvd	R	000000	Reserved.
[7]	LForm	R	0	Connection list format: 1 = long-form (15-bit) NID entries 0 = short-form (7-bit) NID entries.
[6.:0]	ConL	R	03	Number of NID entries in connection list.

5.28.4. Dig1Pin ConLstEntry0

	Verb ID	Payload	Response
Get	F02	00	See bitfield table.

5.28.4.1. Dig1Pin ConLstEntry0

Bit	Bitfield Name	RW	Reset	Description
[31.:24]	ConL3	R	00	Unused list entry.
[23.:16]	ConL2	R	21	ADC1Mux Summing widget (0x21)
[15.:8]	ConL1	R	20	ADC0Mux Summing widget (0x20)
[7.:0]	ConL0	R	26	SPDIFOut1 Converter widget (0x26)

5.28.5. Dig1Pin ConSelectCtrl

	Verb ID	Payload	Response
Get	F01	00	See bitfield table.

5.28.5.1. Dig1Pin ConSelectCtrl

Bit	Bitfield Name	RW	Reset	Description
[31.:2]	Rsvd	R	00000000	Reserved.
[1.:0]	Index	RW	0	Connection select control index.

5.28.6. Dig1Pin PinWCntrl

	Verb ID	Payload	Response
Get	F07	00	See bitfield table.

5.28.6.1. *Dig1Pin PinWCntrl*

Bit	Bitfield Name	RW	Reset	Description
[31.:7]	Rsvd2	R	0000000	Reserved.
[6]	OutEn	RW	0	Output enable: 1 = enabled 0 = disabled.
[5.:0]	Rsvd1	R	00	Reserved.

5.28.7. *Dig1Pin ConfigDefault*

	Verb ID	Payload	Response
Get	F1C	00	See bitfield table.

5.28.7.1. *Dig1Pin ConfigDefault*

Bit	Bitfield Name	RW	Reset	Description
[31.:30]	PortConnectivity	RW	2	Port connectivity: 0h = Port complex is connected to a jack; 1h = No physical connection for port; 2h = Fixed function device is attached; 3h = Both jack and internal device attached (info in all other fields refers to integrated device any presence detection refers to jack)
[29.:24]	Location	RW	18	Location. Bits [5..4]: 0h = External on primary chassis; 1h = Internal; 2h = Separate chassis; 3h = Other. Bits [3..0]: 0h = N/A; 1h = Rear; 2h = Front; 3h = Left; 4h = Right; 5h = Top; 6h = Bottom; 7h-9h = Special; Ah-Fh = Reserved
[23.:20]	Device	RW	5	Default device: 0h = Line out; 1h = Speaker; 2h = HP out; 3h = CD; 4h = SPDIF Out; 5h = Digital other out; 6h = Modem line side; 7h = Modem handset side; 8h = Line in; 9h = Aux; Ah = Mic in; Bh = Telephony; Ch = SPDIF In; Dh = Digital other in; Eh = Reserved; Fh = Other

5.28.7.1. *Dig1Pin ConfigDefault*

Bit	Bitfield Name	RW	Reset	Description
[19.:16]	ConnectionType	RW	6	Connection type: 0h = Unknown; 1h = 1/8" stereo/mono; 2h = 1/4" stereo/mono; 3h = ATAPI internal; 4h = RCA; 5h = Optical; 6h = Other digital; 7h = Other analog; 8h = Multichannel analog (DIN); 9h = XLR/Professional; Ah = RJ-11 (modem); Bh = Combination; Ch-Eh = Reserved; Fh = Other
[15.:12]	Color	RW	0	Color: 0h = Unknown; 1h = Black; 2h = Grey; 3h = Blue; 4h = Green; 5h = Red; 6h = Orange; 7h = Yellow; 8h = Purple; 9h = Pink; Ah-Dh = Reserved; Eh = White; Fh = Other
[11.:8]	Misc	RW	0	Miscellaneous: Bits [3..1] = Reserved; Bit 0 = Jack detect override
[7.:4]	Association	RW	6	Default association.
[3.:0]	Sequence	RW	0	Sequence.

5.29. Dig2Pin Node (NID = 24)

5.29.1. *Dig2Pin WCap*

	Verb ID	Payload	Response
Get	F00	09	See bitfield table.

5.29.1.1. *Dig2Pin WCap*

Bit	Bitfield Name	RW	Reset	Description
[31.:24]	Rsvd2	R	00	Reserved.
[23.:20]	Type	R	4	Widget type: 0h = Out Converter; 1h = In Converter; 2h = Summing (Mixer); 3h = Selector (Mux); 4h = Pin Complex; 5h = Power; 6h = Volume Knob; 7h = Beep Generator; 8h-Eh = Reserved; Fh = Vendor Defined
[19.:16]	Delay	R	0	Number of sample delays through widget.

5.29.1.1. *Dig2Pin WCap*

Bit	Bitfield Name	RW	Reset	Description
[15.:12]	Rsvd1	R	0	Reserved.
[11]	SwapCap	R	0	Left/right swap support: 1 = yes 0 = no.
[10]	PwrCntrl	R	0	Power state support: 1 = yes 0 = no.
[9]	Dig	R	1	Digital stream support: 1 = yes (digital) 0 = no (analog).
[8]	ConnList	R	0	Connection list present: 1 = yes 0 = no.
[7]	UnSolCap	R	0	Unsolicited response support: 1 = yes 0 = no.
[6]	ProcWidget	R	0	Processing state support: 1 = yes 0 = no.
[5]	Stripe	R	0	Striping support: 1 = yes 0 = no.
[4]	FormatOvrd	R	0	Stream format override: 1 = yes 0 = no.
[3]	AmpParOvrd	R	0	Amplifier capabilities override: 1 = yes no.
[2]	OutAmpPrsnt	R	0	Output amp present: 1 = yes 0 = no.
[1]	InAmpPrsnt	R	0	Input amp present: 1 = yes 0 = no.
[0]	Stereo	R	1	Stereo stream support: 1 = yes (stereo) 0 = no (mono).

5.29.2. *Dig2Pin PinCap*

	Verb ID	Payload	Response
Get	F00	0C	See bitfield table.

5.29.2.1. *Dig2Pin PinCap*

Bit	Bitfield Name	RW	Reset	Description
[31.:17]	Rsvd2	R	0000	Reserved.
[16]	EapdCap	R	0	EAPD support: 1 = yes 0 = no.

5.29.2.1. *Dig2Pin PinCap*

Bit	Bitfield Name	RW	Reset	Description
[15.:8]	VrefCntrl	R	00	Vref support: bit 7 = Reserved; bit 6 = Reserved; bit 5 = 100% support (1 = yes 0 = no); bit 4 = 80% support (1 = yes 0 = no); bit 3 = Reserved; bit 2 = GND support (1 = yes 0 = no); bit 1 = 50% support (1 = yes 0 = no); bit 0 = Hi-Z support (1 = yes 0 = no)
[7]	Rsvd1	R	0	Reserved.
[6]	BalancedIO	R	0	Balanced I/O support: 1 = yes 0 = no.
[5]	InCap	R	1	Input support: 1 = yes 0 = no.
[4]	OutCap	R	0	Output support: 1 = yes 0 = no.
[3]	HdphDrvCap	R	0	Headphone amp present: 1 = yes 0 = no.
[2]	PresDtctCap	R	1	Presence detection support: 1 = yes 0 = no.
[1]	TrigRqd	R	0	Trigger required for impedance sense: 1 = yes 0 = no.
[0]	ImpSenseCap	R	0	Impedance sense support: 1 = yes 0 = no.

5.29.3. *Dig2Pin PinWCntrl*

	Verb ID	Payload	Response
Get	F07	00	See bitfield table.

5.29.3.1. *Dig2Pin PinWCntrl*

Bit	Bitfield Name	RW	Reset	Description
[31.:7]	Rsvd2	R	0000000	Reserved.
[6]	1nEn	RW	0	input enable: 1 = enabled 0 = disabled.
[5.:0]	Rsvd1	R	00	Reserved.

5.29.4. Dig2Pin UnsolResp

	Verb ID	Payload	Response
Get	F08	00	See bitfield table.

5.29.4.1. Dig2Pin UnsolResp

Bit	Bitfield Name	RW	Reset	Description
[31..8]	Rsvd2	R	000000	Reserved.
[7]	En	RW	0	Unsolicited response enable: 1 = enabled, 0 = disabled.
[6]	Rsvd1	R	0	Reserved.
[5..0]	Tag	RW	00	Software programmable field returned in top six bits (31:26) of every Unsolicited Response generated by this node.

5.29.5. Dig2Pin ChSense

	Verb ID	Payload	Response
Get	F09	00	See bitfield table.

5.29.5.1. Dig2Pin ChSense

Bit	Bitfield Name	RW	Reset	Description
[31]	PresDtct	R	0	Presence detection indicator: 1 = presence detected; 0 = presence not detected.
[30..0]	Rsvd	R	0	Reserved.

5.29.6. Dig2Pin PwrState

	Verb ID	Payload	Response
Get	F05	00	See bitfield table.

5.29.6.1. *Dig2Pin PwrState*

Bit	Bitfield Name	RW	Reset	Description
[31.:6]	Rsvd2	R	0000000	Reserved.
[5.:4]	Act	R	3	Actual power state of this widget.
[3.:2]	Rsvd1	R	0	Reserved.
[1.:0]	Set	RW	3	Current power state setting for this widget, used for EAPD control in this case: 0h-1h = Pin drives the value of the EAPD control bit 2h-3h = Pin tri-stated

5.29.7. *Dig2Pin EAPD*

	Verb ID	Payload	Response
Get	F0C	00	See bitfield table.

5.29.7.1. *Dig2Pin EAPD*

Bit	Bitfield Name	RW	Reset	Description
[31.:2]	Rsvd2	R	00000000	Reserved.
[1]	Control	RW	0	EAPD value reflected on the EAPD pin: 0 = Power down external amplifier; 1 = Power up external amplifier
[0]	Rsvd1	R	0	Reserved.

5.29.8. *Dig2Pin ConfigDefault*

	Verb ID	Payload	Response
Get	F1C	00	See bitfield table.

5.29.8.1. Dig2Pin ConfigDefault

Bit	Bitfield Name	RW	Reset	Description
[31..:30]	PortConnectivity	RW	0	Port connectivity: 0h = Port complex is connected to a jack; 1h = No physical connection for port; 2h = Fixed function device is attached; 3h = Both jack and internal device attached (info in all other fields refers to integrated device any presence detection refers to jack)
[29..:24]	Location	RW	01	Location. Bits [5..4]: 0h = External on primary chassis; 1h = Internal; 2h = Separate chassis; 3h = Other. Bits [3..0]: 0h = N/A; 1h = Rear; 2h = Front; 3h = Left; 4h = Right; 5h = Top; 6h = Bottom; 7h-9h = Special; Ah-Fh = Reserved
[23..:20]	Device	RW	C	Default device: 0h = Line out; 1h = Speaker; 2h = HP out; 3h = CD; 4h = SPDIF Out; 5h = Digital other out; 6h = Modem line side; 7h = Modem handset side; 8h = Line in; 9h = Aux; Ah = Mic in; Bh = Telephony; Ch = SPDIF In; Dh = Digital other in; Eh = Reserved; Fh = Other
[19..:16]	ConnectionType	RW	5	Connection type: 0h = Unknown; 1h = 1/8" stereo/mono; 2h = 1/4" stereo/mono; 3h = ATAPI internal; 4h = RCA; 5h = Optical; 6h = Other digital; 7h = Other analog; 8h = Multichannel analog (DIN); 9h = XLR/Professional; Ah = RJ-11 (modem); Bh = Combination; Ch-Eh = Reserved; Fh = Other
[15..:12]	Color	RW	2	Color: 0h = Unknown; 1h = Black; 2h = Grey; 3h = Blue; 4h = Green; 5h = Red; 6h = Orange; 7h = Yellow; 8h = Purple; 9h = Pink; Ah-Dh = Reserved; Eh = White; Fh = Other
[11..:8]	Misc	RW	0	Miscellaneous: Bits [3..1] = Reserved; Bit 0 = Jack detect override
[7..:4]	Association	RW	8	Default association.
[3..:0]	Sequence	RW	0	Sequence.

5.30. SPDIFOut0 Node (NID = 25)

5.30.1. SPDIFOut0 WCap

	Verb ID	Payload	Response
Get	F00	09	See bitfield table.

5.30.1.1. SPDIFOut0 WCap

Bit	Bitfield Name	RW	Reset	Description
[31..24]	Rsvd2	R	00	Reserved.
[23..20]	Type	R	0	Widget type: 0h = Out Converter; 1h = In Converter; 2h = Summing (Mixer); 3h = Selector (Mux); 4h = Pin Complex; 5h = Power; 6h = Volume Knob; 7h = Beep Generator; 8h-Eh = Reserved; Fh = Vendor Defined
[19..16]	Delay	R	4	Number of sample delays through widget.
[15..12]	Rsvd1	R	0	Reserved.
[11]	SwapCap	R	0	Left/right swap support: 1 = yes 0 = no.
[10]	PwrCntrl	R	0	Power state support: 1 = yes 0 = no.
[9]	Dig	R	1	Digital stream support: 1 = yes (digital) 0 = no (analog).
[8]	ConnList	R	0	Connection list present: 1 = yes 0 = no.
[7]	UnSolCap	R	0	Unsolicited response support: 1 = yes 0 = no.
[6]	ProcWidget	R	0	Processing state support: 1 = yes 0 = no.
[5]	Stripe	R	0	Striping support: 1 = yes 0 = no.
[4]	FormatOvrd	R	1	Stream format override: 1 = yes 0 = no.
[3]	AmpParOvrd	R	1	Amplifier capabilities override: 1 = yes no.
[2]	OutAmpPrsnt	R	1	Output amp present: 1 = yes 0 = no.

5.30.1.1. *SPDIFOut0 WCap*

Bit	Bitfield Name	RW	Reset	Description
[1]	InAmpPrsnt	R	0	Input amp present: 1 = yes 0 = no.
[0]	Stereo	R	1	Stereo stream support: 1 = yes (stereo) 0 = no (mono).

5.30.2. *SPDIFOut0 PCMCap*

	Verb ID	Payload	Response
Get	F00	0A	See bitfield table.

5.30.2.1. *SPDIFOut0 PCMCap*

Bit	Bitfield Name	RW	Reset	Description
[31..21]	Rsvd2	R	000	Reserved.
[20]	B32	R	0	32 bit audio format support: 1 = yes, 0 = no.
[19]	B24	R	1	24 bit audio format support: 1 = yes, 0 = no.
[18]	B20	R	1	20 bit audio format support: 1 = yes, 0 = no.
[17]	B16	R	1	16 bit audio format support: 1 = yes, 0 = no.
[16]	B8	R	0	8 bit audio format support: 1 = yes, 0 = no.
[15..12]	Rsvd1	R	0	Reserved.
[11]	R12	R	0	384kHz rate support: 1 = yes, 0 = no.
[10]	R11	R	1	192kHz rate support: 1 = yes, 0 = no.
[9]	R10	R	1	176.4kHz rate support: 1 = yes, 0 = no.
[8]	R9	R	1	96kHz rate support: 1 = yes, 0 = no.
[7]	R8	R	1	88.2kHz rate support: 1 = yes, 0 = no.
[6]	R7	R	1	48kHz rate support: 1 = yes, 0 = no.
[5]	R6	R	1	44.1kHz rate support: 1 = yes, 0 = no.

5.30.2.1. SPDIFOut0 PCMCap

Bit	Bitfield Name	RW	Reset	Description
[4]	R5	R	0	32kHz rate support: 1 = yes, 0 = no.
[3]	R4	R	0	22.05kHz rate support: 1 = yes, 0 = no.
[2]	R3	R	0	16kHz rate support: 1 = yes, 0 = no.
[1]	R2	R	0	11.025kHz rate support: 1 = yes, 0 = no.
[0]	R1	R	0	8kHz rate support: 1 = yes, 0 = no.

5.30.3. SPDIFOut0 StreamCap

	Verb ID	Payload	Response
Get	F00	0B	See bitfield table.

5.30.3.1. SPDIFOut0 StreamCap

Bit	Bitfield Name	RW	Reset	Description
[31..3]	Rsvd	R	00000000	Reserved.
[2]	AC3	R	1	AC-3 formatted data support: 1 = yes, 0 = no.
[1]	Float32	R	0	Float32 formatted data support: 1 = yes, 0 = no.
[0]	PCM	R	1	PCM-formatted data support: 1 = yes, 0 = no.

5.30.4. SPDIFOut0 Cnvtr

	Verb ID	Payload	Response
Get	A00	00	See bitfield table.

5.30.4.1. SPDIFOut0 Cnvtr

Bit	Bitfield Name	RW	Reset	Description
[31.:16]	Rsvd2	R	0000	Reserved.
[15]	FrmtNonPCM	RW	0	Stream type: 1 = Non-PCM, 0 = PCM.
[14]	FrmtSmplRate	RW	0	Sample base rate: 1 = 44.1kHz, 0 = 48kHz.
[13.:11]	SmplRateMultp	RW	0	Sample base rate multiple: 000b= x1 (48kHz/44.1kHz or less); 001b= x2 (96kHz/88.2kHz/32kHz); 010b= x3 (144kHz); 011b= x4 (192kHz/176.4kHz); 100b-111b Reserved
[10.:8]	SmplRateDiv	RW	0	Sample base rate divider: 000b= Divide by 1 (48kHz/44.1kHz); 001b= Divide by 2 (24kHz/20.05kHz); 010b= Divide by 3 (16kHz/32kHz); 011b= Divide by 4 (11.025kHz); 100b= Divide by 5 (9.6kHz); 101b= Divide by 6 (8kHz); 110b= Divide by 7; 111b= Divide by 8 (6kHz)
[7]	Rsvd1	R	0	Reserved.
[6.:4]	BitsPerSmpl	RW	3	Bits per sample: 000b= 8 bits; 001b= 16 bits; 010b= 20 bits; 011b= 24 bits; 100b= 32 bits; 101b-111b= Reserved
[3.:0]	NmbrChan	RW	1	Total number of channels in the stream assigned to this converter: 0000b-1111b= 1-16 channels.

5.30.5. SPDIFOut0 CnvtrID

	Verb ID	Payload	Response
Get	F06	00	See bitfield table.

5.30.5.1. SPDIFOut0 CnvtrID

Bit	Bitfield Name	RW	Reset	Description
[31.:8]	Rsvd	R	000000	Reserved.
[7.:4]	Strm	RW	0	Stream ID: 0h = Converter "off", 1h-Fh = valid IDs.
[3.:0]	Ch	RW	0	Channel assignment ("Ch" and "Ch+1" assigned as a pair, for a stereo converter).

5.30.6. SPDIFOut0 DigCnvtr

	Verb ID	Payload	Response
Get	F0D	00	See bitfield table.

5.30.6.1. SPDIFOut0 DigCnvtr

Bit	Bitfield Name	RW	Reset	Description
[31.:16]	Rsvd2	R	0000	Reserved.
[15]	Rsvd1	R	0	Reserved.
[14.:8]	CC	RW	00	CC: Category Code.
[7]	L	RW	0	L: Generation Level.
[6]	PRO	RW	0	PRO: Professional.
[5]	AUDIO	RW	0	/AUDIO: Non-Audio.
[4]	COPY	RW	0	COPY: Copyright.
[3]	PRE	RW	0	PRE: Preemphasis.
[2]	VCFG	RW	0	VCFG: Validity Config.
[1]	V	RW	0	V: Validity.
[0]	DigEn	RW	0	Digital enable: 1 = converter enabled, 0 = converter disable.

5.30.7. SPDIFOut0 OutAmpCap

	Verb ID	Payload	Response
Get	F00	12	See bitfield table.

5.30.7.1. SPDIFOut0 OutAmpCap

Bit	Bitfield Name	RW	Reset	Description
[31]	Mute	R	1	Mute support: 1 = yes, 0 = no.
[30.:23]	Rsvd3	R	00	Reserved.
[22.:16]	StepSize	R	17	Size of each step in the gain range: 0 to 127 = .25dB to 32dB, in .25dB steps.
[15]	Rsvd2	R	0	Reserved.
[14.:8]	NumSteps	R	00	Number of gains steps (number of possible settings - 1).
[7]	Rsvd1	R	0	Reserved.
[6.:0]	Offset	R	03	Indicates which step is 0dB

5.30.8. SPDIFOut0 OutAmpLeft

	Verb ID	Payload	Response
Get	BA0	00	See bitfield table.

5.30.8.1. SPDIFOut0 OutAmpLeft

Bit	Bitfield Name	RW	Reset	Description
[31.:8]	Rsvd2	R	000000	Reserved.
[7]	Mute	RW	0	Amp mute: 1 = muted, 0 = not muted.
[6.:0]	Rsvd1	R	00	Reserved.

5.30.9. SPDIFOut0 OutAmpRight

	Verb ID	Payload	Response
Get	B80	00	See bitfield table.

5.30.9.1. SPDIFOut0 OutAmpRight

Bit	Bitfield Name	RW	Reset	Description
[31..8]	Rsvd2	R	000000	Reserved.
[7]	Mute	RW	0	Amp mute: 1 = muted, 0 = not muted.
[6..0]	Rsvd1	R	00	Reserved.

5.31. SPDIFOut1 Node (NID = 26)**5.31.1. SPDIFOut1 WCap**

	Verb ID	Payload	Response
Get	F00	09	See bitfield table.

5.31.1.1. SPDIFOut1 WCap

Bit	Bitfield Name	RW	Reset	Description
[31..24]	Rsvd2	R	00	Reserved.
[23..20]	Type	R	0	Widget type: 0h = Out Converter; 1h = In Converter; 2h = Summing (Mixer); 3h = Selector (Mux); 4h = Pin Complex; 5h = Power; 6h = Volume Knob; 7h = Beep Generator; 8h-Eh = Reserved; Fh = Vendor Defined
[19..16]	Delay	R	4	Number of sample delays through widget.
[15..12]	Rsvd1	R	0	Reserved.
[11]	SwapCap	R	0	Left/right swap support: 1 = yes, 0 = no.
[10]	PwrCntrl	R	0	Power state support: 1 = yes, 0 = no.

5.31.1.1. SPDIFOut1 WCap

Bit	Bitfield Name	RW	Reset	Description
[9]	Dig	R	1	Digital stream support: 1 = yes (digital), 0 = no (analog).
[8]	ConnList	R	0	Connection list present: 1 = yes, 0 = no.
[7]	UnSolCap	R	0	Unsolicited response support: 1 = yes, 0 = no.
[6]	ProcWidget	R	0	Processing state support: 1 = yes, 0 = no.
[5]	Stripe	R	0	Striping support: 1 = yes, 0 = no.
[4]	FormatOvrd	R	1	Stream format override: 1 = yes, 0 = no.
[3]	AmpParOvrd	R	1	Amplifier capabilities override: 1 = yes, no.
[2]	OutAmpPrsnt	R	1	Output amp present: 1 = yes, 0 = no.
[1]	InAmpPrsnt	R	0	Input amp present: 1 = yes, 0 = no.
[0]	Stereo	R	1	Stereo stream support: 1 = yes (stereo), 0 = no (mono).

5.31.2. SPDIFOut1 PCMCap

	Verb ID	Payload	Response
Get	F00	0A	See bitfield table.

5.31.2.1. SPDIFOut1 PCMCap

Bit	Bitfield Name	RW	Reset	Description
[31..21]	Rsvd2	R	000	Reserved.
[20]	B32	R	0	32 bit audio format support: 1 = yes, 0 = no.
[19]	B24	R	1	24 bit audio format support: 1 = yes, 0 = no.
[18]	B20	R	1	20 bit audio format support: 1 = yes, 0 = no.

5.31.2.1. SPDIFOut1 PCMCap

Bit	Bitfield Name	RW	Reset	Description
[17]	B16	R	1	16 bit audio format support: 1 = yes, 0 = no.
[16]	B8	R	0	8 bit audio format support: 1 = yes, 0 = no.
[15.:12]	Rsvd1	R	0	Reserved.
[11]	R12	R	0	384kHz rate support: 1 = yes, 0 = no.
[10]	R11	R	1	192kHz rate support: 1 = yes, 0 = no.
[9]	R10	R	1	176.4kHz rate support: 1 = yes, 0 = no.
[8]	R9	R	1	96kHz rate support: 1 = yes, 0 = no.
[7]	R8	R	1	88.2kHz rate support: 1 = yes, 0 = no.
[6]	R7	R	1	48kHz rate support: 1 = yes, 0 = no.
[5]	R6	R	1	44.1kHz rate support: 1 = yes, 0 = no.
[4]	R5	R	0	32kHz rate support: 1 = yes, 0 = no.
[3]	R4	R	0	22.05kHz rate support: 1 = yes, 0 = no.
[2]	R3	R	0	16kHz rate support: 1 = yes, 0 = no.
[1]	R2	R	0	11.025kHz rate support: 1 = yes, 0 = no.
[0]	R1	R	0	8kHz rate support: 1 = yes, 0 = no.

5.31.3. SPDIFOut1 StreamCap

	Verb ID	Payload	Response
Get	F00	0B	See bitfield table.

5.31.3.1. SPDIFOut1 StreamCap

Bit	Bitfield Name	RW	Reset	Description
[31.:3]	Rsvd	R	00000000	Reserved.
[2]	AC3	R	1	AC-3 formatted data support: 1 = yes, 0 = no.

5.31.3.1. *SPDIFOut1 StreamCap*

Bit	Bitfield Name	RW	Reset	Description
[1]	Float32	R	0	Float32 formatted data support: 1 = yes, 0 = no.
[0]	PCM	R	1	PCM-formatted data support: 1 = yes, 0 = no.

5.31.4. *SPDIFOut1 Cnvtr*

	Verb ID	Payload	Response
Get	A00	00	See bitfield table.

5.31.4.1. *SPDIFOut1 Cnvtr*

Bit	Bitfield Name	RW	Reset	Description
[31.:16]	Rsvd2	R	0000	Reserved.
[15]	FrmtNonPCM	RW	0	Stream type: 1 = Non-PCM, 0 = PCM.
[14]	FrmtSmplRate	RW	0	Sample base rate: 1 = 44.1kHz, 0 = 48kHz.
[13.:11]	SmplRateMultp	RW	0	Sample base rate multiple: 000b= x1 (48kHz/44.1kHz or less); 001b= x2 (96kHz/88.2kHz/32kHz); 010b= x3 (144kHz); 011b= x4 (192kHz/176.4kHz); 100b-111b Reserved
[10.:8]	SmplRateDiv	RW	0	Sample base rate divider: 000b= Divide by 1 (48kHz/44.1kHz); 001b= Divide by 2 (24kHz/20.05kHz); 010b= Divide by 3 (16kHz/32kHz); 011b= Divide by 4 (11.025kHz); 100b= Divide by 5 (9.6kHz); 101b= Divide by 6 (8kHz); 110b= Divide by 7; 111b= Divide by 8 (6kHz)
[7]	Rsvd1	R	0	Reserved.

5.31.4.1. *SPDIFOut1 Cnvtr*

Bit	Bitfield Name	RW	Reset	Description
[6.:4]	BitsPerSmpl	RW	3	Bits per sample: 000b= 8 bits; 001b= 16 bits; 010b= 20 bits; 011b= 24 bits; 100b= 32 bits; 101b-111b= Reserved
[3.:0]	NmbrChan	RW	1	Total number of channels in the stream assigned to this converter: 0000b-1111b= 1-16 channels.

5.31.5. *SPDIFOut1 CnvtrID*

	Verb ID	Payload	Response
Get	F06	00	See bitfield table.

5.31.5.1. *SPDIFOut1 CnvtrID*

Bit	Bitfield Name	RW	Reset	Description
[31.:8]	Rsvd	R	000000	Reserved.
[7.:4]	Strm	RW	0	Stream ID: 0h = Converter "off", 1h-Fh = valid IDs.
[3.:0]	Ch	RW	0	Channel assignment ("Ch" and "Ch+1" assigned as a pair, for a stereo converter).

5.31.6. *SPDIFOut1 DigCnvtr*

	Verb ID	Payload	Response
Get	F0D	00	See bitfield table.

5.31.6.1. *SPDIFOut1 DigCnvtr*

Bit	Bitfield Name	RW	Reset	Description
[31.:16]	Rsvd2	R	0000	Reserved.
[15]	Rsvd1	R	0	Reserved.

5.31.6.1. SPDIFOut1 DigCnvtr

Bit	Bitfield Name	RW	Reset	Description
[14.:8]	CC	RW	00	CC: Category Code.
[7]	L	RW	0	L: Generation Level.
[6]	PRO	RW	0	PRO: Professional.
[5]	AUDIO	RW	0	/AUDIO: Non-Audio.
[4]	COPY	RW	0	COPY: Copyright.
[3]	PRE	RW	0	PRE: Preemphasis.
[2]	VCFG	RW	0	VCFG: Validity Config.
[1]	V	RW	0	V: Validity.
[0]	DigEn	RW	0	Digital enable: 1 = converter enabled, 0 = converter disable.

5.31.7. SPDIFOut1 OutAmpCap

	Verb ID	Payload	Response
Get	F00	12	See bitfield table.

5.31.7.1. SPDIFOut1 OutAmpCap

Bit	Bitfield Name	RW	Reset	Description
[31]	Mute	R	1	Mute support: 1 = yes, 0 = no.
[30.:23]	Rsvd3	R	00	Reserved.
[22.:16]	StepSize	R	00	Size of each step in the gain range: 0 to 127 = .25dB to 32dB, in .25dB steps.
[15]	Rsvd2	R	0	Reserved.
[14.:8]	NumSteps	R	00	Number of gains steps (number of possible settings - 1).
[7]	Rsvd1	R	0	Reserved.
[6.:0]	Offset	R	00	Indicates which step is 0dB

5.31.8. SPDIFOut1 OutAmpLeft

	Verb ID	Payload	Response
Get	BA0	00	See bitfield table.

5.31.8.1. SPDIFOut1 OutAmpLeft

Bit	Bitfield Name	RW	Reset	Description
[31..8]	Rsvd2	R	000000	Reserved.
[7]	Mute	RW	0	Amp mute: 1 = muted, 0 = not muted.
[6.:0]	Rsvd1	R	00	Reserved.

5.31.9. SPDIFOut1 OutAmpRight

	Verb ID	Payload	Response
Get	B80	00	See bitfield table.

5.31.9.1. SPDIFOut1 OutAmpRight

Bit	Bitfield Name	RW	Reset	Description
[31..8]	Rsvd2	R	000000	Reserved.
[7]	Mute	RW	0	Amp mute: 1 = muted, 0 = not muted.
[6.:0]	Rsvd1	R	00	Reserved.

5.32. SPDIFIn Node (NID = 27)**5.32.1. SPDIFOut1 WCap**

	Verb ID	Payload	Response
Get	F00	09	See bitfield table.

5.32.1.1. SPDIFInWCap

Bit	Bitfield Name	RW	Reset	Description
[31.:24]	Rsvd2	R	00	Reserved.
[23.:20]	Type	R	1	Widget type: 0h = Out Converter; 1h = In Converter; 2h = Summing (Mixer); 3h = Selector (Mux); 4h = Pin Complex; 5h = Power; 6h = Volume Knob; 7h = Beep Generator; 8h-Eh = Reserved; Fh = Vendor Defined
[19.:16]	Delay	R	4	Number of sample delays through widget.
[15.:12]	Rsvd1	R	0	Reserved.
[11]	SwapCap	R	0	Left/right swap support: 1 = yes, 0 = no.
[10]	PwrCntrl	R	0	Power state support: 1 = yes, 0 = no.
[9]	Dig	R	1	Digital stream support: 1 = yes (digital), 0 = no (analog).
[8]	ConnList	R	1	Connection list present: 1 = yes, 0 = no.
[7]	UnSolCap	R	0	Unsolicited response support: 1 = yes, 0 = no.
[6]	ProcWidget	R	0	Processing state support: 1 = yes, 0 = no.
[5]	Stripe	R	0	Striping support: 1 = yes, 0 = no.
[4]	FormatOvrd	R	1	Stream format override: 1 = yes, 0 = no.
[3]	AmpParOvrd	R	1	Amplifier capabilities override: 1 = yes, no.
[2]	OutAmpPrsnt	R	0	Output amp present: 1 = yes, 0 = no.
[1]	InAmpPrsnt	R	1	Input amp present: 1 = yes, 0 = no.
[0]	Stereo	R	1	Stereo stream support: 1 = yes (stereo), 0 = no (mono).

5.32.2. SPDIFInCnvtr

	Verb ID	Payload	Response
Get	A00	00	See bitfield table.

5.32.2.1. SPFIDIn Cnvtr

Bit	Bitfield Name	RW	Reset	Description
[31..16]	Rsvd2	R	0000	Reserved.
[15]	FrmtNonPCM	R	0	Stream type: 1 = Non-PCM 0 = PCM.
[14]	FrmtSmplRate	RW	0	Sample base rate: 1 = 44.1kHz 0 = 48kHz.
[13..11]	SmplRateMultp	RW	0	Sample base rate multiple: 000b= x1 (48kHz/44.1kHz or less); 001b= x2 (96kHz/88.2kHz/32kHz); 010b= x3 (144kHz); 011b= x4 (192kHz/176.4kHz); 100b-111b Reserved
[10..8]	SmplRateDiv	RW	0	Sample base rate divider: 000b= Divide by 1 (48kHz/44.1kHz); 001b= Divide by 2 (24kHz/20.05kHz); 010b= Divide by 3 (16kHz/32kHz); 011b= Divide by 4 (11.025kHz); 100b= Divide by 5 (9.6kHz); 101b= Divide by 6 (8kHz); 110b= Divide by 7; 111b= Divide by 8 (6kHz)
[7]	Rsvd1	R	0	Reserved.
[6..4]	BitsPerSmpl	RW	3	Bits per sample: 000b= 8 bits; 001b= 16 bits; 010b= 20 bits; 011b= 24 bits; 100b= 32 bits; 101b-111b= Reserved
[3..0]	NmbrChan	RW	1	Total number of channels in the stream assigned to this converter: 0000b-1111b= 1-16 channels.

5.32.3. SPDIFIn PCMCap

	Verb ID	Payload	Response
Get	F00	0A	See bitfield table.

5.32.3.1. SPDIFIn PCMCap

Bit	Bitfield Name	RW	Reset	Description
[31..:21]	Rsvd2	R	000	Reserved.
[20]	B32	R	0	32 bit audio format support: 1 = yes, 0 = no.
[19]	B24	R	1	24 bit audio format support: 1 = yes, 0 = no.
[18]	B20	R	1	20 bit audio format support: 1 = yes, 0 = no.
[17]	B16	R	1	16 bit audio format support: 1 = yes, 0 = no.
[16]	B8	R	0	8 bit audio format support: 1 = yes, 0 = no.
[15..:12]	Rsvd1	R	0	Reserved.
[11]	R12	R	0	384kHz rate support: 1 = yes, 0 = no.
[10]	R11	R	0	192kHz rate support: 1 = yes, 0 = no.
[9]	R10	R	0	176.4kHz rate support: 1 = yes, 0 = no.
[8]	R9	R	1	96kHz rate support: 1 = yes, 0 = no.
[7]	R8	R	0	88.2kHz rate support: 1 = yes, 0 = no.
[6]	R7	R	1	48kHz rate support: 1 = yes, 0 = no.
[5]	R6	R	1	44.1kHz rate support: 1 = yes, 0 = no.
[4]	R5	R	0	32kHz rate support: 1 = yes, 0 = no.
[3]	R4	R	0	22.05kHz rate support: 1 = yes, 0 = no.
[2]	R3	R	0	16kHz rate support: 1 = yes, 0 = no.
[1]	R2	R	0	11.025kHz rate support: 1 = yes, 0 = no.
[0]	R1	R	0	8kHz rate support: 1 = yes, 0 = no.

5.32.4. SPDIFIn StreamCap

	Verb ID	Payload	Response
Get	F00	0B	See bitfield table.

5.32.4.1. SPDIFIn StreamCap

Bit	Bitfield Name	RW	Reset	Description
[31..3]	Rsvd	R	00000000	Reserved.
[2]	AC3	R	1	AC-3 formatted data support: 1 = yes, 0 = no.
[1]	Float32	R	0	Float32 formatted data support: 1 = yes, 0 = no.
[0]	PCM	R	1	PCM-formatted data support: 1 = yes, 0 = no.

5.32.5. SPDIFIn ConLst

	Verb ID	Payload	Response
Get	F00	0E	See bitfield table.

5.32.5.1. SPDIFIn ConLst

Bit	Bitfield Name	RW	Reset	Description
[31..8]	Rsvd	R	000000	Reserved.
[7]	LForm	R	0	Connection list format: 1 = long-form (15-bit) NID entries 0 = short-form (7-bit) NID entries.
[6..0]	ConL	R	01	Number of NID entries in connection list.

5.32.6. SPDIFIn ConLstEntry0

	Verb ID	Payload	Response
Get	F02	00	See bitfield table.

5.32.6.1. ADC0 ConLstEntry0

Bit	Bitfield Name	RW	Reset	Description
[31.:24]	ConL3	R	00	Unused list entry.
[23.:16]	ConL2	R	00	Unused list entry.
[15.:8]	ConL1	R	00	Unused list entry.
[7.:0]	ConL0	R	24	Dig2Pin pin widget (0x24).

5.32.7. SPDIFIn CnvtrID

	Verb ID	Payload	Response
Get	F06	00	See bitfield table.

5.32.7.1. SPDIFIn CnvtrID

Bit	Bitfield Name	RW	Reset	Description
[31.:8]	Rsvd	R	000000	Reserved.
[7.:4]	Strm	RW	0	Stream ID: 0h = Converter "off" 1h-Fh = valid IDs.
[3.:0]	Ch	RW	0	Channel assignment ("Ch" and "Ch+1" assigned as a pair for a stereo converter).

5.32.8. SPDIFIn DigCnvtr

	Verb ID	Payload	Response
Get	F0D	00	See bitfield table.

5.32.8.1. SPDIFIn DigCnvtr

Bit	Bitfield Name	RW	Reset	Description
[31..16]	Rsvd2	R	0000	Reserved.
[15]	Rsvd1	R	0	Reserved.
[14..8]	CC	RW	00	CC: Category Code.
[7]	L	RW	0	L: Generation Level.
[6]	PRO	RW	0	PRO: Professional.
[5]	AUDIO	RW	0	/AUDIO: Non-Audio.
[4]	COPY	RW	0	COPY: Copyright.
[3]	PRE	RW	0	PRE: Preemphasis.
[2]	VCFG	RW	0	VCFG: Validity Config.
[1]	V	RW	0	V: Validity.
[0]	DigEn	RW	0	Digital enable: 1 = converter enabled, 0 = converter disable.

5.32.9. SPDIFIn OutAmpCap

	Verb ID	Payload	Response
Get	F00	12	See bitfield table.

5.32.9.1. SPDIFIn OutAmpCap

Bit	Bitfield Name	RW	Reset	Description
[31]	Mute	R	1	Mute support: 1 = yes, 0 = no.
[30..23]	Rsvd3	R	00	Reserved.
[22..16]	StepSize	R	00	Size of each step in the gain range: 0 to 127 = .25dB to 32dB, in .25dB steps.
[15]	Rsvd2	R	0	Reserved.
[14..8]	NumSteps	R	00	Number of gains steps (number of possible settings - 1).

5.32.9.1. *SPDIFIn OutAmpCap*

Bit	Bitfield Name	RW	Reset	Description
[7]	Rsvd1	R	0	Reserved.
[6.:0]	Offset	R	00	Indicates which step is 0dB

5.32.10. *SPDIFIn InAmpLeft*

	Verb ID	Payload	Response
Get	B20	00	See bitfield table.

5.32.10.1. *SPDIFOut1 OutAmpLeft*

Bit	Bitfield Name	RW	Reset	Description
[31.:8]	Rsvd2	R	000000	Reserved.
[7]	Mute	RW	0	Amp mute: 1 = muted, 0 = not muted.
[6.:0]	Rsvd1	R	00	Reserved.

5.32.11. *SPDIFIn InAmpRight*

	Verb ID	Payload	Response
Get	B00	00	See bitfield table.

5.32.11.1. *SPDIFOut1 OutAmpRight*

Bit	Bitfield Name	RW	Reset	Description
[31.:8]	Rsvd2	R	000000	Reserved.
[7]	Mute	RW	0	Amp mute: 1 = muted, 0 = not muted.
[6.:0]	Rsvd1	R	00	Reserved.

5.32.12. SPDIFIn VS

	Verb ID	Payload	Response
Get	FE0	00	See bitfield table.

5.32.12.1. SPDIFIn VS

Bit	Bitfield Name	RW	Reset	Description
[31..2]	Rsvd	R	0000000	Reserved.
[1]	RoundDis	RW	0	SPDIF Input rounding disable: 0 = rounding is enabled, 1 = rounding is disabled
[0]	LoLvISel	RW	0	SPDIF Input level select: 0 = standard level, 1 = low level (input buffer enabled).

5.32.13. SPDIFIn Status

	Verb ID	Payload	Response
Get	FE0	80	See bitfield table.

5.32.13.1. SPDIFIn Status

Bit	Bitfield Name	RW	Reset	Description
[31..29]	RcvSmplRate	R	7	Received Sample Rate: 000b = 44.1kHz 001b = 48kHz 010b = 88.2kHz 011b = 96kHz 100b = 176.4kHz 101b = 192kHz 11Xb = Invalid Rate
[28..26]	Rsvd2	R	0	Reserved

92HD73E

Ten Channel HD Audio Codec

5.32.13.1. SPDIFIn Status

Bit	Bitfield Name	RW	Reset	Description
[25.:22]	OrigFS	R	0	Original Sample Rate (per IEC60958-3 spec): 0000b = Original sampling frequency not indicated 0001b = 192kHz 0010b = 12kHz 0011b = 176.4kHz 0100b = Reserved 0101b = 96kHz 0110b = 8kHz 0111b = 88.2kHz 1000b = 16kHz 1001b = 24kHz 1010b = 11.025kHz 1011b = 22.05kHz 1100b = 32kHz 1101b = 48kHz 1110b = Reserved 1111b = 44.1kHz
[21.:20]	CA	R	0	Clock Accuracy (per IEC60958-3 spec): 00b = Level II 01b = Level I 10b = Level III 11b = Reserved
[19.:16]	FS	R	0	Sample Rate (per IEC60958-3 spec): 0000b = 44.1kHz 0001b = Original sampling frequency not indicated 0010b = 48kHz 0011b = 32kHz 0100b = 22.05kHz 0101b = Reserved 0110b = 24kHz 0111b = Reserved 1000b = 88.2kHz 1001b = Reserved 1010b = 96kHz 1011b = Reserved 1100b = 176.4kHz 1101b = Reserved 1110b = 192kHz 1111b = Reserved

5.32.13.1. SPDIFIn Status

Bit	Bitfield Name	RW	Reset	Description
[15.:12]	CN	R	0	Channel Number (per IEC60958-3 spec): 0000b = Do not take into account 0001b = Channel 1 (Left channel for stereo channel format) 0010b = Channel 2 (Right channel for stereo channel format) 0011b-1111b = Channel 3-15
[11.:9]	SmpIWrdL	R	0	Sample Word Length (per IEC60958-3 spec): 000b = Word length not indicated 001b = Max length - 4 010b = Max length - 2 011b = Reserved 100b = Max length - 1 101b = Max length - 0 110b = Max length - 3 111b = Reserved
[8]	MaxWrdL	R	0	Max Word Length (per IEC60958-3 spec): 0 = 20 bits, 1 = 24 bits.
[7]	NoBlkChk	RW	0	Disable Sample Block Checking
[6.:5]	Rsvd	R	0	Reserved
[4.:3]	ParityLimit	RW	0	SPDIFIn Parity Limit: 00b = 4 Parity errors 01b = 3 Parity errors 10b = 2 Parity errors 11b = 1 Parity error
[2]	SPRun	R	0	SPDIFIn Running 0 = no signal on SPDIFIn Pin, 1 = Signal on SPDIFIn pin.
[1]	SiPerr	RW	0	SPDIFIn Parity Error: 0 = No error detected, 1 = Error detected (write 0 to clear).
[0]	CopyInv	RW	0	Copyright Invert: 0 = Do not invert COPY bit, 1 = Invert COPY bit.

5.33. InPort0Mux Node (NID = 28)

5.33.1. InPort0Mux WCap

	Verb ID	Payload	Response
Get	F00	09	See bitfield table.

5.33.1.1. InPort0Mux WCap

Bit	Bitfield Name	RW	Reset	Description
[31..24]	Rsvd2	R	00	Reserved.
[23..20]	Type	R	3	Widget type: 0h = Out Converter; 1h = In Converter; 2h = Summing (Mixer); 3h = Selector (Mux); 4h = Pin Complex; 5h = Power; 6h = Volume Knob; 7h = Beep Generator; 8h-Eh = Reserved; Fh = Vendor Defined
[19..16]	Delay	R	0	Number of sample delays through widget.
[15..12]	Rsvd1	R	0	Reserved.
[11]	SwapCap	R	0	Left/right swap support: 1 = yes 0 = no.
[10]	PwrCntrl	R	0	Power state support: 1 = yes 0 = no.
[9]	Dig	R	0	Digital stream support: 1 = yes (digital) 0 = no (analog).
[8]	ConnList	R	1	Connection list present: 1 = yes 0 = no.
[7]	UnSolCap	R	0	Unsolicited response support: 1 = yes 0 = no.
[6]	ProcWidget	R	0	Processing state support: 1 = yes 0 = no.
[5]	Stripe	R	0	Striping support: 1 = yes 0 = no.
[4]	FormatOvrd	R	0	Stream format override: 1 = yes 0 = no.
[3]	AmpParOvrd	R	0	Amplifier capabilities override: 1 = yes no.
[2]	OutAmpPrsnt	R	0	Output amp present: 1 = yes 0 = no.

5.33.1.1. *InPort0Mux WCap*

Bit	Bitfield Name	RW	Reset	Description
[1]	InAmpPrsnt	R	0	Input amp present: 1 = yes 0 = no.
[0]	Stereo	R	1	Stereo stream support: 1 = yes (stereo) 0 = no (mono).

5.33.2. *InPort0Mux ConLst*

	Verb ID	Payload	Response
Get	F00	0E	See bitfield table.

5.33.2.1. *InPort0Mux ConLst*

Bit	Bitfield Name	RW	Reset	Description
[31..8]	Rsvd	R	000000	Reserved.
[7]	LForm	R	0	Connection list format: 1 = long-form (15-bit) NID entries 0 = short-form (7-bit) NID entries.
[6..0]	ConL	R	04	Number of NID entries in connection list.

5.33.3. *InPort0Mux ConLstEntry0*

	Verb ID	Payload	Response
Get	F02	00	See bitfield table.

5.33.3.1. *InPort0Mux ConLstEntry0*

Bit	Bitfield Name	RW	Reset	Description
[31..24]	ConL3	R	0F	Port F Pin widget (0x0F).
[23..16]	ConL2	R	0D	Port D Pin widget (0x0D)
[15..8]	ConL1	R	0B	Port B Pin widget (0x0B)
[7..0]	ConL0	R	0A	Port A Pin widget (0x0A)

5.33.4. InPort0Mux ConSelectCtrl

	Verb ID	Payload	Response
Get	F01	00	See bitfield table.

5.33.4.1. InPort0Mux ConSelectCtrl

Bit	Bitfield Name	RW	Reset	Description
[31..2]	Rsvd	R	00000000	Reserved.
[1..0]	Index	RW	0	Connection select control index.

5.34. InPort1Mux Node (NID = 29)**5.34.1. InPort1Mux WCap**

	Verb ID	Payload	Response
Get	F00	09	See bitfield table.

5.34.1.1. InPort1Mux WCap

Bit	Bitfield Name	RW	Reset	Description
[31..24]	Rsvd2	R	00	Reserved.
[23..20]	Type	R	3	Widget type: 0h = Out Converter; 1h = In Converter; 2h = Summing (Mixer); 3h = Selector (Mux); 4h = Pin Complex; 5h = Power; 6h = Volume Knob; 7h = Beep Generator; 8h-Eh = Reserved; Fh = Vendor Defined
[19..16]	Delay	R	0	Number of sample delays through widget.
[15..12]	Rsvd1	R	0	Reserved.
[11]	SwapCap	R	0	Left/right swap support: 1 = yes 0 = no.
[10]	PwrCntrl	R	0	Power state support: 1 = yes 0 = no.
[9]	Dig	R	0	Digital stream support: 1 = yes (digital) 0 = no (analog).

5.34.1.1. *InPort1Mux WCap*

Bit	Bitfield Name	RW	Reset	Description
[8]	ConnList	R	1	Connection list present: 1 = yes 0 = no.
[7]	UnSolCap	R	0	Unsolicited response support: 1 = yes 0 = no.
[6]	ProcWidget	R	0	Processing state support: 1 = yes 0 = no.
[5]	Stripe	R	0	Striping support: 1 = yes 0 = no.
[4]	FormatOvrd	R	0	Stream format override: 1 = yes 0 = no.
[3]	AmpParOvrd	R	0	Amplifier capabilities override: 1 = yes no.
[2]	OutAmpPrsnt	R	0	Output amp present: 1 = yes 0 = no.
[1]	InAmpPrsnt	R	0	Input amp present: 1 = yes 0 = no.
[0]	Stereo	R	1	Stereo stream support: 1 = yes (stereo) 0 = no (mono).

5.34.2. *InPort1Mux ConLst*

	Verb ID	Payload	Response
Get	F00	0E	See bitfield table.

5.34.2.1. *InPort1Mux ConLst*

Bit	Bitfield Name	RW	Reset	Description
[31.:8]	Rsvd	R	000000	Reserved.
[7]	LForm	R	0	Connection list format: 1 = long-form (15-bit) NID entries 0 = short-form (7-bit) NID entries.
[6.:0]	ConL	R	04	Number of NID entries in connection list.

5.34.3. InPort1Mux ConLstEntry0

	Verb ID	Payload	Response
Get	F02	00	See bitfield table.

5.34.3.1. InPort1Mux ConLstEntry0

Bit	Bitfield Name	RW	Reset	Description
[31.:24]	ConL3	R	11	Port H Pin widget (0x11)
[23.:16]	ConL2	R	10	Port G Pin widget (0x10)
[15.:8]	ConL1	R	0E	Port E Pin widget (0x0E)
[7.:0]	ConL0	R	0A	Port A Pin widget (0x0A)

5.34.4. InPort1Mux ConSelectCtrl

	Verb ID	Payload	Response
Get	F01	00	See bitfield table.

5.34.4.1. InPort1Mux ConSelectCtrl

Bit	Bitfield Name	RW	Reset	Description
[31.:2]	Rsvd	R	00000000	Reserved.
[1.:0]	Index	RW	0	Connection select control index.

5.35. InPort2Mux Node (NID = 2A)**5.35.1. InPort2Mux WCap**

	Verb ID	Payload	Response
Get	F00	09	See bitfield table.

5.35.1.1. *InPort2Mux WCap*

Bit	Bitfield Name	RW	Reset	Description
[31.:24]	Rsvd2	R	00	Reserved.
[23.:20]	Type	R	3	Widget type: 0h = Out Converter; 1h = In Converter; 2h = Summing (Mixer); 3h = Selector (Mux); 4h = Pin Complex; 5h = Power; 6h = Volume Knob; 7h = Beep Generator; 8h-Eh = Reserved; Fh = Vendor Defined
[19.:16]	Delay	R	0	Number of sample delays through widget.
[15.:12]	Rsvd1	R	0	Reserved.
[11]	SwapCap	R	0	Left/right swap support: 1 = yes 0 = no.
[10]	PwrCntrl	R	0	Power state support: 1 = yes 0 = no.
[9]	Dig	R	0	Digital stream support: 1 = yes (digital) 0 = no (analog).
[8]	ConnList	R	1	Connection list present: 1 = yes 0 = no.
[7]	UnSolCap	R	0	Unsolicited response support: 1 = yes 0 = no.
[6]	ProcWidget	R	0	Processing state support: 1 = yes 0 = no.
[5]	Stripe	R	0	Striping support: 1 = yes 0 = no.
[4]	FormatOvrd	R	0	Stream format override: 1 = yes 0 = no.
[3]	AmpParOvrd	R	0	Amplifier capabilities override: 1 = yes no.
[2]	OutAmpPrsnt	R	0	Output amp present: 1 = yes 0 = no.
[1]	InAmpPrsnt	R	0	Input amp present: 1 = yes 0 = no.
[0]	Stereo	R	1	Stereo stream support: 1 = yes (stereo) 0 = no (mono).

5.35.2. InPort2Mux ConLst

	Verb ID	Payload	Response
Get	F00	0E	See bitfield table.

5.35.2.1. InPort2Mux ConLst

Bit	Bitfield Name	RW	Reset	Description
[31..8]	Rsvd	R	000000	Reserved.
[7]	LForm	R	0	Connection list format: 1 = long-form (15-bit) NID entries 0 = short-form (7-bit) NID entries.
[6..0]	ConL	R	04	Number of NID entries in connection list.

5.35.3. InPort2Mux ConLstEntry0

	Verb ID	Payload	Response
Get	F02	00	See bitfield table.

5.35.3.1. InPort2Mux ConLstEntry0

Bit	Bitfield Name	RW	Reset	Description
[31..24]	ConL3	R	11	Port H Pin widget (0x11)
[23..16]	ConL2	R	10	Port G Pin widget (0x10)
[15..8]	ConL1	R	0C	Port C Pin widget (0x0C)
[7..0]	ConL0	R	0B	Port B Pin widget (0x0B)

5.35.4. InPort1Mux ConSelectCtrl

	Verb ID	Payload	Response
Get	F01	00	See bitfield table.

\

5.35.4.1. *InPort1Mux ConSelectCtrl*

Bit	Bitfield Name	RW	Reset	Description
[31..2]	Rsvd	R	00000000	Reserved.
[1..0]	Index	RW	0	Connection select control index.

5.36. InPort3Mux Node (NID = 2B)

5.36.1. *InPort3Mux WCap*

	Verb ID	Payload	Response
Get	F00	09	See bitfield table.

5.36.1.1. *InPort3Mux WCap*

Bit	Bitfield Name	RW	Reset	Description
[31..24]	Rsvd2	R	00	Reserved.
[23..20]	Type	R	3	Widget type: 0h = Out Converter; 1h = In Converter; 2h = Summing (Mixer); 3h = Selector (Mux); 4h = Pin Complex; 5h = Power; 6h = Volume Knob; 7h = Beep Generator; 8h-Eh = Reserved; Fh = Vendor Defined
[19..16]	Delay	R	0	Number of sample delays through widget.
[15..12]	Rsvd1	R	0	Reserved.
[11]	SwapCap	R	0	Left/right swap support: 1 = yes 0 = no.
[10]	PwrCntrl	R	0	Power state support: 1 = yes 0 = no.
[9]	Dig	R	0	Digital stream support: 1 = yes (digital) 0 = no (analog).
[8]	ConnList	R	1	Connection list present: 1 = yes 0 = no.
[7]	UnSolCap	R	0	Unsolicited response support: 1 = yes 0 = no.
[6]	ProcWidget	R	0	Processing state support: 1 = yes 0 = no.

5.36.1.1. *InPort3Mux WCap*

Bit	Bitfield Name	RW	Reset	Description
[5]	Stripe	R	0	Striping support: 1 = yes 0 = no.
[4]	FormatOvrd	R	0	Stream format override: 1 = yes 0 = no.
[3]	AmpParOvrd	R	0	Amplifier capabilities override: 1 = yes no.
[2]	OutAmpPrsnt	R	0	Output amp present: 1 = yes 0 = no.
[1]	InAmpPrsnt	R	0	Input amp present: 1 = yes 0 = no.
[0]	Stereo	R	1	Stereo stream support: 1 = yes (stereo) 0 = no (mono).

5.36.2. *InPort3Mux ConLst*

	Verb ID	Payload	Response
Get	F00	0E	See bitfield table.

5.36.2.1. *InPort3Mux ConLst*

Bit	Bitfield Name	RW	Reset	Description
[31.:8]	Rsvd	R	000000	Reserved.
[7]	LForm	R	0	Connection list format: 1 = long-form (15-bit) NID entries 0 = short-form (7-bit) NID entries.
[6.:0]	ConL	R	04	Number of NID entries in connection list.

5.36.3. *InPort3Mux ConLstEntry0*

	Verb ID	Payload	Response
Get	F02	00	See bitfield table.

5.36.3.1. *InPort3Mux ConLstEntry0*

Bit	Bitfield Name	RW	Reset	Description
[31.:24]	ConL3	R	00	Unused list entry
[23.:16]	ConL2	R	00	Unused list entry
[15]	ConL1Range	R	1	1 = ConL0..ConL1 defines a range of selectable inputs.
[14.:8]	ConL1	R	18	DAC3 (0x18)
[7.:0]	ConL0	R	15	DAC0 (0x15)

5.36.4. *InPort3Mux ConSelectCtrl*

	Verb ID	Payload	Response
Get	F01	00	See bitfield table.

5.36.4.1. *InPort3Mux ConSelectCtrl*

Bit	Bitfield Name	RW	Reset	Description
[31.:2]	Rsvd	R	00000000	Reserved.
[1.:0]	Index	RW	0	Connection select control index.

6. DISCLAIMER

While the information presented herein has been checked for both accuracy and reliability, manufacturer assumes no responsibility for either its use or for the infringement of any patents or other rights of third parties, which would result from its use. No other circuits, patents, or licenses are implied. This product is intended for use in normal commercial applications. Any other applications, such as those requiring extended temperature range, high reliability, or other extraordinary environmental requirements, are not recommended without additional processing by manufacturer. Manufacturer reserves the right to change any circuitry or specifications without notice. Manufacturer does not authorize or warrant any product for use in life support devices or critical medical instruments.

7. PINOUTS

7.1. 48QFP

7.1.1. 48QFP Pin Assignment

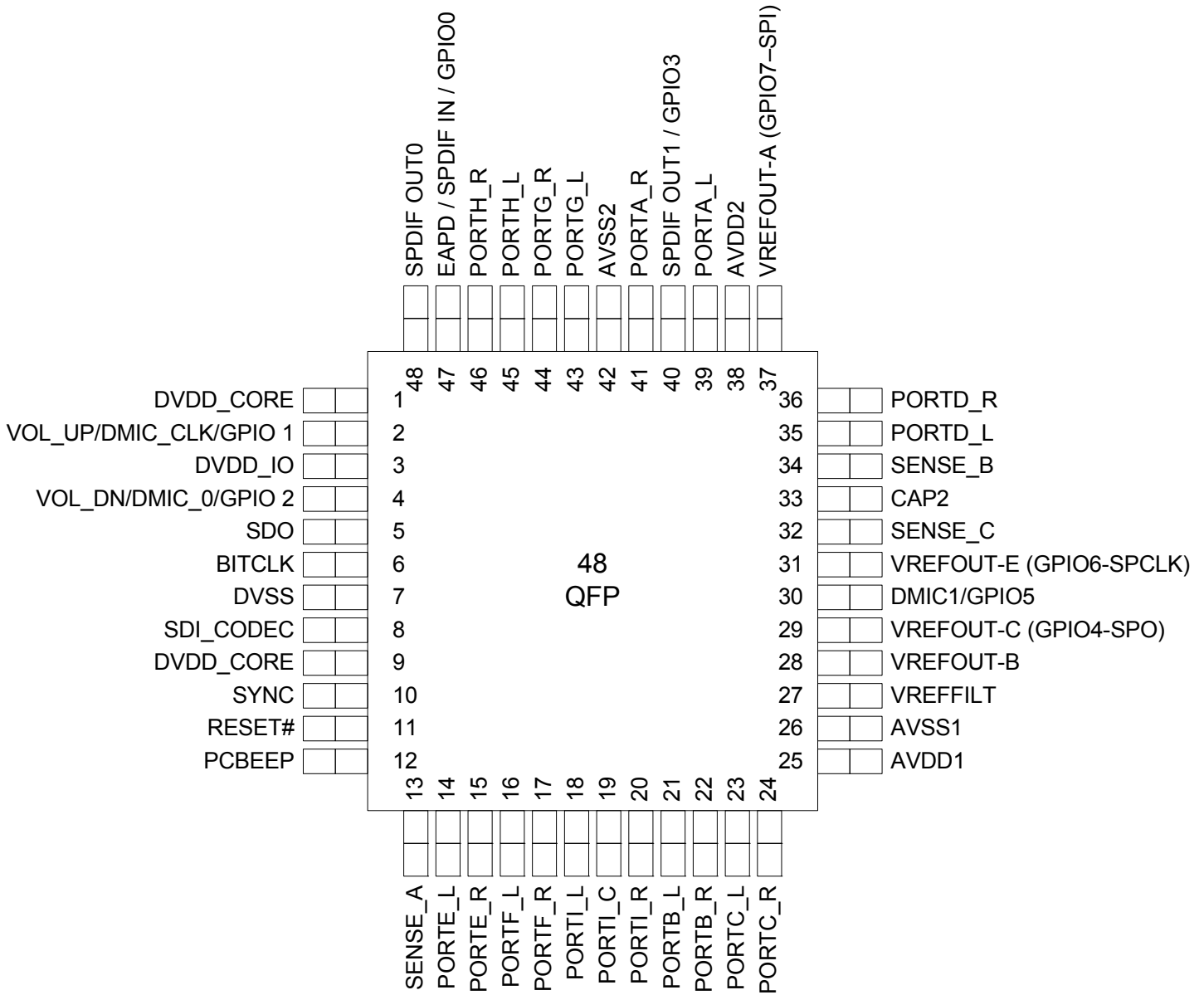

Figure 12. 48QFP Pin Assignment

92HD73E

Ten Channel HD Audio Codec

7.1.2. Pin Tables for 48QFP

Pin Name	Pin Function	I/O	Internal Pull-up Pull-down	48 pin location
DVDD_CORE	Digital Vdd = 3.3V	I(Digital)	None	1
Volume Up/DMIC_CLK/GPIO1	Volume Control <u>OR</u> Digital Mic clock output <u>OR</u> General Purpose I/O	I/O(Digital)	60k Pull-Up with Volume/GPIO or 60k Pull-down with Digital Mic	2
DVDD_IO	Reference Voltage (1.5V or 3.3V)	I(Digital)	None	3
Volume Down/DMIC0/GPIO2	Volume Control <u>OR</u> Digital Mic 01 Input <u>OR</u> General Purpose I/O	I/O(Digital)	60k Pull-Up with Volume/GPIO or 60k Pull-down with Digital Mic	4
SDO	HD Audio Serial Data output (inbound stream)	I/O(Digital)	None	5
BITCLK	HD Audio Bit Clock	I(Digital)	None	6
DVSS	Digital Ground	I(Digital)	None	7
SDI_CODEC	HD Audio Serial Data (outbound stream), audio module	I/O(Digital)	None	8
DVDD_CORE	Digital Vdd= 3.3V	I(Digital)	None	9
SYNC	HD Audio Frame Sync	I(Digital)	None	10
RESET#	HD Audio Reset	I(Digital)	None	11
PCBEEP	Analog PC Beep	I(Analog)	None	12
SENSE_A	Jack insertion detection Ports A,B,C,D	I(Analog)	None	13
PORTE_L	Port E I/O Left	I/O(Analog)	None	14
PORTE_R	Port E I/O Right	I/O(Analog)	None	15
PORTF_L	Port F I/O Left	I/O(Analog)	None	16
PORTF_R	Port F I/O Right	I/O(Analog)	None	17
PORTI_L	Port I Input Left	I (Analog)	None	18
PORTI_Comm	Port I signal Common	I (Analog)	None	19
PORTI_R	Port I Input Right	I (Analog)	None	20
PORTB_L (HP)	Port B I/O Left	I/O(Analog)	None	21
PORTB_R (HP)	Port B I/O Right	I/O(Analog)	None	22
PORTC_L	Port C I/O Left	I/O(Analog)	None	23
PORTC_R	Port C I/O Right	I/O(Analog)	None	24
AVDD1	Analog Vdd=5.0V	I(Analog)	None	25
AVSS1	Analog Ground	I(Analog)	None	26
VREFFILT	Analog Virtual Ground	O(Analog)	None	27
VREFOUT-B	Reference Voltage out drive (intended for mic bias) for Port B	O(Analog)	None	28
VREFOUT-C	Reference Voltage out drive (intended for mic bias) for Port C / Analog GPIO4	I/O(Analog)	None	29

Table 23. 48QFP Pin Table

92HD73E**Ten Channel HD Audio Codec**

Pin Name	Pin Function	I/O	Internal Pull-up Pull-down	48 pin location
DMIC 1 / GPIO5	Second digital mic input or Analog GPIO5	I/O(Analog)	60k Pull-Up with GPIO or 60k Pull-Down with Digital Mic	30
VREFOUT-E / GPIO6	Reference Voltage out drive (intended for mic bias) for Port E / Analog GPIO6	I/O(Analog)	50k Pull-Up with GPIO	31
SENSE C	Jack insertion detection Port I	I(Analog)	None	32
CAP2	ADC reference Cap	O(Analog)	None	33
SENSE B	Jack insertion detection Ports E, F, G, H	I(Analog)	None	34
PORTD_L (HP)	Port D I/O Left	I/O(Analog)	None	35
PORTD_R (HP)	Port D I/O Right	I/O(Analog)	None	36
VREFOUT-A / GPIO7	Reference Voltage out drive (intended for mic bias) for Port A / Analog GPIO7	I/O(Analog)	50k Pull-Up with GPIO	37
AVDD2	Analog Vdd=5.0V	I(Analog)	None	38
PORTA_L (HP)	Port A I/O Left	I/O(Analog)	None	39
SPDIF OUT1	SECOND SPDIF OUT / Analog GPIO3	I/O(Analog)	60K Pull-Down with SPDIF or 60K pull-up with GPIO	40
PORTA_R (HP)	Port A I/O Right	I/O(Analog)	None	41
AVSS2	Analog Ground	I(Analog)	None	42
PORTG_L	Port G I/O Left	I/O(Analog)	None	43
PORTG_R	Port G I/O Right	I/O(Analog)	None	44
PORTH_L	Port H I/O Left	I/O(Analog)	None	45
PORTH_R	Port H I/O Right	I/O(Analog)	None	46
GPIO0/EAPD/SPDIF-IN	General Purpose I/O,EAPD, SPDIF In	I/O(Digital)	60K Pull-Down with SPDIF-IN and EAPD, 60K Pull-Up with GPIO	47
S/SPDIF-OUT0	SPDIF digital output (60K internal pull-down)	O(Digital)	60K Pull-Down	48

Table 23. 48QFP Pin Table

7.2. 40QFN

7.2.1. 40QFN Pin Assignment

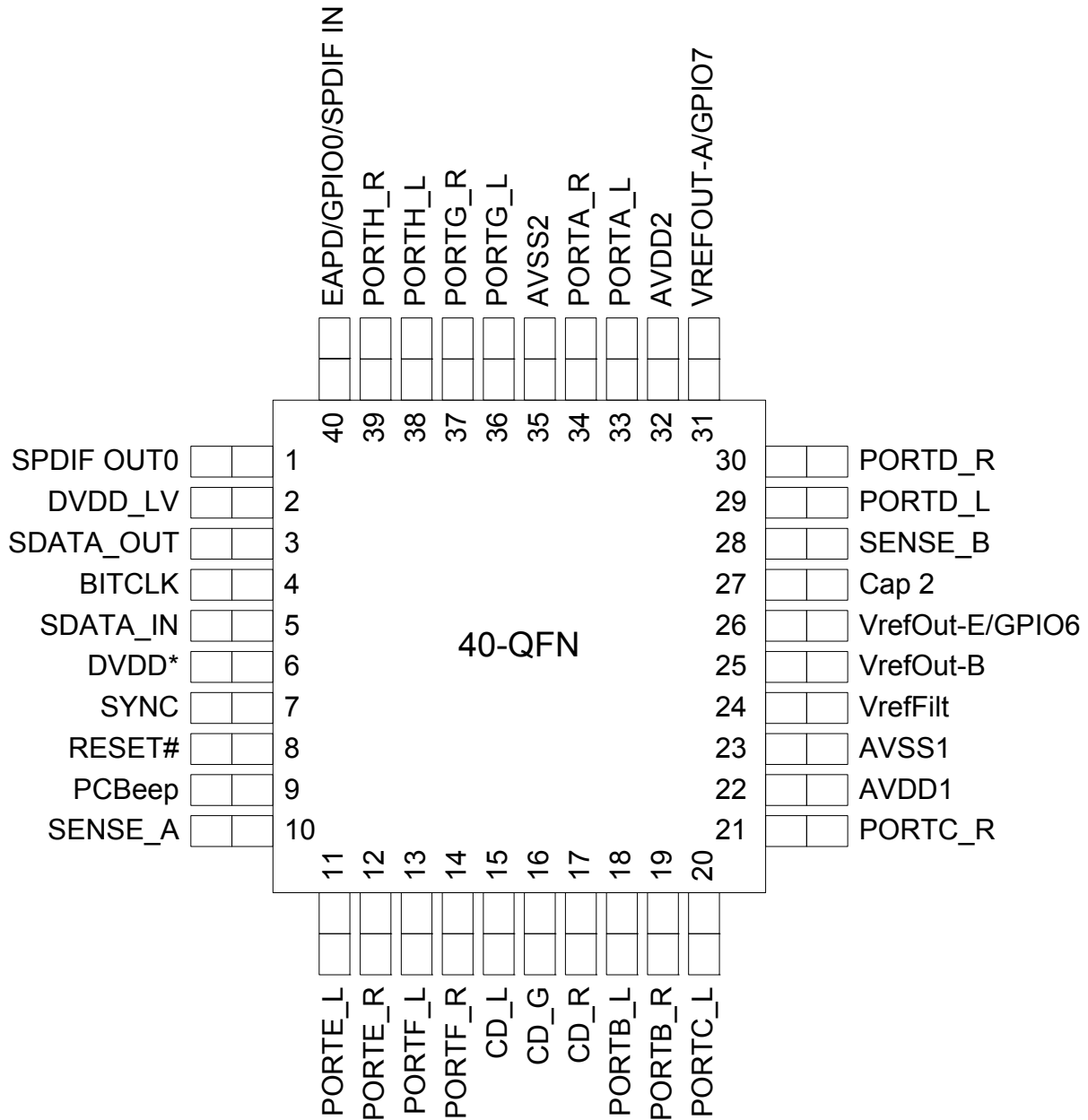

Figure 13. 40QFN Pin Assignment

92HD73E

Ten Channel HD Audio Codec

7.2.2. Pin Tables for 40QFN

Pin Name	Pin Function	I/O	Internal Pull-up Pull-down	40 pin location
S/PDIF-OUT0	SPDIF digital output (60K internal pull-down)	O(Digital)	60K Pull-Down	1
DVDD_LV	DVDD Level	O(Power)	None	2
SDATA_OUT	HD Audio Serial Data output from controller	I(Digital)	None	3
BITCLK	HD Audio Bit Clock	I(Digital)	None	4
SDATA_IN	HD Audio Serial Data Input to controller	I/O(Digital)	None	5
DVDD	Digital Vdd= 3.3V	I(Power)	None	6
SYNC	HD Audio Frame Sync	I(Digital)	None	7
RESET#	HD Audio Reset	I(Digital)	None	8
PCBeep	PC Beep input	I(Analog)	None	9
SENSE_A	Jack insertion detection	I(Analog)	None	10
PORTE_L	Port E Left	I/O(Analog)	None	11
PORTE_R	Port E Right	I/O(Analog)	None	12
PORTF_L	Port F Left	I/O(Analog)	None	13
PORTF_R	Port F Right	I/O(Analog)	None	14
CD Left	CD Left	I(Analog)	None	15
CD Common	CD L/R return	I(Analog)	None	16
CD Right	CD Right	I(Analog)	None	17
PORTB_L (HP)	Port B Output Left	I/O(Analog)	None	18
PORTB_R (HP)	Port B Output Right	I/O(Analog)	None	19
PORTC_L	Port C Left	I/O(Analog)	None	20
PORTC_R	Port C Right	I/O(Analog)	None	21
AVDD1	Analog Vdd=5.0V or 3.3V	I(Analog)	None	22
AVSS1	Analog Ground	I(Analog)	None	23
VREFFILT	Analog Virtual Ground	O(Analog)	None	24
VREFOUT-B	Reference Voltage out drive (intended for mic bias)	O(Analog)	None	25
VREFOUT-E / GPIO2	Reference Voltage out drive (intended for mic bias) or General Purpose I/O	O(Analog)	None	26
CAP 2	ADC reference bypass capacitor	O(Analog)	None	27
SENSE_B	Jack insertion detection	I(Analog)	None	28
PORTD_L (HP)	Port D Output Left	I/O(Analog)	None	29
PORTD_R (HP)	Port D Output Right	I/O(Analog)	None	30
VREFOUT-E / GPIO7	Reference Voltage out drive (intended for mic bias) or General Purpose I/O	O(Analog)	None	31
AVDD2	Analog Supply for VREG	I(Power)	None	32
PORTA_L (HP)	Port A Output Left	I/O(Analog)	None	33
PORTA_R (HP)	Port A Output Right	I/O(Analog)	None	34

Table 24. 40QFN Pin Table

92HD73E

Ten Channel HD Audio Codec

Pin Name	Pin Function	I/O	Internal Pull-up Pull-down	40 pin location
AVSS	Analog Ground	I(Power)	None	35
PORTG_L	Port G Left	I/O(Analog)	None	36
PORTG_R	Port G Right	I/O(Analog)	None	37
PORTH_L	Port H Left	I/O(Analog)	None	38
PORTH_R	Port H Right	I/O(Analog)	None	39
EAPD/SPDIF_IN/GPIO0	EAPD, SPDIF Input, GPIO0	I/O(Digital)	60K Pull-Up/Down	40
The DAP pad must be connected to DVSS on the 40-pin package				

Table 24. 40QFN Pin Table

8. PACKAGE OUTLINE AND PACKAGE DIMENSIONS

Package dimensions are kept current with JEDEC Publication No. 95

8.1. 48QFP Package

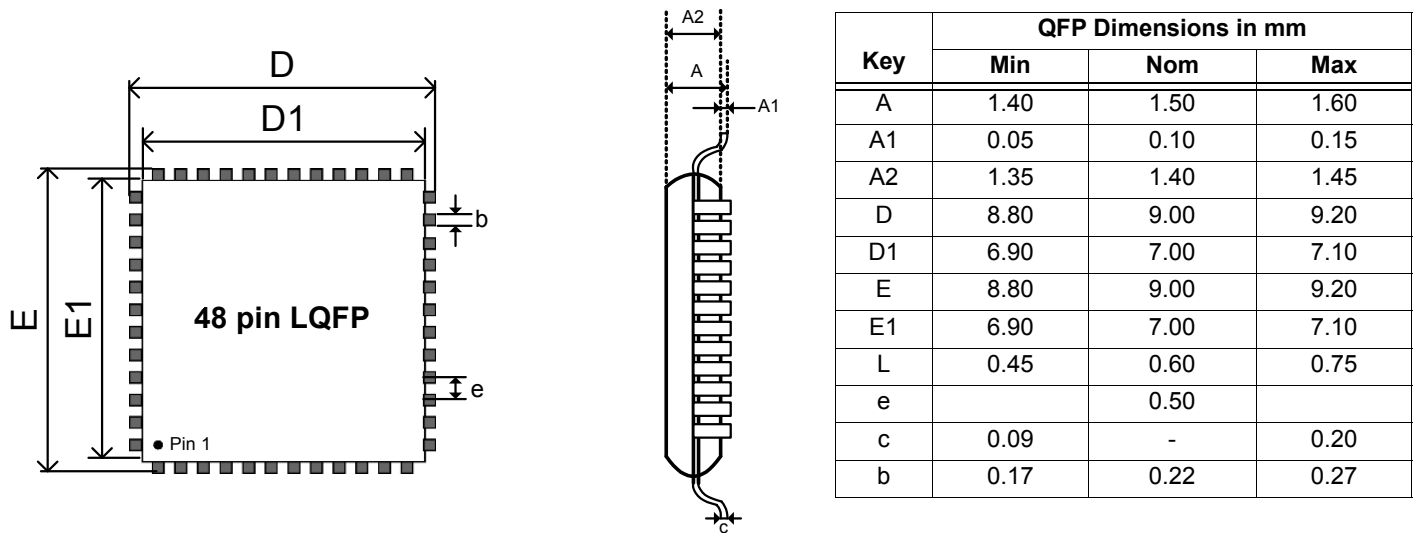

Figure 14. 48QFP Package Drawing

8.2. 40QFN Package

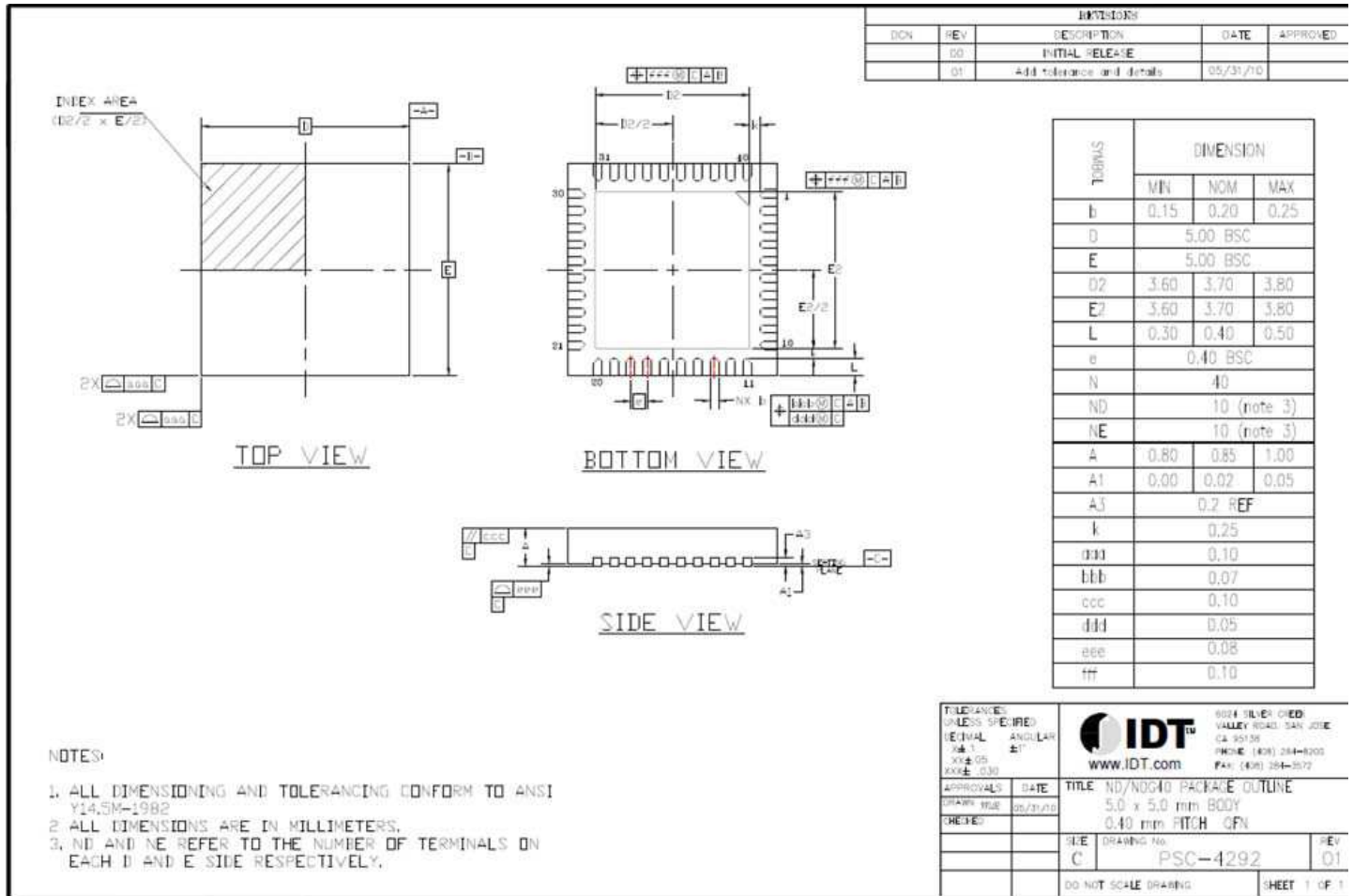

Figure 15. 40QFN Package Drawing

8.3. Standard Reflow Profile Data

Note: These devices can be hand soldered at 360 °C for 3 to 5 seconds.

FROM: IPC / JEDEC J-STD-020C "Moisture/Reflow Sensitivity Classification for Nonhermetic Solid State Surface Mount Devices" (www.jedec.org/download).

Profile Feature	Pb Free Assembly
Average Ramp-Up Rate ($T_{s_{max}} - T_p$)	3 °C / second max
Preheat: <ul style="list-style-type: none"> Temperature Min ($T_{s_{min}}$) Temperature Max ($T_{s_{max}}$) Time ($t_{s_{min}} - t_{s_{max}}$) 	150 °C 200 °C 60 - 180 seconds
Time maintained above: <ul style="list-style-type: none"> Temperature (T_L) Time (t_L) 	217 °C 60 - 150 seconds
Peak / Classification Temperature (T_p)	See "Package Classification Reflow Temperatures"

Table 25. Standard Reflow Profile

Profile Feature	Pb Free Assembly
Time within 5 °C of actual Peak Temperature (t_p)	20 - 40 seconds
Ramp-Down rate	6 °C / second max
Time 25 °C to Peak Temperature	8 minutes max

Note: All temperatures refer to topside of the package, measured on the package body surface.

Table 25. Standard Reflow Profile

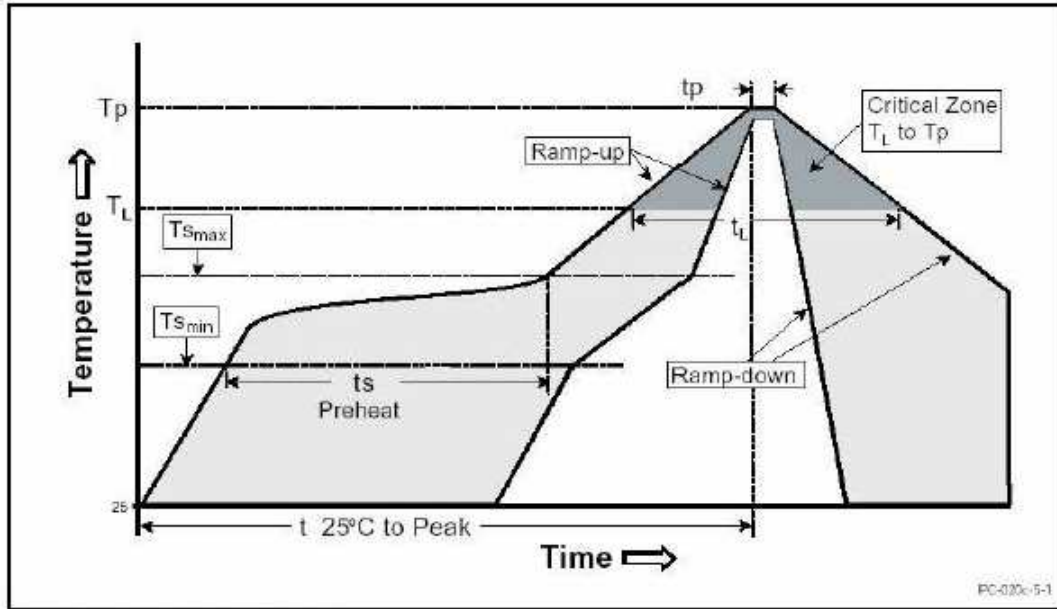

Figure 16. Solder Reflow Profile

8.4. Pb Free Process - Package Classification Reflow Temperatures

MSL	Reflow Temperature
3	260 °C

Table 26. Pb-Free Process Reflow

92HD73E

Ten Channel HD Audio Codec

9. DOCUMENT REVISION HISTORY

Revision	Date	Description of Change
0.5	April 25, 2007	Initial release
0.6	July 19, 2007	corrected type-os, replaced TBD in power consumption, updated widget and pinout description table and widget diagram, updated port configuration diagram
0.9	Oct 9, 2007	added detailed widget information, updated power consumption specification
0.91	Dec 14, 2007	updated Analog BC Peep description, updated the functional and widget diagrams for the new Analog PC Beep typology, added AnaBeep widget in AFG NID=-01h
1.0	March 19, 2008	removed preliminary, updated performance numbers
1.1	June 2011	Added 40QFN option. Added 48QFP Industrial temperature option. Removed all but 5V AVDD as an analog voltage option. Converted to newer datasheet template, updated software support section.
1.2	June 2011	Removed 40QFN device ID, all package options will have the same device ID.
1.3	August 2011	Updated 40QFN orderable part number and pinout.



6024 Silver Creek Valley Road
San Jose, California 95138

DISCLAIMER Integrated Device Technology, Inc. (IDT) and its subsidiaries reserve the right to modify the products and/or specifications described herein at any time and at IDT's sole discretion. All information in this document, including descriptions of product features and performance, is subject to change without notice. Performance specifications and the operating parameters of the described products are determined in the independent state and are not guaranteed to perform the same way when installed in customer products. The information contained herein is provided without representation or warranty of any kind, whether express or implied, including, but not limited to, the suitability of IDT's products for any particular purpose, an implied warranty of merchantability, or non-infringement of the intellectual property rights of others. This document is presented only as a guide and does not convey any license under intellectual property rights of IDT or any third parties.

IDT's products are not intended for use in life support systems or similar devices where the failure or malfunction of an IDT product can be reasonably expected to significantly affect the health or safety of users. Anyone using an IDT product in such a manner does so at their own risk, absent an express, written agreement by IDT.

Integrated Device Technology, IDT and the IDT logo are registered trademarks of IDT. Other trademarks and service marks used herein, including protected names, logos and designs, are the property of IDT or their respective third party owners.