



**21(+1) Channel
High-Density E1
Line Interface Unit
IDT82P2521**

**Version 1
December 7, 2005**

6024 Silver Creek Valley Road, San Jose, California 95138
Telephone: 1-800-345-7015 or 408-284-8200 • TWX: 910-338-2070 • FAX: 408-284-2775
Printed in U.S.A.
© 2005 Integrated Device Technology, Inc.

DISCLAIMER

Integrated Device Technology, Inc. reserves the right to make changes to its products or specifications at any time, without notice, in order to improve design or performance and to supply the best possible product. IDT does not assume any responsibility for use of any circuitry described other than the circuitry embodied in an IDT product. The Company makes no representations that circuitry described herein is free from patent infringement or other rights of third parties which may result from its use. No license is granted by implication or otherwise under any patent, patent rights or other rights, of Integrated Device Technology, Inc.

LIFE SUPPORT POLICY

Integrated Device Technology's products are not authorized for use as critical components in life support devices or systems unless a specific written agreement pertaining to such intended use is executed between the manufacturer and an officer of IDT.

1. Life support devices or systems are devices or systems which (a) are intended for surgical implant into the body or (b) support or sustain life and whose failure to perform, when properly used in accordance with instructions for use provided in the labeling, can be reasonably expected to result in a significant injury to the user.
 2. A critical component is any components of a life support device or system whose failure to perform can be reasonably expected to cause the failure of the life support device or system, or to affect its safety or effectiveness.
-



Table of Contents

TABLE OF CONTENTS	3
LIST OF TABLES	7
LIST OF FIGURES	8
FEATURES	10
APPLICATIONS.....	11
DESCRIPTION.....	11
BLOCK DIAGRAM	12
1 PIN ASSIGNMENT	13
2 PIN DESCRIPTION	18
3 FUNCTIONAL DESCRIPTION	29
3.1 RECEIVE PATH	29
3.1.1 Rx Termination	29
3.1.1.1 Receive Differential Mode	29
3.1.1.2 Receive Single Ended Mode	31
3.1.2 Equalizer	32
3.1.2.1 Line Monitor	32
3.1.2.2 Receive Sensitivity	32
3.1.3 Slicer	33
3.1.4 Rx Clock & Data Recovery	33
3.1.5 Decoder	33
3.1.6 Receive System Interface	33
3.1.7 Receiver Power Down	34
3.2 TRANSMIT PATH	34
3.2.1 Transmit System Interface	34
3.2.2 Tx Clock Recovery	35
3.2.3 Encoder	35
3.2.4 Waveform Shaper	35
3.2.4.1 Preset Waveform Template	35
3.2.4.2 User-Programmable Arbitrary Waveform	36
3.2.5 Line Driver	38
3.2.5.1 Transmit Over Current Protection	38
3.2.6 Tx Termination	38
3.2.6.1 Transmit Differential Mode	38
3.2.6.2 Transmit Single Ended Mode	39
3.2.7 Transmitter Power Down	40
3.2.8 Output High-Z on TTIP and TRING	40
3.3 JITTER ATTENUATOR (RJA & TJA)	41
3.4 DIAGNOSTIC FACILITIES	42

3.4.1	Bipolar Violation (BPV) / Code Violation (CV) Detection and BPV Insertion	42
3.4.1.1	Bipolar Violation (BPV) / Code Violation (CV) Detection	42
3.4.1.2	Bipolar Violation (BPV) Insertion	42
3.4.2	Excessive Zeroes (EXZ) Detection	42
3.4.3	Loss of Signal (LOS) Detection	43
3.4.3.1	Line LOS (LLOS)	43
3.4.3.2	System LOS (SLOS)	44
3.4.3.3	Transmit LOS (TLOS)	45
3.4.4	Alarm Indication Signal (AIS) Detection and Generation	46
3.4.4.1	Alarm Indication Signal (AIS) Detection	46
3.4.4.2	(Alarm Indication Signal) AIS Generation	46
3.4.5	PRBS, QRSS, ARB and IB Pattern Generation and Detection	47
3.4.5.1	Pattern Generation	47
3.4.5.2	Pattern Detection	48
3.4.6	Error Counter	49
3.4.6.1	Automatic Error Counter Updating	49
3.4.6.2	Manual Error Counter Updating	50
3.4.7	Receive /Transmit Multiplex Function (RMF / TMF) Indication	51
3.4.7.1	RMFn Indication	51
3.4.7.2	TMFn Indication	52
3.4.8	Loopback	53
3.4.8.1	Analog Loopback	53
3.4.8.2	Remote Loopback	54
3.4.8.3	Digital Loopback	55
3.4.8.4	Dual Loopback	56
3.4.9	Channel 0 Monitoring	58
3.4.9.1	G.772 Monitoring	58
3.4.9.2	Jitter Measurement (JM)	59
3.5	CLOCK INPUTS AND OUTPUTS	60
3.5.1	Free Running Clock Outputs on CLKE1	60
3.5.2	Clock Outputs on REFA/REFB	61
3.5.2.1	REFA/REFB in Clock Recovery Mode	61
3.5.2.2	Frequency Synthesizer for REFA Clock Output	61
3.5.2.3	Free Run Mode for REFA Clock Output	61
3.5.2.4	REFA/REFB Driven by External CLKA/CLKB Input	61
3.5.2.5	REFA and REFB in Loss of Signal (LOS) or Loss of Clock Condition	61
3.5.3	MCLK, Master Clock Input	65
3.5.4	XCLK, Internal Reference Clock Input	65
3.6	INTERRUPT SUMMARY	66
4	MISCELLANEOUS	68
4.1	RESET	68
4.1.1	Power-On Reset	69
4.1.2	Hardware Reset	69
4.1.3	Global Software Reset	69
4.1.4	Per-Channel Software Reset	69

4.2	MICROPROCESSOR INTERFACE	69
4.3	POWER UP	70
4.4	HITLESS PROTECTION SWITCHING (HPS) SUMMARY	70
5	PROGRAMMING INFORMATION	73
5.1	REGISTER MAP	73
5.1.1	Global Register	73
5.1.2	Per-Channel Register	74
5.2	REGISTER DESCRIPTION	77
5.2.1	Global Register	77
5.2.2	Per-Channel Register	85
6	JTAG	117
6.1	JTAG INSTRUCTION REGISTER (IR)	117
6.2	JTAG DATA REGISTER	117
6.2.1	Device Identification Register (IDR)	117
6.2.2	Bypass Register (BYP)	117
6.2.3	Boundary Scan Register (BSR)	117
6.3	TEST ACCESS PORT (TAP) CONTROLLER	117
7	THERMAL MANAGEMENT	119
7.1	JUNCTION TEMPERATURE	119
7.2	EXAMPLE OF JUNCTION TEMPERATURE CALCULATION	119
7.3	HEATSINK EVALUATION	119
8	PHYSICAL AND ELECTRICAL SPECIFICATIONS	120
8.1	ABSOLUTE MAXIMUM RATINGS	120
8.2	RECOMMENDED OPERATING CONDITIONS	121
8.3	DEVICE POWER CONSUMPTION AND DISSIPATION (TYPICAL) 1	122
8.4	DEVICE POWER CONSUMPTION AND DISSIPATION (MAXIMUM) 1	123
8.5	D.C. CHARACTERISTICS	124
8.6	E1 RECEIVER ELECTRICAL CHARACTERISTICS	125
8.7	E1 TRANSMITTER ELECTRICAL CHARACTERISTICS	126
8.8	TRANSMITTER AND RECEIVER TIMING CHARACTERISTICS	127
8.9	CLKE1 TIMING CHARACTERISTICS	129
8.10	JITTER ATTENUATION CHARACTERISTICS	129
8.11	MICROPROCESSOR INTERFACE TIMING	132
8.11.1	Serial Microprocessor Interface	132
8.11.2	Parallel Motorola Non-Multiplexed Microprocessor Interface	134
8.11.2.1	Read Cycle Specification	134
8.11.2.2	Write Cycle Specification	135
8.11.3	Parallel Intel Non-Multiplexed Microprocessor Interface	136
8.11.3.1	Read Cycle Specification	136
8.11.3.2	Write Cycle Specification	137
8.11.4	Parallel Motorola Multiplexed Microprocessor Interface	138
8.11.4.1	Read Cycle Specification	138
8.11.4.2	Write Cycle Specification	139

8.11.5 Parallel Intel Multiplexed Microprocessor Interface	140
8.11.5.1 Read Cycle Specification	140
8.11.5.2 Write Cycle Specification	141
8.12 JTAG TIMING CHARACTERISTICS	142
GLOSSARY	143
INDEX	145
ORDERING INFORMATION	147



List of Tables

Table-1	Impedance Matching Value in Receive Differential Mode	30
Table-2	Multiplex Pin Used in Receive System Interface	33
Table-3	Multiplex Pin Used in Transmit System Interface	35
Table-4	PULS[3:0] Setting	36
Table-5	Transmit Waveform Value for E1 75 ohm	37
Table-6	Transmit Waveform Value for E1 120 ohm	37
Table-7	Impedance Matching Value in Transmit Differential Mode	38
Table-8	EXZ Definition	42
Table-9	LLOS Criteria	43
Table-10	SLOS Criteria	44
Table-11	TLOS Detection Between Two Channels	45
Table-12	AIS Criteria	46
Table-13	RMFn Indication	51
Table-14	TMFn Indication	52
Table-15	Clock Output on CLKE1	60
Table-16	Interrupt Summary	66
Table-17	After Reset Effect Summary	68
Table-18	Microprocessor Interface	69



List of Figures

Figure-1	Functional Block Diagram	12
Figure-2	640-Pin TEPBGA (Top View) - Outline	13
Figure-3	640-Pin TEPBGA (Top View) - Top Left	14
Figure-4	640-Pin TEPBGA (Top View) - Top Right	15
Figure-5	640-Pin TEPBGA (Top View) - Bottom Left	16
Figure-6	640-Pin TEPBGA (Top View) - Bottom Right	17
Figure-7	Switch between Impedance Matching Modes	29
Figure-8	Receive Differential Line Interface with Twisted Pair Cable (with transformer)	30
Figure-9	Receive Differential Line Interface with Coaxial Cable (with transformer)	30
Figure-10	Receive Differential Line Interface with Twisted Pair Cable (transformer-less, non standard compliant)	30
Figure-11	Receive Single Ended Line Interface with Coaxial Cable (with transformer)	31
Figure-12	Receive Single Ended Line Interface with Coaxial Cable (transformer-less, non standard compliant)	31
Figure-13	Receive Path Monitoring	32
Figure-14	Transmit Path Monitoring	32
Figure-15	E1 Waveform Template	35
Figure-16	E1 Waveform Template Measurement Circuit	35
Figure-17	Transmit Differential Line Interface with Twisted Pair Cable (with Transformer)	39
Figure-18	Transmit Differential Line Interface with Coaxial Cable (with transformer)	39
Figure-19	Transmit Differential Line Interface with Twisted Pair Cable (transformer-less, non standard compliant)	39
Figure-20	Transmit Single Ended Line Interface with Coaxial Cable (with transformer)	39
Figure-21	Jitter Attenuator	41
Figure-22	LLOS Indication on Pins	43
Figure-23	TLOS Detection Between Two Channels	45
Figure-24	Pattern Generation (1)	47
Figure-25	Pattern Generation (2)	47
Figure-26	PRBS / ARB Detection	48
Figure-27	IB Detection	49
Figure-28	Automatic Error Counter Updating	50
Figure-29	Manual Error Counter Updating	50
Figure-30	Priority Of Diagnostic Facilities During Analog Loopback	53
Figure-31	Priority Of Diagnostic Facilities During Manual Remote Loopback	54
Figure-32	Priority Of Diagnostic Facilities During Digital Loopback	55
Figure-33	Priority Of Diagnostic Facilities During Manual Remote Loopback + Manual Digital Loopback	57
Figure-34	Priority Of Diagnostic Facilities During Manual Remote Loopback + Automatic Digital Loopback	57
Figure-35	G.772 Monitoring	58
Figure-36	Automatic JM Updating	59
Figure-37	Manual JM Updating	59
Figure-38	REFA Output Options in Normal Operation	62
Figure-39	REFB Output Options in Normal Operation	63
Figure-40	REFA Output in LLOS Condition (When RCLKn Is Selected)	63
Figure-41	REFA Output in No CLKA Condition (When CLKA Is Selected)	64
Figure-42	Interrupt Service Process	67
Figure-43	Reset	68
Figure-44	1+1 HPS Scheme, Differential Interface (Shared Common Transformer)	70
Figure-45	1:1 HPS Scheme, Differential Interface (Individual Transformer)	71
Figure-46	1+1 HPS Scheme, E1 75 ohm Single-Ended Interface (Shared Common Transformer)	72
Figure-47	JTAG Architecture	117
Figure-48	JTAG State Diagram	118

Figure-49 Transmit Clock Timing Diagram	128
Figure-50 Receive Clock Timing Diagram	128
Figure-51 CLKE1 Clock Timing Diagram	129
Figure-52 E1 Jitter Tolerance Performance	130
Figure-53 E1 Jitter Transfer Performance	131
Figure-54 Read Operation in Serial Microprocessor Interface	132
Figure-55 Write Operation in Serial Microprocessor Interface	132
Figure-56 Timing Diagram	133
Figure-57 Parallel Motorola Non-Multiplexed Microprocessor Interface Read Cycle	134
Figure-58 Parallel Motorola Non-Multiplexed Microprocessor Interface Write Cycle	135
Figure-59 Parallel Intel Non-Multiplexed Microprocessor Interface Read Cycle	136
Figure-60 Parallel Intel Non-Multiplexed Microprocessor Interface Write Cycle	137
Figure-61 Parallel Motorola Multiplexed Microprocessor Interface Read Cycle	138
Figure-62 Parallel Motorola Multiplexed Microprocessor Interface Write Cycle	139
Figure-63 Parallel Intel Multiplexed Microprocessor Interface Read Cycle	140
Figure-64 Parallel Intel Multiplexed Microprocessor Interface Write Cycle	141
Figure-65 JTAG Timing	142



21(+1) Channel High-Density E1 Line Interface Unit

IDT82P2521

FEATURES

- ◆ **Integrates 21+1 channels E1 short haul line interface units for 120 Ω E1 twisted pair cable and 75 Ω E1 coaxial cable applications**
- ◆ **Per-channel configurable Line Interface options**
 - Supports various line interface options
 - *Differential and Single Ended line interfaces*
 - *true Single Ended termination on primary and secondary side of transformer for E1 75 Ω coaxial cable applications*
 - *transformer-less for Differential interfaces*
 - Fully integrated and software selectable receive and transmit termination
 - *Option 1: Fully Internal Impedance Matching with integrated receive termination resistor*
 - *Option 2: Partially Internal Impedance Matching with common external resistor for improved device power dissipation*
 - *Option 3: External impedance Matching termination*
 - Supports global configuration and per-channel configuration to E1 mode
- ◆ **Per-channel programmable features**
 - Provides E1 short haul waveform templates and user-programmable arbitrary waveform templates
 - Provides two JAs (Jitter Attenuator) for each channel of receiver and transmitter
 - Supports AMI/HDB3 encoding and decoding
- ◆ **Per-channel System Interface options**
 - Supports Single Rail, Dual Rail with clock or without clock and sliced system interface
 - Integrated Clock Recovery for the transmit interface to recover transmit clock from system transmit data
- ◆ **Per-channel system and diagnostic functions**
 - Provides transmit driver over-current detection and protection with optional automatic high impedance of transmit interface
 - Detects and generates PRBS (Pseudo Random Bit Sequence), ARB (Arbitrary Pattern) and IB (Inband Loopback) in either receive or transmit direction
 - Provides defect and alarm detection in both receive and transmit directions.
 - *Defects include BPV (Bipolar Violation) /CV (Code Violation) and EXZ (Excessive Zeroes)*
 - *Alarms include LLOS (Line LOS), SLOS (System LOS), TLOS (Transmit LOS) and AIS (Alarm Indication Signal)*
 - Programmable LLOS detection /clear levels. Compliant with ITU and ANSI specifications
 - Various pattern, defect and alarm reporting options
 - *Serial hardware LLOS reporting (LLOS, LLOS0) for all 22 channels*
 - *Configurable per-channel hardware reporting with RMF/TMF (Receive /Transmit Multiplex Function)*
 - *Register access to individual registers or 16-bit error counters*
- Supports Analog Loopback, Digital Loopback and Remote Loopback
- Supports T1.102 line monitor
- ◆ **Channel 0 monitoring options**
 - Channel 0 can be configured as monitoring channel or regular channel to increase capacity
 - Supports all internal G.772 Monitoring for Non-Intrusive Monitoring of any of the 21 channels of receiver or transmitter
 - Jitter Measurement per ITU O.171
- ◆ **Hitless Protection Switching (HPS) without external Relays**
 - Supports 1+1 and 1:1 hitless protection switching
 - Asynchronous hardware control (OE, RIM) for fast global high impedance of receiver and transmitter (hot switching between working and backup board)
 - High impedance transmitter and receiver while powered down
 - Per-channel register control for high impedance, independent for receiver and transmitter
- ◆ **Clock Inputs and Outputs**
 - Flexible master clock ($N \times 2.048$ MHz) ($1 \leq N \leq 8$, N is an integer number)
 - Two selectable reference clock outputs
 - *from the recovered clock of any of the 22 channels*
 - *from external clock input*
 - *from device master clock*
 - Integrated clock synthesizer can multiply or divide the reference clock to a wide range of frequencies: 8 KHz, 64 KHz, 2.048 MHz, 4.096 MHz, 8.192 MHz, 19.44 MHz and 32.768 MHz
 - Cascading is provided to select a single reference clock from multiple devices without the need for any external logic
- ◆ **Microprocessor Interface**
 - Supports Serial microprocessor interface and Parallel Intel / Motorola Non-Multiplexed /Multiplexed microprocessor interface
- ◆ **Other Key Features**
 - IEEE1149.1 JTAG boundary scan
 - Two general purpose I/O pins
 - 3.3 V I/O with 5 V tolerant inputs
 - 3.3 V and 1.8 V power supply
 - Package: 640-pin TEPBGA (31 mm X 31 mm)
- ◆ **Applicable Standards**
 - AT&T Pub 62411 Accunet T1.5 Service
 - ANSI T1.102 and T1.403
 - Bellcore TR-TSY-000009, GR-253-CORE and GR-499-CORE
 - ETSI CTR12/13
 - ETS 300166 and ETS 300 233
 - G.703, G.735, G.736, G.742, G.772, G.775, G.783 and G.823
 - O.161
 - ITU I.431 and ITU O.171

APPLICATIONS

- ◆ SDH/SONET multiplexers
- ◆ Central office or PBX (Private Branch Exchange)
- ◆ Digital access cross connects
- ◆ Remote wireless modules
- ◆ Microwave transmission systems

DESCRIPTION

The IDT82P2521 is a 21+1 channels high-density E1 short haul Line Interface Unit. Each channel of the IDT82P2521 can be independently configured. The configuration is performed through a Serial or Parallel Intel/Motorola Non-Multiplexed /Multiplexed microprocessor interface.

In the receive path, through a Single Ended or Differential line interface, the received signal is processed by an adaptive Equalizer and then sent to a Slicer. Clock and data are recovered from the digital pulses output from the Slicer. After passing through an enabled or disabled Receive Jitter Attenuator, the recovered data is decoded using AMI/HDB3 line code rule in Single Rail NRZ Format mode and output to the system, or output to the system without decoding in Dual Rail NRZ Format mode and Dual Rail RZ Format mode.

In the transmit path, the data to be transmitted is input on TDn in Single Rail NRZ Format mode or TDPn/TDNn in Dual Rail NRZ Format mode and Dual Rail RZ Format mode, and is sampled by a transmit reference clock. The clock can be supplied externally from TCLKn or recovered from the input transmit data by an internal Clock Recovery. A selectable JA in Tx path is used to de-jitter gapped clocks. To meet E1 waveform standards, two E1 templates, as well as an arbitrary waveform generator are provided. The data through the Waveform Shaper, the Line Driver and the Tx Transmitter is output on TTIPn and TRINGn.

Alarms (including LOS, AIS) and defects (including BPV, EXZ) are detected in both receive line side and transmit system side. AIS alarm, PRBS, ARB and IB patterns can be generated /detected in receive / transmit direction for testing purpose. Analog Loopback, Digital Loopback and Remote Loopback are all integrated for diagnostics.

Channel 0 is a special channel. Besides normal operation as the other 21 channels, channel 0 also supports G.772 Monitoring and Jitter Measurement per ITU O.171.

A line monitor function per T1.102 is available to provide a Non-Intrusive Monitoring of channels of other devices.

JTAG per IEEE 1149.1 is also supported by the IDT82P2521.

BLOCK DIAGRAM

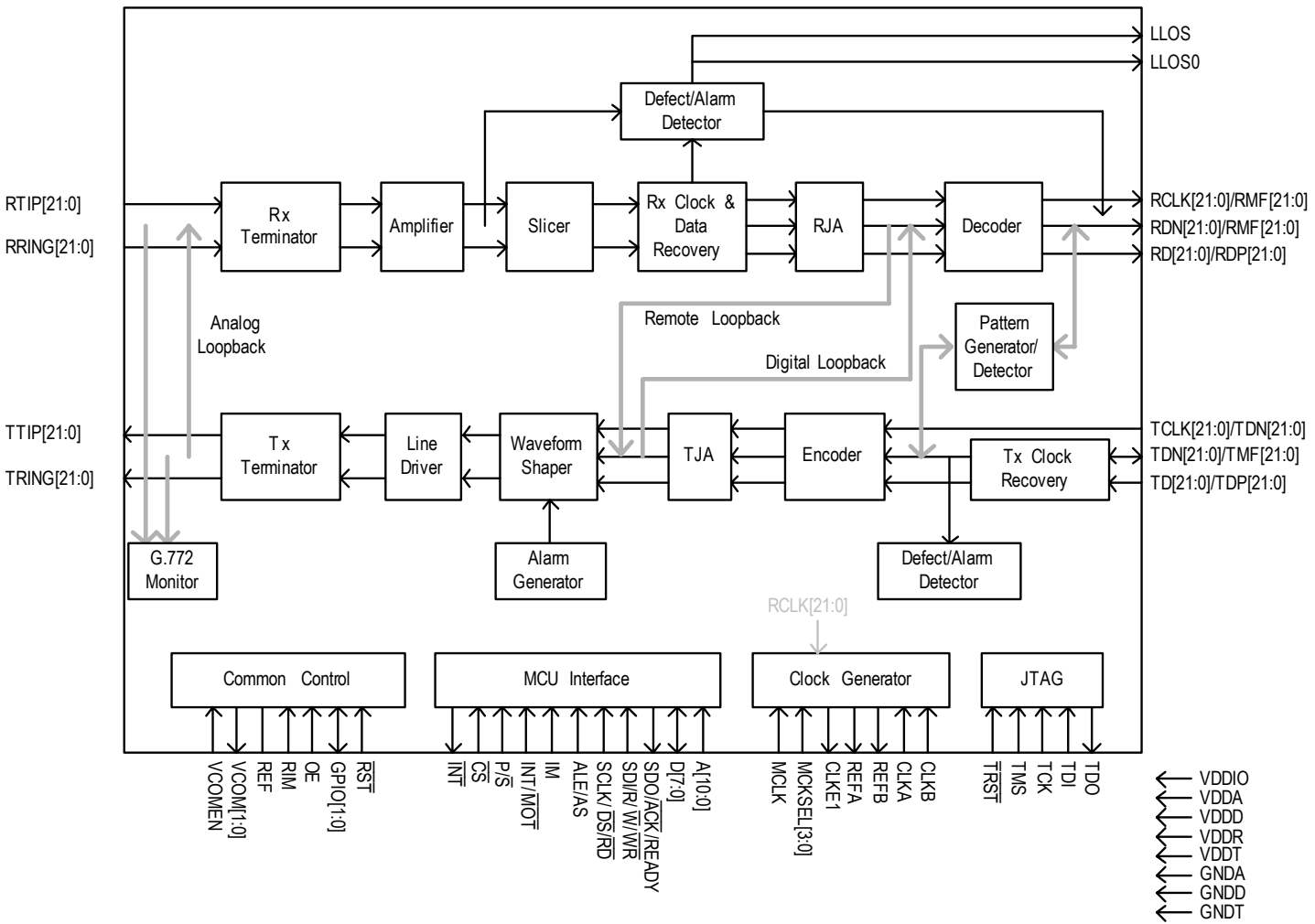

Figure-1 Functional Block Diagram

1 PIN ASSIGNMENT

Figure-2 shows the outline of the pin assignment. For a clearer description, four segments are divided in this figure and the details of each are shown from Figure-3 to Figure-6.

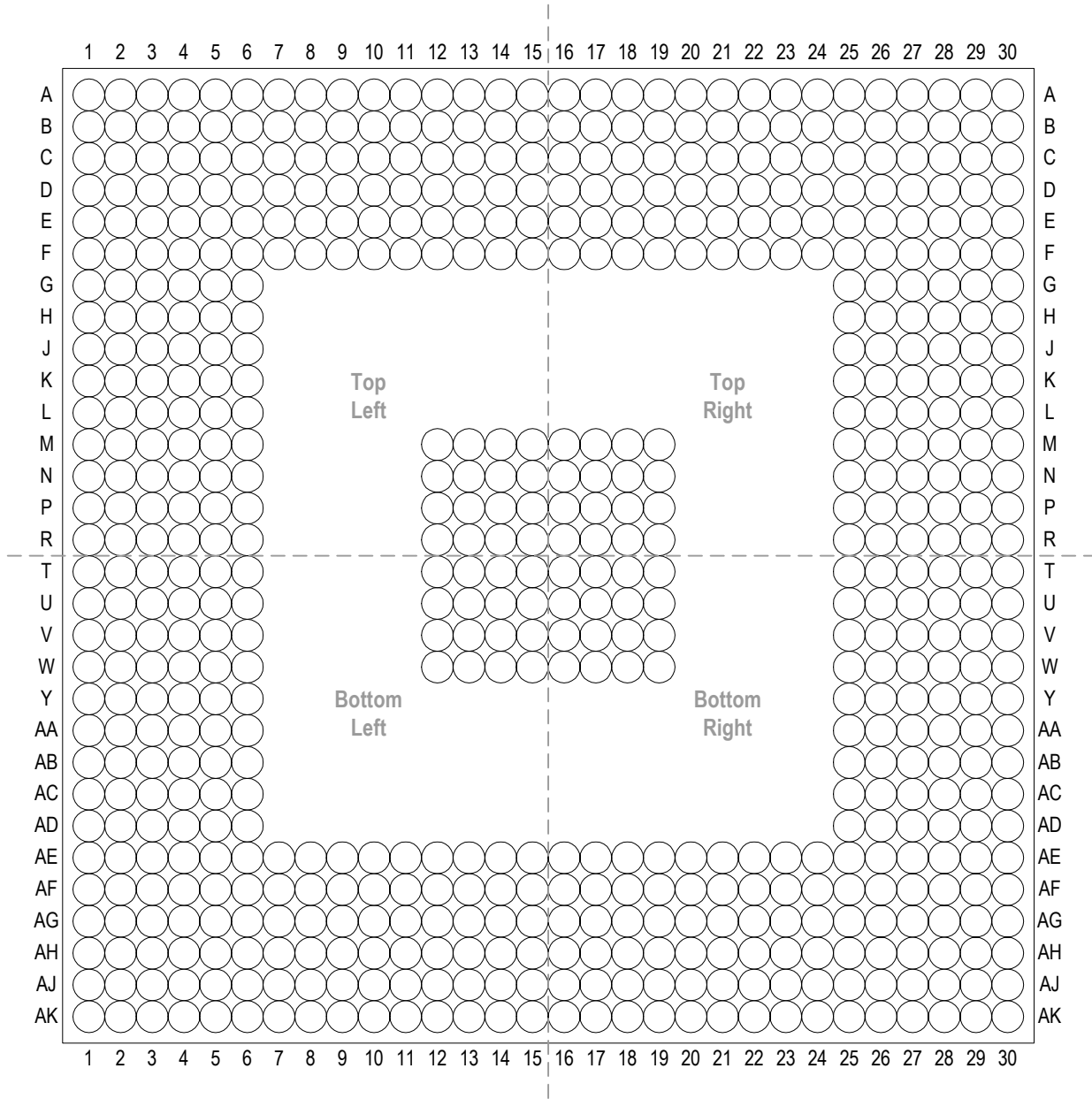

Figure-2 640-Pin TEPBGA (Top View) - Outline

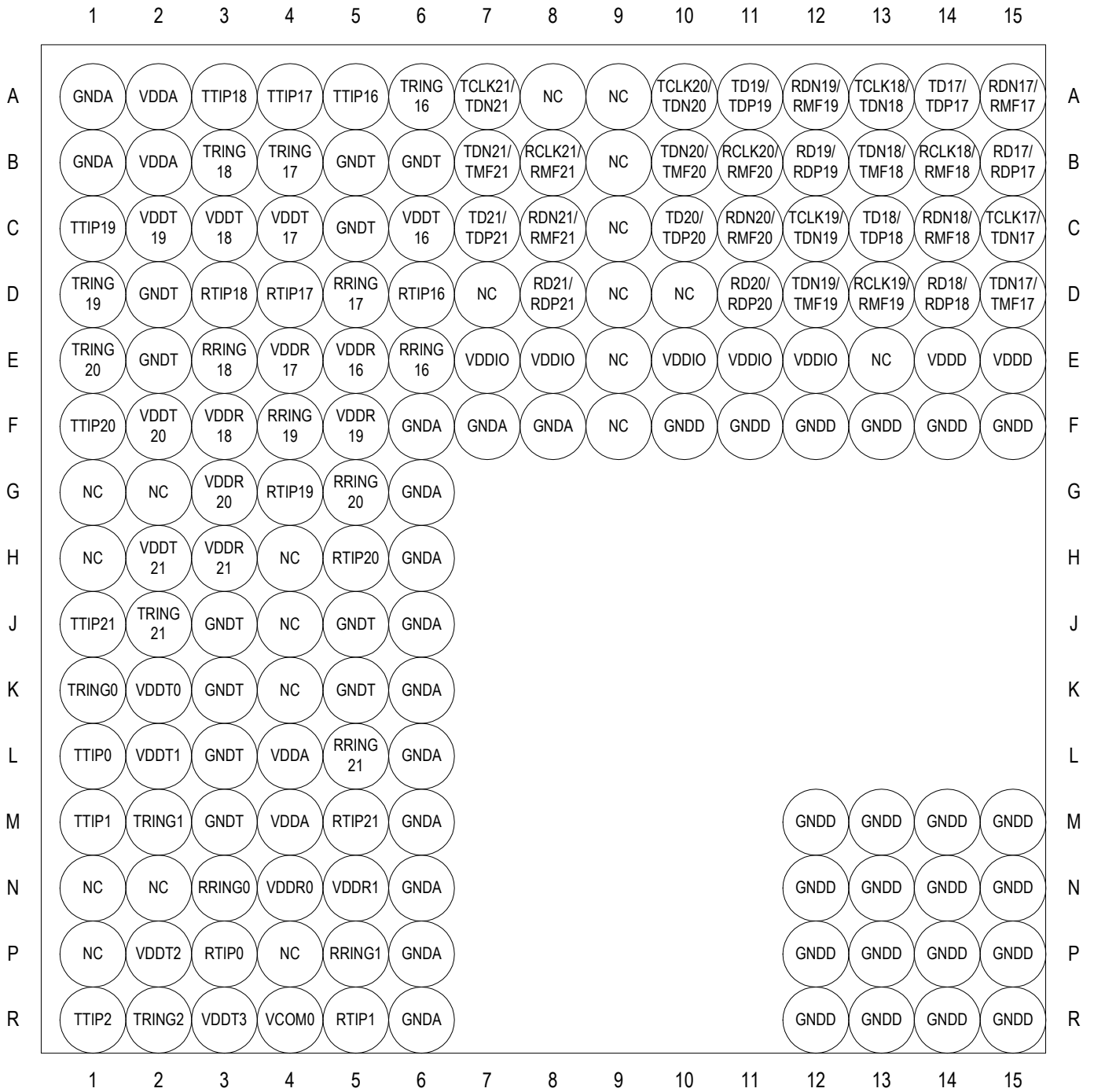

Figure-3 640-Pin TEPBGA (Top View) - Top Left

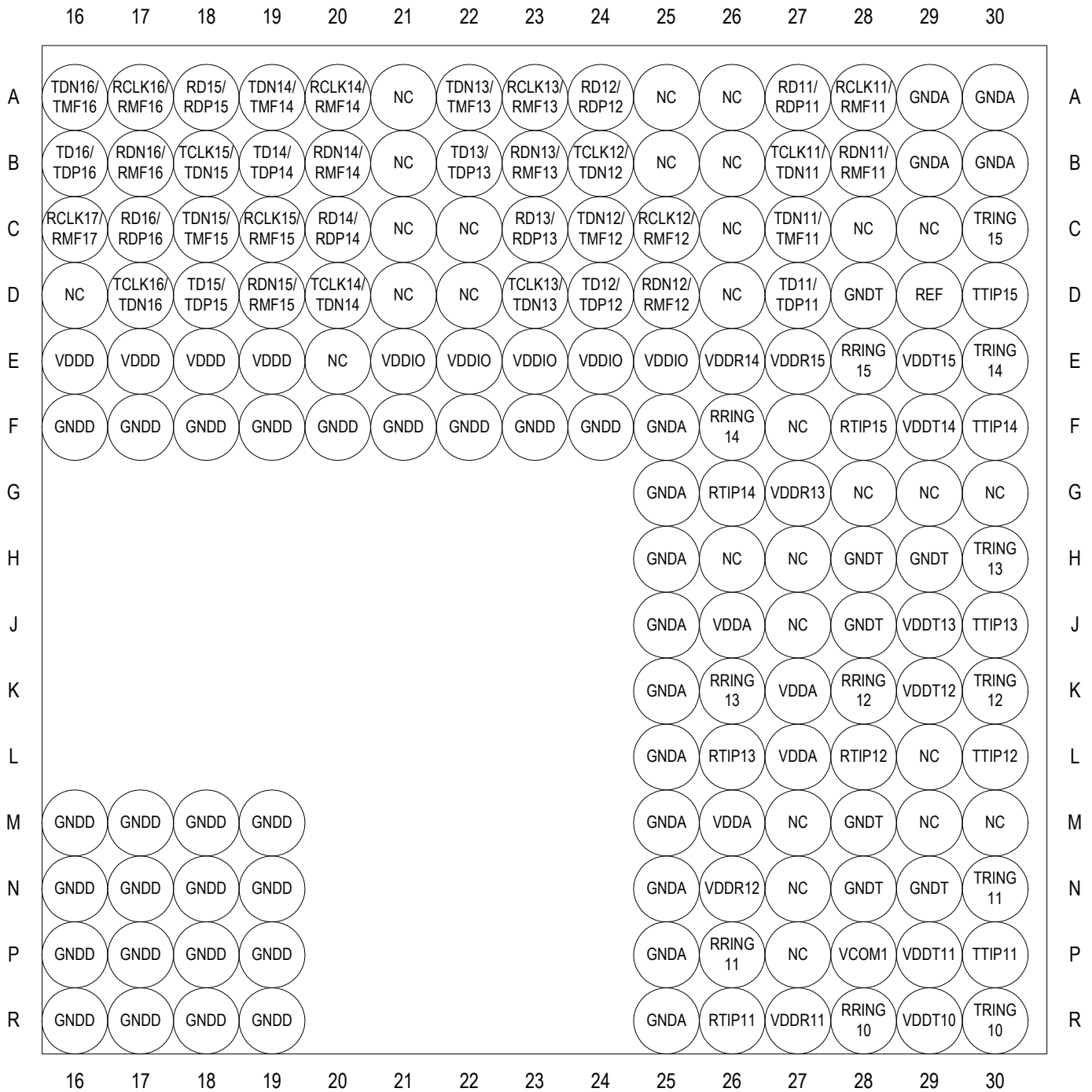

Figure-4 640-Pin TEPBGA (Top View) - Top Right

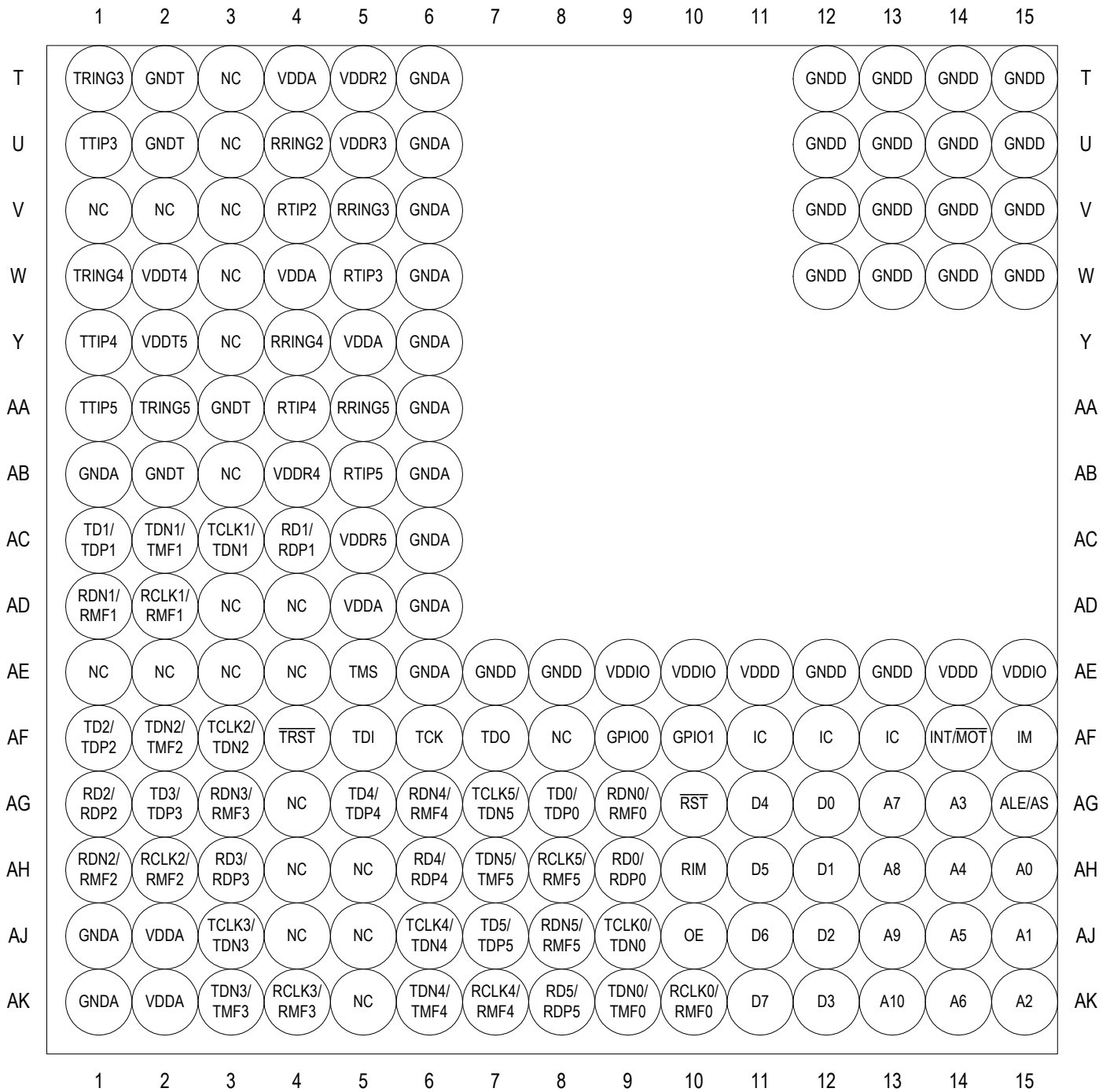

Figure-5 640-Pin TEPBGA (Top View) - Bottom Left

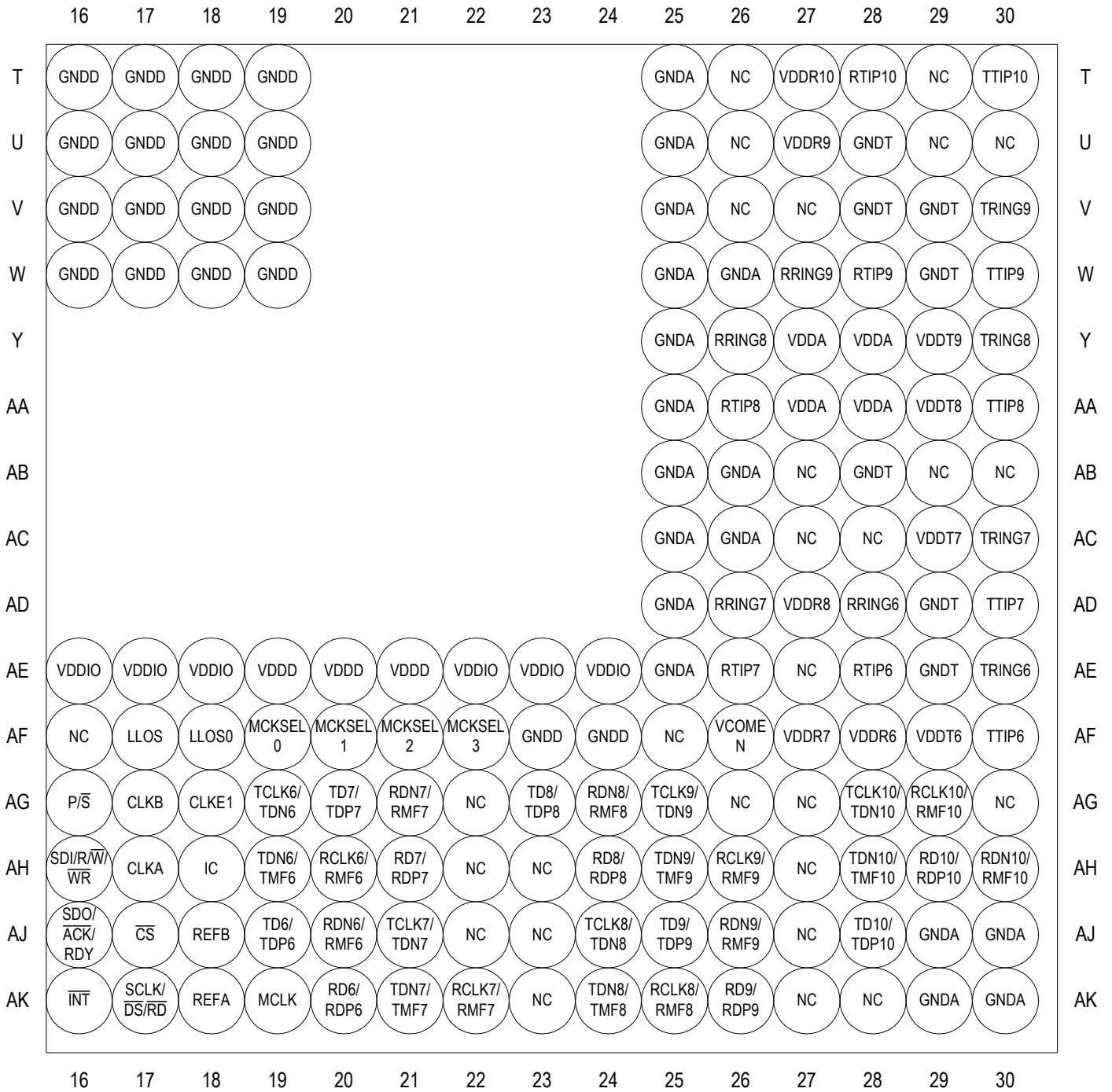

Figure-6 640-Pin TEPBGA (Top View) - Bottom Right

2 PIN DESCRIPTION

Name	I/O	Pin No. ¹	Description
Line Interface			
RTIPn RRINGn (n=0~21)	Input	P3, R5, V4, W5, AA4, AB5, AE28, AE26, AA26, W28, T28, R26, L28, L26, G26, F28, D6, D4, D3, G4, H5, M5 N3, P5, U4, V5, Y4, AA5, AD28, AD26, Y26, W27, R28, P26, K28, K26, F26, E28, E6, D5, E3, F4, G5, L5	<p>RTIPn / RRINGn: Receive Bipolar Tip/Ring for Channel 0 ~ 21</p> <p>The receive line interface supports both Receive Differential mode and Receive Single Ended mode.</p> <p>In Receive Differential mode, the received signal is coupled into RTIPn and RRINGn via a 1:1 transformer or without a transformer (transformer-less).</p> <p>In Receive Single Ended mode, RRINGn should be left open. The received signal is input on RTIPn via a 2:1 (step down) transformer or without a transformer (transformer-less).</p> <p>These pins will become High-Z globally or channel specific in the following conditions:</p> <ul style="list-style-type: none"> • Global High-Z: <ul style="list-style-type: none"> - Connecting the RIM pin to low; - Loss of MCLK - During and after power-on reset, hardware reset or global software reset; • Per-channel High-Z <ul style="list-style-type: none"> - Receiver power down by writing '1' to the R_OFF bit (b5, RCF0,...)
TTIPn TRINGn (n=0~21)	Output	L1, M1, R1, U1, Y1, AA1, AF30, AD30, AA30, W30, T30, P30, L30, J30, F30, D30, A5, A4, A3, C1, F1, J1 K1, M2, R2, T1, W1, AA2, AE30, AC30, Y30, V30, R30, N30, K30, H30, E30, C30, A6, B4, B3, D1, E1, J2	<p>TTIPn / TRINGn: Transmit Bipolar Tip /Ring for Channel 0 ~ 21</p> <p>The transmit line interface supports both Transmit Differential mode and Transmit Single Ended mode.</p> <p>In Transmit Differential mode, TTIPn outputs a positive differential pulse while TRINGn outputs a negative differential pulse. The pulses are coupled to the line side via a 1:2 (step up) transformer or without a transformer (transformer-less).</p> <p>In Transmit Single Ended mode, TRINGn should be left open (it is shorted to ground internally). The signal presented at TTIPn is output to the line side via a 1:2 (step up) transformer.</p> <p>These pins will become High-Z globally or channel specific in the following conditions:</p> <ul style="list-style-type: none"> • Global High-Z: <ul style="list-style-type: none"> - Connecting the OE pin to low; - Loss of MCLK; - During and after power-on reset, hardware reset or global software reset; • Per-channel High-Z <ul style="list-style-type: none"> - Writing '0' to the OE bit (b6, TCF0,...) ²; - Loss of TCLKn in Transmit Single Rail NRZ Format mode or Transmit Dual Rail NRZ Format mode, except that the channel is in Remote Loopback or transmit internal pattern with XCLK ³; - Transmitter power down by writing '1' to the T_OFF bit (b5, TCF0,...); - Per-channel software reset; - The THZ_OC bit (b4, TCF0,...) is set to '1' and the transmit driver over-current is detected. <p>Refer to Section 3.2.8 Output High-Z on TTIP and TRING for details.</p>

Note:

1. The pin number of the pins with the footnote 'n' is listed in order of channel (CH0 ~ CH21).
2. The content in the brackets indicates the position and the register name of the preceding bit. After the register name, if the punctuation '...' is followed, this bit is in a per-channel register. If there is no punctuation following the address, this bit is in a global register or in a channel 0 only register. The addresses and details are included in Chapter 5 Programming Information.
3. XCLK is derived from MCLK. It is 2.048 MHz.

Name	I / O	Pin No.	Description
System Interface			
RDn / RDPn (n=0~21)	Output	AH9, AC4, AG1, AH3, AH6, AK8, AK20, AH21, AH24, AK26, AH29, A27, A24, C23, C20, A18, C17, B15, D14, B12, D11, D8	<p>RDn: Receive Data for Channel 0 ~ 21 When the receive system interface is configured to Single Rail NRZ Format mode, this multiplex pin is used as RDn. The decoded NRZ data is updated on the active edge of RCLKn. The active level on RDn is selected by the RD_INV bit (b3, RCF1,...). When the receiver is powered down, RDn will be in High-Z state or low, as selected by the RHZ bit (b6, RCF0,...).</p> <p>RDPn: Positive Receive Data for Channel 0 ~ 21 When the receive system interface is configured to Dual Rail NRZ Format mode, Dual Rail RZ Format mode or Dual Rail Sliced mode, this multiplex pin is used as RDPn. In Receive Dual Rail NRZ Format mode, the un-decoded NRZ data is output on RDPn and RDNn and updated on the active edge of RCLKn. In Receive Dual Rail RZ Format mode, the un-decoded RZ data is output on RDPn and RDNn and updated on the active edge of RCLKn. In Receive Dual Rail Sliced mode, the raw RZ sliced data is output on RDPn and RDNn. For Receive Differential line interface, an active level on RDPn indicates the receipt of a positive pulse on RTIPn and a negative pulse on RRINGn; while an active level on RDNn indicates the receipt of a negative pulse on RTIPn and a positive pulse on RRINGn. For Receive Single Ended line interface, an active level on RDPn indicates the receipt of a positive pulse on RTIPn; while an active level on RDNn indicates the receipt of a negative pulse on RTIPn. The active level on RDPn and RDNn is selected by the RD_INV bit (b3, RCF1,...). When the receiver is powered down, RDPn and RDNn will be in High-Z state or low, as selected by the RHZ bit (b6, RCF0,...).</p>
RDNn / RMFn (n=0~21)	Output	AG9, AD1, AH1, AG3, AG6, AJ8, AJ20, AG21, AG24, AJ26, AH30, B28, D25, B23, B20, D19, B17, A15, C14, A12, C11, C8	<p>RDNn: Negative Receive Data for Channel 0 ~ 21 When the receive system interface is configured to Dual Rail NRZ Format mode, Dual Rail RZ Format mode or Dual Rail Sliced mode, this multiplex pin is used as RDNn. (Refer to the description of RDPn for details).</p> <p>RMFn: Receive Multiplex Function for Channel 0 ~ 21 When the receive system interface is configured to Single Rail NRZ Format mode, this multiplex pin is used as RMFn. RMFn is configured by the RMF_DEF[2:0] bits (b7~5, RCF1,...) and can indicate PRBS/ARB, LAIS, LEXZ, LBPV, LEXZ+LBPV, LLOS, output recovered clock (RCLK) or XOR output of positive and negative sliced data. Refer to Section 3.4.7.1 RMFn Indication for details. The output on RMFn is updated on the active edge of RCLKn. The active level of RMFn is always high. When the receiver is powered down, RMFn will be in High-Z state or low, as selected by the RHZ bit (b6, RCF0,...).</p>

Name	I / O	Pin No.	Description
RCLKn / RMFn (n=0~21)	Output	AK10, AD2, AH2, AK4, AK7, AH8, AH20, AK22, AK25, AH26, AG29, A28, C25, A23, A20, C19, A17, C16, B14, D13, B11, B8	<p>RCLKn: Receive Clock for Channel 0 ~ 21 When the receive system interface is configured to Single Rail NRZ Format mode, Dual Rail NRZ Format mode or Dual Rail RZ Format mode, this multiplex pin is used as RCLKn. RCLKn outputs a 2.048 MHz clock which is recovered from the received signal. The data output on RDn and RMFn (in Receive Single Rail NRZ Format mode) or RDPn/RDNn (in Receive Dual Rail NRZ Format mode, Receive Dual Rail RZ Format mode and Receive Dual Rail Sliced) is updated on the active edge of RCLKn. The active edge is selected by the RCK_ES bit (b4, RCF1,...). In LLOS condition, RCLKn output high or XCLK, as selected by the RCKH bit (b7, RCF0,...) (refer to Section 3.4.3.1 Line LOS (LLOS) for details). When the receiver is powered down, RCLKn will be in High-Z state or low, as selected by the RHZ bit (b6, RCF0,...).</p> <p>RMFn: Receive Multiplex Function for Channel 0 ~ 21 When the receive system interface is configured to Dual Rail Sliced mode, this multiplex pin is used as RMFn. (Refer to the description of RMFn of the RDNn/RMFn multiplex pin for details).</p>
LLOS	Output	AF17	<p>LLOS: Receive Line Loss Of Signal LLOS synchronizes with the output of CLKE1 and can indicate the LLOS (Line LOS) status of all 22 channels in a serial format. When the clock output on CLKE1 is enabled, LLOS indicates the LLOS status of the 22 channels in a serial format and repeats every twenty-two cycles. Channel 0 is positioned by LLOS0. Refer to the description of LLOS0 below for details. The last 7 redundant clock cycles are low and should be ignored. LLOS is updated on the rising edge of CLKE1 and is always active high. When the clock output of CLKE1 is disabled, LLOS will be held in High-Z state. (Refer to Section 3.4.3.1 Line LOS (LLOS) for details.)</p>
LLOS0	Output	AF18	<p>LLOS0: Receive Line Loss Of Signal for Channel 0 LLOS0 can indicate the position of channel 0 on the LLOS pin. When the clock output on CLKE1 is enabled, LLOS0 pulses high for one CLKE1 clock cycle to indicate the position of channel 0 on the LLOS pin. When CLKE1 outputs 8 KHz clock, LLOS0 pulses high for one 8 KHz clock cycle (125 μs) every twenty-nine 8 KHz clock cycles; when CLKE1 outputs 2.048 MHz clock, LLOS0 pulses high for one 2.048 MHz clock cycle (488 ns) every twenty-nine 2.048 MHz clock cycles. LLOS0 is updated on the rising edge of CLKE1. When the clock output on CLKE1 is disabled, LLOS0 will be held in High-Z state. (Refer to Section 3.4.3.1 Line LOS (LLOS) for details.)</p>

Name	I / O	Pin No.	Description																				
TDn / TDPn (n=0~21)	Input	AG8, AC1, AF1, AG2, AG5, AJ7, AJ19, AG20, AG23, AJ25, AJ28, D27, D24, B22, B19, D18, B16, A14, C13, A11, C10, C7	<p>TDn: Transmit Data for Channel 0 ~ 21 When the transmit system interface is configured to Single Rail NRZ Format mode, this multiplex pin is used as TDn. TDn accepts Single Rail NRZ data. The data is sampled into the device on the active edge of TCLKn. The active level on TDn is selected by the TD_INV bit (b3, TCF1,...).</p> <p>TDPn: Positive Transmit Data for Channel 0 ~ 21 When the transmit system interface is configured to Dual Rail NRZ Format mode or Dual Rail RZ Format mode, this multiplex pin is used as TDPn. In Transmit Dual Rail NRZ Format mode, the pre-encoded NRZ data is input on TDPn and TDNn and sampled on the active edge of TCLKn. In Transmit Dual Rail RZ Format mode, the pre-encoded RZ data is input on TDPn and TDNn. The line code is as follows (when the TD_INV bit (b3, TCF1,...) is '0'):</p> <table border="1"> <thead> <tr> <th>TDPn</th> <th>TDNn</th> <th>Output Pulse on TTIPn</th> <th>Output Pulse on TRINGn *</th> </tr> </thead> <tbody> <tr> <td>0</td> <td>0</td> <td>Space</td> <td>Space</td> </tr> <tr> <td>0</td> <td>1</td> <td>Negative Pulse</td> <td>Positive Pulse</td> </tr> <tr> <td>1</td> <td>0</td> <td>Positive Pulse</td> <td>Negative Pulse</td> </tr> <tr> <td>1</td> <td>1</td> <td>Space</td> <td>Space</td> </tr> </tbody> </table> <p>Note: * For Transmit Single Ended line interface, TRINGn should be open.</p> <p>The active level on TDPn and TDNn is selected by the TD_INV bit (b3, TCF1,...).</p>	TDPn	TDNn	Output Pulse on TTIPn	Output Pulse on TRINGn *	0	0	Space	Space	0	1	Negative Pulse	Positive Pulse	1	0	Positive Pulse	Negative Pulse	1	1	Space	Space
TDPn	TDNn	Output Pulse on TTIPn	Output Pulse on TRINGn *																				
0	0	Space	Space																				
0	1	Negative Pulse	Positive Pulse																				
1	0	Positive Pulse	Negative Pulse																				
1	1	Space	Space																				
TDNn / TMFn (n=0~21)	Input / Output	AK9, AC2, AF2, AK3, AK6, AH7, AH19, AK21, AK24, AH25, AH28, C27, C24, A22, A19, C18, A16, D15, B13, D12, B10, B7	<p>TDNn: Negative Transmit Data for Channel 0 ~ 21 When the transmit system interface is configured to Dual Rail NRZ Format mode, this multiplex pin is used as TDNn. (Refer to the description of TDPn for details).</p> <p>TMFn: Transmit Multiplex Function for Channel 0 ~ 21 When the transmit system interface is configured to Single Rail NRZ Format mode or Dual Rail RZ Format mode, this multiplex pin is used as TMFn. TMFn is configured by the TMF_DEF[2:0] bits (b7~5, TCF1,...) and can indicate PRBS/ARB, SAIS, TOC, TLOS, SEXZ, SBPV, SEXZ+SBPV, SLOS. Refer to Section 3.4.7.2 TMFn Indication for details. The output on TMFn is updated on the active edge of TCLKn (if available). The active level of TMFn is always high.</p>																				
TCLKn / TDNn (n=0~21)	Input	AJ9, AC3, AF3, AJ3, AJ6, AG7, AG19, AJ21, AJ24, AG25, AG28, B27, B24, D23, D20, B18, D17, C15, A13, C12, A10, A7	<p>TCLKn: Transmit Clock for Channel 0 ~ 21 When the transmit system interface is configured to Single Rail NRZ Format mode or Dual Rail NRZ Format mode, this multiplex pin is used as TCLKn. TCLKn inputs a 2.048 MHz clock. The data input on TDn (in Transmit Single Rail NRZ Format mode) or TDPn/TDNn (in Transmit Dual Rail NRZ Format mode) is sampled on the active edge of TCLKn. The data output on TMFn (in Transmit Single Rail NRZ Format mode) is updated on the active edge of TCLKn. The active edge is selected by the TCK_ES bit (b4, TCF1,...).</p> <p>TDNn: Negative Transmit Data for Channel 0 ~ 21 When the transmit system interface is configured to Dual Rail RZ Format mode, this multiplex pin is used as TDNn. (Refer to the description of TDPn for details).</p>																				

Name	I/O	Pin No.	Description																				
Clock																							
MCLK	Input	AK19	<p>MCLK: Master Clock Input</p> <p>MCLK provides a stable reference timing for the IDT82P2521. MCLK should be a jitter-free ¹ clock with ± 50 ppm accuracy. The clock frequency of MCLK is informed to the device by MCKSEL[3:0].</p> <p>If MCLK misses (duty cycle is less than 30% for 10 μs) and then recovers, the device will be reset automatically.</p>																				
MCKSEL[0] MCKSEL[1] MCKSEL[2] MCKSEL[3]	Input	AF19 AF20 AF21 AF22	<p>MCKSEL[3:0]: Master Clock Selection</p> <p>These four pins inform the device of the clock frequency input on MCLK:</p> <table border="1"> <thead> <tr> <th>MCKSEL[3:0]*</th> <th>Frequency (MHz)</th> </tr> </thead> <tbody> <tr> <td>1000</td> <td>2.048</td> </tr> <tr> <td>1001</td> <td>2.048 X 2</td> </tr> <tr> <td>1010</td> <td>2.048 X 3</td> </tr> <tr> <td>1011</td> <td>2.048 X 4</td> </tr> <tr> <td>1100</td> <td>2.048 X 5</td> </tr> <tr> <td>1101</td> <td>2.048 X 6</td> </tr> <tr> <td>1110</td> <td>2.048 X 7</td> </tr> <tr> <td>1111</td> <td>2.048 X 8</td> </tr> <tr> <td>others</td> <td>don't care</td> </tr> </tbody> </table> <p>Note: 0: GNDD 1: VDDIO</p>	MCKSEL[3:0]*	Frequency (MHz)	1000	2.048	1001	2.048 X 2	1010	2.048 X 3	1011	2.048 X 4	1100	2.048 X 5	1101	2.048 X 6	1110	2.048 X 7	1111	2.048 X 8	others	don't care
MCKSEL[3:0]*	Frequency (MHz)																						
1000	2.048																						
1001	2.048 X 2																						
1010	2.048 X 3																						
1011	2.048 X 4																						
1100	2.048 X 5																						
1101	2.048 X 6																						
1110	2.048 X 7																						
1111	2.048 X 8																						
others	don't care																						
CLKE1	Output	AG18	<p>CLKE1: 8 KHz / E1 Clock Output</p> <p>The output on CLKE1 can be enabled or disabled, as determined by the CLKE1_EN bit (b3, CLKG).</p> <p>When the output is enabled, CLKE1 outputs an 8 KHz or 2.048 MHz clock, as selected by the CLKE1 bit (b2, CLKG). The output is locked to MCLK.</p> <p>When the output is disabled, CLKE1 is in High-Z state.</p>																				
REFA	Output	AK18	<p>REFA: Reference Clock Output A</p> <p>REFA can output three kinds of clocks: a recovered clock of one of the 22 channels, an external clock input on CLKA or a free running clock. The clock frequency is programmable. Refer to Section 3.5.2 Clock Outputs on REFA/REFB for details.</p> <p>The output on REFA can also be disabled, as determined by the REFA_EN bit (b6, REFA).</p> <p>When the output is disabled, REFA is in High-Z state.</p>																				

Note:

1. jitter is no more than 0.001 UI.

Name	I / O	Pin No.	Description
REFB	Output	AJ18	REFB: Reference Clock Output B REFB can output a recovered clock of one of the 22 channels, an external clock input on CLKB or a free running clock. Refer to Section 3.5.2 Clock Outputs on REFA/REFB for details. The output on REFB can also be disabled, as determined by the REFB_EN bit (b6, REFB). When the output is disabled, REFB is in High-Z state.
CLKA	Input	AH17	CLKA: External E1 Clock Input A External E1 clock is input on this pin. The CKA_E1 bit (b5, REFA) should be set to match the clock frequency. When not used, this pin should be connected to GNDD.
CLKB	Input	AG17	CLKB: External E1 Clock Input B External E1 clock is input on this pin. The CKB_E1 bit (b5, REFB) should be set to match the clock frequency. When not used, this pin should be connected to GNDD.
Common Control			
VCOM[0] VCOM[1]	Output	R4 P28	VCOM: Voltage Common Mode [1:0] These pins are used only when the receive line interface is in Receive Differential mode and connected without a transformer (transformer-less). To enable these pins, the VCOMEN pin must be connected high. Refer to Figure-10 for the connection. When these pins are not used, they should be left open.
VCOMEN	Input (Pull-Down)	AF26	VCOMEN: Voltage Common Mode Enable This pin should be connected high only when the receive line interface is in Receive Differential mode and connected without a transformer (transformer-less). When not used, this pin should be left open.
REF	-	D29	REF: Reference Resistor An external resistor (10 K Ω , $\pm 1\%$) is used to connect this pin to ground to provide a standard reference current for internal circuit. This resistor is required to ensure correct device operation.
RIM	Input (Pull-Down)	AH10	RIM: Receive Impedance Matching In Receive Differential mode, when RIM is low, all 22 receivers become High-Z and only external impedance matching is supported. In this case, the per-channel impedance matching configuration bits - the R_TERM[2:0] bits (b2~0, RCF0,...) and the R120IN bit (b4, RCF0,...) - are ignored. In Receive Differential mode, when RIM is high, impedance matching is configured on a per-channel basis by the R_TERM[2:0] bits (b2~0, RCF0,...) and the R120IN bit (b4, RCF0,...). This pin can be used to control the receive impedance state for Hitless Protection applications. Refer to Section 4.4 Hitless Protection Switching (HPS) Summary for details. In Receive Single Ended mode, this pin should be left open.
OE	Input	AJ10	OE: Output Enable OE enables or disables all Line Drivers globally. A high level on this pin enables all Line Drivers while a low level on this pin places all Line Drivers in High-Z state and independent from related register settings. Note that the functionality of the internal circuit is not affected by OE. If this pin is not used, it should be tied to VDDIO. This pin can be used to control the transmit impedance state for Hitless protection applications. Refer to Section 4.4 Hitless Protection Switching (HPS) Summary for details.

Name	I / O	Pin No.	Description
GPIO[0] GPIO[1]	Output / Input	AF9 AF10	GPIO: General Purpose I/O [1:0] These two pins can be defined as input pins or output pins by the DIR[1:0] bits (b1~0, GPIO) respectively. When the pins are input, their polarities are indicated by the LEVEL[1:0] bits (b3~2, GPIO) respectively. When the pins are output, their polarities are controlled by the LEVEL[1:0] bits (b3~2, GPIO) respectively.
$\overline{\text{RST}}$	Input	AG10	$\overline{\text{RST}}$: Reset (Active Low) A low pulse on this pin resets the device. This hardware reset process completes in 2 μs maximum. Refer to Section 4.1 Reset for an overview on reset options.
MCU Interface			
$\overline{\text{INT}}$	Output	AK16	$\overline{\text{INT}}$: Interrupt Request This pin indicates interrupt requests for all unmasked interrupt sources. The output characteristics (open drain or push-pull internally) and the active level are determined by the INT_PIN[1:0] bits (b3~2, GCF).
$\overline{\text{CS}}$	Input	AJ17	$\overline{\text{CS}}$: Chip Select (Active Low) This pin must be asserted low to enable the microprocessor interface. A transition from high to low must occur on this pin for each Read/Write operation and $\overline{\text{CS}}$ should remain low until the operation is over.
$\text{P}/\overline{\text{S}}$	Input	AG16	$\text{P}/\overline{\text{S}}$: Parallel or Serial Microprocessor Interface Select $\text{P}/\overline{\text{S}}$ selects Serial or Parallel microprocessor interface for the device: GNDD - Serial microprocessor interface. VDDIO - Parallel microprocessor interface. Serial microprocessor interface consists of the $\overline{\text{CS}}$, SCLK, SDI, SDO pins. Parallel microprocessor interface consists of the $\overline{\text{CS}}$, INT/MOT, IM, $\overline{\text{DS}}/\overline{\text{RD}}$, ALE/AS, $\overline{\text{R}}/\overline{\text{W}}/\overline{\text{WR}}$, $\overline{\text{ACK}}/\overline{\text{RDY}}$, D[7:0], A[10:0] pins.
INT/ $\overline{\text{MOT}}$	Input (Pull-Up)	AF14	INT/$\overline{\text{MOT}}$: Intel or Motorola Microprocessor Interface Select In Parallel microprocessor interface, INT/ $\overline{\text{MOT}}$ selects Intel or Motorola microprocessor interface for the device: GNDD - Parallel Motorola microprocessor interface. Open - Parallel Intel microprocessor interface. In Serial microprocessor interface, this pin should be left open.
IM	Input (Pull-Up)	AF15	IM: Interface Mode Selection In Parallel Motorola or Intel microprocessor interface, IM selects multiplexed bus or non-multiplexed bus for the device: GNDD - Parallel Motorola /Intel Non-Multiplexed microprocessor interface. Open - Parallel Motorola /Intel Multiplexed microprocessor interface. In Serial microprocessor interface, this pin should be connected to GNDD.
ALE / AS	Input	AG15	ALE: Address Latch Enable In Parallel Intel Multiplexed microprocessor interface, this multiplex pin is used as ALE. The address on A[10:8] and D[7:0] (A[7:0] are ignored) is sampled into the device on the falling edges of ALE. AS: Address Strobe In Parallel Motorola Multiplexed microprocessor interface, this multiplex pin is used as AS. The address on A[10:8] and D[7:0] (A[7:0] are ignored) is latched into the device on the falling edges of AS. In Parallel Motorola /Intel Non-Multiplexed microprocessor interface, this pin should be pulled high. In Serial microprocessor interface, this pin should be connected to GNDD.

Name	I / O	Pin No.	Description
SCLK / \overline{DS} / \overline{RD}	Input	AK17	<p>SCLK: Shift Clock In Serial microprocessor interface, this multiplex pin is used as SCLK. SCLK inputs the shift clock for the Serial microprocessor interface. Data on SDI is sampled by the device on the rising edge of SCLK. Data on SDO is updated on the falling edge of SCLK.</p> <p>\overline{DS}: Data Strobe (Active Low) In Parallel Motorola microprocessor interface, this multiplex pin is used as \overline{DS}. During a write operation ($R/\overline{W} = 0$), data on D[7:0] is sampled into the device. During a read operation ($R/\overline{W} = 1$), data is driven to D[7:0] by the device.</p> <p>\overline{RD}: Read Strobe (Active Low) In Parallel Intel microprocessor interface, this multiplex pin is used as \overline{RD}. \overline{RD} is asserted low by the microprocessor to initiate a read operation. Data is driven to D[7:0] by the device during the read operation.</p>
SDI / R/\overline{W} / \overline{WR}	Input	AH16	<p>SDI: Serial Data Input In Serial microprocessor interface, this multiplex pin is used as SDI. Address and data on this pin are serially clocked into the device on the rising edge of SCLK.</p> <p>R/\overline{W}: Read / Write Select In Parallel Motorola microprocessor interface, this multiplex pin is used as R/\overline{W}. R/\overline{W} is asserted low for write operation or high for read operation.</p> <p>\overline{WR}: Write Strobe (Active Low) In Parallel Intel microprocessor interface, this multiplex pin is used as \overline{WR}. \overline{WR} is asserted low by the microprocessor to initiate a write operation. Data on D[7:0] is sampled into the device during a write operation.</p>
SDO / \overline{ACK} / RDY	Output	AJ16	<p>SDO: Serial Data Output In Serial microprocessor interface, this multiplex pin is used as SDO. Data on this pin is serially clocked out of the device on the falling edge of SCLK.</p> <p>\overline{ACK}: Acknowledge Output (Active Low) In Parallel Motorola microprocessor interface, this multiplex pin is used as \overline{ACK}. A low level on \overline{ACK} indicates that valid information on the data bus is ready for a read operation or acknowledges the acceptance of the written data during a write operation.</p> <p>RDY: Ready Output In Parallel Intel microprocessor interface, this multiplex pin is used as RDY. A high level on RDY reports to the microprocessor that a read/write cycle can be completed. A low level on RDY reports that wait states must be inserted.</p>
D[0] D[1] D[2] D[3] D[4] D[5] D[6] D[7]	Output / Input	AG12 AH12 AJ12 AK12 AG11 AH11 AJ11 AK11	<p>D[7:0]: Bi-directional Data Bus In Parallel Motorola /Intel Non-Multiplexed microprocessor interface, these pins are the bi-directional data bus of the microprocessor interface. In Parallel Motorola /Intel Multiplexed microprocessor interface, these pins are the multiplexed bi-directional address /data bus. In Serial microprocessor interface, these pins should be connected to GNDD.</p>

Name	I / O	Pin No.	Description
A[0] A[1] A[2] A[3] A[4] A[5] A[6] A[7] A[8] A[9] A[10]	Input	AH15 AJ15 AK15 AG14 AH14 AJ14 AK14 AG13 AH13 AJ13 AK13	A[10:0]: Address Bus In Parallel Motorola /Intel Non-Multiplexed microprocessor interface, these pins are the address bus of the microprocessor interface. In Parallel Motorola /Intel Multiplexed microprocessor interface, A[10:8], together with D[7:0], are the address bus; while A[7:0] should be connected to GNDD. In Serial microprocessor interface, these pins should be connected to GNDD.
JTAG (per IEEE 1149.1)			
$\overline{\text{TRST}}$	Input Pull-Down	AF4	$\overline{\text{TRST}}$: JTAG Test Reset (Active Low) A low signal on this pin resets the JTAG test port. To ensure deterministic operation of the test logic, TMS should be held high when the signal on $\overline{\text{TRST}}$ changes from low to high. This pin may be left unconnected when JTAG is not used. This pin has an internal pull-down resistor.
TMS	Input Pull-up	AE5	TMS: JTAG Test Mode Select The signal on this pin controls the JTAG test performance and is sampled on the rising edge of TCK. To ensure deterministic operation of the test logic, TMS should be held high when the signal on $\overline{\text{TRST}}$ changes from low to high. This pin may be left unconnected when JTAG is not used. This pin has an internal pull-up resistor.
TCK	Input	AF6	TCK: JTAG Test Clock The clock for the JTAG test is input on this pin. TDI and TMS are sampled on the rising edge of TCK and TDO is updated on the falling edge of TCK. When TCK is idle at low state, all stored-state devices contained in the test logic shall retain their state indefinitely. This pin should be connected to GNDD when JTAG is not used.
TDI	Input Pull-up	AF5	TDI: JTAG Test Data Input The test data is input on this pin. It is clocked into the device on the rising edge of TCK. This pin has an internal pull-up resistor. This pin may be left unconnected when JTAG is not used.
TDO	Output	AF7	TDO: JTAG Test Data Output The test data is output on this pin. It is clocked out of the device on the falling edge of TCK. TDO is a High-Z output signal except during the process of data scanning.
Power & Ground			
VDDIO		E7, E8, E10, E11, E12, E21, E22, E23, E24, E25, AE9, AE10, AE15, AE16, AE17, AE18, AE22, AE23, AE24	VDDIO: 3.3 V I/O Power Supply
VDDA		A2, B2, J26, K27, L4, L27, M4, M26, T4, W4, Y5, Y27, Y28, AA27, AA28, AD5, AJ2, AK2	VDDA: 3.3 V Analog Core Power Supply
VDDD		E14, E15, E16, E17, E18, E19, AE11, AE14, AE19, AE20, AE21	VDDD: 1.8 V Digital Core Power Supply
VDDRn (N=0~21)		N4, N5, T5, U5, AB4, AC5, AF28, AF27, AD27, U27, T27, R27, N26, G27, E26, E27, E5, E4, F3, F5, G3, H3	VDDRn: 3.3 V Power Supply for Receiver

Name	I / O	Pin No.	Description
VDDTn (N=0~21)		K2, L2, P2, R3, W2, Y2, AF29, AC29, AA29, Y29, R29, P29, K29, J29, F29, E29, C6, C4, C3, C2, F2, H2	VDDTn: 3.3 V Power Supply for Transmitter Driver
GND A		A1, A29, A30, B1, B29, B30, F6, F7, F8, F25, G6, G25, H6, H25, J6, J25, K6, K25, L6, L25, M6, M25, N6, N25, P6, P25, R6, R25, T6, T25, U6, U25, V6, V25, W6, W25, W26, Y6, Y25, AA6, AA25, AB1, AB6, AB25, AB26, AC6, AC25, AC26, AD6, AD25, AE6, AE25, AJ1, AJ29, AJ30, AK1, AK29, AK30	GND A: GND for Analog Core / Receiver
GND D		F10, F11, F12, F13, F14, F15, F16, F17, F18, F19, F20, F21, F22, F23, F24, M12, M13, M14, M15, M16, M17, M18, M19, N12, N13, N14, N15, N16, N17, N18, N19, P12, P13, P14, P15, P16, P17, P18, P19, R12, R13, R14, R15, R16, R17, R18, R19, T12, T13, T14, T15, T16, T17, T18, T19, U12, U13, U14, U15, U16, U17, U18, U19, V12, V13, V14, V15, V16, V17, V18, V19, W12, W13, W14, W15, W16, W17, W18, W19, AE7, AE8, AE12, AE13, AF23, AF24	GND D: Digital GND
GND T		B5, B6, C5, D2, D28, E2, H28, H29, J3, J5, J28, K3, K5, L3, M3, M28, N28, N29, T2, U2, U28, V28, V29, W29, AA3, AB2, AB28, AD29, AE29	GND T: Analog GND for Transmitter Driver
TEST			
IC	-	AF13, AF12	IC: Internal Connected This pin is for IDT use only and should be connected to GND D.
IC	-	AH18, AF11	IC: Internal Connected This pin is for IDT use only and should be left open.

Name	I/O	Pin No.	Description
Others			
NC	-	A8, A9, A21, A25, A26, B9, B21, B25, B26, C9, C21, C22, C26, C28, C29, D7, D9, D10, D16, D21, D22, D26, E9, E13, E20, F9, F27, G1, G2, G28, G29, G30, H1, H4, H26, H27, J4, J27, K4, L29, M27, M29, M30, N1, N2, N27, P1, P4, P27, T3, T26, T29, U3, U26, U29, U30, V1, V2, V3, V26, V27, W3, Y3, AB3, AB27, AB29, AB30, AC27, AC28, AD3, AD4, AE1, AE2, AE3, AE4, AE27, AF8, AF16, AF25, AG4, AG22, AG26, AG27, AG30, AH4, AH5, AH22, AH23, AH27, AJ4, AJ5, AJ22, AJ23, AJ27, AK5, AK23, AK27, AK28	NC: Not Connected

3 FUNCTIONAL DESCRIPTION

3.1 RECEIVE PATH

3.1.1 R_x TERMINATION

The receive line interface supports Receive Differential mode and Receive Single Ended mode, as selected by the R_SING bit (b3, RCF0,...). In Receive Differential mode, both RTIP_n and RRING_n are used to receive signal from the line side. In Receive Single Ended mode, only RTIP_n is used to receive signal.

In Receive Differential mode, the line interface can be connected with E1 120 Ω twisted pair cable or E1 75 Ω coaxial cable. In Receiver Single Ended mode, the line interface can only be connected with 75 Ω coaxial cable.

The receive impedance matching is realized by using internal impedance matching or external impedance matching for each channel in different applications.

3.1.1.1 Receive Differential Mode

In Receive Differential mode, three kinds of impedance matching are supported: Fully Internal Impedance Matching, Partially Internal Impedance Matching and External Impedance Matching. Figure-7 shows an overview of how these Impedance Matching modes are switched.

Fully Internal Impedance Matching circuit uses an internal programmable resistor (IM) only and does not use an external resistor. This configuration saves external components and supports 1:1 Hitless Protection Switching (HPS) applications without relays. Refer to Section 4.4 Hitless Protection Switching (HPS) Summary.

Partially Internal Impedance Matching circuit consists of an internal programmable resistor (IM) and a value-fixed 120 Ω external resistor (R_r). Compared with Fully Internal Impedance Matching, this configuration provides considerable savings in power dissipation of the device. For example, In E1 120 Ω PRBS mode, the power savings would be 0.57 W. For power savings in other modes, please refer to Chapter 8 Physical And Electrical Specifications.

External Impedance Matching circuit uses an external resistor (R_r) only.

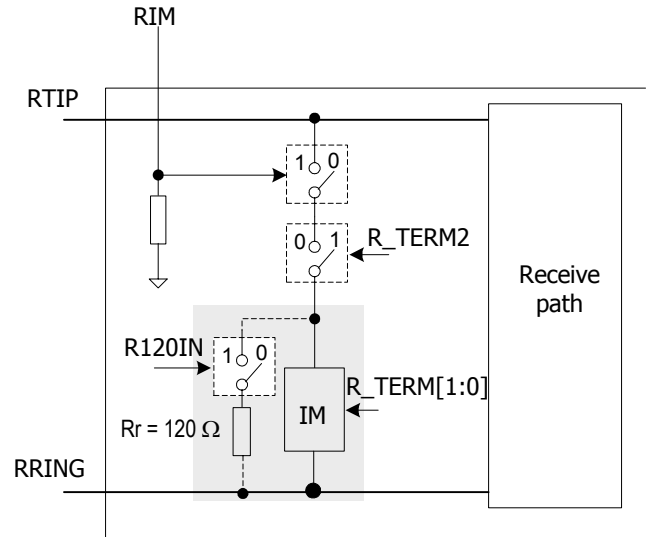

Figure-7 Switch between Impedance Matching Modes

To support some particular applications, such as hot-swap or Hitless Protection Switch (HPS) hot-switchover, RTIP_n/RRING_n must be forced to enter high impedance state (i.e., External Impedance Matching). For hot-swap, RTIP_n/RRING_n must be always held in high impedance state during /after power up; for HPS hot-switchover, RTIP_n/RRING_n must enter high impedance state immediately after switchover. Though each channel can be individually configured to External Impedance Matching through register access, it is too slow for hitless switch. Therefore, a hardware pin - RIM - is provided to globally control the high impedance for all 22 receivers.

When RIM is low, only External Impedance Matching is supported for all 22 receivers and the per-channel impedance matching configuration bits - the R_TERM[2:0] bits (b2~0, RCF0,...) and the R120IN bit (b4, RCF0,...) - are ignored.

When RIM is high, impedance matching is configured on a per-channel basis. Three kinds of impedance matching are all supported and selected by the R_TERM[2:0] bits (b2~0, RCF0,...) and the R120IN bit (b4, RCF0,...). The R_TERM[2] bit (b2, RCF0,...) should be set to match internal or external impedance. If the R_TERM[2] bit (b2, RCF0,...) is '0', internal impedance matching is enabled. The R120IN bit (b4, RCF0,...) should be set to select Partially Internal Impedance Matching or Fully Internal Impedance Matching. The internal programmable resistor (IM) is determined by the R_TERM[1:0] bits (b1~0, RCF0,...). If the R_TERM[2] bit (b2, RCF0,...) is '1', external impedance matching is enabled. The configuration of the R120IN bit (b4, RCF0,...) and the R_TERM[1:0] bits (b1~0, RCF0,...) is ignored.

A twisted pair cable can be connected with a 1:1 transformer or without a transformer (transformer-less), while a coaxial cable must be connected with a 1:1 transformer. Table 1 lists the recommended impedance matching value in different applications. Figure-8 to Figure-10 show the connection for one channel.

The transformer-less connection will offer a termination option with reduced cost and board space. However, the waveform amplitude is not standard compliant, and surge protection and common mode depression should be enhanced depending on equipment environment.

Table-1 Impedance Matching Value in Receive Differential Mode

Cable Condition	Partially Internal Impedance Matching (R120IN = 0) ¹		Fully Internal Impedance Matching (R120IN = 1) ^{1,2}		External Impedance Matching	
	R_TERM[2:0]	Rr	R_TERM[2:0]	Rr	R_TERM[2:0] ³	Rr
E1 120 Ω twisted pair (with transformer)	010	120 Ω	010	(open)	1XX	120 Ω
E1 75 Ω coaxial (with transformer)	011		011			75 Ω
E1 120 Ω twisted pair (transformer-less ⁴)	010		(not supported)			120 Ω

Note:

- Partially Internal Impedance Matching and Fully Internal Impedance Matching are not supported when RIM is low.
- Fully Internal Impedance Matching is not supported in transformer-less applications.
- When RIM is low, the setting of the R_TERM[2:0] bits is ignored.
- In transformer-less applications, the device should be protected against overvoltage. There are three important standards for overvoltage protection:
 - UL1950 and FCC Part 68;
 - Telcordia (Bellcore) GR-1089
 - ITU-T K.20, K.21 and K.41

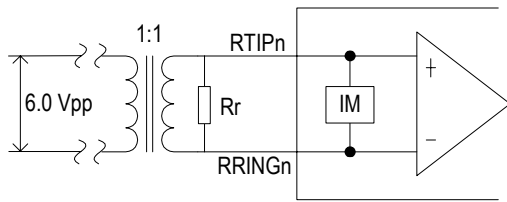
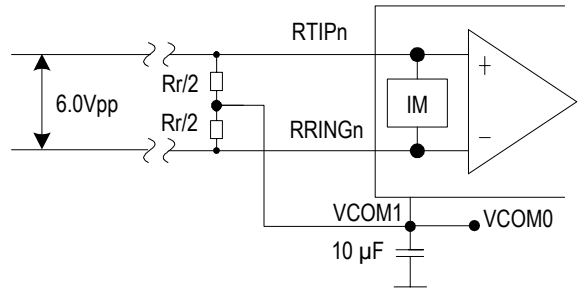

Figure-8 Receive Differential Line Interface with Twisted Pair Cable (with transformer)



- Note:**
- Two Rr/2 resistors should be connected to VCOM[1:0] that are coupled to ground via a 10 μF capacitor, which provide 60 Ω common mode input resistance.
 - In this mode, lightning protection should be enhanced.
 - The maximum input dynamic range of RTIP/TRING pin is -0.3 V ~3.6 V (in line monitor mode it is -0.3 V ~ 2 V)

Figure-10 Receive Differential Line Interface with Twisted Pair Cable (transformer-less, non standard compliant)

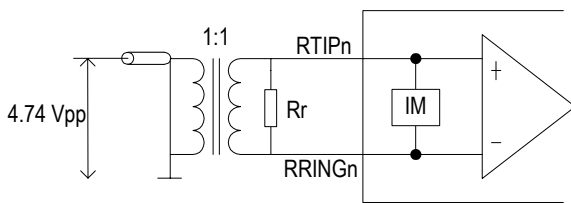

Figure-9 Receive Differential Line Interface with Coaxial Cable (with transformer)

3.1.1.2 Receive Single Ended Mode

Receive Single Ended mode can only be used in 75 Ω coaxial cable applications.

In Receive Single Ended mode, only External Impedance Matching is supported. External Impedance Matching circuit uses an external resistor (Rr) only. The value of the resistor is 18.75 Ω (see Figure-11 for details) when the single end is connected with a 2:1 transformer or is 75 Ω (see Figure-12 for details) when the single end is connected without a transformer.

In Receive Single Ended mode, the RIM pin should be left open and the configuration of the R_TERM[2:0] bits (b2~0, RCF0,...) is ignored.

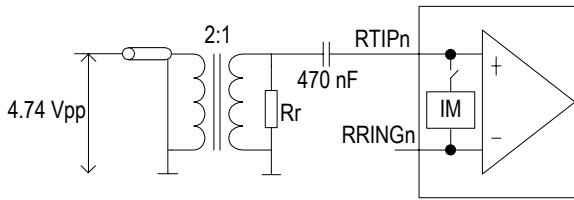
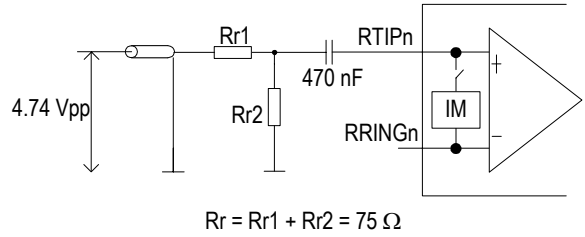

Figure-11 Receive Single Ended Line Interface with Coaxial Cable (with transformer)



$$R_r = R_{r1} + R_{r2} = 75 \Omega$$

Note: In this mode, port protection should be enhanced.

Figure-12 Receive Single Ended Line Interface with Coaxial Cable (transformer-less, non standard compliant)

3.1.2 EQUALIZER

The equalizer compensates high frequency attenuation to enhance receive sensitivity.

3.1.2.1 Line Monitor

In E1 short haul applications, the Protected Non-Intrusive Monitoring per T1.102 can be performed between two devices. The monitored channel of one device is in normal operation, and the monitoring channel of the other device taps the monitored one through a high impedance bridging circuit (refer to Figure-13 and Figure-14).

After the high resistance bridging circuit, the signal arriving at RTIPn/RRINGn of the monitoring channel is dramatically attenuated. To compensate this bridge resistive attenuation, Monitor Gain can be used to boost the signal by 20 dB, 26 dB or 32 dB, as selected by the MG[1:0] bits (b1~0, RCF2,...). For normal operation, the Monitor Gain should be set to 0 dB, i.e., the Monitor Gain of the monitored channel should be 0 dB.

The monitoring channel can be configured to any of the External, Partially Internal or Fully Internal Impedance Matching mode. Here the external r or internal IM is used for voltage division, not for impedance matching. That is, the r (IM) and the two R make up of a resistance bridge. The resistive attenuation of this bridge is $20\lg(r/(2R+r))$ dB.

Note that line monitor is only available in differential line interface.

A channel 0 monitoring function is provided (refer to Section 3.4.9 Channel 0 Monitoring). If multiple High-Density LIUs are used in an application, The G.772 function of channel 0 can be used to route the signals of channel 1~21 Receive and Transmit to channel 0 of the same device. This channel 0 Transmit TTIP and TTRING could then be monitored by another device through the Line Monitor function.

3.1.2.2 Receive Sensitivity

The receive sensitivity is the minimum range of receive signal level for which the receiver recovers data error-free with -18 dB interference signal added.

For Receive Differential line interface, the receive sensitivity is -15 dB.

For Receive Single Ended line interface, the receive sensitivity is -12 dB.

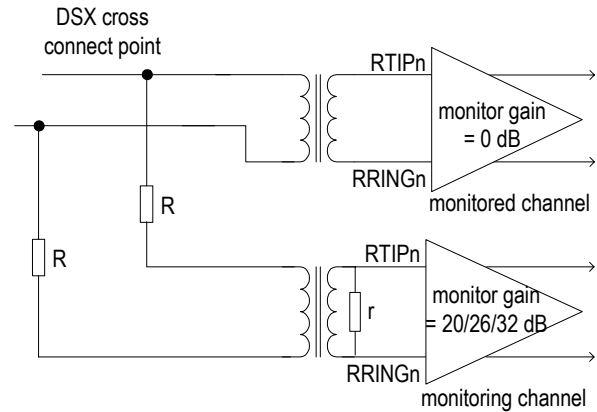

Figure-13 Receive Path Monitoring

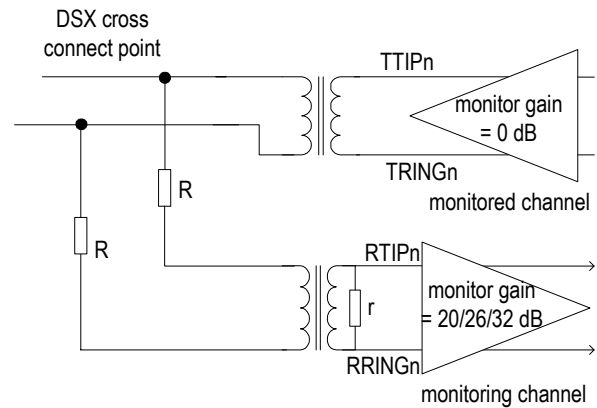

Figure-14 Transmit Path Monitoring

3.1.3 SLICER

The Slicer is used to generate a standard amplitude mark or a space according to the amplitude of the input signals. The input signal is sliced at 50% of the peak value.

3.1.4 R_x CLOCK & DATA RECOVERY

The Rx Clock & Data Recovery is used to recover the clock signal from the received data. It is accomplished by an integrated Digital Phase Locked Loop (DPLL). The recovered clock tracks the jitter in the data output from the Slicer and keeps the phase relationship between data and clock during the absence of the incoming pulse.

Note that the IDT82P2521 also provides programmable REFA and REFB pins to output any of the 22 recovered line clocks. Refer to Section 3.5 Clock Inputs and Outputs for details.

3.1.5 DECODER

The Decoder is used only when the receive system interface is in Single Rail NRZ Format mode. When the receive system interface is in other modes, the Decoder is bypassed automatically. (Refer to Section 3.1.6 Receive System Interface for the description of the receive system interface).

The received signal is decoded by AMI or HDB3 line code rule. The line code rule is selected by the R_CODE bit (b2, RCF1,...).

3.1.6 RECEIVE SYSTEM INTERFACE

The received data can be output to the system side in four modes: Single Rail NRZ Format mode, Dual Rail NRZ Format mode, Dual Rail RZ Format mode and Dual Rail Sliced mode, as selected by the R_MD[1:0] bits (b1~0, RCF1).

If data is output on RD_n in NRZ format and the recovered clock is output on RCLK_n, the receive system interface is in Single Rail NRZ Format mode. In this mode, the data is decoded and updated on the active edge of RCLK_n. RCLK_n outputs a 2.048 MHz clock. The Receive Multiplex Function (RMF_n) signal is updated on the active edge of RCLK_n and can be selected to indicate PRBS/ARB, LAIS, LEXZ, LBPV, LEXZ + LBPV, LLOS, output recovered clock (RCLK) or XOR output of positive and negative sliced data. Refer to Section 3.4.7.1 RMF_n Indication for the description of RMF_n.

If data is output on RDP_n and RDN_n in NRZ format and the recovered clock is output on RCLK_n, the receive system interface is in Dual Rail NRZ Format mode. In this mode, the data is un-decoded and updated on the active edge of RCLK_n. RCLK_n outputs a 2.048 MHz clock.

If data is output on RDP_n and RDN_n in RZ format and the recovered clock is output on RCLK_n, the receive system interface is in Dual Rail RZ Format mode. In this mode, the data is un-decoded and updated on the active edge of RCLK_n. RCLK_n outputs a 2.048 MHz clock.

If data is output on RDP_n and RDN_n in RZ format directly after passing through the Slicer, the receive system interface is in Dual Rail Sliced mode. In this mode, the data is raw sliced and un-decoded. RMF_n can be selected to indicate PRBS/ARB, LAIS, LEXZ, LBPV, LEXZ + LBPV, LLOS, output recovered clock (RCLK) or XOR output of positive and negative sliced data. Refer to Chapter 3.4.7.1 RMF_n Indication for the description of RMF_n.

Table-2 summarizes the multiplex pin used in different receive system interface.

Table-2 Multiplex Pin Used in Receive System Interface

Receive System Interface	Multiplex Pin Used On Receive System Interface		
	RD _n / RDP _n	RDN _n / RMF _n	RCLK _n / RMF _n
Single Rail NRZ Format	RD _n ¹	RMF _n ²	RCLK _n ³
Dual Rail NRZ Format	RDP _n ¹	RDN _n ¹	RCLK _n ³
Dual Rail RZ Format	RDP _n ¹	RDN _n ¹	RCLK _n ³
Dual Rail Sliced	RDP _n ¹	RDN _n ¹	RMF _n ²
Note: 1. The active level on RD _n , RDP _n and RDN _n is selected by the RD_INV bit (b3, RCF1,...). 2. RMF _n is always active high. 3. The active edge of RCLK _n is selected by the RCK_ES bit (b4, RCF1,...).			

3.1.7 RECEIVER POWER DOWN

Set the R_OFF bit (b5, RCF0,...) to '1' will power down the corresponding receiver.

In this way, the corresponding receive circuit is turned off and the RTIPn/RRINGn pins are forced to High-Z state. The pins on receive system interface (including RDn/RDPn, RDNn/RMFn, RCLKn/RMFn) will be in High-Z state if the RHZ bit (b6, RCF0,...) is '1' or in low level if the RHZ bit (b6, RCF0,...) is '0'.

After clearing the R_OFF bit (b5, RCF0,...), it will take 1 ms for the receiver to achieve steady state, i.e., to return to the previous configuration and performance.

3.2 TRANSMIT PATH

3.2.1 TRANSMIT SYSTEM INTERFACE

The data from the system side is input to the device in three modes: Single Rail NRZ Format mode, Dual Rail NRZ Format mode and Dual Rail RZ Format mode, as selected by the T_MD[1:0] bits (b1~0, TCF1,...).

If data is input on TDn in NRZ format and a 2.048 MHz clock is input on TCLKn, the transmit system interface is in Single Rail NRZ Format mode. In this mode, the data is encoded and sampled on the active edge of TCLKn. TMFn is updated on the active edge of TCLKn and can be selected to indicate PRBS/ARB, SAIS, TOC, TLOS or SEXZ. Refer to Section 3.4.7.2 TMFn Indication for the description of TMFn.

If data is input on TDPn and TDNn in NRZ format and a 2.048 MHz clock is input on TCLKn, the transmit system interface is in Dual Rail NRZ Format mode. In this mode, the data is pre-encoded and sampled on the active edge of TCLKn.

If data is input on TDPn and TDNn in RZ format and no transmit clock is input, the transmit system interface is in Dual Rail RZ Format mode. In this mode, the data is pre-encoded. TMFn can be selected to indicate PRBS/ARB, SAIS, TOC, TLOS, SEXZ, SBPV, SEXZ + SBPV or SLOS. Refer to Section 3.4.7.2 TMFn Indication for the description of TMFn. The Tx Clock Recovery block is used to recover the clock signal from the data input on TDPn and TDNn. Refer to Section 3.2.2 Tx Clock Recovery.

Table-3 summarizes the multiplex pin used in different transmit system interface.

Table-3 Multiplex Pin Used in Transmit System Interface

Transmit System Interface	Multiplex Pin Used On Transmit System Interface		
	TDn / TDPn	TDNn / TMFn	TCLKn / TDNn
Single Rail NRZ Format	TDn ¹	TMFn ²	TCLKn ³
Dual Rail NRZ Format	TDPn ¹	TDNn ¹	TCLKn ³
Dual Rail RZ Format	TDPn ¹	TMFn ²	TDNn ¹

Note:
 1. The active level on TDn, TDPn and TDNn is selected by the TD_INV bit (b3, TCF1,...).
 2. TMFn is always active high.
 3. The active edge of TCLKn is selected by the TCK_ES bit (b4, TCF1,...). If TCLKn is missing, i.e., no transition for more than 64 E1 clock cycles, the TCKLOS_S bit (b3, STAT0,...) will be set. A transition from '0' to '1' on the TCKLOS_S bit (b3, STAT0,...) or any transition (from '0' to '1' or from '1' to '0') on the TCKLOS_S bit (b3, STAT0,...) will set the TCKLOS_IS bit (b3, INTS0,...) to '1', as selected by the TCKLOS_IES bit (b3, INTES,...). When the TCKLOS_IS bit (b3, INTS0,...) is '1', an interrupt will be reported by INT if not masked by the TCKLOS_IM bit (b3, INTM0,...).

3.2.2 Tx CLOCK RECOVERY

The Tx Clock Recovery is used only when the transmit system interface is in Dual Rail RZ Format mode. When the transmit system interface is in other modes, the Tx Clock Recovery is bypassed automatically.

The Tx Clock Recovery is used to recover the clock signal from the data input on TDPn and TDNn.

3.2.3 ENCODER

The Encoder is used only when the transmit system interface is in Single Rail NRZ Format mode. When the transmit system interface is in other modes, the Encoder is bypassed automatically.

The data to be transmitted is encoded by AMI or HDB3 line code rule. The line code rule is selected by the T_CODE bit (b2, TCF1,...).

3.2.4 WAVEFORM SHAPER

The IDT82P2521 provides two ways to manipulate the pulse shape before data is transmitted:

- Preset Waveform Template;
- User-Programmable Arbitrary Waveform.

3.2.4.1 Preset Waveform Template

The waveform template meets G.703, as shown in Figure-15. It is measured in the near end line side, as shown in Figure-16.

The PULS[3:0] should be set to '0000' if differential signals (output from TTIP and TRING) are coupled to a 75 Ω coaxial cable using Internal Impedance matching mode; the PULS[3:0] should be set to '0001' for other E1 interfaces. Refer to Table-4 for details.

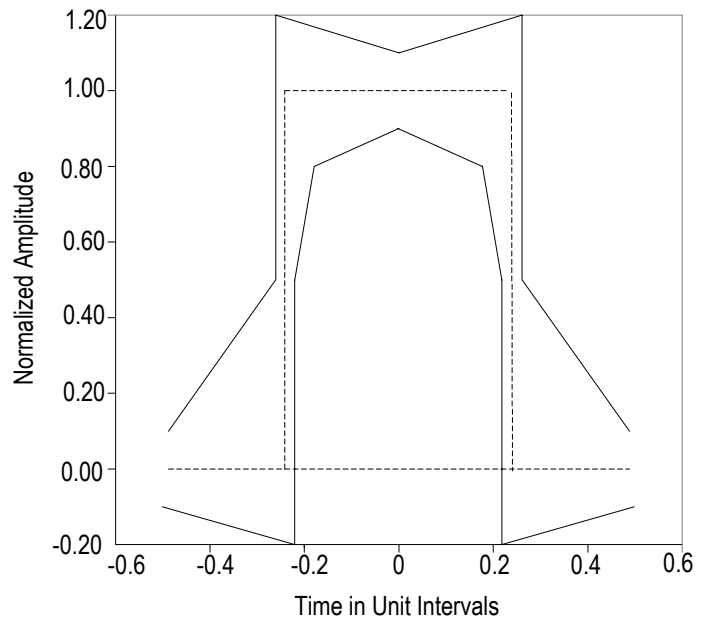

Figure-15 E1 Waveform Template

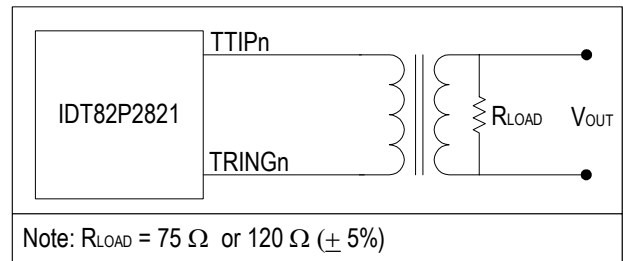

Figure-16 E1 Waveform Template Measurement Circuit

Table-4 PULS[3:0] Setting

Interface Conditions	PULS[3:0]
E1 75 Ω differential interface, Internal Impedance matching mode	0000
Other E1 interface	0001

After one of the preset waveform templates is selected, the preset waveform amplitude can be adjusted to get the desired waveform.

The SCAL[5:0] bits (b5~0, SCAL,...) should be set to '100001' to get the standard amplitude. The adjusting is made by increasing or decreasing by '1' from the standard value to scale up or down at a percentage ratio of 3%.

In summary, do the following step by step, the desired waveform will be got based on the preset waveform template:

- Select one preset waveform template by setting the PULS[3:0] bits (b3~0, PULS,...);
- Write '100001' to the SCAL[5:0] bits (b5~0, SCAL,...).
- Write the scaling value to the SCAL[5:0] bits (b5~0, SCAL,...) to scale the amplitude of the selected preset waveform template (- this step is optional).

3.2.4.2 User-Programmable Arbitrary Waveform

When the PULS[3:0] bits (b3~0, PULS,...) are set to '1XXX', user-programmable arbitrary waveform will be used in the corresponding channel.

Each waveform shape can extend up to $1\frac{1}{4}$ UIs (Unit Interval), and is divided into 20 sub-phases that are addressed by the SAMP[4:0] bits (b4~0, AWG0,...). The waveform amplitude of each phase is represented by a binary byte, within the range from +63 to -63, stored in the WDAT[6:0] bits (b6~0, AWG1,...) in signed magnitude form. The maximum number +63 (D) represents the maximum positive amplitude of the transmit pulse while the most negative number -63 (D) represents the maximum negative amplitude of the transmit pulse. Therefore, up to 20 bytes are used.

There are eight standard templates which are stored in a local ROM. One of them can be selected as reference and made some changes to get the desired waveform.

To do this, the first step is to choose a set of waveform value from the standard templates. The selected waveform value should be the most similar to the desired waveform shape. Table-5 and Table-6 list the sample data of each template.

Then modify the sample data to get the desired transmit waveform shape. By increasing or decreasing by '1' from the standard value in the SCAL[5:0] bits (b5~0, SCAL,...), the waveform amplitude will be scaled up or down.

In summary, do the following for the write operation:

- Modify the sample data in the AWG1 register;
- Write the AWG0 register to implement the write operation, including:
 - Write the sample address to the SAMP[4:0] bits (b4~0, AWG0,...);
 - Write '0' to the RW bit (b5, AWG0,...);
 - Write '1' to the DONE bit (b6, AWG0,...).

Do the following for the read operation:

- Write the AWG0 register, including:
 - Write sample address to the SAMP[4:0] bits (b4~0, AWG0,...);
 - Write '1' to the RW bit (b5, AWG0,...);
 - Write '1' to the DONE bit (b6, AWG0,...);
- Read the AWG1 register to get the sample data.

When the write operation is completed, write the scaling value to the SCAL[5:0] bits (b5~0, SCAL,...) to scale the amplitude of the selected standard waveform (- this step is optional).

When more than one UI is used to compose the waveform template and the waveform amplitude is not set properly, the overlap of the two consecutive waveforms will make the waveform amplitude overflow (i.e., exceed the maximum limitation). This overflow is captured by the DAC_IS bit (b7, INTS0,...) and will be reported by the $\overline{\text{INT}}$ pin if enabled by the DAC_IM bit (b7, INTM0,...).

Refer to application note AN-513 'User-Programmable Arbitrary Waveform for DSX1' for more details.

Table-5 Transmit Waveform Value for E1 75 ohm

SAMP[4:0]	1	2	3	4	5	6	7	8	9	10	11	12	13	14	15	16	17	18	19	20
WDAT[6:0]	00H	00H	00H	0CH	30H	30H	30H	30H	30H	30H	30H	30H	00H	00H	00H	00H	00H	00H	00H	00H

Table-6 Transmit Waveform Value for E1 120 ohm

SAMP[4:0]	1	2	3	4	5	6	7	8	9	10	11	12	13	14	15	16	17	18	19	20
WDAT[6:0]	00H	00H	00H	0FH	3CH	3CH	3CH	3CH	3CH	3CH	3CH	3CH	00H	00H	00H	00H	00H	00H	00H	00H

3.2.5 LINE DRIVER

The Line Driver can be set to High-Z for protection or in redundant applications.

The following two ways will set the Line Driver to High-Z:

- Setting the OE pin to low will globally set all the Line Drivers to High-Z;
- Setting the OE bit (b6, TCF0,...) to '0' will set the corresponding Line Driver to High-Z.

By these ways, the functionality of the internal circuit is not affected and TTIPn and TRINGn will enter High-Z state immediately.

3.2.5.1 Transmit Over Current Protection

The Line Driver monitors the Transmit Over Current (TOC) on the line interface. When TOC is detected, the driver's output (i.e., output on TTIPn/TRINGn) is determined by the THZ_OC bit (b4, TCF0,...). If the THZ_OC bit (b4, TCF0,...) is '0', the driver's output current (peak to peak) is limited to 100 mA; if the THZ_OC bit (b4, TCF0,...) is '1', the driver's output will enter High-Z. TOC is indicated by the TOC_S bit (b4, STAT0,...). A transition from '0' to '1' on the TOC_S bit (b4, STAT0,...) or any transition (from '0' to '1' or from '1' to '0') on the TOC_S bit (b4, STAT0,...) will set the TOC_IS bit (b4, INTS0,...) to '1', as selected by the TOC_IES bit (b4, INTES,...). When the TOC_IS bit (b4, INTS0,...) is '1', an interrupt will be reported by $\overline{\text{INT}}$ if not masked by the TOC_IM bit (b4, INTM0,...).

TOC may be indicated by the TMFn pin. Refer to Section 3.4.7.2 TMFn Indication for details.

3.2.6 T_X TERMINATION

The transmit line interface supports Transmit Differential mode and Transmit Single Ended mode, as selected by the T_SING bit (b3, TCF0,...). In Transmit Differential mode, both TTIPn and TRINGn are used to transmit signals to the line side. In Transmit Single Ended mode, only TTIPn is used to transmit signal.

The line interface can be connected with E1 120 Ω twisted pair cable or E1 75 Ω coaxial cable.

The transmit impedance matching is realized by using internal impedance matching or external impedance matching for each channel in different applications.

3.2.6.1 Transmit Differential Mode

In Transmit Differential mode, different applications have different impedance matching. For E1 applications, both Internal and External Impedance Matching are supported.

Internal Impedance Matching circuit uses an internal programmable resistor (IM) only.

External Impedance Matching circuit uses an external resistor (Rt) only.

A twisted pair cable can be connected with a 1:2 (step up) transformer or without a transformer (transformer-less), while a coaxial cable must be connected with a 1:2 transformer.

The T_TERM[2:0] bits (b2~0, TCF0,...) should be set according to different cable conditions, whether a transformer is used, and what kind of Impedance Matching is selected.

Table-7 lists the recommended impedance matching value in different applications. Figure-17 to Figure-19 show the connection for one channel in different applications.

The transformer-less connection will offer a termination option with reduced cost and board space. However, the waveform amplitude is not standard compliant, and surge protection and common mode depression should be enhanced depending on equipment environment.

Table-7 Impedance Matching Value in Transmit Differential Mode

Cable Condition	Internal Impedance Matching		External Impedance Matching	
	T_TERM[2:0]	Rt	T_TERM[2:0]	Rt
E1 120 Ω twisted pair (with transformer), PULS[3:0]=0001	010	0	111	10 Ω
E1 75 Ω coaxial (with transformer), PULS[3:0]=0000	011			
E1 120 Ω twisted pair (transformer-less), PULS[3:0]=0001	110		(not supported)	

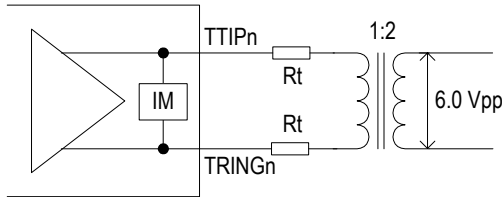

Figure-17 Transmit Differential Line Interface with Twisted Pair Cable (with Transformer)

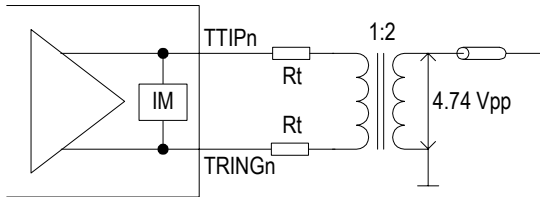
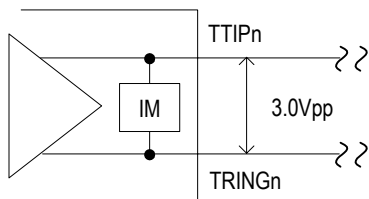

Figure-18 Transmit Differential Line Interface with Coaxial Cable (with transformer)



Note: In this mode, port protection should be enhanced.

Figure-19 Transmit Differential Line Interface with Twisted Pair Cable (transformer-less, non standard compliant)

3.2.6.2 Transmit Single Ended Mode

Transmit Single Ended mode can only be used in 75 Ω coaxial cable applications.

In Transmit Single Ended mode, only Internal Impedance Matching is supported. Internal Impedance Matching circuit uses an internal programmable resistor (IM) only. The T_TERM[2:0] bits (b2~0, TCF0,...) should be set to '011'. The output amplitude is 4.74 Vpp when PULS[3:0] is '0001' and the SCAL[5:0] bits (b5~0, SCAL,...) is '100001'.¹

In Single Ended mode, special care has to be taken for termination and overall setup. Refer to separate application note for details.

A 1:2 (step up) transformer should be used in application.

Figure-20 shows the connection for one channel.

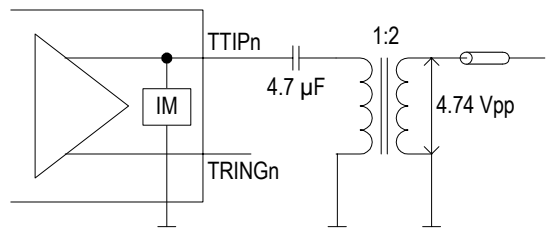

Figure-20 Transmit Single Ended Line Interface with Coaxial Cable (with transformer)

1. The waveform in this mode is not standard. However, if the arbitrary waveform generator is used, the waveform could pass the template marginally.

3.2.7 TRANSMITTER POWER DOWN

Set the T_OFF bit (b5, TCF0,...) to '1' will power down the corresponding transmitter.

In this way, the corresponding transmit circuit is turned off. The pins on the transmit line interface (including TTIPn and TRINGn) will be in High-Z state. The input on the transmit system interface (including TDn, TDPn, TDNn and TCLK) is ignored. The output on the transmit system interface (i.e. TMFn) will be in High-Z state.

After clearing the T_OFF bit (b5, TCF0,...), it will take 1 ms for the transmitter to achieve steady state, i.e., return to the previous configuration and performance.

3.2.8 OUTPUT HIGH-Z ON TTIP AND TRING

TTIPn and TRINGn can be set to High-Z state globally or on a per-channel basis.

The following three conditions will set TTIPn and TRINGn to High-Z state globally:

- Connecting the OE pin to low;
- Loss of MCLK (i.e., no transition on MCLK for more than 1 ms);
- Power on reset, hardware reset by pulling $\overline{\text{RST}}$ to low for more than 2 μs or global software reset by writing the RST register.

The following six conditions will set TTIPn and TRINGn to High-Z state on a per-channel basis:

- Writing '0' to the OE bit (b6, TCF0,...);
- Loss of TCLKn in Transmit Single Rail NRZ Format mode or Transmit Dual Rail NRZ Format mode (i.e., no transition on TCLKn for more than 64 XCLK¹ cycles) except that the channel is in Remote Loopback or transmit internal pattern with XCLK;
- Transmitter power down;
- Per-channel software reset by writing '1' to the CHRST bit (b1, CHCF,...);
- Setting the THZ_OC bit (b4, TCF0,...) to '1' when transmit driver over-current is detected.

1. XCLK is derived from MCLK. It is 2.048 MHz .

3.3 JITTER ATTENUATOR (RJA & TJA)

Two Jitter Attenuators are provided for each channel of receiver and transmitter. Each Jitter Attenuator can be enabled or disabled, as determined by the RJA_EN/TJA_EN bit (b3, RJA/TJA,...) respectively.

Each Jitter Attenuator consists of a FIFO and a DPLL, as shown in Figure-21.

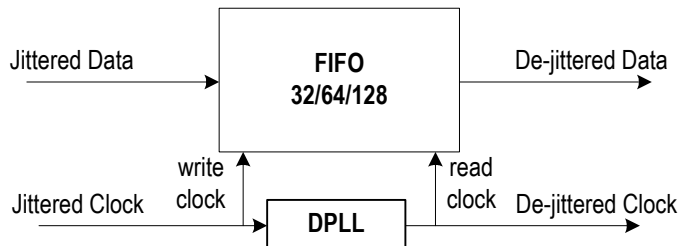

Figure-21 Jitter Attenuator

The FIFO is used as a pool to buffer the jittered input data, then the data is clocked out of the FIFO by a de-jittered clock. The depth of the FIFO can be 32 bits, 64 bits or 128 bits, as selected by the RJA_DP[1:0]/TJA_DP[1:0] bits (b2~1, RJA/TJA,...). Accordingly, the typical delay produced by the Jitter Attenuator is 16 bits, 32 bits or 64 bits. The 128-bit FIFO is used when large jitter tolerance is expected, while the 32-bit FIFO is used in delay sensitive applications.

The DPLL is used to generate a de-jittered clock to clock out the data stored in the FIFO. The DPLL can only attenuate the incoming jitter whose frequency is above Corner Frequency (CF) by 20 dB per decade falling off. The jitter whose frequency is lower than the CF passes through the DPLL without any attenuation. The CF of the DPLL is 6.77 Hz or 0.87 Hz. The CF is selected by the RJA_BW/TJA_BW bit (b0, RJA/TJA,...). The lower the CF is, the longer time is needed to achieve synchronization.

If the incoming data moves faster than the outgoing data, the FIFO will overflow. If the incoming data moves slower than the outgoing data, the FIFO will underflow. The overflow and underflow are both captured by the RJA_IS/TJA_IS bit (b5/6, INTS0,...). The occurrence of overflow or underflow will be reported by the $\overline{\text{INT}}$ pin if enabled by the RJA_IM/TJA_IM bit (b5/6, INTM0,...).

To avoid overflow or underflow, the JA-Limit function can be enabled by setting the RJA_LIMT/TJA_LIMT bit (b4, RJA/TJA,...). When the JA-Limit function is enabled, the speed of the outgoing data will be adjusted automatically if the FIFO is 2-bit close to its full or emptiness. Though the JA-Limit function can reduce the possibility of FIFO overflow and underflow, the quality of jitter attenuation is deteriorated.

The performance of the Jitter Attenuator meets ITUT I.431, G.703, G.736-739, G.823, G.824, ETSI 300011, ETSI TBR12/13, AT&T TR62411, TR43802, TR-TSY 009, TR-TSY 253 and TR-TRY 499. Refer to Section 8.10 Jitter Attenuation Characteristics for the jitter performance.

3.4 DIAGNOSTIC FACILITIES

The diagnostic facilities include:

- BPV (Bipolar Violation) / CV (Code Violation) detection and BPV insertion;
- EXZ (Excessive Zero) detection;
- LOS (Loss Of Signal) detection;
- AIS (Alarm Indication Signal) detection and generation;
- Pattern generation and detection, including PRBS (Pseudo Random Bit Sequence), ARB (Arbitrary Pattern) and IB (Inband Loopback).

The above defects, alarms or patterns can be counted by an internal Error Counter, indicated by the respective interrupt bit and indicated by RMFn or TMFn.

For diagnostic purposes, loopbacks and channel 0 monitoring can also be implemented.

3.4.1 BIPOLAR VIOLATION (BPV) / CODE VIOLATION (CV) DETECTION AND BPV INSERTION

3.4.1.1 Bipolar Violation (BPV) / Code Violation (CV) Detection

BPV/CV is monitored in both the receive path and the transmit path. BPV is detected when the data is AMI coded and CV is detected when the data is HDB3 coded. If the transmit system interface is in Transmit Single Rail NRZ Format mode, the BPV/CV detection is disabled in the transmit path automatically.

A BPV is detected when two consecutive pulses of the same polarity are received.

A CV is detected when two consecutive BPVs of the same polarity that are not a part of the HDB3 zero substitution are received.

When BPV/CV is detected in the receive path, the Line Bipolar Violation LBPV_IS bit (b4, INTS2,...) will be set and an interrupt will be reported by \overline{INT} if not masked by the LBPV_IM bit (b4, INTM2,...).

When BPV/CV is detected in the transmit path, the System Bipolar Violation SBPV_IS bit (b5, INTS2,...) will be set and an interrupt will be reported by \overline{INT} if not masked by the SBPV_IM bit (b5, INTM2,...).

BPV/CV may be counted by an internal Error Counter or may be indicated by the RMFn or TMFn pin. Refer to Section 3.4.6 Error Counter and Section 3.4.7 Receive /Transmit Multiplex Function (RMF / TMF) Indication respectively.

3.4.1.2 Bipolar Violation (BPV) Insertion

The BPV can only be inserted in the transmit path.

A BPV will be inserted on the next available mark in the data stream to be transmitted by writing a '1' to the BPV_INS bit (b6, ERR,...). This bit will be reset once BPV insertion is done.

3.4.2 EXCESSIVE ZEROES (EXZ) DETECTION

EXZ is monitored in both the receive path and the transmit path.

Different line code has different definition of the EXZ. The IDT82P2521 provides two standards of EXZ definition for each kind of line code rule. The standards are ANSI and FCC, as selected by the EXZ_DEF bit (b7, ERR,...). Refer to Table-8 for details.

Table-8 EXZ Definition

Line Code Rule	Definition	
	ANSI (EXZ_DEF = 0)	FCC (EXZ_DEF = 1)
AMI	An EXZ is detected when any string of more than 15 consecutive '0's are received.	An EXZ is detected when any string of more than 15 consecutive '0's are received.
HDB3	An EXZ is detected when any string of more than 3 consecutive '0's are received.	An EXZ is detected when any string of more than 3 consecutive '0's are received.
Note: If the transmit system interface is in Transmit Single Rail NRZ Format mode, the EXZ is detected according to the standard of AMI.		

When EXZ is detected in the receive path, the LEXZ_IS bit (b2, INTS2,...) will be set and an interrupt will be reported by \overline{INT} if not masked by the LEXZ_IM bit (b2, INTM2,...).

When EXZ is detected in the transmit path, the SEXZ_IS bit (b3, INTS2,...) will be set and an interrupt will be reported by \overline{INT} if not masked by the SEXZ_IM bit (b3, INTM2,...).

EXZ may be counted by an internal Error Counter or may be indicated by the RMFn or TMFn pin. Refer to Chapter 3.4.6 Error Counter and Chapter 3.4.7 Receive /Transmit Multiplex Function (RMF / TMF) Indication respectively.

3.4.3 LOSS OF SIGNAL (LOS) DETECTION

The IDT82P2521 detects three kinds of LOS:

- LLOS: Line LOS, detected in the receive path;
- SLOS: System LOS, detected in the transmit system side;
- TLOS: Transmit LOS, detected in the transmit line side.

3.4.3.1 Line LOS (LLOS)

The amplitude and density of the data received from the line side are monitored. When the amplitude of the data is less than Q Vpp for N consecutive pulse intervals, LLOS is declared. When the amplitude of the data is more than P Vpp and the average density of marks is at least 12.5% for M consecutive pulse intervals starting with a mark, LLOS is cleared. Here Q is defined by the ALOS[2:0] bits (b6~4, LOS,...). P is the sum of Q and 250 mVpp. N and M are defined by the LAC bit (b7, LOS,...). Refer to Table-9 for details.

LLOS detection supports G.775 and ETSI 300233/I.431. The criteria are selected by the LAC bit (b7, LOS,...).

When LLOS is detected, the LLOS_S bit (b0, STAT0,...) will be set. A transition from '0' to '1' on the LLOS_S bit (b0, STAT0,...) or any transition (from '0' to '1' or from '1' to '0') on the LLOS_S bit (b0, STAT0,...) will set the LLOS_IS bit (b0, INTS0,...) to '1', as selected by the LOS_IES bit (b1, INTES,...). When the LLOS_IS bit (b0, INTS0,...) is '1', an interrupt will be reported by INT if not masked by the LLOS_IM bit (b0, INTM0,...).

Two pins (LLOS0 and LLOS) are dedicated to LLOS indication. Whether LLOS is detected in channel 0 or not, LLOS0 is high for a CLKE1 clock cycle to indicate the channel 0 position on LLOS. LLOS indicates LLOS status of all 22 channels in a serial format and repeats every 22 cycles. Refer to Figure-22. LLOS0 and LLOS are updated on the rising edge of CLKE1. When the clock output on CLKE1 is disabled, LLOS0 and LLOS will be held in High-Z state. The output on CLKE1 is controlled by the CLKE1_EN bit (b3, CLKG) and the CLKE1 bit (b2, CLKG). Refer to section 8.9 on page 129 for CLKE1 timing characteristics.

LLOS may be counted by an internal Error Counter or may be indicated by the RMFn pin. Refer to Section 3.4.6 Error Counter and Section 3.4.7.1 RMFn Indication respectively.

During LLOS, in Receive Single Rail NRZ Format mode, Receive Dual Rail NRZ Format mode and Receive Dual Rail RZ Format mode, RDn and RDPn/RDNn output low level. In Receive Dual Rail Sliced mode RDPn/RDNn still output sliced data. RCLKn (if available) outputs high level or XCLK¹, as selected by the RCKH bit (b7, RCF0,...).

During LLOS, if any of AIS, pattern generation in the receive path or Digital Loopback is enabled, RDn, RDPn/RDNn and RCLKn output corresponding data and clock, and the setting of the RCKH bit (b7, RCF0,...) is ignored. Refer to the corresponding chapters for details.

1. XCLK is derived from MCLK. It is 2.048 MHz .

Table-9 LLOS Criteria

Operation Mode	LAC	Criteria	LLOS Declaring	LLOS Clearing
E1	0	G.775	below Q Vpp, N = 32 bits	above P Vpp, 12.5% mark density with less than 16 consecutive zeros, M = 32 bits
	1	ETSI 300233/ I.431	below Q Vpp, N = 2048 bits	above P Vpp, 12.5% mark density with less than 16 consecutive zeros, M = 32 bits

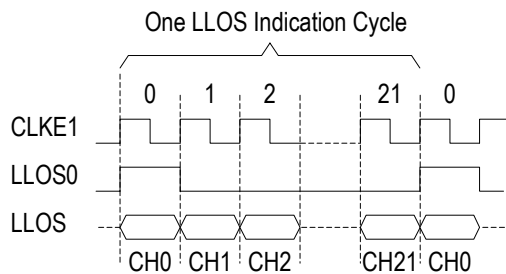

Figure-22 LLOS Indication on Pins

3.4.3.2 System LOS (SLOS)

SLOS can only be detected when the transmit system interface is in Dual Rail NRZ Format mode or in Dual Rail RZ Format mode.

The amplitude and density of the data input from the transmit system side are monitored. When the input '0's are equal to or more than N consecutive pulse intervals, SLOS is declared. When the average density of marks is at least 12.5% for M consecutive pulse intervals starting with a mark, SLOS is cleared. Here N and M are defined by the LAC bit (b7, LOS,...). Refer to Table-10 for details.

SLOS detection supports G.775 and ETSI 300233/I.431. The criteria are selected by the LAC bit (b7, LOS,...).

When SLOS is detected, the SLOS_S bit (b1, STAT0,...) will be set. A transition from '0' to '1' on the SLOS_S bit (b1, STAT0,...) or any transition (from '0' to '1' or from '1' to '0') on the SLOS_S bit (b1, STAT0,...) will set the SLOS_IS bit (b1, INTS0,...) to '1', as selected by the LOS_IES bit (b1, INTES,...). When the SLOS_IS bit (b1, INTS0,...) is '1', an interrupt will be reported by $\overline{\text{INT}}$ if not masked by the SLOS_IM bit (b1, INTM0,...).

SLOS may be counted by an internal Error Counter or may be indicated by the TMFn pin. Refer to Section 3.4.6 Error Counter and Section 3.4.7.2 TMFn Indication respectively.

Table-10 SLOS Criteria

Operation Mode	LAC	Criteria	SLOS Declaring ¹	SLOS Clearing ¹
E1	0	G.775	no pulse detected for N consecutive pulse intervals, N = 32 bits	12.5% mark density with less than 16 consecutive zeros for M consecutive pulse intervals, M = 32 bits
	1	ETSI 300233/ I.431	no pulse detected for N consecutive pulse intervals, N = 2048 bits	12.5% mark density with less than 16 consecutive zeros for M consecutive pulse intervals, M = 32 bits

Note:

1. System input ports are schmitt-trigger inputs)

3.4.3.3 Transmit LOS (TLOS)

The amplitude and density of the data output on the transmit line side are monitored. When the amplitude of the data is less than a certain voltage for a certain period, TLOS is declared. The voltage is defined by the TALOS[1:0] bits (b3~2, LOS,...). The period is defined by the TDLOS[1:0] bits (b1~0, LOS,...). When a valid pulse is detected, i.e., the amplitude is above the setting in the TALOS[1:0] bits (b3~2, LOS,...), TLOS is cleared.

When TLOS is detected, the TLOS_S bit (b2, STAT0,...) will be set. A transition from '0' to '1' on the TLOS_S bit (b2, STAT0,...) or any transition (from '0' to '1' or from '1' to '0') on the TLOS_S bit (b2, STAT0,...) will set the TLOS_IS bit (b2, INTS0,...) to '1', as selected by the TLOS_IES bit (b2, INTES,...). When the TLOS_IS bit (b2, INTS0,...) is '1', an interrupt will be reported by \overline{INT} if not masked by the TLOS_IM bit (b2, INTM0,...).

TLOS may be counted by an internal Error Counter or may be indicated by the TMFn pin. Refer to Section 3.4.6 Error Counter and Section 3.4.7.2 TMFn Indication respectively.

TLOS can be used to monitor the LOS in the transmit line side between two channels. The connection between the two channels is shown in Figure-23. The two channels can be of the same device or different devices on the premises that the transmit line interfaces are in the same mode and at least the output of one channel is in High-Z state. Table-11 lists each results in this case. In the left two columns, the OE bit (b6, TCF0,...) of the two channels controls the output status in the

transmit line side to ensure that at least one channel is in High-Z state. The middle two columns list the internal operation status. In the right two columns, the TLOS_S bit (b2, STAT0,...) of the two channels indicates the TLOS status in the transmit line side.

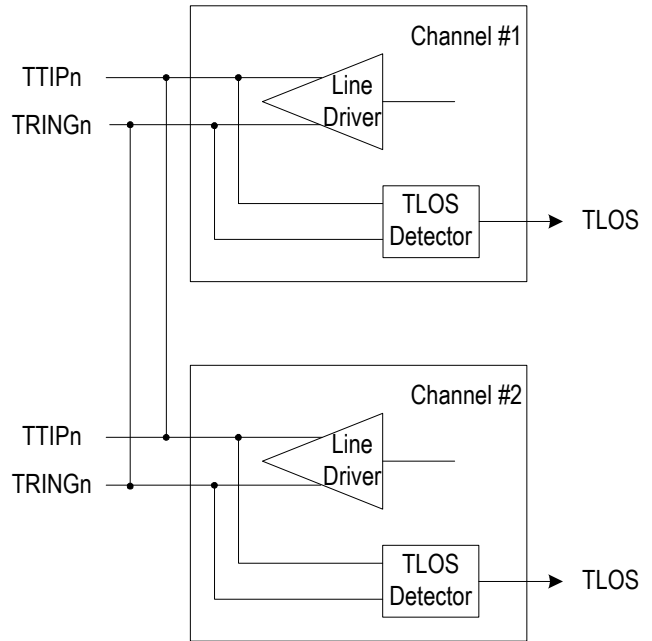

Figure-23 TLOS Detection Between Two Channels

Table-11 TLOS Detection Between Two Channels

Output Status ~ Controlled By the OE Bit		Internal Operation Status		TLOS Status ~ Indicated By the TLOS_S Bit	
Channel #1	Channel #2	Channel #1	Channel #2	Channel #1	Channel #2
Normal ~ 1	High-Z ~ 0	Normal	(don't-care)	No TLOS ~ 0	No TLOS ~ 0
Normal ~ 1	High-Z ~ 0	Failure	Normal	TLOS Detected ~ 1 *	TLOS Detected ~ 1
High-Z ~ 0	Normal ~ 1	(don't-care)	Normal	No TLOS ~ 0	No TLOS ~ 0
High-Z ~ 0	Normal ~ 1	Normal	Failure	TLOS Detected ~ 1	TLOS Detected ~ 1 *
High-Z ~ 0	High-Z ~ 0	(don't-care)	(don't-care)	TLOS Detected ~ 1	TLOS Detected ~ 1

Note:

* The TLOS_S bit (b2, STAT0,...) may not be set if there is any catastrophic failure in the channel.

3.4.4 ALARM INDICATION SIGNAL (AIS) DETECTION AND GENERATION

3.4.4.1 Alarm Indication Signal (AIS) Detection

AIS is monitored in both the receive path and the transmit path.

When the mark density in the received data or in the data input from the transmit system side meets certain criteria, AIS is declared or cleared. In E1 mode, the criteria are in compliance with ITU G.775 or ETSI 300233, as selected by the LAC bit (b7, LOS,...). Refer to Table-12 for details.

Table-12 AIS Criteria

	ITU G.775 for E1 (LAC = 0)	ETSI 300233 for E1 (LAC = 1)
AIS Declaring	Less than 3 zeros are received in each of two consecutive 512-bit data streams.	Less than 3 zeros are received in a 512-bit data stream.
AIS Clearing	3 or more zeros are received in each of two consecutive 512-bit data streams.	3 or more zeros are received in a 512-bit data stream.

When AIS is detected in the receive path, the LAIS_S bit (b6, STAT1,...) will be set. A transition from '0' to '1' on the LAIS_S bit (b6, STAT1,...) or any transition (from '0' to '1' or from '1' to '0') on the LAIS_S bit (b6, STAT1,...) will set the LAIS_IS bit (b6, INTS1,...) to '1', as selected by the AIS_IES bit (b6, INTES,...). When the LAIS_IS bit (b6, INTS1,...) is '1', an interrupt will be reported by $\overline{\text{INT}}$ if not masked by the LAIS_IM bit (b6, INTM1,...).

When AIS is detected in the transmit path, the SAIS_S bit (b7, STAT1,...) will be set. A transition from '0' to '1' on the SAIS_S bit (b7, STAT1,...) or any transition (from '0' to '1' or from '1' to '0') on the SAIS_S bit (b7, STAT1,...) will set the SAIS_IS bit (b7, INTS1,...) to '1', as selected by the AIS_IES bit (b6, INTES,...). When the SAIS_IS bit (b7, INTS1,...) is '1', an interrupt will be reported by $\overline{\text{INT}}$ if not masked by the SAIS_IM bit (b7, INTM1,...).

AIS may be counted by an internal Error Counter or may be indicated by the RMFn or TMFn pin. Refer to Section 3.4.6 Error Counter and Section 3.4.7 Receive /Transmit Multiplex Function (RMF / TMF) Indication respectively.

3.4.4.2 (Alarm Indication Signal) AIS Generation

AIS can be generated automatically in the receive path and the transmit path.

In the receive path, when the AS AIS_LLOS bit (b2, AISG,...) is set, AIS will be generated automatically once LLOS is detected. When the AS AIS_SLOS bit (b3, AISG,...) is set, AIS will be generated automatically once SLOS is detected. When AIS is generated, RDn or RDPn/RDNn output all '1's. RCLKn (if available) outputs XCLK.

In the transmit path, when the ALAIS_LLOS bit (b0, AISG,...) is set, AIS will be generated automatically once LLOS is detected. When the ALAIS_SLOS bit (b1, AISG,...) is set, AIS will be generated automatically once SLOS is detected. When AIS is generated, TTIPn/TRINGn output all '1's.

AIS generation uses XCLK¹ as reference clock.

If pattern (including PRBS, ARB and IB) is generated in the same direction, the priority of pattern generation is higher. The generated pattern will overwrite automatic AIS. Refer to Section 3.4.5.1 Pattern Generation for the output data and clock.

1. XCLK is derived from MCLK. It is 2.048 MHz.

3.4.5 PRBS, QRSS, ARB AND IB PATTERN GENERATION AND DETECTION

The pattern includes: Pseudo Random Bit Sequence (PRBS), Quasi-Random Signal Source (QRSS), Arbitrary Pattern (ARB) and Inband Loopback (IB).

3.4.5.1 Pattern Generation

The pattern can be generated in the receive path or the transmit path, as selected by the PG_POS bit (b3, PG,...).

The pattern to be generated is selected by the PG_EN[1:0] bits (b5~4, PG,...).

If PRBS is selected, three kinds of PRBS patterns with maximum zero restriction according to ITU-T O.151 and AT&T TR62411 are provided. They are: ($2^{20} - 1$) QRSS per O.150-4.5, ($2^{15} - 1$) PRBS per O.152 and ($2^{11} - 1$) PRBS per O.150, as selected by the PRBG_SEL[1:0] bits (b1~0, PG,...).

If ARB is selected, the content is programmed in the ARB[23:0] bits (b7~0, ARBH~ARBM~ARBL,...).

If IB is selected, the IB generation is in compliance with ANSI T1.403. The length of the IB code can be 3 to 8 bits, as determined by the IBGL[1:0] bits (b5~4, IBL,...). The content is programmed in the IBG[7:0] bits (b7~0, IBG,...).

The selected pattern is transmitted repeatedly until the PG_EN[1:0] bits (b5~4, PG,...) is set to '00'.

When pattern is generated in the receive path, the reference clock is XCLK or the recovered clock from the received signal, as selected by the PG_CK bit (b6, PG,...). The selected reference clock is also output on RCLKn (if available).

When pattern is generated in the transmit path, the reference clock is XCLK¹ or the transmit clock, as selected by the PG_CK bit (b6, PG,...). The transmit clock refers to the clock input on TCLKn (in Transmit Single Rail NRZ Format mode and in Transmit Dual Rail NRZ Format mode) or the clock recovered from the data input on TDPn and TDNn (in Transmit Dual Rail RZ Format mode).

In summary, do the followings step by step to generate pattern:

- Select the generation direction by the PG_POS bit (b3, PG,...);
- Select the reference clock by the PG_CK bit (b6, PG,...);
- Select the PRBS pattern by the PRBG_SEL[1:0] bits (b1~0, PG,...) when PRBS is to be generated; program the ARB pattern in the ARB[23:0] bits (b7~0, ARBH~ARBM~ARBL,...) when ARB is to be generated; or set the length and the content of the IB code in the IBGL[1:0] bits (b5~4, IBL,...) and in the IBG[7:0] bits (b7~0, IBG,...) respectively when IB is to be generated;
- Set the PG_EN[1:0] bits (b5~4, PG,...) to generate the pattern.

1. XCLK is derived from MCLK. It is 2.048 MHz.

If PRBS or ARB is selected to be generated, the following two steps can be optionally implemented after the pattern is generated:

- Insert a single bit error by writing '1' to the ERR_INS bit (b5, ERR,...);
- Invert the generated pattern by setting the PAG_INV bit (b2, PG,...).

If pattern is generated in the receive path, the generated pattern should be encoded by using AMI HDB3 in Receive Dual Rail NRZ Format mode, Receive Dual Rail RZ Format mode and Receive Dual Rail Sliced mode. The encoding rule is selected by the R_CODE bit (b2, RCF1,...).

If pattern is generated in the transmit path, the generated pattern should be encoded by using AMI HDB3. The encoding rule is selected by the T_CODE bit (b2, TCF1,...).

The pattern generation is shown in Figure-24 and Figure-25.

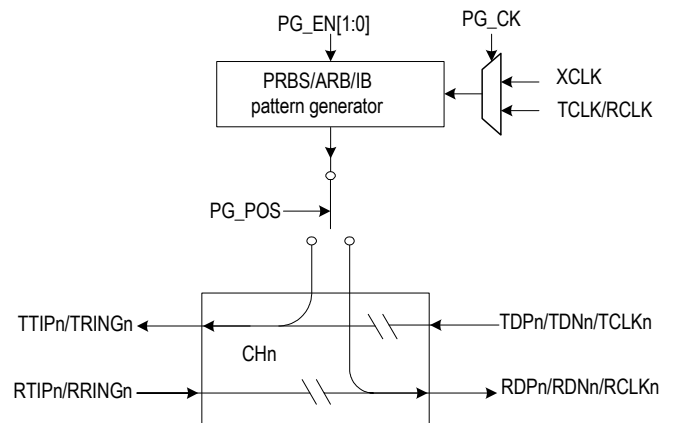

Figure-24 Pattern Generation (1)

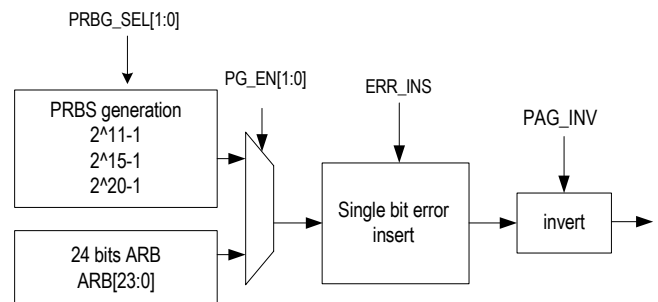

Figure-25 Pattern Generation (2)

The priority of pattern generation is higher than that of AIS generation. If they are generated in the same direction, the generated pattern will overwrite the generated AIS.

3.4.5.2 Pattern Detection

Data received from the line side or data input from the transmit system side may be extracted for pattern detection. The direction of data extraction is determined by the PD_POS bit (b3, PD,...). One of PRBS or ARB pattern is selected for detection and IB detection is always active.

If data is extracted from the receive path, before pattern detection the data should be decoded by using AMI / HDB3. The decoding rule is selected by the R_CODE bit (b2, RCF1,...).

If data is extracted from the transmit path, before pattern detection the data should be decoded by using AMI HDB3 in Transmit Dual Rail NRZ Format mode and Transmit Dual Rail RZ Format mode. The decoding rule is selected by the T_CODE bit (b2, TCF1,...).

Pseudo Random Bit Sequence (PRBS) /Arbitrary Pattern (ARB) Detection

The extracted data can be optionally inverted by the PAD_INV bit (b2, PD,...) before PRBS/ARB detection.

The extracted data is used to compare with the desired pattern. The desired pattern is re-generated from the extracted data if the desired pattern is $(2^{20} - 1)$ QRSS per O.150-4.5, $(2^{15} - 1)$ PRBS per O.152 or $(2^{11} - 1)$ PRBS per O.150; or the desired pattern is programmed in the ARB[23:0] bits (b7~0, ARBH~ARBM~ARBL,...) if the desired pattern is ARB. The desired pattern is selected by the PAD_SEL[1:0] bits (b1~0, PD,...).

In summary, do the followings step by step to detect PRBS/ARB:

- Select the detection direction by the PD_POS bit (b3, PD,...);
- Set the ARB[23:0] bits (b7~0, ARBH~ARBM~ARBL,...) if the ARB pattern is desired - this step is omitted if the PRBS pattern is desired;
- Select the desired PRBS/ARB pattern by the PAD_SEL[1:0] bits (b1~0, PD,...).

The priority of decoding, data inversion, pattern re-generation, bit programming and pattern comparison is shown in Figure-26.

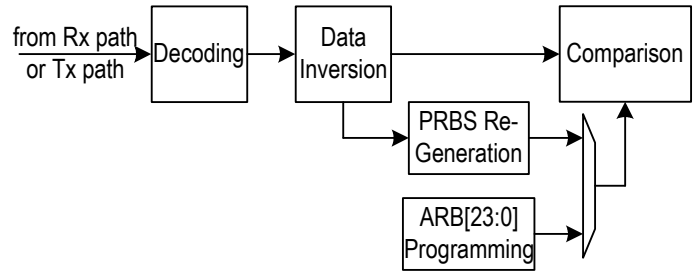

Figure-26 PRBS / ARB Detection

During comparison, if the extracted data coincides with the re-generated PRBS pattern or the programmed ARB pattern for more than 64-bit hopping window, the pattern is synchronized and the PA_S bit (b5, STAT1,...) will be set.

In synchronization state, if more than 6 PRBS/ARB errors are detected in a 64-bit hopping window, the pattern is out of synchronization and the PA_S bit (b5, STAT1,...) will be cleared.

In synchronization state, each mismatched bit will generate a PRBS/ARB error. When a PRBS/ARB error is detected during the synchronization, the ERR_IS bit (b1, INTS2,...) will be set and an interrupt will be reported by $\overline{\text{INT}}$ if not masked by the ERR_IM bit (b1, INTM2,...). The PRBS/ARB error may be counted by an internal Error Counter. Refer to Section 3.4.6 Error Counter.

A transition from '0' to '1' on the PA_S bit (b5, STAT1,...) or any transition (from '0' to '1' or from '1' to '0') on the PA_S bit (b5, STAT1,...) will set the PA_IS bit (b5, INTS1,...) to '1', as selected by the PA_IES bit (b5, INTES,...). When the PA_IS bit (b5, INTS1,...) is '1', an interrupt will be reported by INT if not masked by the PA_IM bit (b5, INTM1,...).

The PRBS/ARB synchronization status may be indicated by the RMFn or TMFn pin. Refer to Section 3.4.7 Receive /Transmit Multiplex Function (RMF / TMF) Indication.

Inband Loopback (IB) Detection

The IB detection is in compliance with ANSI T1.403.

The extracted data is used to compare with the target IB code. The length of the target activate/deactivate IB code can be 3 to 8 bits, as determined by the IBAL[1:0]/IBDL[1:0] bits (b3~2/b1~0, IBL,...). The content of the target activate/deactivate IB code is programmed in the IBA[7:0]/IBD[7:0] bits (b7~0, IBDA/IBDD,...). Refer to Figure-27.

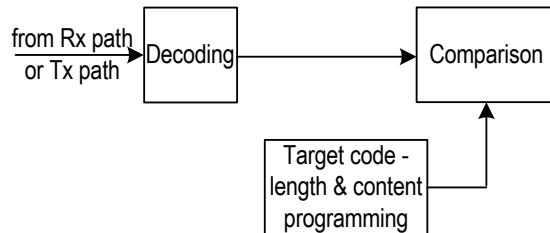

Figure-27 IB Detection

During comparison, if the extracted data coincides with the target activate/deactivate IB code with no more than 10^{-2} bit error rate for a certain period, the IB code is detected. The period depends on the setting of the AUTOLP bit (b3, LOOP,...).

If the AUTOLP bit (b3, LOOP,...) is '0', Automatic Digital/Remote Loopback is disabled. In this case, when the activate IB code is detected for more than 40 ms, the IBA_S bit (b1, STAT1,...) will be set to indicate the activate IB code detection; when the deactivate IB code is detected for more than 30 ms, the IBD_S bit (b0, STAT1,...) will be set to indicate the deactivate IB code detection.

If the AUTOLP bit (b3, LOOP,...) is '1', Automatic Digital/Remote Loopback is enabled. In this case, when the activate IB code is detected for more than 5.1 seconds, the IBA_S bit (b1, STAT1,...) will be set to indicate the activate IB code detection. The detection of the activate IB code in the receive path will activate Remote Loopback or the detection of the activate IB code in the transmit path will activate Digital Loopback (refer to Section 3.4.8.2 Remote Loopback & Section 3.4.8.3 Digital Loopback). When the deactivate IB code is detected for more than 5.1 seconds, the IBD_S bit (b0, STAT1,...) will be set to indicate the deactivate IB code detection. The detection of the deactivate IB code in the receive path will deactivate Remote Loopback or the detection of the deactivate IB code in the transmit path will deactivate Digital Loopback (refer to Section 3.4.8.2 Remote Loopback & Section 3.4.8.3 Digital Loopback).

A transition from '0' to '1' on the IBA_S/IBD_S bit (b1/b0, STAT1,...) or any transition (from '0' to '1' or from '1' to '0') on the IBA_S/IBD_S bit (b1/b0, STAT1,...) will set the IBA_IS/IBD_IS bit (b1/b0, INTS1,...) to '1'

respectively, as selected by the IB_IES bit (b0, INTES,...). When the IBA_IS/IBD_IS bit (b1/b0, INTS1,...) is '1', an interrupt will be reported on \overline{INT} if not masked by the IBA_IM/IBD_IM bit (b1/b0, INTM1,...).

3.4.6 ERROR COUNTER

An internal 16-bit Error Counter is used to count one of the following errors:

- LBPV: BPV/CV detected in the receive path (line side);
- LEXZ: EXZ detected in the receive path (line side);
- LBPV + LEXZ: BPV/CV and EXZ detected in the receive path (line side);
- SBPV: BPV/CV detected in the transmit path (system side) (disabled in Transmit Single Rail NRZ Format mode);
- SEXZ: EXZ detected in the transmit path (system side);
- SBPV + SEXZ: BPV/CV and EXZ detected in the transmit path (system side) (disabled in Transmit Single Rail NRZ Format mode);
- PRBS/ARB error.

The CNT_SEL[2:0] bits (b4~2, ERR,...) select one of the above errors to be counted.

The Error Counter is buffered. It is updated automatically or manually, as determined by the CNT_MD bit (b1, ERR,...).

The Error Counter is accessed by reading the ERRCH and ERRCL registers.

3.4.6.1 Automatic Error Counter Updating

When the CNT_MD bit (b1, ERR,...) is '1', the Error Counter is updated every one second automatically.

The one-second timer uses MCLK as clock reference. The expiration of each one second will set the TMOV_IS bit (b0, INTTM) and induce an interrupt reported by \overline{INT} if not masked by the TMOV_IM bit (b0, GCF).

When each one second expires, the Error Counter transfers the accumulated error numbers to the ERRCH and ERRCL registers and the Error Counter will be cleared to start a new round counting. The ERRCH and ERRCL registers should be read in the next second, otherwise they will be overwritten.

When the ERRCH and ERRCL registers are all '1's and there is still error to be accumulated, the registers will be overflowed. The overflow is indicated by the CNTOV_IS bit (b0, INTS2,...) and will induce an interrupt reported by \overline{INT} if not masked by the CNTOV_IM (b0, INTM2,...).

The process of automatic Error Counter updating is illustrated in Figure-28.

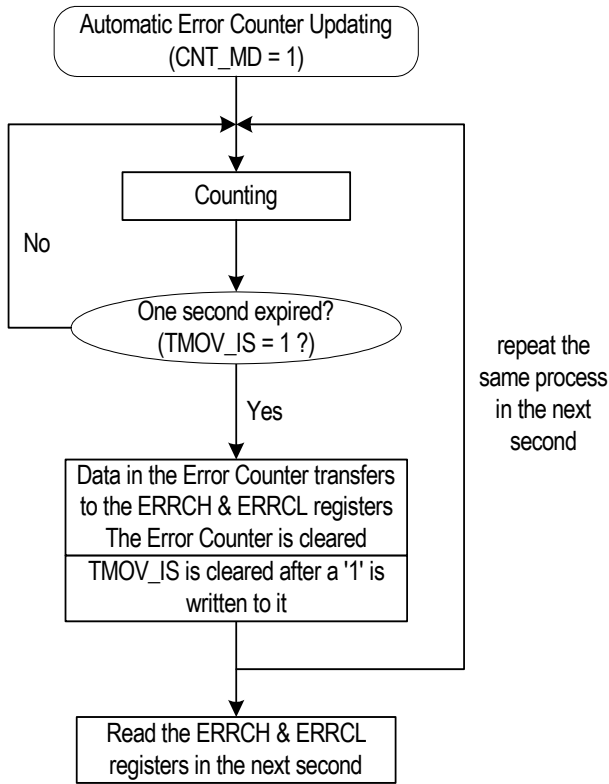

Figure-28 Automatic Error Counter Updating

3.4.6.2 Manual Error Counter Updating

When the CNT_MD bit (b1, ERR,...) is '0', the Error Counter is updated manually.

When there is a transition from '0' to '1' on the CNT_STOP bit (b0, ERR,...), the Error Counter transfers the accumulated error numbers to the ERRCH and ERRCL registers and the Error Counter will be cleared to start a new round counting. The ERRCH and ERRCL registers should be read in the next round of error counting, otherwise they will be overwritten.

When the ERRCH and ERRCL registers are all '1's and there is still error to be accumulated, the registers will be overflowed. The overflow is indicated by the CNTOV_IS bit (b0, INTS2,...) and will induce an interrupt reported by INT if not masked by the CNTOV_IM (b0, INTM2,...).

The process of manual Error Counter updating is illustrated in Figure-29.

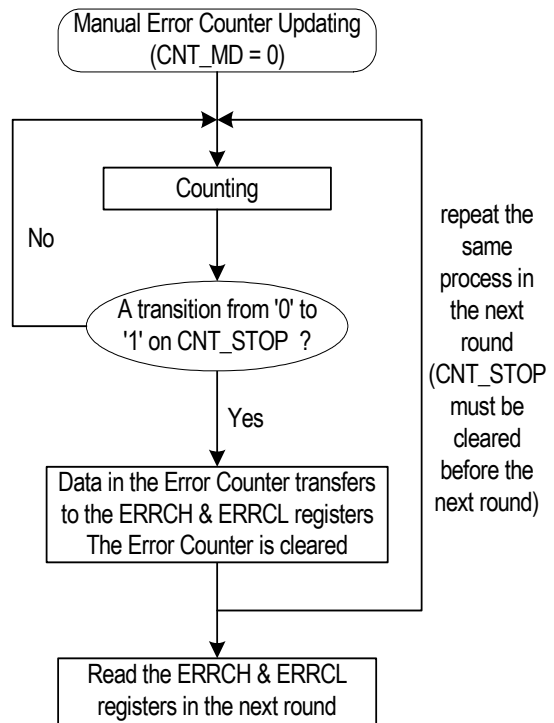

Figure-29 Manual Error Counter Updating

3.4.7 RECEIVE /TRANSMIT MULTIPLEX FUNCTION (RMF / TMF) INDICATION

3.4.7.1 RMFn Indication

In Receive Single Rail NRZ Format mode, the RDn/RMFn pin is used as RMFn. In Receive Dual Rail Sliced mode, the RCLKn/RMFn pin is used as RMFn. Refer to Table-2 Multiplex Pin Used in Receive System Interface for details.

RMFn can indicate the status of PRBS/ARB, LAIS, LEXZ, LBPV, LEXZ + LBPV, LLOS, output recovered clock (RCLK) or XOR output of positive and negative sliced data, as selected by the RMF_DEF[2:0] bits (b7~5, RCF1,...). Refer to Table-13 for details.

Table-13 RMFn Indication

RMF_DEF[2:0]	Indication On RMF	Details
000	PRBS/ARB	RMFn is high if PRBS/ARB is detected in synchronization in the receive path. During the synchronization, RMFn goes low for a E1 clock cycle if a PRBS/ARB error is detected. RMFn is low if PRBS/ARB is out of synchronization. Refer to Section 3.4.5 PRBS, QRSS, ARB and IB Pattern Generation and Detection.
001	Line Alarm Indication Signal (LAIS)	RMFn is high if AIS is detected in the receive path and low if it is cleared. This indication corresponds to the LAIS_S bit (b6, STAT1,...). Refer to Section 3.4.4 Alarm Indication Signal (AIS) Detection and Generation.
010	XOR result of positive and negative sliced data	RMFn outputs XOR data of positive and negative sliced data.
011	recovered clock (RCLK)	RMFn outputs the recovered clock as RCLKn. All the description about RCLKn is applicable for RMFn.
100	Line Excessive Zeroes (LEXZ)	RMFn goes high for a E1 clock cycle if an EXZ is detected in the receive path, otherwise it is low. Refer to Section 3.4.2 Excessive Zeroes (EXZ) Detection.
101	Line Bipolar Violation (LBPV)	RMFn goes high for a E1 clock cycle if a BPV/CV is detected in the receive path, otherwise it is low. Refer to Section 3.4.1 Bipolar Violation (BPV) / Code Violation (CV) Detection and BPV Insertion.
110	LEXZ + LBPV	RMFn goes high for a E1 clock cycle if an EXZ or a BPV/CV is detected in the receive path, otherwise it is low.
111	Line Loss of Signal (LLOS)	RMFn is high if LOS is detected in the receive path and low if it is cleared. This indication corresponds to the LLOS_S bit (b0, STAT0,...). Refer to Section 3.4.3.1 Line LOS (LLOS).

3.4.7.2 TMFn Indication

In Transmit Single Rail NRZ Format mode and Transmit Dual Rail RZ Format mode, the TDNn/TMFn pin is used as TMFn. Refer to Table-3 Multiplex Pin Used in Transmit System Interface for details.

TMFn can indicate the status of PRBS/ARB, SAIS, TOC, TLOS, SEXZ, SBPV, SEXZ + SBPV or SLOS, as selected by the TMF_DEF[2:0] bits (b7~5, TCF1,...). However, the indication of SBPV, SEXZ + SBPV and SLOS is disabled automatically in Transmit Single Rail NRZ Format mode. Refer to Table-14 for details.

Table-14 TMFn Indication

TMF_DEF[2:0]	Indication On TMF	Details
000	PRBS/ARB	TMFn is high if PRBS/ARB is detected in synchronization in the transmit path. During the synchronization, TMFn goes low for a E1 clock cycle if a PRBS/ARB error is detected. TMFn is low if PRBS/ARB is out of synchronization.
001	System Alarm Indication Signal (SAIS)	TMFn is high if AIS is detected in the transmit path and low if it is cleared. This indication corresponds to the SAIS_S bit (b7, STAT1,...). Refer to Section 3.4.4 Alarm Indication Signal (AIS) Detection and Generation.
010	Transmit Over Current (TOC)	TMFn is high if transmit over current is detected and low if it is cleared. This indication corresponds to the TOC_S bit (b4, STAT0,...). Refer to Section 3.2.5.1 Transmit Over Current Protection.
011	Transmit Loss of Signal (TLOS)	TMFn is high if LOS is detected in the transmit line side and low if it is cleared. This indication corresponds to the TLOS_S bit (b2, STAT0,...). Refer to Section 3.4.3.3 Transmit LOS (TLOS).
100	System Excessive Zeroes (SEXZ)	TMFn goes high for a E1 clock cycle if an EXZ is detected in the transmit path, otherwise it is low. Refer to Section 3.4.2 Excessive Zeroes (EXZ) Detection
101	System Bipolar Violation (SBPV) *	TMFn goes high for a E1 clock cycle if a BPV/CV is detected in the transmit path, otherwise it is low. Refer to Section 3.4.1 Bipolar Violation (BPV) / Code Violation (CV) Detection and BPV Insertion.
110	System Excessive Zeroes (SEXZ) + System Bipolar Violation (SBPV) *	TMFn goes high for a E1 clock cycle if an EXZ or a BPV/CV is detected in the transmit path, otherwise it is low.
111	System Loss of Signal (SLOS) *	TMFn is high if LOS is detected in the transmit system side and low if it is cleared. This indication corresponds to the SLOS_S bit (b1, STAT0,...). Refer to Section 3.4.3.2 System LOS (SLOS).
Note: * In Transmit Single Rail NRZ Format mode, the corresponding indication is disabled and the corresponding setting is reserved.		

3.4.8 LOOPBACK

There are four kinds of loopback:

- Analog Loopback
- Remote Loopback
- Digital Loopback
- Dual Loopback

Refer to Figure-1 for loopback location.

3.4.8.1 Analog Loopback

Analog Loopback is enabled by the ALP bit (b0, LOOP,...). The data stream to be transmitted on the TTIPn/TRINGn pins is internally looped to the RTIPn/RRINGn pins.

In Analog Loopback mode, the data stream to be transmitted is still output to the line side, while the data stream received from the line side is covered by the Analog Loopback data.

Anytime when Analog Loopback is set, the other loopbacks (i.e., Digital Loopback and Remote Loopback) are disabled.

In Analog Loopback, the priority of the diagnostic facilities in the receive path is: pattern generation > looped data. AIS generation is disabled in both the receive path and the transmit path. Refer to Figure-30.

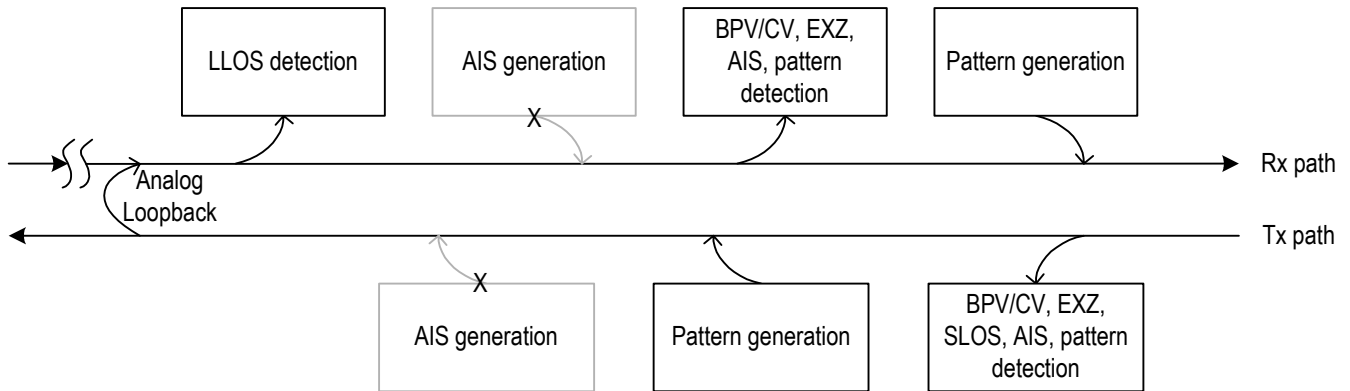

Figure-30 Priority Of Diagnostic Facilities During Analog Loopback

3.4.8.2 Remote Loopback

Remote Loopback can be configured manually or automatically. Either manual Remote Loopback configuration or automatic Remote Loopback configuration will enable Remote Loopback.

Manual Remote Loopback is enabled by the RLP bit (b1, LOOP,...).

Automatic Remote Loopback is enabled when the pattern detection is assigned in the receive path (i.e., the PD_POS bit (b3, PD,...) is '0') and the AUTOLP bit (b3, LOOP,...) is '1'. The corresponding channel will enter Remote Loopback when the activate IB code is detected in the receive path for more than 5.1 sec.; and will return from Remote Loopback when the deactivate IB code is detected in the receive path for more than 5.1 sec. Refer to section Inband Loopback (IB) Detection on page 49 for details. When automatic Remote Loopback is active, setting the AUTOLP bit (b3, LOOP,...) back to '0' will also stop automatic

Remote Loopback. The setting of the PD_POS bit (b3, PD,...) should not be changed during automatic Remote Loopback. The AUTOLP_S bit (b7, STAT0,...) indicates the automatic Remote Loopback status.

In Remote Loopback mode, the data stream output from the RJA (if enabled) is internally looped to the Waveform Shaper. The data stream received from the line side is still output to the system side, while the data stream input from the system side is covered by the Remote Loopback data and the status on TCLKn does not affect the Remote Loopback. However, the BPV/CV, EXZ, SLOS, AIS and pattern detection in the transmit path still monitors the data stream input from the system side.

In Remote Loopback mode, the priority of the diagnostic facilities in the receive path is: pattern generation > AIS generation; the priority of the diagnostic facilities in the transmit path is: pattern generation > looped data. AIS generation is disabled in the transmit path. Refer to Figure-31.

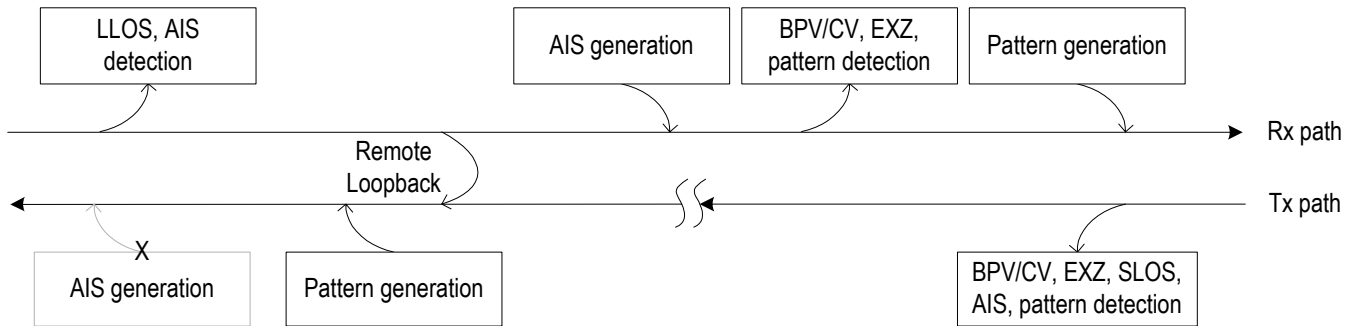

Figure-31 Priority Of Diagnostic Facilities During Manual Remote Loopback

3.4.8.3 Digital Loopback

The Digital Loopback can be configured manually or automatically. Either manual Digital Loopback configuration or automatic Digital Loopback configuration will enable Digital Loopback.

Manual Digital Loopback is enabled by the DLP bit (b2, LOOP,...).

Automatic Digital Loopback is enabled when the pattern detection is assigned in the transmit path (i.e., the PD_POS bit (b3, PD,...) is '1') and the AUTOLP bit (b3, LOOP,...) is '1'. The corresponding channel will enter Digital Loopback when the activate IB code is detected in the transmit path for more than 5.1 sec.; and will return from Digital Loopback when the deactivate IB code is detected in the transmit path for more than 5.1 sec. Refer to section Inband Loopback (IB) Detection on page 49 for details. When automatic Digital Loopback is active, setting the AUTOLP bit (b3, LOOP,...) back to '0' will also stop automatic Digital

Loopback. The setting of the PD_POS bit (b3, PD,...) should not be changed during automatic Digital Loopback. The AUTOLP_S bit (b7, STAT0,...) indicates the automatic Digital Loopback status.

In Digital Loopback mode, the data stream output from the TJA (if enabled) is internally looped to the Decoder (if enabled). The data stream to be transmitted is still output to the line side, while the data stream received from the line side is covered by the Digital Loopback data. However, LLOS and AIS detection in the receive path still monitors the data stream received from the line side.

In Digital Loopback mode, the priority of the diagnostic facilities in the receive path is: pattern generation > looped data; the priority of the diagnostic facilities in the transmit path is: pattern generation > looped data > AIS generation. AIS generation is disabled in the receive path.

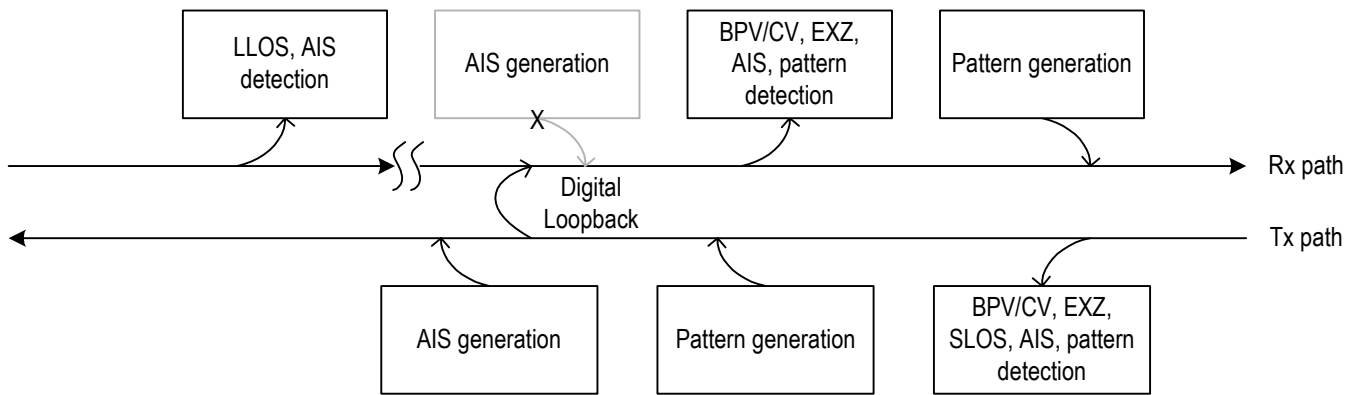

Figure-32 Priority Of Diagnostic Facilities During Digital Loopback

3.4.8.4 Dual Loopback

Dual Loopback refers to the simultaneous implementation of Remote Loopback and Digital Loopback. Two kinds of combinations are supported:

- Manual Remote Loopback + Manual Digital Loopback;
- Manual Remote Loopback + Automatic Digital Loopback.

Note that when Digital Loopback is active, automatic Remote Loopback is unavailable as the pattern detection is within the digital loop.

In Dual Loopback mode, the data stream received from the line side outputs from the RJA (if enabled), loops to the Waveform Shaper internally and does not output to the system side. The data stream to be transmitted from the system side outputs from the TJA (if enabled), loops to the Decoder (if enabled) internally and does not output to the line side. LLOS, AIS detection in the receive path monitors the data stream received from the line side. The BPV/CV, EXZ and pattern detection in the receive path monitors the digital looped data. The BPV/CV, EXZ, SLOS, AIS and pattern detection in the transmit path monitors the data stream input from the system side.

Manual Remote Loopback + Manual Digital Loopback

This combination of Dual Loopback is enabled when both manual Remote Loopback and manual Digital Loopback are enabled. Manual Remote Loopback is enabled by the RLP bit (b1, LOOP,...). Manual Digital Loopback is enabled by the DLP bit (b2, LOOP,...).

In this condition, the priority of the diagnostic facilities in the receive path is: pattern generation > digital looped data; the priority of the diagnostic facilities in the transmit path is: remote looped data > pattern generation. AIS generation is disabled in both the receive path and the transmit path.

Refer to Figure-33.

Manual Remote Loopback + Automatic Digital Loopback

This combination of Dual Loopback is enabled when both manual Remote Loopback and automatic Digital Loopback are enabled. Manual Remote Loopback is enabled by the RLP bit (b1, LOOP,...). Automatic Digital Loopback is enabled when the pattern detection is assigned in the transmit path (i.e., the PD_POS bit (b3, PD,...) is '1') and the AUTOLP bit (b3, LOOP,...) is '1'. The corresponding channel will enter Digital Loopback when the activate IB code is detected in the transmit path for more than 5.1 sec.; and will return from Digital Loopback when the deactivate IB code is detected in the transmit path for more than 5.1 sec. Refer to section Inband Loopback (IB) Detection on page 49 for details. When automatic Digital Loopback is active, setting the AUTOLP bit (b3, LOOP,...) back to '0' will also stop automatic Digital Loopback. The setting of the PD_POS bit (b3, PD,...) should not be changed during automatic Digital Loopback. The AUTOLP_S bit (b7, STAT0,...) indicates the automatic Digital Loopback status.

In this condition, the priority of the diagnostic facilities in the receive path is: pattern generation > digital looped data. AIS generation in both the receive path and the transmit path, the pattern generation in the transmit path are disabled.

Refer to Figure-34.

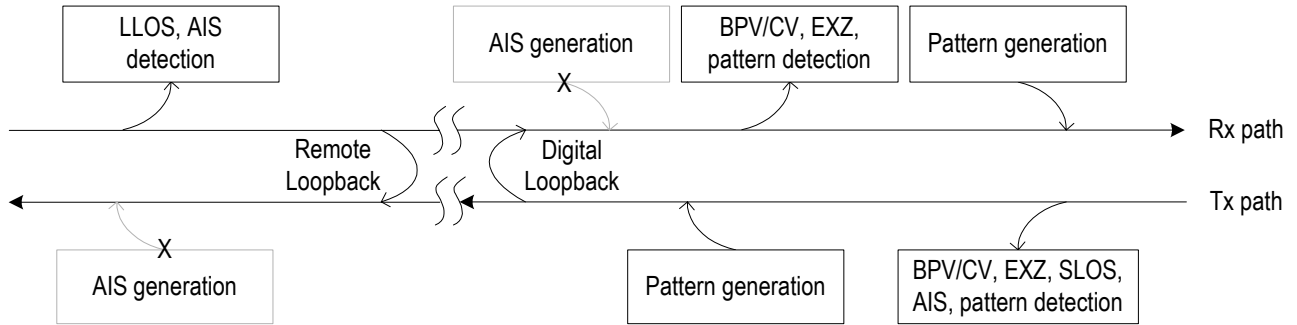

Figure-33 Priority Of Diagnostic Facilities During Manual Remote Loopback + Manual Digital Loopback

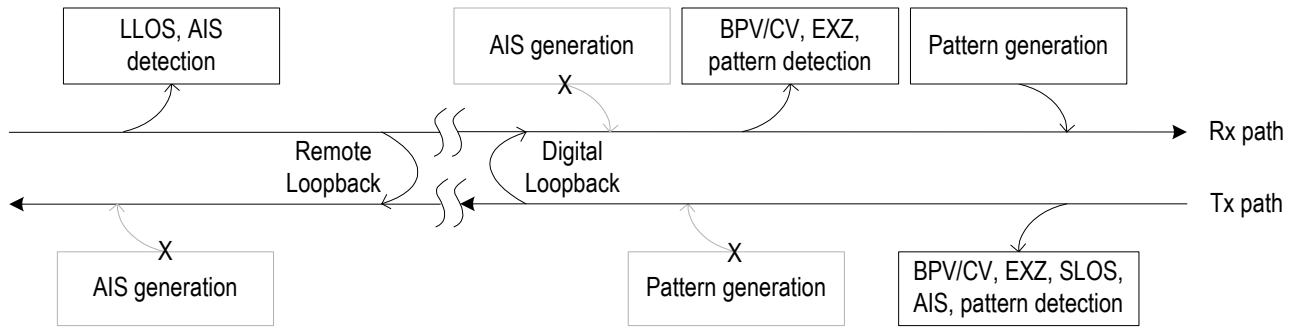

Figure-34 Priority Of Diagnostic Facilities During Manual Remote Loopback + Automatic Digital Loopback

3.4.9 CHANNEL 0 MONITORING

Channel 0 is a special channel. It can be used in normal operation as the other 21 channels, or it can be used as a monitoring channel. Channel 0 supports G.772 Monitoring and Jitter Measurement.

3.4.9.1 G.772 Monitoring

Selected by the MON[5:0] bits (b5~0, MON), any receiver or transmitter of the other 21 channels can be monitored by channel 0 (as shown in Figure-35).

When the G.772 Monitoring is implemented (the MON[5:0] bits (b5~0, MON) is not '0'), the registers of the receiver of channel 0 should be the same as those of the selected receiver /transmitter except the line interface related registers.

Once the G.772 Monitoring is implemented, the receiver of channel 0 switches to External Impedance Matching mode automatically, and the setting in the R_TERM[2:0] bits (b2~0, RCF0,...) of channel 0 is ignored.

During the G.772 Monitoring, channel 0 processes as normal after data is received from the selected path and the operation of the monitored path is not effected.

The signal which is monitored goes through the Clock & Data Recovery of monitoring channel (channel 0). The monitored clock can output on RCLK0. The monitored data can be observed digitally on the output pin of RCLK0, RD0/RDP0 and RDN0. LOS detector is still in use in channel 0 for the monitored signal.

In monitoring mode, channel 0 can be configured to Remote Loop-back. The signal which is being monitored will output on TTIP0 and TRING0. The output signal can then be connected to a standard test equipment for non-intrusive monitoring.

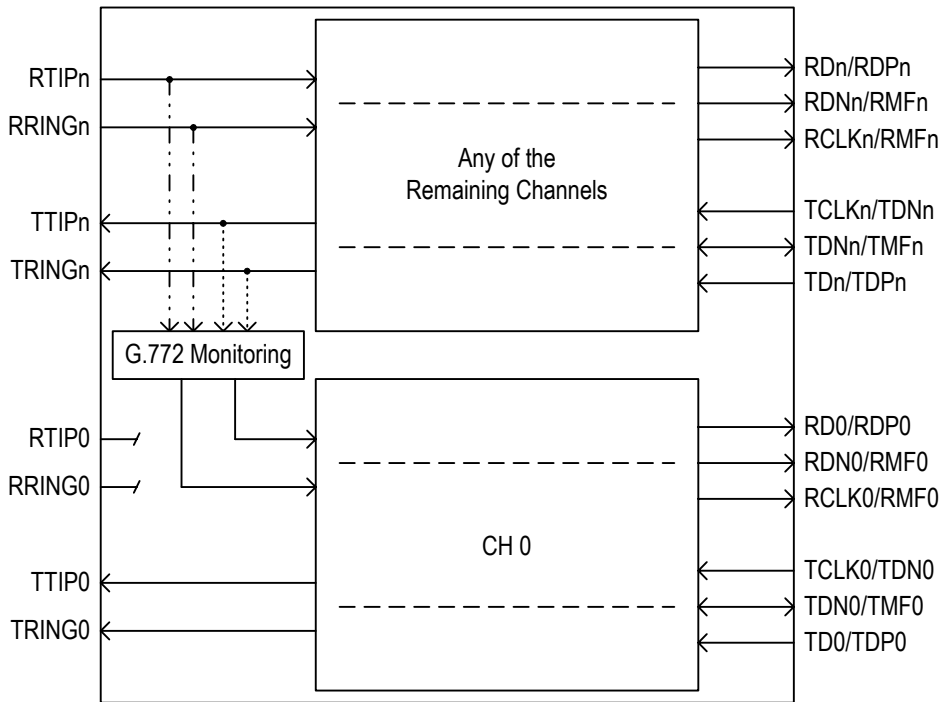

Figure-35 G.772 Monitoring

3.4.9.2 Jitter Measurement (JM)

The RJA of channel 0 consists of a Jitter Measurement (JM) module. When the RJA is enabled in channel 0, the JM is used to measure the positive and negative peak value of the demodulated jitter signal of the received data stream. The bandwidth of the measured jitter is selected by the JM_BW bit (b0, JM).

The greatest positive peak value monitored in a certain period is indicated by the JIT_PH and JIT_PL registers, while the greatest negative peak value monitored in the same period is indicated by the JIT_NH and JIT_NL registers. The relationship between the greatest positive /negative peak value and the indication in the corresponding registers is:

Positive Peak = [JIT_PH, JIT_PL] / 16 (Upp);
 Negative Peak = [JIT_NH, JIT_NL] / 16 (Upp).

The period is determined by the JM_MD bit (b1, JM).

When the JM_MD bit (b1, JM) is '1', the period is one second automatically. The one-second timer uses MCLK as clock reference. The expiration of each one second will set the TMOV_IS bit (b0, INTTM) and induce an interrupt reported by INT if not masked by the TMOV_IM bit (b0, GCF). The TMOV_IS bit (b0, INTTM) is cleared after a '1' is written to this bit. When each one second expires, internal buffers transfer the greatest positive/negative peak value accumulated in this one second to the JIT_PH and JIT_PL / JIT_NH and JIT_NL registers respectively and the internal buffers will be cleared to start a new round measurement. The registers should be read in the next second, otherwise they will be overwritten. Refer to Figure-36 for the process.

When the JM_MD bit (b1, JM) is '0', the period is controlled by the JM_STOP bit (b2, JM) manually. When there is a transition from '0' to '1' on the JM_STOP bit (b2, JM), the internal buffers transfer the greatest positive/negative peak value accumulated in this period to the JIT_PH and JIT_PL / JIT_NH and JIT_NL registers respectively and the internal buffers will be cleared to start a new round measurement. The registers should be read in the next round of jitter measurement, otherwise they will be overwritten. Refer to Figure-37 for the process.

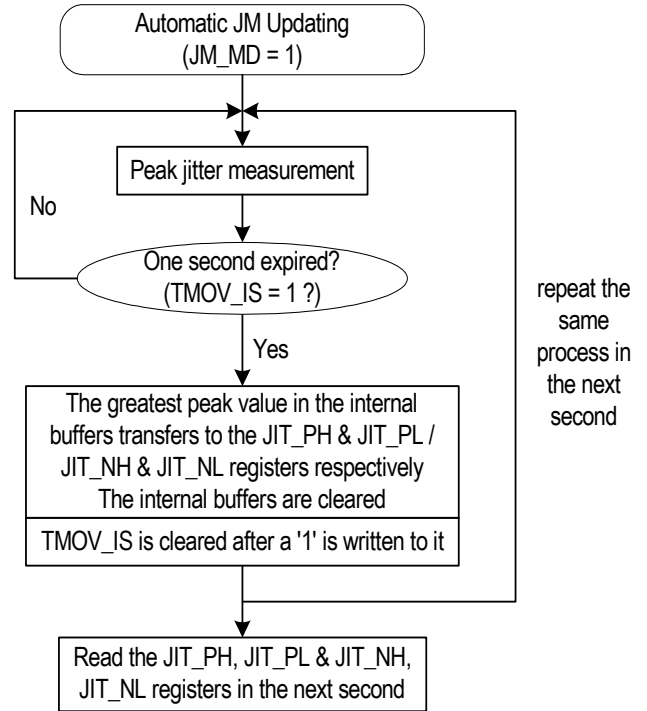

Figure-36 Automatic JM Updating

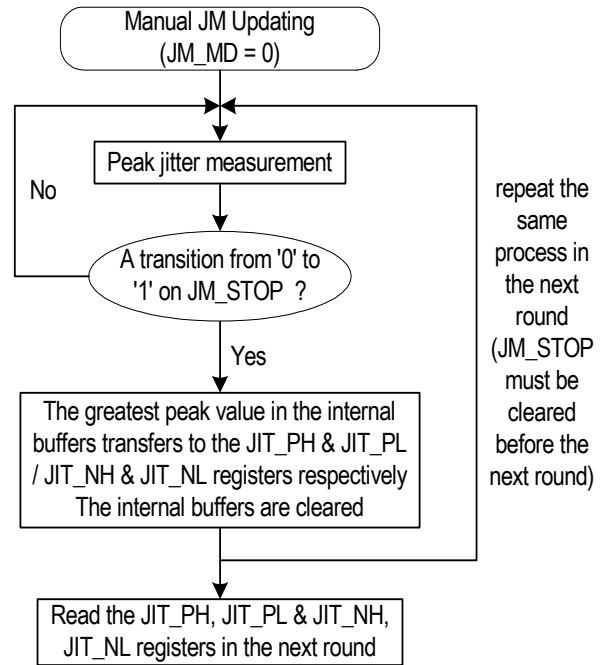

Figure-37 Manual JM Updating

3.5 CLOCK INPUTS AND OUTPUTS

The IDT82P2521 provides two kinds of clock outputs:

- Free running clock outputs on CLKE1
- Receiver clock outputs on REFA and REFB
 - selected from any of the 22 recovered line clocks
 - driven by MCLK (free running)
 - driven by external CLKA/CLKB input

A Frequency Synthesizer is also available to scale REFA to 8 different frequencies.

The following Clock Inputs are provided:

- MCLK as programmable reference timing for the IDT82P2521.
- CLKA and CLKB as optional input clock source for REFA and REFB respectively

3.5.1 FREE RUNNING CLOCK OUTPUTS ON CLKE1

An internal clock generator uses MCLK as reference to generate all the clocks required by internal circuits and CLKE1 outputs. MCLK is a stable jitter-free¹ clock input with ± 50 ppm accuracy. The clock

frequency of MCLK is $2.048 \times N$ MHz ($1 \leq N \leq 8$, N is an integer number), as determined by MCKSEL[3:0]. Refer to Chapter 2 Pin Description for details.

The outputs on CLKE1 is free running (locking to MCLK). The output of CLKE1 is determined by the CLKE1_EN bit (b3, CLKG) and the CLKE1 bit (b2, CLKG). Refer to Table-15.

Table-15 Clock Output on CLKE1

Control Bits		Clock Output On CLKE1
CLKE1_EN	CLKE1	
0	(don't-care)	High-Z
1	0	8 KHz
	1	2.048 KHz

1. Jitter is no more than 0.001 UI.

3.5.2 CLOCK OUTPUTS ON REFA/REFB

The outputs on REFA and REFB can be enabled or disabled, as determined by the REFA_EN bit (b6, REFA) and the REFB_EN bit (b6, REFB) respectively.

When the output is disabled, REFA/REFB is in High-Z state.

When the output is enabled, the output of REFA and REFB varies in different operations. Refer to below for detailed description. Refer to Figure-38 and Figure-39 for an overview of REFA and REFB output options in normal operation.

3.5.2.1 REFA/REFB in Clock Recovery Mode

In this mode (default), the clock of REFA and REFB is derived from the recovered clock of one of the 22 channels as selected by the REFA[4:0] bits (b4~0, REFA) and REFB[4:0] bits (b4~0, REFB). Determined by the FS_BYBYPAS bit (b4, REFCF) a Frequency Synthesizer can be enabled for REFA (refer to Section 3.5.2.2 Frequency Synthesizer for REFA Clock Output). If the Frequency Synthesizer is disabled, REFA will output the recovered 2.048 MHz clock depending on the line mode of the selected channel. REFB output the recovered 2.048 MHz clock depending on the line mode of the selected channel.

The recovered line clock can be output to REFA and REFB before or after it passed the receive Jitter Attenuator (RJA) selected by the JA_BYBYPAS bit (b6, REFCF).

3.5.2.2 Frequency Synthesizer for REFA Clock Output

For REFA a Frequency Synthesizer can be enabled or bypassed (default) as selected by FS_BYBYPASS bit (b4, REFCF). The output frequency is selected by the FREQ[2:0] bits (b2~0, REFCF). Frequencies supported are 8 KHz, 64 KHz, 2.048 MHz, 4.096 MHz, 8.192 MHz, 19.44 MHz or 32.768 MHz.

3.5.2.3 Free Run Mode for REFA Clock Output

REFA can also be selected to provide a free running clock locked to MCLK. To enable this mode the Frequency Synthesizer has to be enabled by setting the FS_BYBYPAS bit (b4, REFCF) to '0', and the FREE bit (b3, REFCF) has to be set to '1'. REFA will provide a frequency selected by the FREQ[2:0]¹ bits (b2~0, REFCF) which is a free running clock locked to MCLK.

3.5.2.4 REFA/REFB Driven by External CLKA/CLKB Input

In this mode, the clock of REFA and REFB is driven from an external clock input of CLKA and CLKB respectively. CLKA and CLKB are selected as an input source by setting REFA[4:0] bits (b4~0, REFA) and REFB[4:0] bits (b4~0, REFB) to any value from '11101' to '11111'.

1. '000' and '011' are reserved for FREQ[2:0] in this mode.

CLKA and CLKB are an external E1 (2.048 MHz) Clock Input. The CKA_E1 bit (b5, REFA) and CKB_E1 bit (b5, REFB) should be set to match the input clock frequency.

Determined by the FS_BYBYPASS bit (b4, REFCF), a Frequency Synthesizer can be enabled for REFA (refer to Section 3.5.2.2 Frequency Synthesizer for REFA Clock Output). If the Frequency Synthesizer is disabled, REFA and REFB will output the 2.048 MHz clock.

3.5.2.5 REFA and REFB in Loss of Signal (LOS) or Loss of Clock Condition

If the recovered clock of one of the 22 channels is selected as the clock source for REFA and REFB (refer to Section 3.5.2.1 REFA/REFB in Clock Recovery Mode) and Line LOS (LLOS) is detected in the corresponding channel, the state of output on REFA and REFB can be selected by the REFH bit (b5, REFCF). If REFH is set to '1', REFA and REFB will output a high level in case of LLOS. If REFH is set to '0' and LLOS is detected, REFA and REFB clock outputs will be locked to MCLK while the selected clock frequency will remain unchanged.

LLOS condition is set when LLOS_S bit (b0, STAT0) is '1'. Refer to Section 3.4.3.1 Line LOS (LLOS).

Refer to Figure-40 for a detailed overview of REFA output in case of LLOS. REFB output option is only determined by the REFH bit (b5, REFCF) to be locked to MCLK or set to high level output.

If CLKA is selected as the clock source for REFA (refer to Section 3.5.2.4 REFA/REFB Driven by External CLKA/CLKB Input) and there is no clock input on CLKA for more than 8 E1 clock cycles if E1 mode is selected (i.e. CKA_E1 bit (b5, REFA) is '1'), the state of the REFA output is determined by the FS_BYBYPAS bit (b4, REFCF) and the FREE bit (b3, REFCF). In case the Frequency Synthesizer is disabled (i.e. FS_BYBYPAS bit (b4, REFCF) is '0'). REFA will output a high level. If the Frequency Synthesizer is enabled and the FREE bit (b3, REFCF) is set to '0', REFA will output a high level. If the Frequency Synthesizer is enabled and the FREE bit (b3, REFCF) is set to '1', REFA will be locked to MCLK.

Refer to Figure-41 for a detailed overview of REFA output in case of loss of CLKA.

If CLKB is selected as the clock source for REFB (refer to section Section 3.5.2.4 REFA/REFB Driven by External CLKA/CLKB Input) and there is no clock input on CLKB for more than 8 E1 clock cycles if E1 mode is selected (i.e. CKB_E1 bit (b5, REFB) is '1'), the output on REFB is determined by the REFH bit (b5, REFCF). If REFH is set to '1', REFB will output a high level. If REFH is set to '0', the REFB clock output will be locked to MCLK.

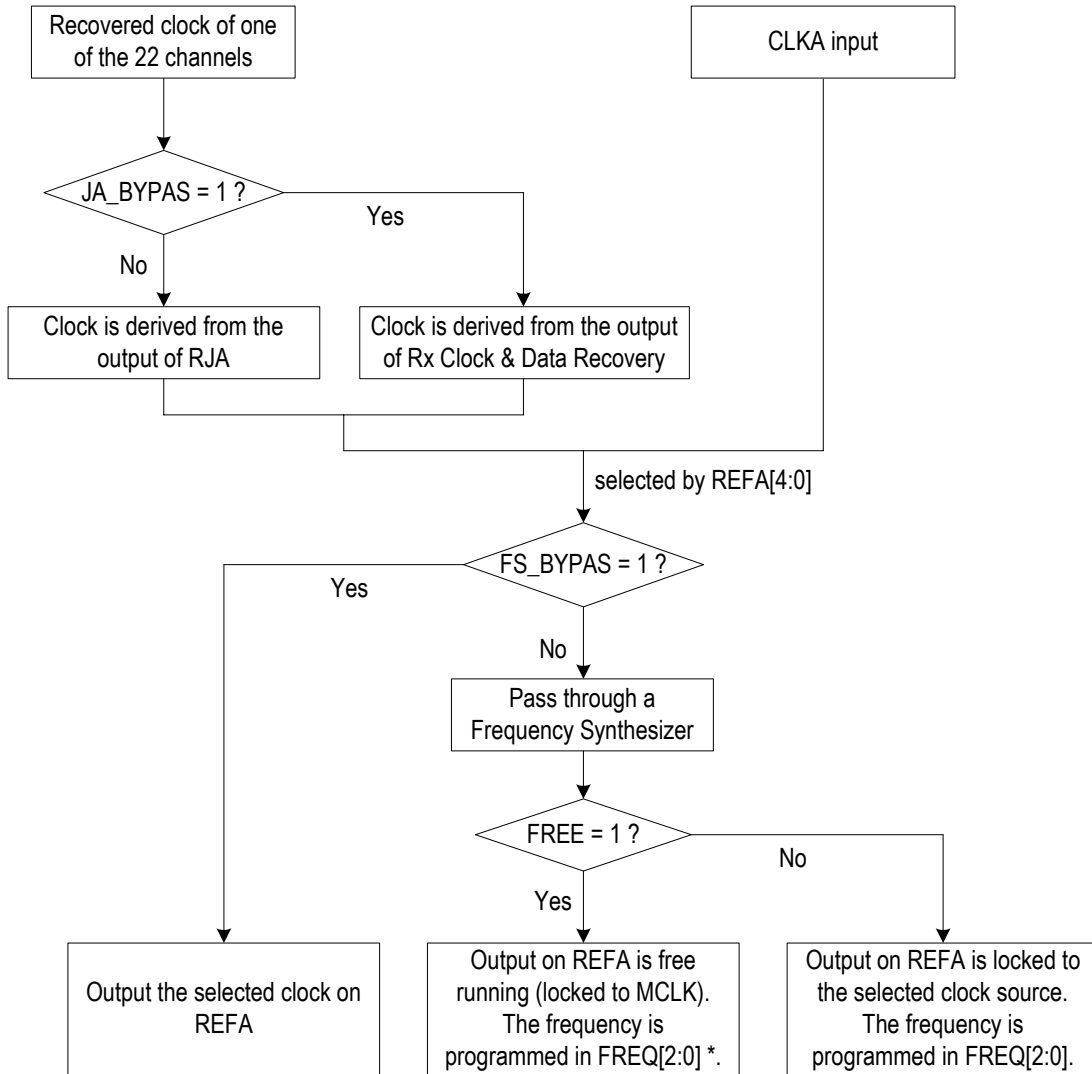

Note *: '000' and '011' are reserved for FREQ[2:0] when REFA is free running.

Figure-38 REFA Output Options in Normal Operation

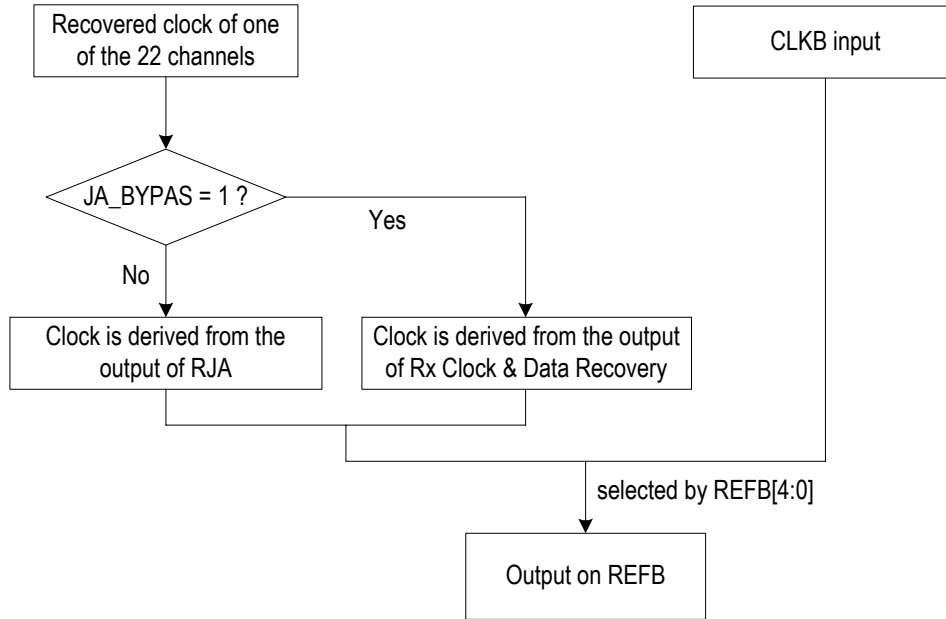
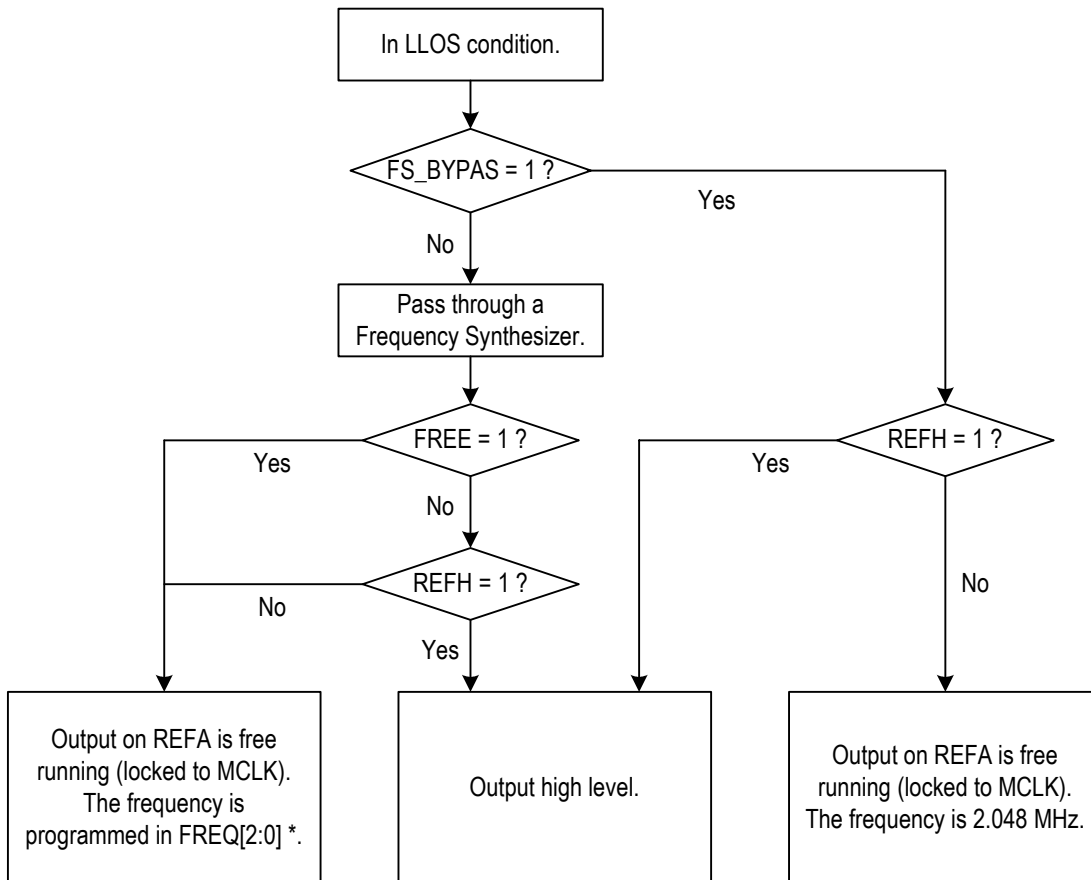
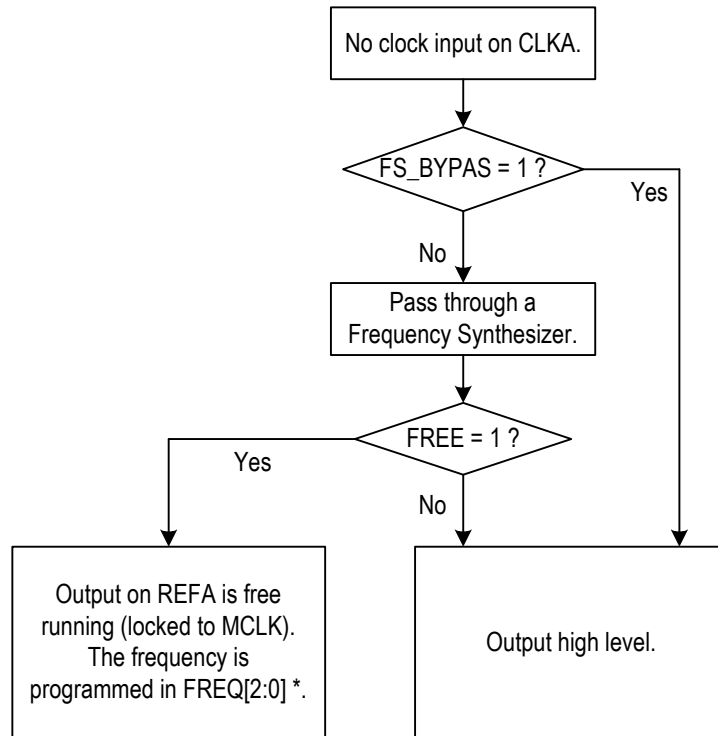

Figure-39 REFB Output Options in Normal Operation



Note *: '000' and '011' are reserved for FREQ[2:0] when REFA is free running.

Figure-40 REFA Output in LLOS Condition (When RCLKn Is Selected)



Note *: '000' and '011' are reserved for FREQ[2:0] when REFA is free running.

Figure-41 REFA Output in No CLKA Condition (When CLKA Is Selected)

3.5.3 MCLK, MASTER CLOCK INPUT

MCLK provides a stable reference timing for the IDT82P2521. MCLK should be a jitter-free¹ clock with ± 50 ppm accuracy. The clock frequency of MCLK is set by pins MCKSEL[3:0] and can be $N \times 2.048$ MHz with $1 \leq N \leq 8$ (N is an integer number). Refer to MCKSEL[3:0] pin description for details.

If there is a loss of MCLK (duty cycle is less than 30% for 10 μ s), the device will enter power down. In this case, both the receive and transmit circuits are turned off. The pins on the line interface will be in High-Z state. The pins on receive system interface will be in High-Z state or in low level, as selected by the RHZ bit (b6, RCF0,...). The input on the

1. Jitter is no more than 0.001 UI.

transmit system interface is ignored and the output on the transmit system interface will be in High-Z state. Refer to Section 3.1.7 Receiver Power Down and Section 3.2.7 Transmitter Power Down for details.

If MCLK recovers after loss of MCLK the device will be reset automatically.

3.5.4 XCLK, INTERNAL REFERENCE CLOCK INPUT

XCLK is derived from MCLK. For the respective channel, it is 2.048 MHz. XCLK is used as selectable reference clock for

- pattern /AIS generation
- RCLKn in LLOS
- Loss of TCLKn to determine Transmit Output High-Z.

3.6 INTERRUPT SUMMARY

There are altogether 20 kinds of interrupt sources as listed in Table-16. Among them, No.1 to No.19 are per-channel interrupt sources, while No. 20 is a global interrupt source.

For interrupt sources from No.1 to No.10, the occurrence of the event will cause the corresponding Status bit to be set to '1'. And selected by the Interrupt Trigger Edges Select bit, either a transition from '0' to '1' or any transition from '0' to '1' or from '1' to '0' of the Status bit will cause the Interrupt Status bit to be set to '1', which indicates the occurrence of an interrupt event.

For interrupt sources from No.11 to No.20, the occurrence of the event will cause the corresponding Interrupt Status Bit to be set to '1'.

All the interrupt can be masked by the GLB_IM bit (b1, GCF) globally or by the corresponding interrupt mask bit individually. For all the interrupt sources, if not masked, the occurrence of the interrupt event will trigger an interrupt indicated by the \overline{INT} pin. For per-channel interrupt sources, if not masked, the occurrence of the interrupt event will also cause the corresponding INT_CHn bit (INTCH1~4) to be set '1'.

An interrupt event is cleared by writing '1' to the corresponding Interrupt Status bit. The INT_CHn bit (INTCH1~4) will not be cleared until all the interrupts in the corresponding channel are acknowledged. The \overline{INT} pin will be inactive until all the interrupts are acknowledged. Refer to Figure-42 for interrupt service flow.

Table-16 Interrupt Summary

No.	Interrupt Source	Status Bit	Interrupt Trigger Edges Select Bit	Interrupt Status Bit	Interrupt Mask Bit
1	TCLKn is missing.	TCKLOS_S (b3, STAT0,...)	TCKLOS_IES (b3, INTES,...)	TCKLOS_IS (b3, INTS0,...)	TCKLOS_IM (b3, INTM0,...)
2	LLOS is detected.	LLOS_S (b0, STAT0,...)	LOS_IES (b1, INTES,...)	LLOS_IS (b0, INTS0,...)	LLOS_IM (b0, INTM0,...)
3	SLOS is detected.	SLOS_S (b1, STAT0,...)	LOS_IES (b1, INTES,...)	SLOS_IS (b1, INTS0,...)	SLOS_IM (b1, INTM0,...)
4	TLOS is detected.	TLOS_S (b2, STAT0,...)	TLOS_IES (b2, INTES,...)	TLOS_IS (b2, INTS0,...)	TLOS_IM (b2, INTM0,...)
5	LAIS is detected.	LAIS_S (b6, STAT1,...)	AIS_IES (b6, INTES,...)	LAIS_IS (b6, INTS1,...)	LAIS_IM (b6, INTM1,...)
6	SAIS is detected.	SAIS_S (b7, STAT1,...)	AIS_IES (b6, INTES,...)	SAIS_IS (b7, INTS1,...)	SAIS_IM (b7, INTM1,...)
7	TOC is detected.	TOC_S (b4, STAT0,...)	TOC_IES (b4, INTES,...)	TOC_IS (b4, INTS0,...)	TOC_IM (b4, INTM0,...)
8	The PRBS/ARB pattern is detected synchronized.	PA_S (b5, STAT1,...)	PA_IES (b5, INTES,...)	PA_IS (b5, INTS1,...)	PA_IM (b5, INTM1,...)
9	Activate IB code is detected.	IBA_S (b1, STAT1,...)	IB_IES (b0, INTES,...)	IBA_IS (b1, INTS1,...)	IBA_IM (b1, INTM1,...)
10	Deactivate IB code is detected.	IBD_S (b0, STAT1,...)	IB_IES (b0, INTES,...)	IBD_IS (b0, INTS1,...)	IBD_IM (b0, INTM1,...)
11	The FIFO of the RJA is overflow or underflow.	-	-	RJA_IS (b5, INTS0,...)	RJA_IM (b5, INTM0,...)
12	The FIFO of the TJA is overflow or underflow.	-	-	TJA_IS (b6, INTS0,...)	TJA_IM (b6, INTM0,...)
13	Waveform amplitude is overflow.	-	-	DAC_IS (b7, INTS0,...)	DAC_IM (b7, INTM0,...)
14	SBPV is detected.	-	-	SBPV_IS (b5, INTS2,...)	SBPV_IM (b5, INTM2,...)
15	LBPV is detected.	-	-	LBPV_IS (b4, INTS2,...)	LBPV_IM (b4, INTM2,...)
16	SEXZ is detected.	-	-	SEXZ_IS (b3, INTS2,...)	SEXZ_IM (b3, INTM2,...)
17	LEXZ is detected.	-	-	LEXZ_IS (b2, INTS2,...)	LEXZ_IM (b2, INTM2,...)
18	PRBS/ARB error is detected.	-	-	ERR_IS (b1, INTS2,...)	ERR_IM (b1, INTM2,...)
19	The ERRCH and ERRCL registers are overflowed.	-	-	CNTOV_IS (b0, INTS2,...)	CNTOV_IM (b0, INTM2,...)
20	One second time is over.	-	-	TMOV_IS (b0, INTTM)	TMOV_IM (b0, GCF)

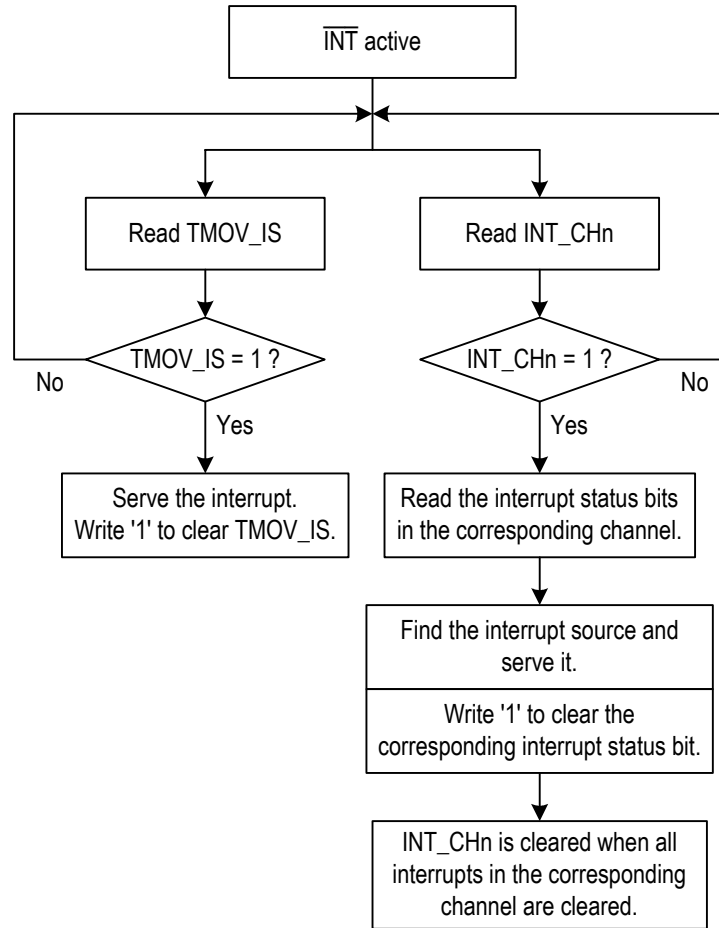

Figure-42 Interrupt Service Process

4 MISCELLANEOUS

4.1 RESET

The reset operation resets all registers, state machines as well as I/O pins to their default value or status.

The IDT82P2521 provides 4 kinds of reset:

- Power-on reset;
- Hardware reset;
- Global software reset;
- Per-channel software reset.

The Power-on, Hardware and Global software reset operations reset all the common blocks (including clock generator/synthesizer and microprocessor interface) and channel-related parts. The Per-channel software reset operation resets the channel-related parts. Figure-43 shows a general overview of the reset options.

During reset, all the line interface pins (i.e., TTIPn/TRINGn and RTIPn/RRINGn) are in High-Z state.

After reset, all the items listed in Table-17 are true.

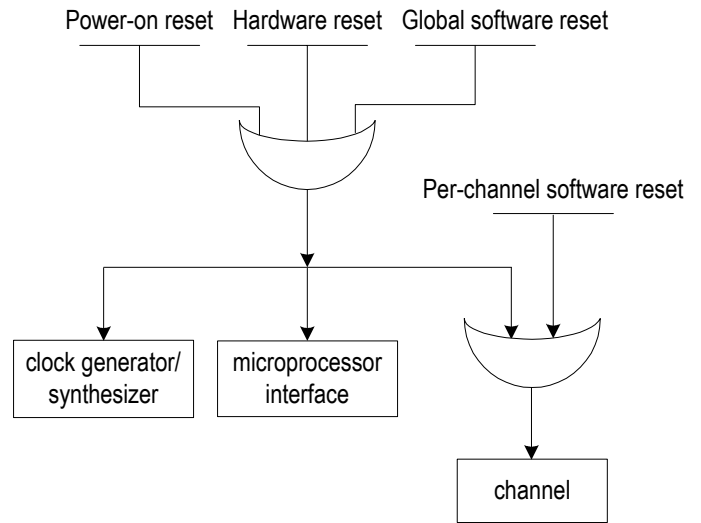

Figure-43 Reset

Table-17 After Reset Effect Summary

Effect On ...	Power-On Reset, Hardware Reset and Global Software Reset	Per-Channel Software Reset
TTIPn/TRINGn & RTIPn/RRINGn	All TTIPn/TRINGn & RTIPn/RRINGn pins are in High-Z state.	Only TTIPn/TRINGn & RTIPn/RRINGn in the corresponding channel are in High-Z.
Line Interface Mode	Not E1 mode.	Not E1 mode.
System interface	All channels are in Dual Rail NRZ Format.	Only the corresponding channel is in Dual Rail NRZ Format.
General I/O pins (i.e., D[7:0] and GPIO[1:0])	As input pins.	(No effect)
INT	Open drain output.	(No effect)
CLKE1, REFA, REFB	Output enable.	(No effect)
LLOS, LLOS0	Output enable.	(No effect)
TDO, SDO/ACK/RDY	High-Z.	(No effect)
state machines	All state machines are reset.	The state machines in the corresponding channel are reset.
Interrupt sources	All interrupt sources are masked.	The interrupt sources in the corresponding channel are masked.
Registers	All registers are reset to their default value.	The registers in the corresponding channel are reset to their default value except that there is no effect on the E1 bit.

4.1.1 POWER-ON RESET

Power-on reset is initiated during power-up. When all VDD inputs (1.8V and 3.3V) reach approximately 60% of the standard value of VDD, power-on reset begins. If MCLK is applied, power-on reset will complete within 1 ms maximum; if MCLK is not applied, the device remains in reset state.

4.1.2 HARDWARE RESET

Pulling the $\overline{\text{RST}}$ pin to low will initiate hardware reset. The reset cycle should be more than 1 μs . If the $\overline{\text{RST}}$ pin is held low continuously, the device remains in reset state.

4.1.3 GLOBAL SOFTWARE RESET

Writing the RST register will initiate global software reset. Once initiated, global software reset completes in 1 μs maximum.

4.1.4 PER-CHANNEL SOFTWARE RESET

Writing a '1' to the CHRST bit (b1, CHCF,...) will initiate per-channel software reset. Once initiated, per-channel software reset completes in 1 μs maximum and the CHRST bit (b1, CHCF,...) is self cleared.

This reset is different from other resets, for:

- It does not reset the global registers, state machines and common pins (including the pins of clock generator, microprocessor interface and JTAG interface);
- It does not reset the other channels.

4.2 MICROPROCESSOR INTERFACE

The microprocessor interface provides access to read and write the registers in the device. The interface consists of:

- Serial microprocessor interface;
- Parallel Motorola Non-Multiplexed microprocessor interface;
- Parallel Motorola Multiplexed microprocessor interface;
- Parallel Intel Non-Multiplexed microprocessor interface;
- Parallel Intel Multiplexed microprocessor interface.

The microprocessor interface is selected by the $\overline{\text{P/S}}$, $\overline{\text{INT/MOT}}$ and IM pins, as shown in Table-18. The interfaced pins in different interfaces are also listed in Table-18. Refer to Section 8.11 Microprocessor Interface Timing for the timing characteristics.

Table-18 Microprocessor Interface

$\overline{\text{P/S}}$	$\overline{\text{INT/MOT}}$	IM	Microprocessor Interface	Interfaced Pins
GNDD	Open	GNDD	Serial microprocessor interface	$\overline{\text{CS}}$, SCLK, SDI, SDO
VDDIO	GNDD	GNDD	Parallel Motorola Non-Multiplexed microprocessor interface	$\overline{\text{CS}}$, $\overline{\text{DS}}$, $\overline{\text{R/W}}$, $\overline{\text{ACK}}$, D[7:0], A[10:0]
		Open	Parallel Motorola Multiplexed microprocessor interface	$\overline{\text{CS}}$, AS, $\overline{\text{DS}}$, $\overline{\text{R/W}}$, $\overline{\text{ACK}}$, D[7:0], A[10:8]
	Open	GNDD	Parallel Intel Non-Multiplexed microprocessor interface	$\overline{\text{CS}}$, $\overline{\text{RD}}$, $\overline{\text{WR}}$, RDY, D[7:0], A[10:0]
		Open	Parallel Intel Multiplexed microprocessor interface	$\overline{\text{CS}}$, ALE, $\overline{\text{RD}}$, $\overline{\text{WR}}$, RDY, D[7:0], A[10:8]

4.3 POWER UP

No power up sequencing for the VDD inputs (1.8 V and 3.3 V) has to be provided for the IDT82P2521. A Power-on reset will be initiated during power up. Refer to Section 4.1 Reset.

4.4 HITLESS PROTECTION SWITCHING (HPS) SUMMARY

In today's telecommunication systems, ensuring no traffic loss is becoming increasingly important. To combat these problems, redundancy protection must be built into the systems carrying this traffic. There are many types of redundancy protection schemes, including 1+1 and 1:1 hardware protection without the use of external relays. Refer to

Figure-44, Figure-45 and Figure-46 for different protection schemes. The IDT82P2521 provides an enhanced architecture to support both protection schemes.

IDT82P2521 highlights for HPS support:

- Independent programmable receive and transmit high impedance for Tip and Ring inputs and outputs to support 1+1 and 1:1 redundancy
- Fully integrated receive termination, required to support 1:1 redundancy
- Enhanced internal architecture to guarantee High Impedance for Tip and Ring Inputs and Outputs during Power Off or Power Failure
- Asynchronous hardware control (OE, RIM) for fast global high impedance of receiver and transmitter (hot switching between working and backup board)

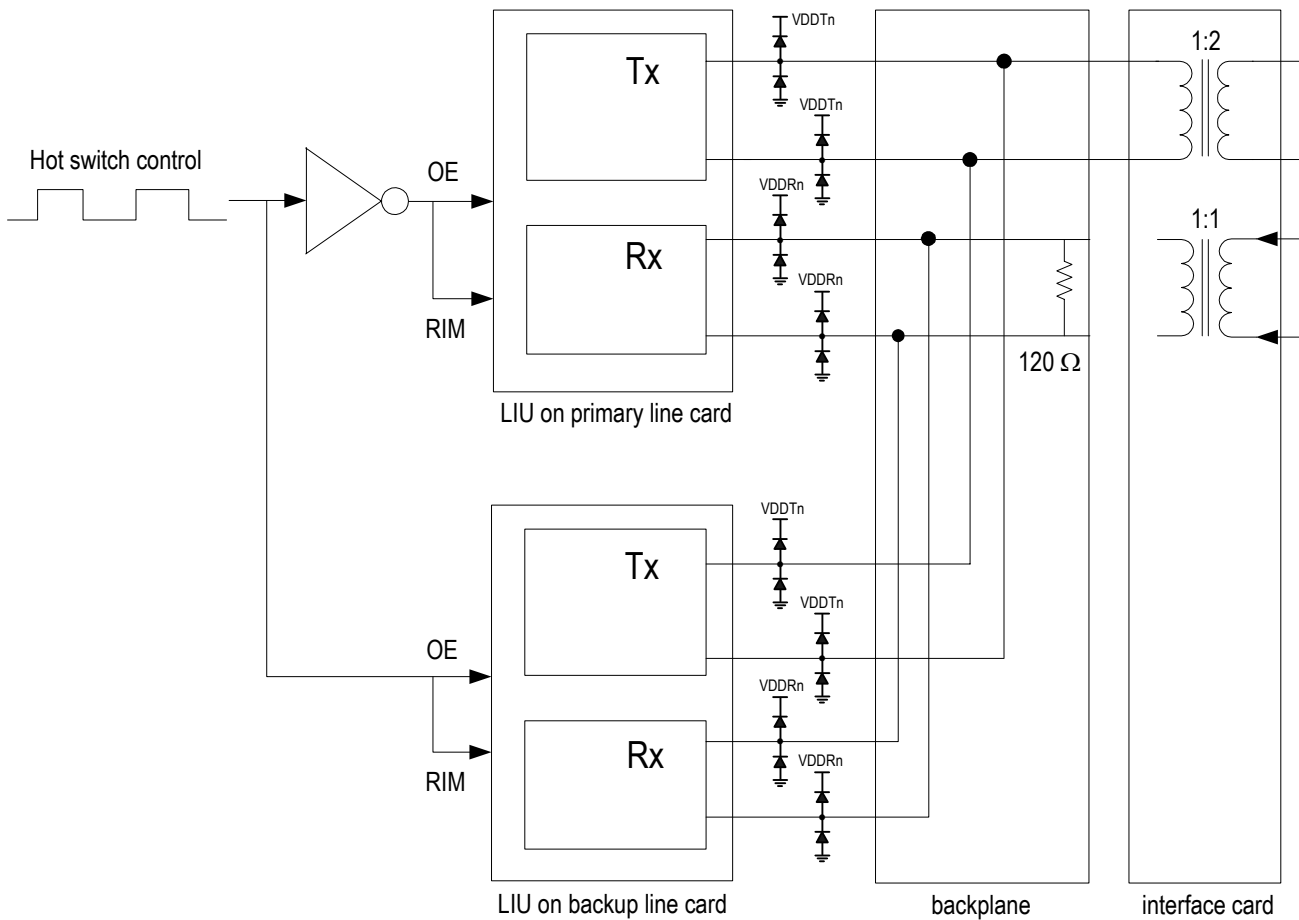

Rx: Partially Internal Impedance Matching mode. A fixed external 120 Ω resistor is placed on the backplane and provides a common termination for E1 applications. The R_TERM[2:0] bits (b2~0, RCF0,...) setting is as follows: '010' for E1 120 Ω twisted pair cable and '011' for E1 75 Ω coaxial cable.

Tx: Internal Impedance Matching mode. The T_TERM[2:0] bits (b2~0, TCF0,...) setting is as follows: '010' for E1 120 Ω twisted pair cable and '011' for E1 75 Ω coaxial cable.

Figure-44 1+1 HPS Scheme, Differential Interface (Shared Common Transformer)

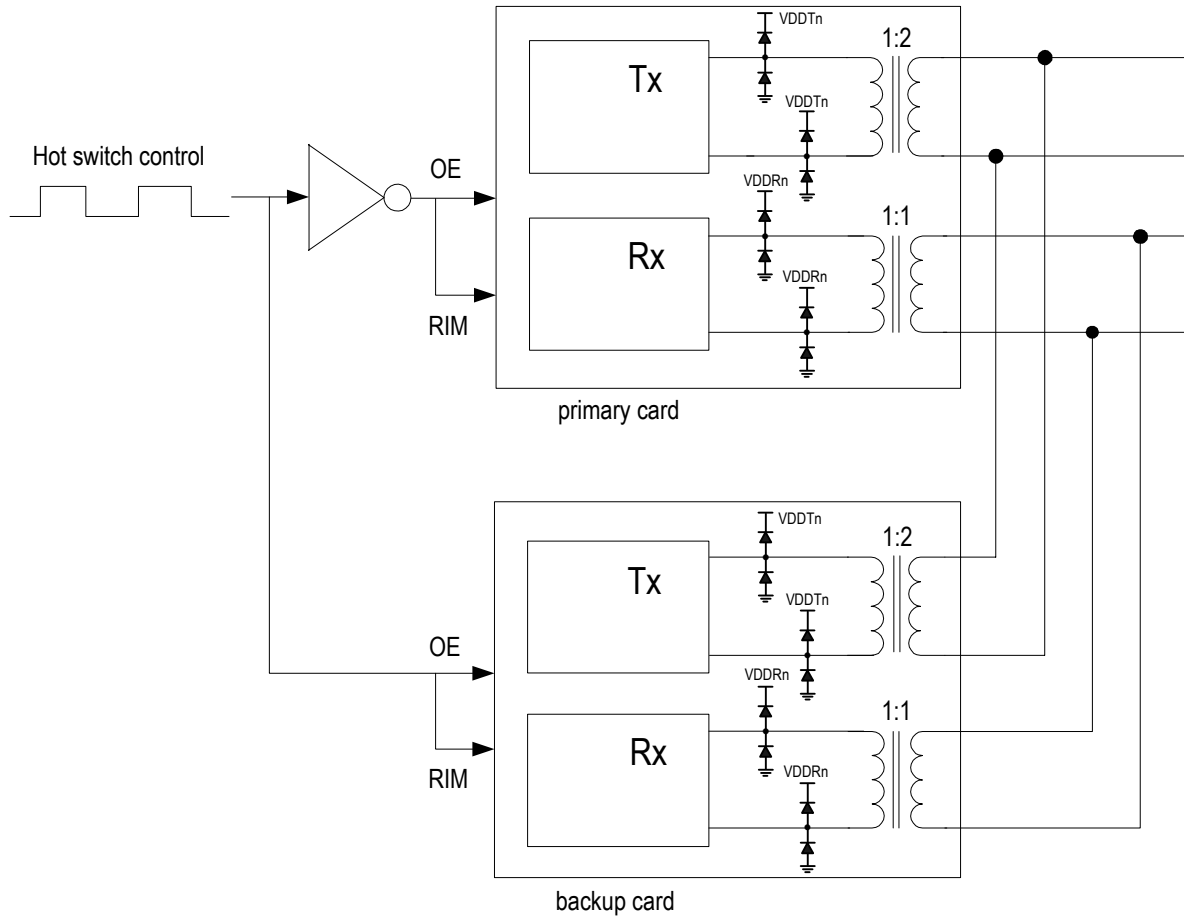

Rx: Fully Internal Impedance Matching mode. In this mode, there is no external resistor required. The R_TERM[2:0] bits (b2~0, RCF0,...) setting is as follows: '010' for E1 120 Ω twisted pair cable and '011' for E1 75 Ω coaxial cable.

Tx: Internal Impedance Matching mode. The T_TERM[2:0] bits (b2~0, TCF0,...) setting is as follows: '010' for E1 120 Ω twisted pair cable and '011' for E1 75 Ω coaxial cable.

Figure-45 1:1 HPS Scheme, Differential Interface (Individual Transformer)

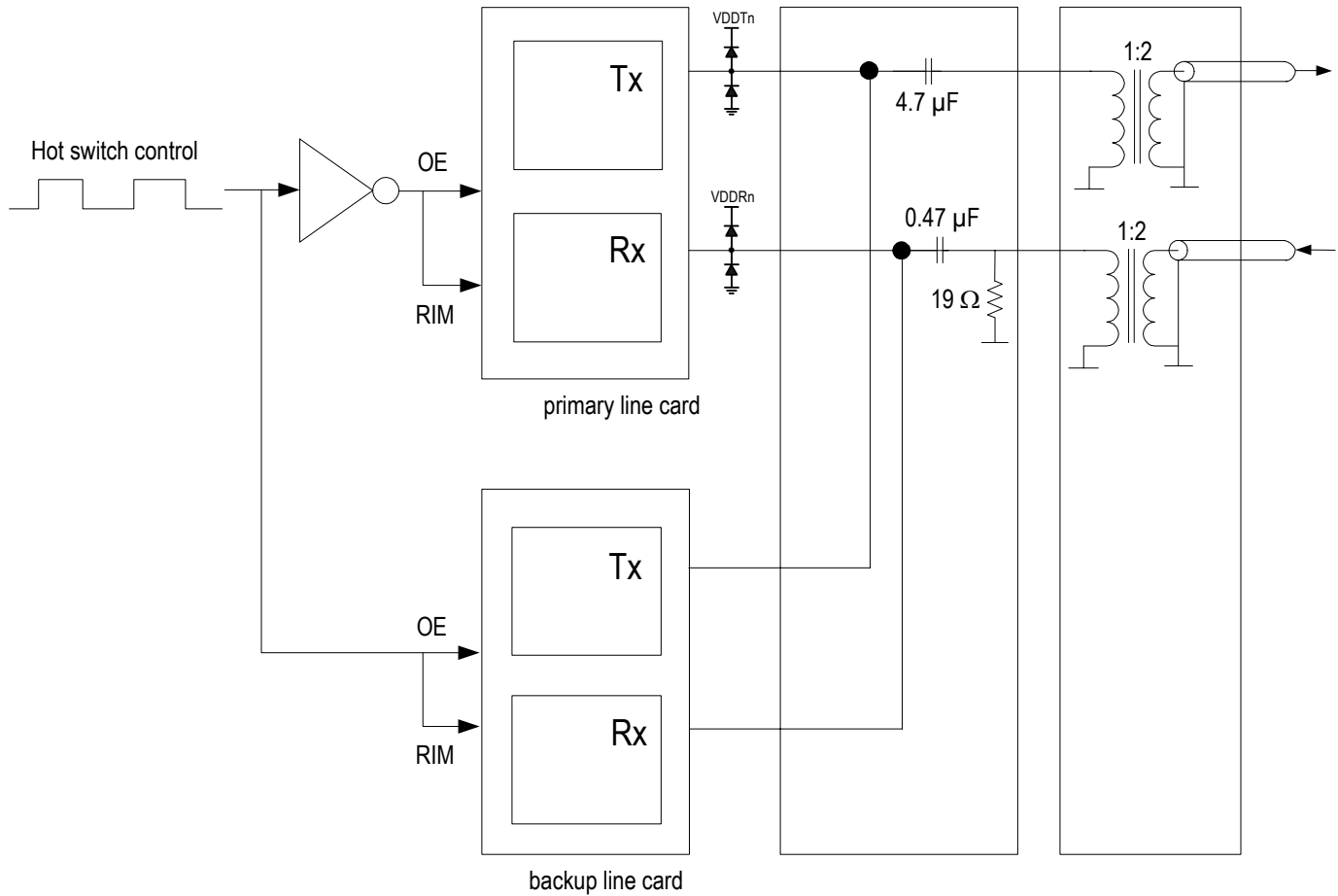

Rx: 75 Ω External Impedance Matching mode. In this mode, there is no external resistor required. The RIM pin should be left open and the configuration of the R_TERM[2:0] bits (b2~0, RCF0,...) is ignored.

Tx: 75 Ω Internal Impedance Matching mode. The T_TERM[2:0] bits (b2~0, TCF0,...) should be set to '011'.

Figure-46 1+1 HPS Scheme, E1 75 ohm Single-Ended Interface (Shared Common Transformer)

5 PROGRAMMING INFORMATION

5.1 REGISTER MAP

5.1.1 GLOBAL REGISTER

Address (Hex)	Register Name	Bit 7	Bit 6	Bit 5	Bit 4	Bit 3	Bit 2	Bit 1	Bit 0	Reference Page
<i>Common Control</i>										
000	ID - Device ID Register	ID7	ID6	ID5	ID4	ID3	ID2	ID1	ID0	P 77
040	RST - Global Reset Register	RST7	RST6	RST5	RST4	RST3	RST2	RST1	RST0	P 77
080	GCF - Global Configuration Register	-	-	-	COPY	INT_PIN1	INT_PIN0	GLB_IM	TMOV_IM	P 78
0C0	MON - G.772 Monitor Configuration Register	-	-	MON5	MON4	MON3	MON2	MON1	MON0	P 79
100	GPIO - General Purpose I/O Pin Definition Register	-	-	-	-	LEVEL1	LEVEL0	DIR1	DIR0	P 80
<i>Reference Clock Timing Option</i>										
1C0	CLKG - CLKE1 Generation Control Register	-	-	-	-	CLKE1_EN	CLKE1	-	-	P 80
200	REFCF - REFA/B Output Configuration Register	-	JA_BYPAS	REFH	FS_BYPAS	FREE	FREQ2	FREQ1	FREQ0	P 81
240	REFA - REFA Clock Sources Configuration Register	-	REFA_EN	CKA_E1	REFA4	REFA3	REFA2	REFA1	REFA0	P 83
280	REFB - REFB Clock Sources Configuration Register	-	REFB_EN	CKB_E1	REFB4	REFB3	REFB2	REFB1	REFB0	P 83
<i>Interrupt Indication</i>										
2C0	INTCH1 - Interrupt Requisition Source Register 1	INT_CH8	INT_CH7	INT_CH6	INT_CH5	INT_CH4	INT_CH3	INT_CH2	INT_CH1	P 84
300	INTCH2 - Interrupt Requisition Source Register 2	INT_CH16	INT_CH15	INT_CH14	INT_CH13	INT_CH12	INT_CH11	INT_CH10	INT_CH9	P 84
340	INTCH3 - Interrupt Requisition Source Register 3	-	-	-	INT_CH21	INT_CH20	INT_CH19	INT_CH18	INT_CH17	P 84
380	INTCH4 - Interrupt Requisition Source Register 4	INT_CH0	-	-	-	-	-	-	-	P 85
3C0	INTTM - One Second Timer Interrupt Status Register	-	-	-	-	-	-	-	TMOV_IS	P 85

5.1.2 PER-CHANNEL REGISTER

Except for registers 7E5~7E9, which are channel 0 related registers, only the address of channel 1 is listed in the 'Address (Hex)' column of the following table. For the addresses of the other channels, refer to the description of each register.

Address (Hex)	Register Name	Bit 7	Bit 6	Bit 5	Bit 4	Bit 3	Bit 2	Bit 1	Bit 0	Reference Page
<i>Channel Control</i>										
001	CHCF - Channel Configuration Register	-	-	-	-	-	-	CHRST	-	P 85
<i>JA Configuration</i>										
002	TJA - Transmit Jitter Attenuation Configuration Register	-	-	-	TJA_LIMT	TJA_EN	TJA_DP1	TJA_DP0	TJA_BW	P 86
003	RJA - Receive Jitter Attenuation Configuration Register				RJA_LIMT	RJA_EN	RJA_DP1	RJA_DP0	RJA_BW	P 87
<i>Transmit Path Configuration</i>										
004	TCF0 - Transmit Configuration Register 0	-	OE	T_OFF	THZ_OC	T_SING	T_TERM2	T_TERM1	T_TERM0	P 88
005	TCF1 - Transmit Configuration Register 1	TMF_DEF2	TEM_DEF1	TMF_DEF0	TCK_ES	TD_INV	T_CODE	T_MD1	T_MD0	P 89
006	PULS - Transmit Pulse Configuration Register	-	-	-	-	PULS3	PULS2	PULS1	PULS0	P 90
007	SCAL - Amplitude Scaling Control Register	-	-	SCAL5	SCAL4	SCAL3	SCAL2	SCAL1	SCAL0	P 91
008	AWG0 - Arbitrary Waveform Generation Control Register 0	-	DONE	RW	SAMP4	SAMP3	SAMP2	SAMP1	SAMP0	P 91
009	AWG1 - Arbitrary Waveform Generation Control Register 1	-	WDAT6	WDAT5	WDAT4	WDAT3	WDAT2	WDAT1	WDAT0	P 92
<i>Receive Path Configuration</i>										
00A	RCF0 - Receive Configuration Register 0	RCKH	RHZ	R_OFF	R120IN	R_SING	R_TERM2	R_TERM1	R_TERM0	P 93
00B	RCF1 - Receive Configuration Register 1	RMF_DEF2	RMF_DEF1	RMF_DEF0	RCK_ES	RD_INV	R_CODE	R_MD1	R_MD0	P 94
00C	RCF2 - Receive Configuration Register 2	-	-	-	-	-	-	MG1	MG0	P 95
<i>Diagnostics</i>										
00D	LOS - LOS Configuration Register	LAC	ALOS2	ALOS1	ALOS0	TALOS1	TALOS0	TDLOS1	TDLOS0	P 96
00E	ERR - Error Detection & Insertion Control Register	EXZ_DEF	BPV_INS	ERR_INS	CNT_SEL2	CNT_SEL1	CNT_SEL0	CNT_MD	CNT_STOP	P 97
00F	AISG - AIS Generation Control Register	-	-	-	-	AS AIS_SL OS	AS AIS_LLO S	AL AIS_SLO S	AL AIS_LLO S	P 98
010	PG - Pattern Generation Control Register	-	PG_CK	PG_EN1	PG_EN0	PG_POS	PAG_INV	PRBG_SEL 1	PRBG_SEL 0	P 99

Address (Hex)	Register Name	Bit 7	Bit 6	Bit 5	Bit 4	Bit 3	Bit 2	Bit 1	Bit 0	Reference Page
011	PD - Pattern Detection Control Register	-	-	-	-	PD_POS	PAD_INV	PAD_SEL1	PAD_SEL0	P 100
012	ARBL - Arbitrary Pattern Generation / Detection Low-Byte Register	ARB7	ARB6	ARB5	ARB4	ARB3	ARB2	ARB1	ARB0	P 101
013	ARBM - Arbitrary Pattern Generation / Detection Middle-Byte Register	ARB15	ARB14	ARB13	ARB12	ARB11	ARB10	ARB9	ARB8	P 101
014	ARBH - Arbitrary Pattern Generation / Detection High-Byte Register	ARB23	ARB22	ARB21	ARB20	ARB19	ARB18	ARB17	ARB16	P 101
015	IBL - Inband Loopback Control Register	-	-	IBGL1	IBGL0	IBAL1	IBAL0	IBDL1	IBDL0	P 102
016	IBG - Inband Loopback Generation Code Definition Register	IBG7	IBG6	IBG5	IBG4	IBG3	IBG2	IBG1	IBG0	P 102
017	IBDA - Inband Loopback Detection Target Activate Code Definition Register	IBA7	IBA6	IBA5	IBA4	IBA3	IBA2	IBA1	IBA0	P 103
018	IBDD - Inband Loopback Detection Target Deactivate Code Definition Register	IBD7	IBD6	IBD5	IBD4	IBD3	IBD2	IBD1	IBD0	P 103
019	LOOP - Loopback Control Register	-	-	-	-	AUTOLP	DLP	RLP	ALP	P 104
<i>Interrupt Edge Selection</i>										
01A	INTES - Interrupt Trigger Edges Select Register	-	AIS_IES	PA_IES	TOC_IES	TCKLOS_IES	TLOS_IES	LOS_IES	IB_IES	P 105
<i>Interrupt Mask</i>										
01B	INTM0 - Interrupt Mask Register 0	DAC_IM	TJA_IM	RJA_IM	TOC_IM	TCKLOS_IM	TLOS_IM	SLOS_IM	LLOS_IM	P 106
01C	INTM1 - Interrupt Mask Register 1	SAIS_IM	LAIS_IM	PA_IM	-	-	-	IBA_IM	IBD_IM	P 107
01D	INTM2 - Interrupt Mask Register 2	-	-	SBPV_IM	LBPV_IM	SEXZ_IM	LEXZ_IM	ERR_IM	CNTOV_IM	P 108
<i>Status Indication</i>										
01E	STAT0 - Status Register 0	AUTOLP_S	-	-	TOC_S	TCKLOS_S	TLOS_S	SLOS_S	LLOS_S	P 109
01F	STAT1 - Status Register 1	SAIS_S	LAIS_S	PA_S	-	-	-	IBA_S	IBD_S	P 110
<i>Interrupt Status Indication</i>										
020	INTS0 - Interrupt Status Register 0	DAC_IS	TJA_IS	RJA_IS	TOC_IS	TCKLOS_IS	TLOS_IS	SLOS_IS	LLOS_IS	P 111
021	INTS1 - Interrupt Status Register 1	SAIS_IS	LAIS_IS	PA_IS	-	-	-	IBA_IS	IBD_IS	P 112
022	INTS2 - Interrupt Status Register 2	-	-	SBPV_IS	LBPV_IS	SEXZ_IS	LEXZ_IS	ERR_IS	CNTOV_IS	P 113

Address (Hex)	Register Name	Bit 7	Bit 6	Bit 5	Bit 4	Bit 3	Bit 2	Bit 1	Bit 0	Reference Page
<i>Counter</i>										
023	ERRCL - Error Counter Low-Byte Register	ERRC7	ERRC6	ERRC5	ERRC4	ERRC3	ERRC2	ERRC1	ERRC0	P 114
024	ERRCH - Error Counter High-Byte Register	ERRC15	ERRC14	ERRC13	ERRC12	ERRC11	ERRC10	ERRC9	ERRC8	P 114
<i>Jitter Measurement (channel 0 Only)</i>										
7E5	JM - Jitter Measurement Configuration For Channel 0 Register	-	-	-	-	-	JM_STOP	JM_MD	JM_BW	P 115
7E6	JIT_PL - Positive Peak Jitter Measurement Low-Byte Register	JIT_P7	JIT_P6	JIT_P5	JIT_P4	JIT_P3	JIT_P2	JIT_P1	JIT_P0	P 115
7E7	JIT_PH - Positive Peak Jitter Measurement High-Byte Register	-	-	-	-	JIT_P11	JIT_P10	JIT_P9	JIT_P8	P 115
7E8	JIT_NL - Negative Peak Jitter Measurement Low-Byte Register	JIT_N7	JIT_N6	JIT_N5	JIT_N4	JIT_N3	JIT_N2	JIT_N1	JIT_N0	P 116
7E9	JIT_NH - Negative Peak Jitter Measurement High-Byte Register	-	-	-	-	JIT_N11	JIT_N10	JIT_N9	JIT_N8	P 116

5.2 REGISTER DESCRIPTION

5.2.1 GLOBAL REGISTER

ID - Device ID Register

Address: 000H Type: Read Default Value: 20H							
7	6	5	4	3	2	1	0
ID7	ID6	ID5	ID4	ID3	ID2	ID1	ID0
Bit	Name	Description					
7 - 0	ID[7:0]	The ID[7:0] bits are pre-set. The ID[7:4] bits represent the device ID for the IDT82P2521. The ID[3:0] bits represent the current version number ('0000' is for the first version).					

RST - Global Reset Register

Address: 040H Type: Write Default Value: 00H							
7	6	5	4	3	2	1	0
RST7	RST6	RST5	RST4	RST3	RST2	RST1	RST0
Bit	Name	Description					
7 - 0	RST[7:0]	Writing this register will initiate global software reset. This reset completes in 1 μ s maximum.					

GCF - Global Configuration Register

Address: 080H							
Type: Read / Write							
Default Value: 03H							
7	6	5	4	3	2	1	0
-	-	-	COPY	INT_PIN1	INT_PIN0	GLB_IM	TMOV_IM
Bit	Name	Description					
7 - 5	-	Reserved.					
4	COPY	When the per-channel register of one channel is written, this bit determines whether the written value is copied to the same register of the other channels simultaneously. 0: Disable. (default) 1: Enable.					
3 - 2	INT_PIN[1:0]	These two bits control the output on the INT pin. X0: Open drain, active low. (default) 01: Push-pull, active low. 11: Push-pull, active high.					
1	GLB_IM	This bit is a global configuration interrupt mask bit. 0: The per-channel interrupt will be generated when the per-channel interrupt mask bit is '0' and the corresponding interrupt status bit is '1'. 1: Mask all the per-channel interrupts. None per-channel interrupts can be generated. (default)					
0	TMOV_IM	This bit controls whether the interrupt is generated when one second time is over. This one second timer is locked to MCLK. 0: Enable. 1: Mask. (default)					

MON - G.772 Monitor Configuration Register

Address: 0C0H

Type: Read / Write

Default Value: 00H

7	6	5	4	3	2	1	0
-	-	MON5	MON4	MON3	MON2	MON1	MON0

Bit	Name	Description
7 - 6	-	Reserved.
5 - 0	MON[5:0]	<p>These bits determine whether the G.772 Monitor is implemented. When the G.772 Monitor is implemented, these bits select one transmitter or receiver to be monitored by channel 0.</p> <p>000000: No transmitter or receiver is monitored. (default) 000001: The receiver of channel 1 is monitored. 000010: The receiver of channel 2 is monitored. 010100: The receiver of channel 20 is monitored. 010101: The receiver of channel 21 is monitored. 010110 ~ 011111: Reserved. 100000: No transmitter or receiver is monitored. 100001: The transmitter of channel 1 is monitored. 100010: The transmitter of channel 2 is monitored. 110100: The transmitter of channel 20 is monitored. 110101: The transmitter of channel 21 is monitored. 110110 ~ 111111: Reserved.</p>

GPIO - General Purpose I/O Pin Definition Register

Address: 100H Type: Read / Write Default Value: 0FH							
7	6	5	4	3	2	1	0
-	-	-	-	LEVEL1	LEVEL0	DIR1	DIR0
Bit	Name	Description					
7 - 4	-	Reserved.					
3	LEVEL1	When the GPIO1 pin is defined as output, this bit determines the output level on GPIO1 and can be read and written. 0: Output low level. 1: Output high level. (default) When the GPIO1 pin is defined as input, this bit indicates the input level on GPIO1 and can only be read. 0: Input low level. 1: Input high level. (default)					
2	LEVEL0	When the GPIO0 pin is defined as output, this bit determines the output level on GPIO0 and can be read and written. 0: Output low level. 1: Output high level. When the GPIO0 pin is defined as input, this bit indicates the input level on GPIO0 and can only be read. 0: Input low level. 1: Input high level. (default)					
1	DIR1	This bit determines whether the GPIO1 pin is used as output or input. 0: Output. 1: Input. (default)					
0	DIR0	This bit determines whether the GPIO0 pin is used as output or input. 0: Output. 1: Input. (default)					

CLKG - CLKE1 Generation Control Register

Address: 1C0H Type: Read / Write Default Value: 0FH							
7	6	5	4	3	2	1	0
-	-	-	-	-	-	-	-
Bit	Name	Description					
7 - 4	-	Reserved.					
3	CLKE1_EN	This bit controls whether the output on the CLKE1 pin is enabled. 0: The output is disabled. CLKE1 is in High-Z state. 1: The output is enabled. The frequency of CLKE1 is determined by the CLKE1 bit (b2, CLKG). (default)					
2	CLKE1	This bit is valid only when the CLKE1_EN bit (b3, CLKG) is '1'. This bit selects the clock frequency output on the CLKE1 pin. 0: 8 KHz. 1: 2.048 MHz. (default)					
1	-	Reserved.					
0	-	Reserved.					

REFCF - REFA/B Output Configuration Register

Address: 200H
 Type: Read / Write
 Default Value: 30H

7	6	5	4	3	2	1	0
-	JA_BYPAS	REFH	FS_BYPAS	FREE	FREQ2	FREQ1	FREQ0

Bit	Name	Description
7	-	Reserved.
6	JA_BYPAS	This bit is valid only when the clock source for REFA or REFB is the recovered clock of one of the 22 channels in the corresponding receiver. This bit determines whether the selected recovered clock passes through the RJA. 0: The selected recovered clock is derived from the output of RJA. (default) 1: The selected recovered clock does not pass through the RJA and is derived from the output of Rx Clock & Data Recovery.
5	REFH	This bit is valid only when the selected clock source is lost. This bit controls the output on REFA/REFB. For REFA, this bit, together with the FS_BYPAS bit (b4, REFCF) and the FREE bit (b3, REFCF), controls the output on REFA when the selected clock source is the recovered clock of one of the 22 channels; this bit is ignored when the selected clock source is CLKA. Refer to the related table in the description of the FREE bit (b3, REFCF). For REFB: 0: Output free running clock. The frequency is 2.048 MHz. 1: Output high level. (default)
4	FS_BYPAS	This bit determines whether the selected clock source for REFA passes through an internal Frequency Synthesizer. 0: The internal Frequency Synthesizer is enabled. 1: The internal Frequency Synthesizer is bypassed. (default)
3	FREE	This bit is valid only when the selected clock source for REFA passes the internal Frequency Synthesizer In normal operation: 0: Output the clock which is locked to the selected clock source and the frequency is programmed in the FREQ[2:0] bits (b2~0, REFCF). (default) 1: Output free running clock which is locked to MCLK and the frequency is programmed in the FREQ[2:0] bits (b2~0, REFCF). When the selected clock source is lost, this bit, together with the FS_BYPAS bit (b4, REFCF) and the REFH bit (b5, REFCF), controls the output on REFA:

Selected Clock Source	FS_BYPAS	FREE	REFH	Output On REFA
CLKA	0	0	(don't-care)	High level.
		1		Free running clock, whose frequency is programmed in the FREQ[2:0] bits (b2~0, REFCF).
	1	(don't-care)		High level.
Recovered clock of one of the 22 channels.	0	0	0	Free running clock, whose frequency is programmed in the FREQ[2:0] bits (b2~0, REFCF).
			1	High level.
	1	(don't-care)	0	Free running clock, whose frequency is programmed in the FREQ[2:0] bits (b2~0, REFCF).
			1	High level.

2 - 0	FREQ[2:0]	These bits are valid only when the Frequency Synthesizer on REFA is enabled. These bits determine the output clock frequency.		
		FREQ[2:0]	Output when FS_BYPAS=0, FREE=0 and the Frequency Synthesizer uses RCLKn or CLKA as reference clock	Output when FS_BYPAS=0 and FREE=1 (the Frequency Synthesizer is free running)
		0 0 0	2.048 MHz	-
		0 0 1	8 kHz	8 kHz
		0 1 0	64 kHz	64 kHz
		0 1 1	Reserved	-
		1 0 0	4.096 MHz	4.096 MHz
		1 0 1	8.192 MHz	8.192 MHz
		1 1 0	19.44 MHz	19.44 MHz
		1 1 1	32.768 MHz	32.768 MHz

REFA - REFA Clock Sources Configuration Register

Address: 240H Type: Read / Write Default Value: 41H							
7	6	5	4	3	2	1	0
-	REFA_EN	CKA_E1	REFA4	REFA3	REFA2	REFA1	REFA0
Bit	Name	Description					
7	-	Reserved.					
6	REFA_EN	This bit controls whether the output on the REFA pin is enabled. 0: The output is disabled. REFA is in High-Z state. 1: The output is enabled. (default)					
5	CKA_E1	This bit defines the input clock frequency on the CLKA pin. 0: Reserved. (default) 1: Input E1 clock.					
4 - 0	REFA[4:0]	These bits select the clock source for REFA. 00000: Recovered clock of channel 0. 00001: Recovered clock of channel 1. (default) 00010: Recovered clock of channel 2. 10100: Recovered clock of channel 20. 10101: Recovered clock of channel 21. 10110 ~ 11111: The input on CLKA.					

REFB - REFB Clock Sources Configuration Register

Address: 280H Type: Read / Write Default Value: 41H							
7	6	5	4	3	2	1	0
-	REFB_EN	CKB_E1	REFB4	REFB3	REFB2	REFB1	REFB0
Bit	Name	Description					
7	-	Reserved.					
6	REFB_EN	This bit controls whether the output on the REFB pin is enabled. 0: The output is disabled. REFB is in High-Z state. 1: The output is enabled. (default)					
5	CKB_E1	This bit defines the input clock frequency on the CLKB pin. 0: Reserved. (default) 1: Input E1 clock.					
4 - 0	REFB[4:0]	These bits select the clock source for REFB. 00000: Recovered clock of channel 0. 00001: Recovered clock of channel 1. (default) 00010: Recovered clock of channel 2. 10100: Recovered clock of channel 20. 10101: Recovered clock of channel 21. 10110 ~ 11111: The input on CLKB.					

INTCH1 - Interrupt Requisition Source Register 1

Address: 2C0H Type: Read / Write Default Value: 00H							
7	6	5	4	3	2	1	0
INT_CH8	INT_CH7	INT_CH6	INT_CH5	INT_CH4	INT_CH3	INT_CH2	INT_CH1
Bit	Name	Description					
7 - 0	INT_CH[8:1]	These bits indicate whether there is an interrupt generated in the corresponding channel. The INT_CH[8:1] bits correspond to channel 8 to 1 respectively. 0: No interrupt is generated or all the interrupts are cleared in the corresponding channel. (default) 1: At least one interrupt is generated in the corresponding channel.					

INTCH2 - Interrupt Requisition Source Register 2

Address: 300H Type: Read / Write Default Value: 00H							
7	6	5	4	3	2	1	0
INT_CH16	INT_CH15	INT_CH14	INT_CH13	INT_CH12	INT_CH11	INT_CH10	INT_CH9
Bit	Name	Description					
7 - 0	INT_CH[16:9]	These bits indicate whether there is an interrupt generated in the corresponding channel. The INT_CH[16:9] bits correspond to channel 16 to 9 respectively. 0: No interrupt is generated or all the interrupts are cleared in the corresponding channel. (default) 1: At least one interrupt is generated in the corresponding channel.					

INTCH3 - Interrupt Requisition Source Register 3

Address: 340H Type: Read / Write Default Value: 00H							
7	6	5	4	3	2	1	0
-	-	-	INT_CH21	INT_CH20	INT_CH19	INT_CH18	INT_CH17
Bit	Name	Description					
7 - 5	-	Reserved.					
4 - 0	INT_CH[21:17]	These bits indicate whether there is an interrupt generated in the corresponding channel. The INT_CH[21:17] bits correspond to channel 21 to 17 respectively. 0: No interrupt is generated or all the interrupts are cleared in the corresponding channel. (default) 1: At least one interrupt is generated in the corresponding channel.					

INTCH4 - Interrupt Requisition Source Register 4

Address: 380H Type: Read / Write Default Value: 00H							
7	6	5	4	3	2	1	0
INT_CH0	-	-	-	-	-	-	-
Bit	Name	Description					
7	INT_CH0	This bit indicates whether there is an interrupt generated in channel 0. 0: No interrupt is generated or all the interrupts are cleared in channel 0. (default) 1: At least one interrupt is generated in channel 0.					
6 - 0	-	Reserved.					

INTTM - One Second Timer Interrupt Status Register

Address: 3C0H Type: Read / Write Default Value: 00H							
7	6	5	4	3	2	1	0
-	-	-	-	-	-	-	TMOV_IS
Bit	Name	Description					
7 - 1	-	Reserved.					
0	TMOV_IS	This bit is valid only when the TMOV_IM bit (b0, GCF) is '0'. This bit indicates the interrupt status of one second time over. 0: No one second time over interrupt is generated; or a '1' is written to this bit. (default) 1: One second time over interrupt is generated and is reported by the INT pin.					

5.2.2 PER-CHANNEL REGISTER**CHCF - Channel Configuration Register**

Address: 001H, 041H, 081H, 0C1H, 101H, 141H, 181H, 1C1H, (CH1~CH8) 201H, 241H, 281H, 2C1H, 301H, 341H, 381H, 3C1H, (CH9~CH16) 401H, 441H, 481H, 4C1H, 501H, (CH17~CH21) 7C1H (CH0)							
Type: Read / Write Default Value: 00H							
7	6	5	4	3	2	1	0
-	-	-	-	-	-	CHRST	-
Bit	Name	Description					
7 - 2	-	Reserved.					
1	CHRST	Writing a '1' to this bit will initiate per-channel software reset. Once initiated, per-channel software reset completes in 1 μ s maximum. This bit is self cleared.					
0	-	Reserved.					

TJA - Transmit Jitter Attenuation Configuration Register

Address: 002H, 042H, 082H, 0C2H, 102H, 142H, 182H, 1C2H, (CH1~CH8)
 202H, 242H, 282H, 2C2H, 302H, 342H, 382H, 3C2H, (CH9~CH16)
 402H, 442H, 482H, 4C2H, 502H, (CH17~CH21)
 7C2H (CH0)

Type: Read / Write

Default Value: 00H

7	6	5	4	3	2	1	0
-	-	-	TJA_LIMIT	TJA_EN	TJA_DP1	TJA_DP0	TJA_BW

Bit	Name	Description
7 - 5	-	Reserved.
4	TJA_LIMIT	This bit determines whether the JA-Limit function is enabled in the TJA. 0: Disable. (default) 1: Enable. The speed of the TJA outgoing data will be adjusted automatically if the FIFO in the TJA is 2-bit close to its full or emptiness.
3	TJA_EN	This bit controls whether the TJA is enabled to use. 0: Disable. (default) 1: Enable.
2 - 1	TJA_DP[1:0]	These bits select the depth of the TJA FIFO. 00: 128-bit. (default) 01: 64-bit. 1X: 32-bit.
0	TJA_BW	This bit selects the Corner Frequency for the TJA. 0: 6.77 Hz. (default) 1: 0.87 Hz.

RJA - Receive Jitter Attenuation Configuration Register

Address: 003H, 043H, 083H, 0C3H, 103H, 143H, 183H, 1C3H, (CH1~CH8)
 203H, 243H, 283H, 2C3H, 303H, 343H, 383H, 3C3H, (CH9~CH16)
 403H, 443H, 483H, 4C3H, 503H, (CH17~CH21)
 7C3H (CH0)

Type: Read / Write

Default Value: 00H

Bit	Name	Description
7 - 5	-	Reserved.
4	RJA_LIMT	This bit determines whether the JA-Limit function is enabled in the RJA. 0: Disable. (default) 1: Enable. The speed of the RJA outgoing data will be adjusted automatically if the FIFO in the RJA is 2-bit close to its full or emptiness.
3	RJA_EN	This bit controls whether the RJA is enabled to use. 0: Disable. (default) 1: Enable.
2 - 1	RJA_DP[1:0]	These bits select the depth of the RJA FIFO. 00: 128-bit. (default) 01: 64-bit. 1X: 32-bit.
0	RJA_BW	This bit selects the Corner Frequency for the RJA. 0: 6.77 Hz. (default) 1: 0.87 Hz.

TCF0 - Transmit Configuration Register 0

Address: 004H, 044H, 084H, 0C4H, 104H, 144H, 184H, 1C4H, (CH1~CH8)
 204H, 244H, 284H, 2C4H, 304H, 344H, 384H, 3C4H, (CH9~CH16)
 404H, 444H, 484H, 4C4H, 504H, (CH17~CH21)
 7C4H (CH0)

Type: Read / Write

Default Value: 00H

Bit	Name	Description
7	-	Reserved.
6	OE	This bit determines the output of the Line Driver, i.e., the output on the TTIPn and TRINGn pins. 0: High-Z. (default) 1: Normal operation.
5	T_OFF	This bit determines whether the transmitter is powered down. 0: Normal operation. (default) 1: Power down.
4	THZ_OC	This bit determines the output of the Line Driver, i.e., the output on the TTIPn and TRINGn pins when TOC is detected. 0: The output current is limited to 100 mAp-p. (default) 1: The output current is limited to 100 mAp-p within the first 1 ms after the TOC is detected and then the output is in High-Z state when the TOC is detected for more than 1 ms.
3	T_SING	This bit determines the transmit line interface. 0: Transmit Differential line interface. Both TTIPn and TRINGn are used to transmit signal to the line side. (default) 1: Transmit Single Ended line interface. Only TTIPn is used to transmit signal. TRINGn should be left open.
2 - 0	T_TERM[2:0]	These bits select the impedance matching mode of the transmit path to match the cable impedance. 010: The 120 Ω internal impedance matching is selected for E1 120 Ω twisted pair cable (with transformer). 011: The 75 Ω internal impedance matching is selected for E1 75 Ω coaxial cable (with transformer). 110: The 120 Ω internal impedance matching is selected for E1 120 Ω twisted pair cable (transformer-less). 111: The external impedance matching is selected for E1 120 Ω twisted pair cable or E1 75 Ω coaxial cable (with transformer). Others: Reserved

TCF1 - Transmit Configuration Register 1

Address: 005H, 045H, 085H, 0C5H, 105H, 145H, 185H, 1C5H, (CH1~CH8)
 205H, 245H, 285H, 2C5H, 305H, 345H, 385H, 3C5H, (CH9~CH16)
 405H, 445H, 485H, 4C5H, 505H, (CH17~CH21)
 7C5H (CH0)

Type: Read / Write

Default Value: 01H

Bit	Name	Description
7 - 5	TMF_DEF[2:0]	These bits are valid only in Transmit Dual Rail RZ Format mode and Transmit Single Rail NRZ Format mode. They determine the indication on the TMFn pin. 000: PRBS/ARB indication when the PRBS/ARB detection is switched to the transmit path. Or reserved when the PRBS/ARB detection is switched to the receive path. (default) 001: SAIS indication. 010: TOC indication. 011: TLOS indication. 100: SEXZ indication. 101: SBPV indication in Transmit Dual Rail RZ Format mode. Reserved in Transmit Single Rail NRZ Format mode. 110: SEXZ + SBPV indication in Transmit Dual Rail RZ Format mode. Reserved in Transmit Single Rail NRZ Format mode. 111: SLOS indication in Transmit Dual Rail RZ Format mode. Reserved in Transmit Single Rail NRZ Format mode.
4	TCK_ES	This bit selects the active edge of the TCLKn pin. 0: Falling edge. (default) 1: Rising edge.
3	TD_INV	This bit determines the active level on the TDn, TDPn and TDNn pins. 0: Active high. (default) 1: Active low.
2	T_CODE	This bit selects the line code rule for the transmit path. 0: HDB3. (default) 1: AMI.
1 - 0	T_MD[1:0]	These bits determines the transmit system interface. 00: Transmit Single Rail NRZ Format system interface. The data is input on TDn in NRZ format and a 2.048 MHz clock is input on TCLKn. 01: Transmit Dual Rail NRZ Format system interface. The data is input on TDPn and TDNn in NRZ format and a 2.048 MHz clock is input on TCLKn. (default) 10: Transmit Dual Rail RZ Format system interface. The data is input on TDPn and TDNn in RZ format. 11: Reserved.

PULS - Transmit Pulse Configuration Register

Address: 006H, 046H, 086H, 0C6H, 106H, 146H, 186H, 1C6H, (CH1~CH8)
 206H, 246H, 286H, 2C6H, 306H, 346H, 386H, 3C6H, (CH9~CH16)
 406H, 446H, 486H, 4C6H, 506H, (CH17~CH21)
 7C6H (CH0)

Type: Read / Write

Default Value: 02H



Bit	Name	Description																														
7 - 4	-	Reserved.																														
3 - 0	PULS[3:0]	<p>These bits select one of the eight preset waveform templates for short haul application or enable user-programmable arbitrary waveform.</p> <table border="1" style="width: 100%; border-collapse: collapse; margin-top: 10px;"> <thead> <tr> <th style="width: 10%;">PULS[3:0]</th> <th style="width: 15%;">Operation Mode</th> <th style="width: 15%;">Transmit Clock</th> <th style="width: 25%;">Cable Impedance</th> <th style="width: 15%;">Cable Range</th> <th style="width: 20%;">Cable Loss</th> </tr> </thead> <tbody> <tr> <td>0000</td> <td>E1</td> <td>2.048 MHz</td> <td>E1 75 Ω differential interface, Internal Impedance matching mode</td> <td style="text-align: center;">-</td> <td>0 ~ 12 dB</td> </tr> <tr> <td>0001</td> <td>E1</td> <td>2.048 MHz</td> <td>Other E1 interfaces</td> <td style="text-align: center;">-</td> <td>0 ~ 12 dB</td> </tr> <tr> <td>1XXX</td> <td colspan="5" style="text-align: center;">User-programmable arbitrary waveform</td> </tr> <tr> <td>others</td> <td colspan="5" style="text-align: center;">Reserved.</td> </tr> </tbody> </table>	PULS[3:0]	Operation Mode	Transmit Clock	Cable Impedance	Cable Range	Cable Loss	0000	E1	2.048 MHz	E1 75 Ω differential interface, Internal Impedance matching mode	-	0 ~ 12 dB	0001	E1	2.048 MHz	Other E1 interfaces	-	0 ~ 12 dB	1XXX	User-programmable arbitrary waveform					others	Reserved.				
PULS[3:0]	Operation Mode	Transmit Clock	Cable Impedance	Cable Range	Cable Loss																											
0000	E1	2.048 MHz	E1 75 Ω differential interface, Internal Impedance matching mode	-	0 ~ 12 dB																											
0001	E1	2.048 MHz	Other E1 interfaces	-	0 ~ 12 dB																											
1XXX	User-programmable arbitrary waveform																															
others	Reserved.																															

SCAL - Amplitude Scaling Control Register

Address: 007H, 047H, 087H, 0C7H, 107H, 147H, 187H, 1C7H, (CH1~CH8)
 207H, 247H, 287H, 2C7H, 307H, 347H, 387H, 3C7H, (CH9~CH16)
 407H, 447H, 487H, 4C7H, 507H, (CH17~CH21)
 7C7H (CH0)

Type: Read / Write

Default Value: 36H

7	6	5	4	3	2	1	0
-	-	SCAL5	SCAL4	SCAL3	SCAL2	SCAL1	SCAL0
Bit	Name	Description					
7 - 6	-	Reserved.					
5 - 0	SCAL[5:0]	<p>These bits specify a scaling factor to be applied to the amplitude of the waveform to be transmitted. The standard value is '100001' for the waveform amplitude. If necessary, increasing or decreasing by '1' from the standard value will result in 3% scaling up or down against the waveform amplitude. The scale range is from +100% to -100%.</p> <p>Note: The default value for the SCAL[5:0] bits is '110110', which is different from the standard value '100001'.</p>					

AWG0 - Arbitrary Waveform Generation Control Register 0

Address: 008H, 048H, 088H, 0C8H, 108H, 148H, 188H, 1C8H, (CH1~CH8)
 208H, 248H, 288H, 2C8H, 308H, 348H, 388H, 3C8H, (CH9~CH16)
 408H, 448H, 488H, 4C8H, 508H, (CH17~CH21)
 7C8H (CH0)

Type: Read / Write

Default Value: 00H

7	6	5	4	3	2	1	0
-	DONE	RW	SAMP4	SAMP3	SAMP2	SAMP1	SAMP0
Bit	Name	Description					
7	-	Reserved.					
6	DONE	<p>This bit is valid only when the user-programmable arbitrary waveform is enabled (i.e., the PULS[3:0] bits (b3~0, PULS,...) are set to '1XXX'). This bit determines whether to enable the data writing/reading from RAM.</p> <p>0: Disable. (default) 1: Enable.</p>					
5	RW	<p>This bit is valid only when the user-programmable arbitrary waveform is enabled (i.e., the PULS[3:0] bits (b3~0, PULS,...) are set to '1XXX'). This bit determines read/write direction.</p> <p>0: Write data to RAM. (default) 1: Read data from RAM.</p>					
4 - 0	SAMP[4:0]	<p>These bits are valid only when the user-programmable arbitrary waveform is enabled (i.e., the PULS[3:0] bits (b3~0, PULS,...) are set to '1XXX'). These bits specify the RAM sample address.</p> <p>00000: The RAM sample address is 0. (default) 00001: The RAM sample address is 1. 00010: The RAM sample address is 2. 10001: The RAM sample address is 17. 10010: The RAM sample address is 18. 10011 ~ 11111: The RAM sample address is 19.</p>					

AWG1 - Arbitrary Waveform Generation Control Register 1

Address: 009H, 049H, 089H, 0C9H, 109H, 149H, 189H, 1C9H, (CH1~CH8)
 209H, 249H, 289H, 2C9H, 309H, 349H, 389H, 3C9H, (CH9~CH16)
 409H, 449H, 489H, 4C9H, 509H, (CH17~CH21)
 7C9H (CH0)

Type: Read / Write

Default Value: 00H



Bit	Name	Description
7	-	Reserved.
6 - 0	WDAT[6:0]	These bits are valid only when the user-programmable arbitrary waveform is enabled (i.e., the PULS[3:0] bits (b3~0, PULS,...) are set to '1XXX'). These bits contain the template sample data to be stored in RAM which address is specified by the SAMP[4:0] bits (b4~0, AWG0,...). They are not updated until new template sample data is written.

RCF0 - Receive Configuration Register 0

Address: 00AH, 04AH, 08AH, 0CAH, 10AH, 14AH, 18AH, 1CAH, (CH1~CH8)
 20AH, 24AH, 28AH, 2CAH, 30AH, 34AH, 38AH, 3CAH, (CH9~CH16)
 40AH, 44AH, 48AH, 4CAH, 50AH, (CH17~CH21)
 7CAH (CH0)

Type: Read / Write

Default Value: 47H

7	6	5	4	3	2	1	0
RCKH	RHZ	R_OFF	R120IN	R_SING	R_TERM2	R_TERM1	R_TERM0
Bit	Name	Description					
7	RCKH	This bit determines the output on RCLKn when LLOS is detected. This bit is valid only when LLOS is detected and the AIS and pattern generation is disabled in the receive path. 0: XCLK. (default) 1: High level.					
6	RHZ	This bit determines the output of all receive system interfaced pins (including RDn, RDPn, RDNn, RMFn and RCLKn) when the corresponding receiver is powered down. 0: Low level. 1: High-Z. (default)					
5	R_OFF	This bit determines whether the receiver is powered down. 0: Normal operation. (default) 1: Power down.					
4	R120IN	This bit is valid only when the receive line interface is in Receive Differential mode and per-channel internal impedance matching configuration is enabled. This bit selects the internal impedance matching mode. 0: Partially Internal Impedance Matching mode. An internal programmable resistor (IM) and a value-fixed external resistor (Rr) are used. (default) 1: Fully Internal Impedance Matching mode. Only an internal programmable resistor (IM) is used.					
3	R_SING	This bit determines the receive line interface. 0: Receive Differential line interface. Both RTIPn and RRINGn are used to receive signal from the line side. (default) 1: Receive Single Ended line interface. Only RTIPn is used to receive signal. RRINGn should be left open.					
2 - 0	R_TERM[2:0]	These bits are valid only when impedance matching is configured on a per-channel basis. These bits select the impedance matching mode of the receive path to match the cable impedance. In Receive Differential mode: 010: The 120 Ω internal impedance matching is selected for E1 120 Ω twisted pair cable. 011: The 75 Ω internal impedance matching is selected for E1 75 Ω coaxial cable. 1XX: External impedance matching is selected for E1 120 Ω twisted pair cable and E1 75 Ω coaxial cable. In Receive Single Ended mode, only External Impedance Matching is supported and the setting of these bits is a don't-care. (default) Others: Reserved.					

RCF1 - Receive Configuration Register 1

Address: 00BH, 04BH, 08BH, 0CBH, 10BH, 14BH, 18BH, 1CBH, (CH1~CH8)
 20BH, 24BH, 28BH, 2CBH, 30BH, 34BH, 38BH, 3CBH, (CH9~CH16)
 40BH, 44BH, 48BH, 4CBH, 50BH, (CH17~CH21)
 7CBH (CH0)

Type: Read / Write

Default Value: 01H

7	6	5	4	3	2	1	0
RMF_DEF2	RMF_DEF1	RMF_DEF0	RCK_ES	RD_INV	R_CODE	R_MD1	R_MD0
Bit	Name	Description					
7 - 5	RMF_DEF[2:0]	These bits are valid only in Receive Single Rail NRZ Format mode and Receive Dual Rail Sliced mode. They determine the output on the RMFn pin. 000: PRBS/ARB indication when the PRBS/ARB detection is switched to the receive path. Or reserved when the PRBS/ARB detection is switched to the transmit path. (default) 001: LAIS indication. 010: XOR data of positive and negative sliced data. 011: Recovered clock (RCLK). 100: LEXZ indication. 101: LBPV indication. 110: LEXZ + LBPV indication. 111: LLOS indication.					
4	RCK_ES	This bit selects the active edge of the RCLKn pin. 0: Rising edge. (default) 1: Falling edge.					
3	RD_INV	This bit determines the active level on the RDn, RDPn and RDNn pins. 0: Active high. (default) 1: Active low.					
2	R_CODE	This bit selects the line code rule for the receive path. 0: HDB3. (default) 1: AMI.					
1 - 0	R_MD[1:0]	These bits determines the receive system interface. 00: Receive Single Rail NRZ Format system interface. The data is output on RDn in NRZ format and a 2.048 MHz recovered clock is output on RCLKn. 01: Receive Dual Rail NRZ Format system interface. The data is output on RDPn and RDNn in NRZ format and a 2.048 MHz recovered clock is output on RCLKn. (default) 10: Receive Dual Rail RZ Format system interface. The data is output on RDPn and RDNn in RZ format and a 2.048 MHz recovered clock is output on RCLKn. 11: Receive Dual Rail Sliced system interface. The data is output on RDPn and RDNn in RZ format directly after passing through the Slicer.					

RCF2 - Receive Configuration Register 2

Address: 00CH, 04CH, 08CH, 0CCH, 10CH, 14CH, 18CH, 1CCH, (CH1~CH8)
 20CH, 24CH, 28CH, 2CCH, 30CH, 34CH, 38CH, 3CCH, (CH9~CH16)
 40CH, 44CH, 48CH, 4CCH, 50CH, (CH17~CH21)
 7CCH (CH0)
 Type: Read / Write
 Default Value: 00H



Bit	Name	Description
7 - 2	-	Reserved.
1 - 0	MG[1:0]	These bits select the Monitor Gain. 00: 0 dB. (default) 01: 20 dB. 10: 26 dB. 11: 32 dB.

LOS - LOS Configuration Register

Address: 00DH, 04DH, 08DH, 0CDH, 10DH, 14DH, 18DH, 1CDH, (CH1~CH8)
 20DH, 24DH, 28DH, 2CDH, 30DH, 34DH, 38DH, 3CDH, (CH9~CH16)
 40DH, 44DH, 48DH, 4CDH, 50DH, (CH17~CH21)
 7CDH (CH0)

Type: Read / Write

Default Value: 15H

7	6	5	4	3	2	1	0
LAC	ALOS2	ALOS1	ALOS0	TALOS1	TALOS0	TDLOS1	TDLOS0

Bit	Name	Description																																																												
7	LAC	This bit selects the LLOS, SLOS and AIS criteria. 0: G.775. (default) 1: ETSI 300233 & I.431.																																																												
6 - 4	ALOS[2:0]	<p>These bits select the amplitude threshold (Q). When the amplitude of the data is less than Q Vpp for N consecutive pulse intervals, LLOS is declared. The consecutive pulse intervals (N) are determined by the LAC bit (b7, LOS,...). The ALOS[2:0] settings for Normal Receive mode and Line Monitor mode are different. Refer to below tables.</p> <p>ALOS[2:0] Setting in Normal Receive Mode</p> <table border="1"> <thead> <tr> <th>ALOS[2:0]</th> <th>Q (Vpp)</th> <th>vs. 6.0 Vpp (dB)</th> <th>vs. 4.74 Vpp (dB)</th> </tr> </thead> <tbody> <tr> <td>000</td> <td>0.5</td> <td>21.58</td> <td>19.54</td> </tr> <tr> <td>001 (default)</td> <td>0.7</td> <td>18.66</td> <td>16.61</td> </tr> <tr> <td>010</td> <td>0.9</td> <td>16.48</td> <td>14.43</td> </tr> <tr> <td>011</td> <td>1.2</td> <td>13.98</td> <td>11.93</td> </tr> <tr> <td>100</td> <td>1.4</td> <td>12.64</td> <td>10.59</td> </tr> <tr> <td>101</td> <td>1.6</td> <td>11.48</td> <td>9.43</td> </tr> <tr> <td>110</td> <td>1.8</td> <td>10.46</td> <td>8.41</td> </tr> <tr> <td>111</td> <td>2.0</td> <td>9.54</td> <td>7.49</td> </tr> </tbody> </table> <p>ALOS[2:0] Setting in Line Monitor Mode</p> <table border="1"> <thead> <tr> <th>ALOS[2:0]</th> <th>Q (Vpp)</th> <th>vs. 6.0 Vpp (dB)</th> <th>vs. 4.74 Vpp (dB)</th> </tr> </thead> <tbody> <tr> <td>000</td> <td>1.0</td> <td>15.56</td> <td>13.52</td> </tr> <tr> <td>001 (default)</td> <td>1.4</td> <td>12.64</td> <td>10.59</td> </tr> <tr> <td>010</td> <td>1.8</td> <td>10.46</td> <td>8.41</td> </tr> <tr> <td>011</td> <td>2.2</td> <td>8.71</td> <td>6.67</td> </tr> <tr> <td>1xx</td> <td colspan="3">reserved.</td> </tr> </tbody> </table>	ALOS[2:0]	Q (Vpp)	vs. 6.0 Vpp (dB)	vs. 4.74 Vpp (dB)	000	0.5	21.58	19.54	001 (default)	0.7	18.66	16.61	010	0.9	16.48	14.43	011	1.2	13.98	11.93	100	1.4	12.64	10.59	101	1.6	11.48	9.43	110	1.8	10.46	8.41	111	2.0	9.54	7.49	ALOS[2:0]	Q (Vpp)	vs. 6.0 Vpp (dB)	vs. 4.74 Vpp (dB)	000	1.0	15.56	13.52	001 (default)	1.4	12.64	10.59	010	1.8	10.46	8.41	011	2.2	8.71	6.67	1xx	reserved.		
ALOS[2:0]	Q (Vpp)	vs. 6.0 Vpp (dB)	vs. 4.74 Vpp (dB)																																																											
000	0.5	21.58	19.54																																																											
001 (default)	0.7	18.66	16.61																																																											
010	0.9	16.48	14.43																																																											
011	1.2	13.98	11.93																																																											
100	1.4	12.64	10.59																																																											
101	1.6	11.48	9.43																																																											
110	1.8	10.46	8.41																																																											
111	2.0	9.54	7.49																																																											
ALOS[2:0]	Q (Vpp)	vs. 6.0 Vpp (dB)	vs. 4.74 Vpp (dB)																																																											
000	1.0	15.56	13.52																																																											
001 (default)	1.4	12.64	10.59																																																											
010	1.8	10.46	8.41																																																											
011	2.2	8.71	6.67																																																											
1xx	reserved.																																																													
3 - 2	TALOS[1:0]	<p>These bits select the amplitude threshold. When the amplitude of the data is less than the threshold for a certain period, TLOS is declared. The period is determined by the TDLOS bits (b1~0, LOS,...). When the amplitude of a pulse is above the threshold, TLOS is cleared.</p> <p>For Differential line interface: 00: 1.2 Vp. 01: 0.9 Vp. (default) 10: 0.6 Vp. 11: 0.4 Vp.</p> <p>For Single Ended line interface: 00: 0.61 Vp. 01: 0.48 Vp. (default) 10: 0.32 Vp. 11: 0.24 Vp.</p>																																																												

1 - 0	TDLOS[1:0]	These bits select the period. When the amplitude of the data is less than a certain voltage for the period, TLOS is declared. The voltage is determined by the TALOS bits (b3~2, LOS,...). 00: 16-pulse. 01: 32-pulse. (default) 1X: 64-pulse.
-------	------------	---

ERR - Error Detection & Insertion Control Register

Address: 00EH, 04EH, 08EH, 0CEH, 10EH, 14EH, 18EH, 1CEH, (CH1~CH8)
20EH, 24EH, 28EH, 2CEH, 30EH, 34EH, 38EH, 3CEH, (CH9~CH16)
40EH, 44EH, 48EH, 4CEH, 50EH, (CH17~CH21)
7CEH (CH0)

Type: Read / Write

Default Value: 00H

7	6	5	4	3	2	1	0
EXZ_DEF	BPV_INS	ERR_INS	CNT_SEL2	CNT_SEL1	CNT_SEL0	CNT_MD	CNT_STOP

Bit	Name	Description
7	EXZ_DEF	This bit selects the EXZ definition standard. 0: ANSI. (default) 1: FCC.
6	BPV_INS	This bit controls whether to insert a bipolar violation (BPV) to the transmit path. Writing '1' to this bit will insert a BPV on the next available mark in the data stream to be transmitted. This bit is cleared once the BPV insertion is completed.
5	ERR_INS	This bit controls whether to insert a single bit error to the generated PRBS/ARB pattern. A transition from '0' to '1' on this bit will insert a single bit error to the generated PRBS/ARB pattern. This bit is cleared once the single bit error insertion is completed.
4 - 2	CNT_SEL[2:0]	These bits select what kind of error to be counted by the internal Error Counter. 000: Disable. (default) 001: LBPV. 010: LEXZ. 011: LBPV + LEXZ. 100: SBPV. 101: SEXZ. 110: SBPV + SEXZ. 111: PRBS/ARB error.
1	CNT_MD	This bit determines whether the ERRCH & ERRCL registers are updated automatically or manually. 0: Manually by setting the CNT_STOP bit (b0, ERR,...). (default) 1: Every-one second automatically.
0	CNT_STOP	This bit is valid only when the CNT_MD bit (b1, ERR,...) is '0'. A transition from '0' to '1' on this bit updates the ERRCH & ERRCL registers. This bit must be cleared before the next round.

AISG - AIS Generation Control Register

Address: 00FH, 04FH, 08FH, 0CFH, 10FH, 14FH, 18FH, 1CFH, (CH1~CH8)
 20FH, 24FH, 28FH, 2CFH, 30FH, 34FH, 38FH, 3CFH, (CH9~CH16)
 40FH, 44FH, 48FH, 4CFH, 50FH, (CH17~CH21)
 7CFH (CH0)

Type: Read / Write

Default Value: 00H

7	6	5	4	3	2	1	0
-	-	-	-	ASAIS_SLOS	ASAIS_LLOS	ALAIS_SLOS	ALAIS_LLOS

Bit	Name	Description
7 - 4	-	Reserved.
3	ASAIS_SLOS	This bit controls the AIS generation in the receive path once SLOS is detected. 0: Disable. (default) 1: Enable.
2	ASAIS_LLOS	This bit controls the AIS generation in the receive path once LLOS is detected. 0: Disable. (default) 1: Enable.
1	ALAIS_SLOS	This bit controls the AIS generation in the transmit path once SLOS is detected. 0: Disable. (default) 1: Enable.
0	ALAIS_LLOS	This bit controls the AIS generation in the transmit path once LLOS is detected. 0: Disable. (default) 1: Enable.

PG - Pattern Generation Control Register

Address: 010H, 050H, 090H, 0D0H, 110H, 150H, 190H, 1D0H, (CH1~CH8)
 210H, 250H, 290H, 2D0H, 310H, 350H, 390H, 3D0H, (CH9~CH16)
 410H, 450H, 490H, 4D0H, 510H, (CH17~CH21)
 7D0H (CH0)

Type: Read / Write

Default Value: 00H

Bit	Name	Description
7	-	Reserved.
6	PG_CK	This bit selects the reference clock when the pattern (including PRBS, ARB & IB) is generated. When the pattern is generated in the receive path: 0: XCLK. (default) 1: Recovered clock from the received signal. When the pattern is generated in the transmit path: 0: XCLK. (default) 1: Transmit clock, i.e., the clock input on TCLKn (in Transmit Single Rail NRZ Format mode and in Transmit Dual Rail NRZ Format mode) or the clock recovered from the data input on TDPn and TDNn (in Transmit Dual Rail RZ Format mode)
5 - 4	PG_EN[1:0]	These bits select the pattern to be generated. 00: Disable. (default) 01: PRBS. 10: ARB. 11: IB.
3	PG_POS	This bit selects the pattern (including PRBS, ARB & IB) generation direction. 0: Transmit path. (default) 1: Receive path.
2	PAG_INV	This bit controls whether to invert the generated PRBS/ARB pattern. 0: Normal. (default) 1: Invert.
1 - 0	PRBG_SEL[1:0]	These bits are valid only when the PRBS pattern is generated. They select the PRBS pattern. 00: $2^{20} - 1$ QRSS. (default) 01: $2^{15} - 1$ PRBS. 1X: $2^{11} - 1$ PRBS.

PD - Pattern Detection Control Register

Address: 011H, 051H, 091H, 0D1H, 111H, 151H, 191H, 1D1H, (CH1~CH8)
 211H, 251H, 291H, 2D1H, 311H, 351H, 391H, 3D1H, (CH9~CH16)
 411H, 451H, 491H, 4D11H, 511H, (CH17~CH21)
 7D1H (CH0)

Type: Read / Write

Default Value: 03H

7	6	5	4	3	2	1	0
-	-	-	-	PD_POS	PAD_INV	PAD_SEL1	PAD_SEL0

Bit	Name	Description
7 - 4	-	Reserved.
3	PD_POS	This bit selects the pattern (including PRBS, ARB & IB) detection direction. 0: Receive path. (default) 1: Transmit path.
2	PAD_INV	This bit controls whether to invert the data before PRBS/ARB detection. 0: Normal. (default) 1: Invert.
1 - 0	PAD_SEL[1:0]	These bits select the desired PRBS/ARB pattern to be detected. 00: 2 ²⁰ - 1 QRSS. 01: 2 ¹⁵ - 1 PRBS. 10: 2 ¹¹ - 1 PRBS. 11: ARB. (default)

ARBL - Arbitrary Pattern Generation / Detection Low-Byte Register

Address: 012H, 052H, 092H, 0D2H, 112H, 152H, 192H, 1D2H, (CH1~CH8)
 212H, 252H, 292H, 2D2H, 312H, 352H, 392H, 3D2H, (CH9~CH16)
 412H, 452H, 492H, 4D2H, 512H, (CH17~CH21)
 7D2H (CH0)

Type: Read / Write

Default Value: 55H

7	6	5	4	3	2	1	0
ARB7	ARB6	ARB5	ARB4	ARB3	ARB2	ARB1	ARB0
Bit	Name	Description					
7 - 0	ARB[7:0]	These bits, together with the ARB[23:8] bits, define the ARB pattern to be generated or detected. The ARB23 bit is the first bit to be generated or detected and the ARB0 bit is the last bit to be generated or detected.					

ARBM - Arbitrary Pattern Generation / Detection Middle-Byte Register

Address: 013H, 053H, 093H, 0D3H, 113H, 153H, 193H, 1D3H, (CH1~CH8)
 213H, 253H, 293H, 2D3H, 313H, 353H, 393H, 3D3H, (CH9~CH16)
 413H, 453H, 493H, 4D3H, 513H, (CH17~CH21)
 7D3H (CH0)

Type: Read / Write

Default Value: 55H

7	6	5	4	3	2	1	0
ARB15	ARB14	ARB13	ARB12	ARB11	ARB10	ARB9	ARB8
Bit	Name	Description					
7 - 0	ARB[15:8]	(Refer to the description of the ARBL register.)					

ARBH - Arbitrary Pattern Generation / Detection High-Byte Register

Address: 014H, 054H, 094H, 0D4H, 114H, 154H, 194H, 1D4H, (CH1~CH8)
 214H, 254H, 294H, 2D4H, 314H, 354H, 394H, 3D4H, (CH9~CH16)
 414H, 454H, 494H, 4D4H, 514H, (CH17~CH21)
 7D4H (CH0)

Type: Read / Write

Default Value: 55H

7	6	5	4	3	2	1	0
ARB23	ARB22	ARB21	ARB20	ARB19	ARB18	ARB17	ARB16
Bit	Name	Description					
7 - 0	ARB[23:16]	(Refer to the description of the ARBL register.)					

IBL - Inband Loopback Control Register

Address: 015H, 055H, 095H, 0D5H, 115H, 155H, 195H, 1D5H, (CH1~CH8)
 215H, 255H, 295H, 2D5H, 315H, 355H, 395H, 3D5H, (CH9~CH16)
 415H, 455H, 495H, 4D5H, 515H, (CH17~CH21)
 7D5H (CH0)

Type: Read / Write

Default Value: 01H

Bit	Name	Description
7 - 6	-	Reserved.
5 - 4	IBGL[1:0]	These bits define the length of the valid IB generation code programmed in the IBG[7:0] bits (b7~0, IBG,...). 00: 5-bit long in the IBG[4:0] bits (b4~0, IBG,...). (default) 01: 6-bit long in the IBG[5:0] bits (b5~0, IBG,...). 10: 7-bit long in the IBG[6:0] bits (b6~0, IBG,...). 11: 8-bit long in the IBG[7:0] bits (b7~0, IBG,...).
3 - 2	IBAL[1:0]	These bits define the length of the valid target activate IB detection code programmed in the IBA[7:0] bits (b7~0, IBDA,...). 00: 5-bit long in the IBA[4:0] bits (b4~0, IBDA,...). (default) 01: 6-bit long in the IBA[5:0] bits (b5~0, IBDA,...). 10: 7-bit long in the IBA[6:0] bits (b6~0, IBDA,...). 11: 8-bit long in the IBA[7:0] bits (b7~0, IBDA,...).
1 - 0	IBDL[1:0]	These bits define the length of the valid target deactivate IB detection code programmed in the IBD[7:0] bits (b7~0, IBDD,...). 00: 5-bit long in the IBD[4:0] bits (b4~0, IBDD,...). 01: 6-bit long in the IBD[5:0] bits (b5~0, IBDD,...). (default) 10: 7-bit long in the IBD[6:0] bits (b6~0, IBDD,...). 11: 8-bit long in the IBD[7:0] bits (b7~0, IBDD,...).

IBG - Inband Loopback Generation Code Definition Register

Address: 016H, 056H, 096H, 0D6H, 116H, 156H, 196H, 1D6H, (CH1~CH8)
 216H, 256H, 296H, 2D6H, 316H, 356H, 396H, 3D6H, (CH9~CH16)
 416H, 456H, 496H, 4D6H, 516H, (CH17~CH21)
 7D6H (CH0)

Type: Read / Write

Default Value: 01H

Bit	Name	Description
7 - 0	IBG[7:0]	The IBG[X:0] bits define the content of the IB generation code. The 'X' is determined by the IBGL[1:0] bits (b5~4, IBL,...). The IBG0 bit is the last bit to be generated. The code is generated repeatedly until the IB generation is stopped.

IBDA - Inband Loopback Detection Target Activate Code Definition Register

Address: 017H, 057H, 097H, 0D7H, 117H, 157H, 197H, 1D7H, (CH1~CH8)
 217H, 257H, 297H, 2D7H, 317H, 357H, 397H, 3D7H, (CH9~CH16)
 417H, 457H, 497H, 4D7H, 517H, (CH17~CH21)
 7D7H (CH0)

Type: Read / Write

Default Value: 01H

7	6	5	4	3	2	1	0
IBA7	IBA6	IBA5	IBA4	IBA3	IBA2	IBA1	IBA0

Bit	Name	Description
7 - 0	IBA[7:0]	The IBA[X:0] bits define the content of the target activate IB detection code. The 'X' is determined by the IBAL[1:0] bits (b3~2, IBL,...). The IBA0 bit is the last bit to be detected.

IBDD - Inband Loopback Detection Target Deactivate Code Definition Register

Address: 018H, 058H, 098H, 0D8H, 118H, 158H, 198H, 1D8H, (CH1~CH8)
 218H, 258H, 298H, 2D8H, 318H, 358H, 398H, 3D8H, (CH9~CH16)
 418H, 458H, 498H, 4D8H, 518H, (CH17~CH21)
 7D8H (CH0)

Type: Read / Write

Default Value: 09H

7	6	5	4	3	2	1	0
IBD7	IBD6	IBD5	IBD4	IBD3	IBD2	IBD1	IBD0

Bit	Name	Description
7 - 0	IBD[7:0]	The IBD[X:0] bits define the content of the target deactivate IB detection code. The 'X' is determined by the IBDL[1:0] bits (b1~0, IBL,...). The IBD0 bit is the last bit to be detected.

LOOP - Loopback Control Register

Address: 019H, 059H, 099H, 0D9H, 119H, 159H, 199H, 1D9H, (CH1~CH8)
 219H, 259H, 299H, 2D9H, 319H, 359H, 399H, 3D9H, (CH9~CH16)
 419H, 459H, 499H, 4D9H, 519H, (CH17~CH21)
 7D9H (CH0)

Type: Read / Write

Default Value: 00H

7	6	5	4	3	2	1	0
-	-	-	-	AUTOLP	DLP	RLP	ALP

Bit	Name	Description
7 - 4	-	Reserved.
3	AUTOLP	This bit determines whether automatic Digital/Remote Loopback is enabled. 0: Automatic Digital/Remote Loopback is disabled. (default) 1: Automatic Digital/Remote Loopback is enabled. The corresponding channel will enter Digital/Remote Loopback when the activate IB code is detected in the transmit/receive path for more than 5.1 sec.; and will return from Digital/Remote Loopback when the deactivate IB code is detected in the transmit/receive path for more than 5.1 sec.
2	DLP	This bit controls whether Digital Loopback is enabled. 0: Disable. (default) 1: Enable.
1	RLP	This bit controls whether Remote Loopback is enabled. 0: Disable. (default) 1: Enable.
0	ALP	This bit controls whether Analog Loopback is enabled. 0: Disable. (default) 1: Enable.

INTES - Interrupt Trigger Edges Select Register

Address: 01AH, 05AH, 09AH, 0DAH, 11AH, 15AH, 19AH, 1DAH, (CH1~CH8)
 21AH, 25AH, 29AH, 2DAH, 31AH, 35AH, 39AH, 3DAH, (CH9~CH16)
 41AH, 45AH, 49AH, 4DAH, 51AH, (CH17~CH21)
 7DAH (CH0)

Type: Read / Write

Default Value: 00H

7	6	5	4	3	2	1	0
-	AIS_IES	PA_IES	TOC_IES	TCKLOS_IES	TLOS_IES	LOS_IES	IB_IES
Bit	Name	Description					
7	-	Reserved.					
6	AIS_IES	This bit selects the transition edge of the LAIS_S bit (b6, STAT1,...) and the SAIS_S bit (b7, STAT1,...). 0: A transition from '0' to '1' on the LAIS_S bit (b6, STAT1,...) / the SAIS_S bit (b7, STAT1,...) will set the LAIS_IS bit (b6, INTS1,...) / the SAIS_IS bit (b7, INTS1,...) to '1' respectively. (default) 1: Any transition from '0' to '1' or from '1' to '0' on the LAIS_S bit (b6, STAT1,...) / the SAIS_S bit (b7, STAT1,...) will set the LAIS_IS bit (b6, INTS1,...) / the SAIS_IS bit (b7, INTS1,...) to '1' respectively.					
5	PA_IES	This bit selects the transition edge of the PA_S bit (b5, STAT1,...). 0: A transition from '0' to '1' on the PA_S bit (b5, STAT1,...) will set the PA_IS bit (b5, INTS1,...) to '1'. (default) 1: Any transition from '0' to '1' or from '1' to '0' on the PA_S bit (b5, STAT1,...) will set the PA_IS bit (b5, INTS1,...) to '1'.					
4	TOC_IES	This bit selects the transition edge of the TOC_S bit (b4, STAT0,...). 0: A transition from '0' to '1' on the TOC_S bit (b4, STAT0,...) will set the TOC_IS bit (b4, INTS0,...) to '1'. (default) 1: Any transition from '0' to '1' or from '1' to '0' on the TOC_S bit (b4, STAT0,...) will set the TOC_IS bit (b4, INTS0,...) to '1'.					
3	TCKLOS_IES	This bit selects the transition edge of the TCKLOS_S bit (b3, STAT0,...). 0: A transition from '0' to '1' on the TCKLOS_S bit (b3, STAT0,...) will set the TCKLOS_IS bit (b3, INTS0,...) to '1'. (default) 1: Any transition from '0' to '1' or from '1' to '0' on the TCKLOS_S bit (b3, STAT0,...) will set the TCKLOS_IS bit (b3, INTS0,...) to '1'.					
2	TLOS_IES	This bit selects the transition edge of the TLOS_S bit (b2, STAT0,...). 0: A transition from '0' to '1' on the TLOS_S bit (b2, STAT0,...) will set the TLOS_IS bit (b2, INTS0,...) to '1'. (default) 1: Any transition from '0' to '1' or from '1' to '0' on the TLOS_S bit (b2, STAT0,...) will set the TLOS_IS bit (b2, INTS0,...) to '1'.					
1	LOS_IES	This bit selects the transition edge of the LLOS_S bit (b0, STAT0,...) and the SLOS_S bit (b1, STAT0,...). 0: A transition from '0' to '1' on the LLOS_S bit (b0, STAT0,...) / the SLOS_S bit (b1, STAT0,...) will set the LLOS_IS bit (b0, INTS0,...) / the SLOS_IS bit (b1, INTS0,...) to '1' respectively. (default) 1: Any transition from '0' to '1' or from '1' to '0' on the LLOS_S bit (b0, STAT0,...) / the SLOS_S bit (b1, STAT0,...) will set the LLOS_IS bit (b0, INTS0,...) / the SLOS_IS bit (b1, INTS0,...) to '1' respectively.					
0	IB_IES	This bit selects the transition edge of the IBA_S bit (b1, STAT1,...) and the IBD_S bit (b0, STAT1,...). 0: A transition from '0' to '1' on the IBA_S bit (b1, STAT1,...) / the IBD_S bit (b0, STAT1,...) will set the IBA_IS bit (b1, INTS1,...) / the IBD_IS bit (b0, INTS1,...) to '1' respectively. (default) 1: Any transition from '0' to '1' or from '1' to '0' on the IBA_S bit (b1, STAT1,...) / the IBD_S bit (b0, STAT1,...) will set the IBA_IS bit (b1, INTS1,...) / the IBD_IS bit (b0, INTS1,...) to '1' respectively.					

INTM0 - Interrupt Mask Register 0

Address: 01BH, 05BH, 09BH, 0DBH, 11BH, 15BH, 19BH, 1DBH, (CH1~CH8)
 21BH, 25BH, 29BH, 2DBH, 31BH, 35BH, 39BH, 3DBH, (CH9~CH16)
 41BH, 45BH, 49BH, 4DBH, 51BH, (CH17~CH21)
 7DBH (CH0)

Type: Read / Write

Default Value: FFH

7	6	5	4	3	2	1	0
DAC_IM	TJA_IM	RJA_IM	TOC_IM	TCKLOS_IM	TLOS_IM	SLOS_IM	LLOS_IM

Bit	Name	Description
7	DAC_IM	This bit is the waveform amplitude overflow interrupt mask. 0: Interrupt is enabled. 1: Interrupt is masked. (default)
6	TJA_IM	This bit is the TJA FIFO overflow and underflow interrupt mask. 0: Interrupt is enabled. 1: Interrupt is masked. (default)
5	RJA_IM	This bit is the RJA FIFO overflow and underflow interrupt mask. 0: Interrupt is enabled. 1: Interrupt is masked. (default)
4	TOC_IM	This bit is the Line Driver TOC interrupt mask. 0: Interrupt is enabled. 1: Interrupt is masked. (default)
3	TCKLOS_IM	This bit is the TCLKn missing interrupt mask. 0: Interrupt is enabled. 1: Interrupt is masked. (default)
2	TLOS_IM	This bit is the TLOS interrupt mask. 0: Interrupt is enabled. 1: Interrupt is masked. (default)
1	SLOS_IM	This bit is the SLOS interrupt mask. 0: Interrupt is enabled. 1: Interrupt is masked. (default)
0	LLOS_IM	This bit is the LLOS interrupt mask. 0: Interrupt is enabled. 1: Interrupt is masked. (default)

INTM1 - Interrupt Mask Register 1

Address: 01CH, 05CH, 09CH, 0DCH, 11CH, 15CH, 19CH, 1DCH, (CH1~CH8)
 21CH, 25CH, 29CH, 2DCH, 31CH, 35CH, 39CH, 3DCH, (CH9~CH16)
 41CH, 45CH, 49CH, 4DCH, 51CH, (CH17~CH21)
 7DCH (CH0)

Type: Read / Write

Default Value: EFH

7	6	5	4	3	2	1	0
SAIS_IM	LAIS_IM	PA_IM	-	-	-	IBA_IM	IBD_IM

Bit	Name	Description
7	SAIS_IM	This bit is the SAIS interrupt mask. 0: Interrupt is enabled. 1: Interrupt is masked. (default)
6	LAIS_IM	This bit is the LAIS interrupt mask. 0: Interrupt is enabled. 1: Interrupt is masked. (default)
5	PA_IM	This bit is the PRBS/ARB pattern synchronization interrupt mask. 0: Interrupt is enabled. 1: Interrupt is masked. (default)
4 - 2	-	Reserved.
1	IBA_IM	This bit is the activate IB code interrupt mask. 0: Interrupt is enabled. 1: Interrupt is masked. (default)
0	IBD_IM	This bit is the deactivate IB code interrupt mask. 0: Interrupt is enabled. 1: Interrupt is masked. (default)

INTM2 - Interrupt Mask Register 2

Address: 01DH, 05DH, 09DH, 0DDH, 11DH, 15DH, 19DH, 1DDH, (CH1~CH8)
 21DH, 25DH, 29DH, 2DDH, 31DH, 35DH, 39DH, 3DDH, (CH9~CH16)
 41DH, 45DH, 49DH, 4DDH, 51DH, (CH17~CH21)
 7DDH (CH0)

Type: Read / Write

Default Value: 3FH

7	6	5	4	3	2	1	0
-	-	SBPV_IM	LBPV_IM	SEXZ_IM	LEXZ_IM	ERR_IM	CNTOV_IM

Bit	Name	Description
7 - 6	-	Reserved.
5	SBPV_IM	This bit is the SBPV interrupt mask. 0: Interrupt is enabled. 1: Interrupt is masked. (default)
4	LBPV_IM	This bit is the LBPV interrupt mask. 0: Interrupt is enabled. 1: Interrupt is masked. (default)
3	SEXZ_IM	This bit is the SEXZ interrupt mask. 0: Interrupt is enabled. 1: Interrupt is masked. (default)
2	LEXZ_IM	This bit is the LEXZ interrupt mask. 0: Interrupt is enabled. 1: Interrupt is masked. (default)
1	ERR_IM	This bit is the PRBS/ARB error interrupt mask. 0: Interrupt is enabled. 1: Interrupt is masked. (default)
0	CNTOV_IM	This bit is the ERRCH and ERRCL registers overflow interrupt mask. 0: Interrupt is enabled. 1: Interrupt is masked. (default)

STAT0 - Status Register 0

Address: 01EH, 05EH, 09EH, 0DEH, 11EH, 15EH, 19EH, 1DEH, (CH1~CH8)
 21EH, 25EH, 29EH, 2DEH, 31EH, 35EH, 39EH, 3DEH, (CH9~CH16)
 41EH, 45EH, 49EH, 4DEH, 51EH, (CH17~CH21)
 7DEH (CH0)

Type: Read

Default Value: 00H

7	6	5	4	3	2	1	0
AUTOLP_S	-	-	TOC_S	TCKLOS_S	TLOS_S	SLOS_S	LLOS_S

Bit	Name	Description
7	AUTOLP_S	This bit indicates the automatic Digital/Remote Loopback status. 0: Out of automatic Digital/Remote Loopback. (default) 1: In automatic Digital/Remote Loopback.
6 - 5	-	Reserved.
4	TOC_S	This bit indicates the TOC status. 0: No TOC is detected. (default) 1: TOC is detected.
3	TCKLOS_S	This bit indicates the TCLKn missing status. 0: TCLKn is not missing. (default) 1: TCLKn is missing.
2	TLOS_S	This bit indicates the TLOS status. 0: No TLOS is detected. (default) 1: TLOS is detected.
1	SLOS_S	This bit indicates the SLOS status. 0: No SLOS is detected. (default) 1: SLOS is detected.
0	LLOS_S	This bit indicates the LLOS status. 0: No LLOS is detected. (default) 1: LLOS is detected.

STAT1 - Status Register 1

Address: 01FH, 05FH, 09FH, 0DFH, 11FH, 15FH, 19FH, 1DFH, (CH1~CH8)
 21FH, 25FH, 29FH, 2DFH, 31FH, 35FH, 39FH, 3DFH, (CH9~CH16)
 41FH, 45FH, 49FH, 4DFH, 51FH, (CH17~CH21)
 7DFH (CH0)

Type: Read

Default Value: 00H

7	6	5	4	3	2	1	0
SAIS_S	LAIS_S	PA_S	-	-	-	IBA_S	IBD_S

Bit	Name	Description
7	SAIS_S	This bit indicates the SAIS status. 0: No SAIS is detected. (default) 1: SAIS is detected.
6	LAIS_S	This bit indicates the LAIS status. 0: No LAIS is detected. (default) 1: LAIS is detected.
5	PA_S	This bit indicates the PRBS/ARB pattern synchronization status. 0: The PRBS/ARB pattern is out of synchronization. (default) 1: The PRBS/ARB pattern is in synchronization.
4 - 2	-	Reserved.
1	IBA_S	This bit indicates the activate IB code status. 0: No activate IB code is detected. (default) 1: Activate IB code is detected for more than 40 ms when the AUTOLP bit (b3, LOOP,...) is '0' or activate IB code is detected for more than 5.1 sec. when the AUTOLP bit (b3, LOOP,...) is '1'.
0	IBD_S	This bit indicates the deactivate IB code status. 0: No deactivate IB code is detected. (default) 1: Deactivate IB code is detected for more than 30 ms when the AUTOLP bit (b3, LOOP,...) is '0' or deactivate IB code is detected for more than 5.1 sec. when the AUTOLP bit (b3, LOOP,...) is '1'.

INTS0 - Interrupt Status Register 0

Address: 020H, 060H, 0A0H, 0E0H, 120H, 160H, 1A0H, 1E0H, (CH1~CH8)
 220H, 260H, 2A0H, 2E0H, 320H, 360H, 3A0H, 3E0H, (CH9~CH16)
 420H, 460H, 4A0H, 4E0H, 520H, (CH17~CH21)
 7E0H (CH0)

Type: Read / Write

Default Value: 00H

7	6	5	4	3	2	1	0
DAC_IS	TJA_IS	RJA_IS	TOC_IS	TCKLOS_IS	TLOS_IS	SLOS_IS	LLOS_IS

Bit	Name	Description
7	DAC_IS	This bit indicates the interrupt status of the waveform amplitude overflow. 0: No waveform amplitude overflow interrupt is generated; or a '1' is written to this bit. (default) 1: Waveform amplitude overflow interrupt is generated and is reported by the $\overline{\text{INT}}$ pin.
6	TJA_IS	This bit indicates the interrupt status of the TJA FIFO overflow or underflow. 0: No TJA FIFO overflow or underflow interrupt is generated; or a '1' is written to this bit. (default) 1: TJA FIFO overflow or underflow interrupt is generated and is reported by the $\overline{\text{INT}}$ pin.
5	RJA_IS	This bit indicates the interrupt status of the RJA FIFO overflow or underflow. 0: No RJA FIFO overflow or underflow interrupt is generated; or a '1' is written to this bit. (default) 1: RJA FIFO overflow or underflow interrupt is generated and is reported by the $\overline{\text{INT}}$ pin.
4	TOC_IS	This bit indicates the interrupt status of the Line Driver TOC. 0: No TOC interrupt is generated; or a '1' is written to this bit. (default) 1: TOC interrupt is generated and is reported by the $\overline{\text{INT}}$ pin. When the TOC_IES bit (b4, INTES,...) is '0', a transition from '0' to '1' on the TOC_S bit (b4, STAT0,...) set this bit to '1'; when the TOC_IES bit (b4, INTES,...) is '1', any transition (from '0' to '1' or from '1' to '0') on the TOC_S bit (b4, STAT0,...) set this bit to '1'.
3	TCKLOS_IS	This bit indicates the interrupt status of the TCLKn missing. 0: No TCLKn missing interrupt is generated; or a '1' is written to this bit. (default) 1: TCLKn missing interrupt is generated and is reported by the $\overline{\text{INT}}$ pin. When the TCKLOS_IES bit (b3, INTES,...) is '0', a transition from '0' to '1' on the TCKLOS_S bit (b3, STAT0,...) set this bit to '1'; when the TCKLOS_IES bit (b3, INTES,...) is '1', any transition (from '0' to '1' or from '1' to '0') on the TCKLOS_S bit (b3, STAT0,...) set this bit to '1'.
2	TLOS_IS	This bit indicates the interrupt status of TLOS. 0: No TLOS interrupt is generated; or a '1' is written to this bit. (default) 1: TLOS interrupt is generated and is reported by the $\overline{\text{INT}}$ pin. When the TLOS_IES bit (b2, INTES,...) is '0', a transition from '0' to '1' on the TLOS_S bit (b2, STAT0,...) set this bit to '1'; when the TLOS_IES bit (b2, INTES,...) is '1', any transition (from '0' to '1' or from '1' to '0') on the TLOS_S bit (b2, STAT0,...) set this bit to '1'.
1	SLOS_IS	This bit indicates the interrupt status of the SLOS. 0: No SLOS interrupt is generated; or a '1' is written to this bit. (default) 1: SLOS interrupt is generated and is reported by the $\overline{\text{INT}}$ pin. When the LOS_IES bit (b1, INTES,...) is '0', a transition from '0' to '1' on the SLOS_S bit (b1, STAT0,...) set this bit to '1'; when the LOS_IES bit (b1, INTES,...) is '1', any transition (from '0' to '1' or from '1' to '0') on the SLOS_S bit (b1, STAT0,...) set this bit to '1'.
0	LLOS_IS	This bit indicates the interrupt status of the LLOS. 0: No LLOS interrupt is generated; or a '1' is written to this bit. (default) 1: LLOS interrupt is generated and is reported by the $\overline{\text{INT}}$ pin. When the LOS_IES bit (b1, INTES,...) is '0', a transition from '0' to '1' on the LLOS_S bit (b0, STAT0,...) set this bit to '1'; when the LOS_IES bit (b1, INTES,...) is '1', any transition (from '0' to '1' or from '1' to '0') on the LLOS_S bit (b0, STAT0,...) set this bit to '1'.

INTS1 - Interrupt Status Register 1

Address: 021H, 061H, 0A1H, 0E1H, 121H, 161H, 1A1H, 1E1H, (CH1~CH8)
 221H, 261H, 2A1H, 2E1H, 321H, 361H, 3A1H, 3E1H, (CH9~CH16)
 421H, 461H, 4A1H, 4E1H, 521H, (CH17~CH21)
 7E1H (CH0)

Type: Read / Write

Default Value: 00H

7	6	5	4	3	2	1	0
SAIS_IS	LAIS_IS	PA_IS	-	-	-	IBA_IS	IBD_IS

Bit	Name	Description
7	SAIS_IS	This bit indicates the interrupt status of the SAIS. 0: No SAIS interrupt is generated; or a '1' is written to this bit. (default) 1: SAIS interrupt is generated and is reported by the $\overline{\text{INT}}$ pin. When the AIS_IES bit (b6, INTES,...) is '0', a transition from '0' to '1' on the SAIS_S bit (b7, STAT1,...) set this bit to '1'; when the AIS_IES bit (b6, INTES,...) is '1', any transition (from '0' to '1' or from '1' to '0') on the SAIS_S bit (b7, STAT1,...) set this bit to '1'.
6	LAIS_IS	This bit indicates the interrupt status of the LAIS. 0: No LAIS interrupt is generated; or a '1' is written to this bit. (default) 1: LAIS interrupt is generated and is reported by the $\overline{\text{INT}}$ pin. When the AIS_IES bit (b6, INTES,...) is '0', a transition from '0' to '1' on the LAIS_S bit (b6, STAT1,...) set this bit to '1'; when the AIS_IES bit (b6, INTES,...) is '1', any transition (from '0' to '1' or from '1' to '0') on the LAIS_S bit (b6, STAT1,...) set this bit to '1'.
5	PA_IS	This bit indicates the interrupt status of the PRBS/ARB pattern synchronization. 0: No PRBS/ARB pattern synchronization interrupt is generated; or a '1' is written to this bit. (default) 1: PRBS/ARB pattern synchronization interrupt is generated and is reported by the $\overline{\text{INT}}$ pin. When the PA_IES bit (b5, INTES,...) is '0', a transition from '0' to '1' on the PA_S bit (b5, STAT1,...) set this bit to '1'; when the PA_IES bit (b5, INTES,...) is '1', any transition (from '0' to '1' or from '1' to '0') on the PA_S bit (b5, STAT1,...) set this bit to '1'.
4 - 2	-	Reserved.
1	IBA_IS	This bit indicates the interrupt status of the activate IB code. 0: No activate IB code interrupt is generated; or a '1' is written to this bit. (default) 1: Activate IB code interrupt is generated and is reported by the $\overline{\text{INT}}$ pin. When the IB_IES bit (b0, INTES,...) is '0', a transition from '0' to '1' on the IBA_S bit (b1, STAT1,...) set this bit to '1'; when the IB_IES bit (b0, INTES,...) is '1', any transition (from '0' to '1' or from '1' to '0') on the IBA_S bit (b1, STAT1,...) set this bit to '1'.
0	IBD_IS	This bit indicates the interrupt status of the deactivate IB code. 0: No deactivate IB code interrupt is generated; or a '1' is written to this bit. (default) 1: Deactivate IB code interrupt is generated and is reported by the $\overline{\text{INT}}$ pin. When the IB_IES bit (b0, INTES,...) is '0', a transition from '0' to '1' on the IBD_S bit (b0, STAT1,...) set this bit to '1'; when the IB_IES bit (b0, INTES,...) is '1', any transition (from '0' to '1' or from '1' to '0') on the IBD_S bit (b0, STAT1,...) set this bit to '1'.

INTS2 - Interrupt Status Register 2

Address: 022H, 062H, 0A2H, 0E2H, 122H, 162H, 1A2H, 1E2H, (CH1~CH8)
 222H, 262H, 2A2H, 2E2H, 322H, 362H, 3A2H, 3E2H, (CH9~CH16)
 422H, 462H, 4A2H, 4E2H, 522H, (CH17~CH21)
 7E2H (CH0)

Type: Read / Write

Default Value: 00H

7	6	5	4	3	2	1	0
-	-	SBPV_IS	LBPV_IS	SEXZ_IS	LEXZ_IS	ERR_IS	CNTOV_IS

Bit	Name	Description
7 - 6	-	Reserved.
5	SBPV_IS	This bit indicates the interrupt status of the SBPV. 0: No SBPV interrupt is generated; or a '1' is written to this bit. (default) 1: SBPV interrupt is generated and is reported by the $\overline{\text{INT}}$ pin.
4	LBPV_IS	This bit indicates the interrupt status of the LBPV. 0: No LBPV interrupt is generated; or a '1' is written to this bit. (default) 1: LBPV interrupt is generated and is reported by the $\overline{\text{INT}}$ pin.
3	SEXZ_IS	This bit indicates the interrupt status of the SEXZ. 0: No SEXZ interrupt is generated; or a '1' is written to this bit. (default) 1: SEXZ interrupt is generated and is reported by the $\overline{\text{INT}}$ pin.
2	LEXZ_IS	This bit indicates the interrupt status of the LEXZ. 0: No LEXZ interrupt is generated; or a '1' is written to this bit. (default) 1: LEXZ interrupt is generated and is reported by the $\overline{\text{INT}}$ pin.
1	ERR_IS	This bit indicates the interrupt status of the PRBS/ARB error. 0: No PRBS/ARB error interrupt is generated; or a '1' is written to this bit. (default) 1: PRBS/ARB error interrupt is generated and is reported by the $\overline{\text{INT}}$ pin.
0	CNTOV_IS	This bit indicates the interrupt status of the ERRCH and ERRCL registers overflow. 0: No ERRCH or ERRCL register overflow interrupt is generated; or a '1' is written to this bit. (default) 1: ERRCH and ERRCL registers overflow interrupt is generated and is reported by the $\overline{\text{INT}}$ pin.

ERRCL - Error Counter Low-Byte Register

Address: 023H, 063H, 0A3H, 0E3H, 123H, 163H, 1A3H, 1E3H, (CH1~CH8)
 223H, 263H, 2A3H, 2E3H, 323H, 363H, 3A3H, 3E3H, (CH9~CH16)
 423H, 463H, 4A3H, 4E3H, 523H, (CH17~CH21)
 7E3H (CH0)

Type: Read

Default Value: 00H

7	6	5	4	3	2	1	0
ERRC7	ERRC6	ERRC5	ERRC4	ERRC3	ERRC2	ERRC1	ERRC0
Bit	Name	Description					
7 - 0	ERRC[7:0]	These bits, together with the ERRC[15:8] bits, reflect the accumulated error number in the internal Error Counter. They are updated automatically or manually, as determined by the CNT_MD bit (b1, ERR,...). They should be read in the next round of error counting; otherwise, they will be overwritten.					

ERRCH - Error Counter High-Byte Register

Address: 024H, 064H, 0A4H, 0E4H, 124H, 164H, 1A4H, 1E4H, (CH1~CH8)
 224H, 264H, 2A4H, 2E4H, 324H, 364H, 3A4H, 3E4H, (CH9~CH16)
 424H, 464H, 4A4H, 4E4H, 524H, (CH17~CH21)
 7E4H (CH0)

Type: Read

Default Value: 00H

7	6	5	4	3	2	1	0
ERRC15	ERRC14	ERRC13	ERRC12	ERRC11	ERRC10	ERRC9	ERRC8
Bit	Name	Description					
7 - 0	ERRC[15:8]	(Refer to the description of the ERRCL register.)					

JM - Jitter Measurement Configuration For Channel 0 Register

Address: 7E5H Type: Read / Write Default Value: 00H							
7	6	5	4	3	2	1	0
-	-	-	-	-	JM_STOP	JM_MD	JM_BW
Bit	Name	Description					
7 - 3	-	Reserved.					
2	JM_STOP	This bit is valid only when the JM_MD bit (b1, JM) is '0'. A transition from '0' to '1' on this bit updates the JIT_PH, JIT_PL and JIT_NH, JIT_NL registers. This bit must be cleared before the next round.					
1	JM_MD	This bit selects the jitter measurement period. 0: The period is determined manually by setting the JM_STOP bit (b2, JM). (default) 1: The period is one second automatically.					
0	JM_BW	This bit selects the bandwidth of the measured jitter. 0: 20 Hz ~ 100 KHz. (default) 1: 18 KHz ~ 100 KHz.					

JIT_PL - Positive Peak Jitter Measurement Low-Byte Register

Address: 7E6H Type: Read Default Value: 00H							
7	6	5	4	3	2	1	0
JIT_P7	JIT_P6	JIT_P5	JIT_P4	JIT_P3	JIT_P2	JIT_P1	JIT_P0
Bit	Name	Description					
7 - 0	JIT_P[7:0]	These bits, together with the JIT_P[11:8] bits, reflect the greatest positive peak value of the demodulated jitter signal which is measured by channel 0. They are updated automatically or manually, as determined by the JM_MD bit (b1, JM). They should be read in the next round of jitter measurement; otherwise, they will be overwritten. The relationship between the greatest positive peak value and the indication in these bits is: Positive Peak = [JIT_PH, JIT_PL] / 16 (U _{pp})					

JIT_PH - Positive Peak Jitter Measurement High-Byte Register

Address: 7E7H Type: Read Default Value: 00H							
7	6	5	4	3	2	1	0
-	-	-	-	JIT_P11	JIT_P10	JIT_P9	JIT_P8
Bit	Name	Description					
7 - 4	-	Reserved.					
3 - 0	JIT_P[11:8]	(Refer to the description of the JIT_PL register.)					

JIT_NL - Negative Peak Jitter Measurement Low-Byte Register

Address: 7E8H							
Type: Read							
Default Value: 00H							
7	6	5	4	3	2	1	0
JIT_N7	JIT_N6	JIT_N5	JIT_N4	JIT_N3	JIT_N2	JIT_N1	JIT_N0
Bit	Name	Description					
7 - 0	JIT_N[7:0]	These bits, together with the JIT_N[11:8] bits, reflect the greatest negative peak value of the demodulated jitter signal which is measured by channel 0. They are updated automatically or manually, as determined by the JM_MD bit (b1, JM). They should be read in the next round of jitter measurement; otherwise, they will be overwritten. The relationship between the greatest negative peak value and the indication in these bits is: Negative Peak = [JIT_NH, JIT_NL] / 16 (Upp)					

JIT_NH - Negative Peak Jitter Measurement High-Byte Register

Address: 7E9H							
Type: Read							
Default Value: 00H							
7	6	5	4	3	2	1	0
-	-	-	-	JIT_N11	JIT_N10	JIT_N9	JIT_N8
Bit	Name	Description					
7 - 4	-	Reserved.					
3 - 0	JIT_N[11:8]	(Refer to the description of the JIT_NL register.)					

6 JTAG

The IDT82P2521 supports the digital Boundary Scan Specification as described in the IEEE 1149.1 standards.

The boundary scan architecture consists of data and instruction registers plus a Test Access Port (TAP) controller. The control of the TAP is achieved through signals applied to the Test Mode Select (TMS) and Test Clock (TCK) input pins. Data is shifted into the registers via the Test

Data Input (TDI) pin, and shifted out of the registers via the Test Data Output (TDO) pin. Both TDI and TDO are clocked at a rate determined by TCK.

The JTAG boundary scan registers include BSR (Boundary Scan Register), DIR (Device Identification Register), BR (Bypass Register) and IR (Instruction Register). These will be described in the following pages. Refer to Figure-47 for architecture.

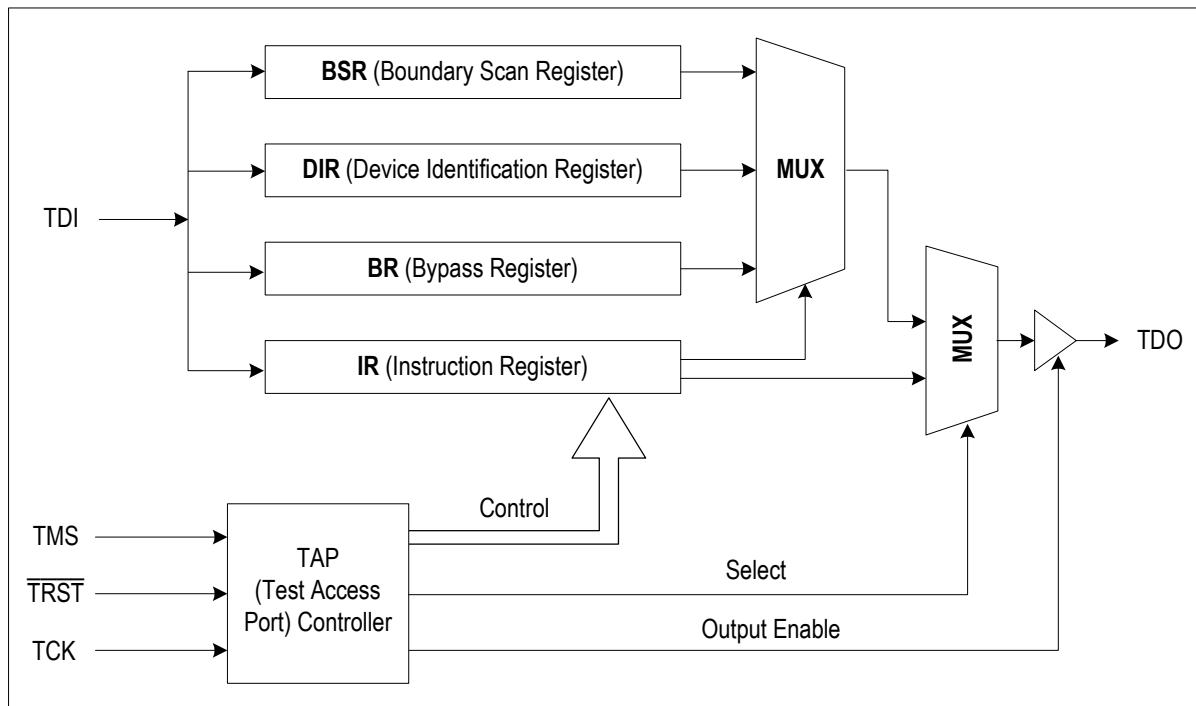

Figure-47 JTAG Architecture

6.1 JTAG INSTRUCTION REGISTER (IR)

The IR with instruction decode block is used to select the test to be executed or the data register to be accessed or both.

The instructions include: EXTEST, SAMPLE/PRELOAD, IDCODE, BYPASS, CLAMP and HIGHZ.

6.2 JTAG DATA REGISTER

6.2.1 DEVICE IDENTIFICATION REGISTER (IDR)

The IDR can be set to define the Version, the Part Number, the Manufacturer Identity and a fixed bit.

6.2.2 BYPASS REGISTER (BYP)

The BYP consists of a single bit. It can provide a serial path between the TDI input and the TDO output. Bypassing the BYR will reduce test access times.

6.2.3 BOUNDARY SCAN REGISTER (BSR)

The bidirectional ports interface to 2 boundary scan cells:

- In cell: The input cell is observable only.
- Out cell: The output cell is controllable and observable.

6.3 TEST ACCESS PORT (TAP) CONTROLLER

The TAP controller is a 16-state synchronous state machine. The states include: Test Logic Reset, Run-Test/Idle, Select-DR-Scan, Capture-DR, Shift-DR, Exit1-DR, Pause-DR, Exit2-DR, Update-DR, Select-IR-Scan, Capture-IR, Shift-IR, Exit1-IR, Pause-IR, Exit2-IR and Update-IR.

Figure-48 shows the state diagram. Note that the figure contains two main branches to access either the data or instruction registers. The value shown next to each state transition in this figure states the value present at TMS at each rising edge of TCK.

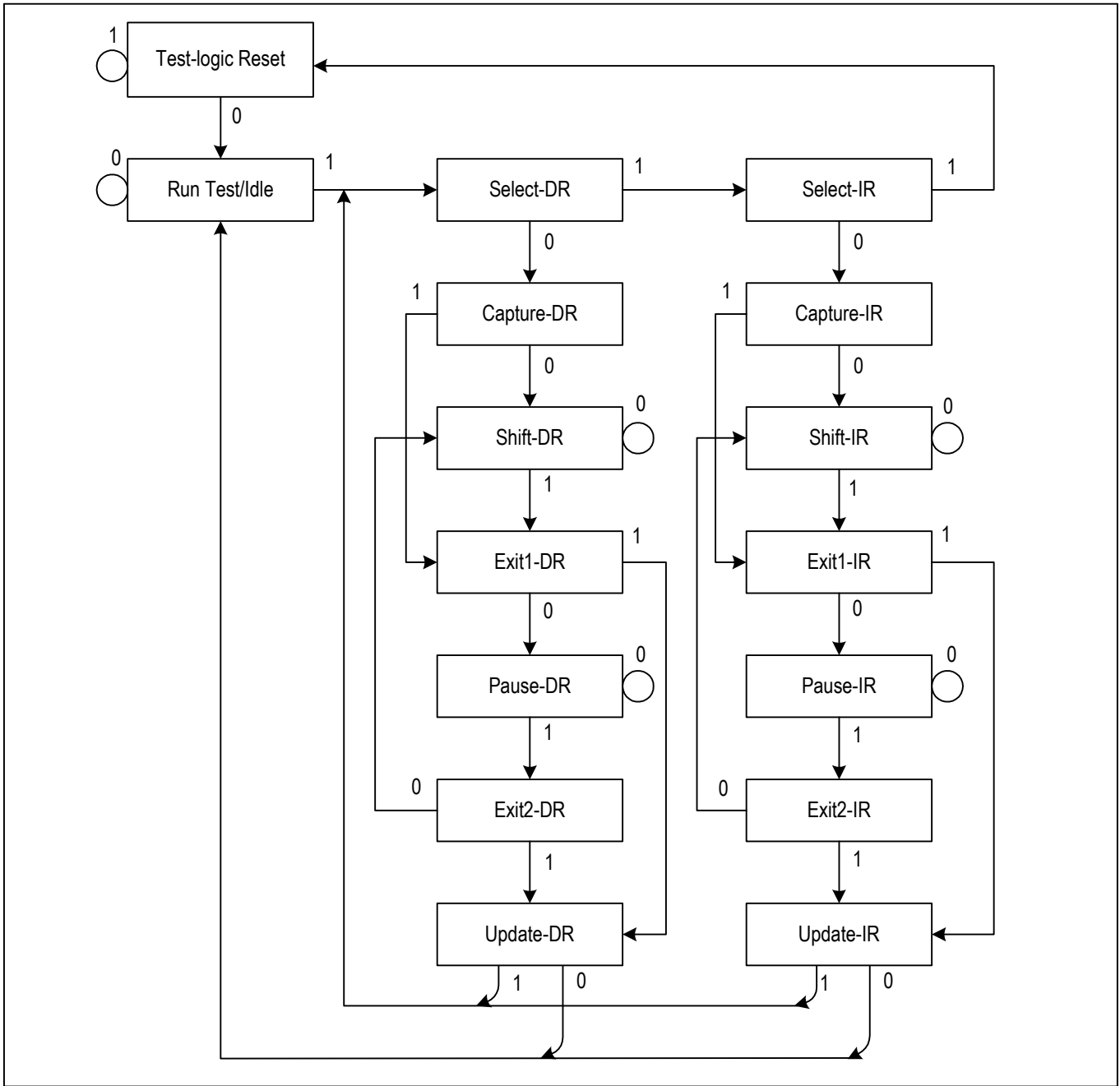

Figure-48 JTAG State Diagram

7 THERMAL MANAGEMENT

The device is designed to operate over the industry temperature range $-40^{\circ}\text{C} \sim +85^{\circ}\text{C}$. To ensure the functionality and reliability of the device, the maximum junction temperature, $T_{j\text{max}}$, should not exceed 125°C . In some applications, the device will consume more power and a thermal solution should be provided to ensure the junction temperature T_j does not exceed $T_{j\text{max}}$. Below is a table listing thermal data for the IDT82P2521.

Package	θ_{JC} ($^{\circ}\text{C}/\text{W}$) ¹	θ_{JB} ($^{\circ}\text{C}/\text{W}$) ²	θ_{JA} ($^{\circ}\text{C}/\text{W}$) ³	Airflow (m/s)
640-pin TEPBGA	4.90	8.50	16.7	0
			12.8	1
			11.3	2
			10.5	3
			10.1	4
			9.9	5

Note:

1. Junction-to-Case Thermal Resistance
2. Junction-to-Board Thermal Resistance
3. Junction-to-Ambient Thermal Resistance

7.1 JUNCTION TEMPERATURE

Junction temperature T_j is the temperature of package typically at the geographical center of the chip where the device's electrical circuits are. It can be calculated as follows:

$$\text{Equation 1: } T_j = T_A + P * \theta_{\text{JA}}$$

Where:

θ_{JA} = Junction-to-Ambient Thermal Resistance of the package

T_j = Junction Temperature

T_A = Ambient Temperature

P = Device Power Consumption

For the IDT82P2521, the above values are:

$\theta_{\text{JA}} = 16.7^{\circ}\text{C}/\text{W}$ (when airflow rate is 0 m/s. See the above table)

$T_{j\text{max}} = 125^{\circ}\text{C}$

$T_A = -40^{\circ}\text{C} \sim 85^{\circ}\text{C}$

P = Refer to Section 8.3 Device Power Consumption and Dissipation (Typical) 1

7.2 EXAMPLE OF JUNCTION TEMPERATURE CALCULATION

Assume:

$$T_A = 85^{\circ}\text{C}$$

$$\theta_{\text{JA}} = 12.8^{\circ}\text{C}/\text{W} \text{ (airflow: 1 m/s)}$$

$$P = 1.95 \text{ W (E1 120 } \Omega, 100\% \text{ ones, External Impedance matching)}$$

The junction temperature T_j can be calculated as follows:

$$T_j = T_A + P * \theta_{\text{JA}} = 85^{\circ}\text{C} + 1.95 \text{ W} \times 12.8^{\circ}\text{C}/\text{W} = 110.0^{\circ}\text{C}$$

The junction temperature of 110.0°C is below the maximum junction temperature of 125°C , so no extra heat enhancement is required.

In some operation environments, the calculated junction temperature might exceed the maximum junction temperature of 125°C and an external thermal solution such as a heatsink is required.

7.3 HEATSINK EVALUATION

A heatsink is expanding the surface area of the device to which it is attached. θ_{JA} is now a combination of device case and heatsink thermal resistance, as the heat flowing from the die junction to ambient goes through the package and the heatsink. θ_{JA} can be calculated as follows:

$$\text{Equation 2: } \theta_{\text{JA}} = \theta_{\text{JC}} + \theta_{\text{HA}}$$

Where:

θ_{JC} = Junction-to-Case (heatsink) Thermal Resistance

θ_{HA} = Heatsink-to-Ambient Thermal Resistance

For the IDT82P2521, θ_{JC} is $4.90^{\circ}\text{C}/\text{W}$.

θ_{HA} determines which heatsink can be selected to ensure the junction temperature does not exceed $T_{j\text{max}}$. According to Equation 1 and 2, the heatsink-to-ambient thermal resistance θ_{HA} can be calculated as follows:

$$\text{Equation 3: } \theta_{\text{HA}} = (T_j - T_A) / P - \theta_{\text{JC}}$$

Assume:

$$T_j = 125^{\circ}\text{C} (T_{j\text{max}})$$

$$T_A = 85^{\circ}\text{C}$$

$$P = 3.53 \text{ W (E1 75 } \Omega, 100\% \text{ ones, Fully Internal Impedance matching)}$$

$$\theta_{\text{JC}} = 4.90^{\circ}\text{C}/\text{W}$$

The Heatsink-to-Ambient thermal resistance θ_{HA} can be calculated as follows:

$$\theta_{\text{HA}} = (125^{\circ}\text{C} - 85^{\circ}\text{C}) / 3.53 \text{ W} - 4.90^{\circ}\text{C}/\text{W} = 6.43^{\circ}\text{C}/\text{W}$$

That is, if a heatsink whose heatsink-to-ambient thermal resistance θ_{HA} is below or equal to $6.43^{\circ}\text{C}/\text{W}$ is used in such operation environment, the junction temperature will not exceed the maximum junction temperature.

8 PHYSICAL AND ELECTRICAL SPECIFICATIONS

8.1 ABSOLUTE MAXIMUM RATINGS

Symbol	Parameter	Min	Max	Unit
VDDD	Digital Core Power Supply	-0.5	2.2	V
VDDA	Analog Core Power Supply	-0.5	4.6	V
VDDIO	I/O Power Supply	-0.5	4.6	V
VDDT0~21	Power Supply for Transmitter Driver	-0.5	4.6	V
VDDR0~21	Power Supply for Receiver	-0.5	4.6	V
V_{in}	Input Voltage, Any Digital Pin	GND - 0.5	6	V
	Input Voltage, Any RTIP and RRING pin ¹	GND - 0.5	VDDR + 0.5	V
	ESD Voltage, Any Pin ²	2000		V
I_{in}	Transient Latch-up Current, Any Pin		100	mA
	Input Current, Any Digital Pin ³	-10	10	mA
	DC Input Current, Any Analog Pin ³		±100	mA
Pd	Maximum Power Dissipation in Package		2.4 ⁴	W
T_j	Junction Temperature		125	°C
T_s	Storage Temperature	-65	+150	°C

Note:

1. Reference to ground.
2. Human body model.
3. Constant input current.
4. If device power consumption exceeds this value, a heatsink must be used. Refer to Chapter 7 Thermal Management.

Caution:

Exceeding the above values may cause permanent damage. Functional operation under these conditions is not implied. Exposure to absolute maximum rating conditions for extended period may affect device reliability.

8.2 RECOMMENDED OPERATING CONDITIONS

Symbol	Parameter	Min	Typ.	Max	Unit
T_{op}	Operating Temperature Range	-40		85 ¹	°C
VDDIO	Digital I/O Power Supply	3.13	3.3	3.47	V
VDDA	Analog Core Power Supply	3.13	3.3	3.47	V
VDDD	Digital Core Power Supply	1.71	1.8	1.89	V
VDDT	Power Supply for Transmitter Driver	3.13	3.3	3.47	V
VDDR	Power Supply for Receiver	3.13	3.3	3.47	V
V_{IL}	Input Low Voltage	-0.5		0.8	V
V_{IH}	Input High Voltage	2.0		VDDIO+0.5	V

Note:

1. An external thermal solution such as heatsink may be required depending on the mode of operation. Refer to Chapter 7 Thermal Management.

8.3 DEVICE POWER CONSUMPTION AND DISSIPATION (TYPICAL) ¹

Mode	Parameter	Total Consumption (W)			Total Device Power Dissipation (for Thermal Consideration, W)			Per-Channel Power Down Saving (mW) ²		
		1.8 V	3.3 V	Total	Fully Internal R120IN=1 ³	Partially Internal R120IN=0 ⁴	External ⁵	Fully Internal R120IN=1 ³	Partially Internal R120IN=0 ⁴	External ⁵
E1/120 Ω	PRBS	0.23	2.22	2.45	2.45	1.88	1.59	80	60	40
	100% ones	0.23	3.00	3.23	3.23	2.40	1.95	130	90	70
E1/75 Ω	PRBS	0.23	2.40	2.62	2.62	2.28	1.64	90	60	50
	100% ones	0.23	3.30	3.53	3.53	3.01	2.06	150	120	80

Note:

1. Test conditions: VDDx (typical) at 25 °C operating temperature (ambient).
2. The R_OFF bit (b5, RCF0,...) and T_OFF bit (b5, TCF0,...) are set to '1' to enable per-channel power down.
3. The transmitter is in Internal Impedance Matching mode and the receiver is in Fully Internal Impedance Matching mode. That is, the R120IN bit (b4, RCF0,...) is set to '1'. And the T_TERM[2:0] bits (b2~0, TCF0,...) and R_TERM[2:0] bits (b2~0, RCF0,...) are set according to different cable conditions.
4. The transmitter is in Internal Impedance Matching mode and the receiver is in Partially Internal Impedance Matching mode. That is, the R120IN bit (b4, RCF0,...) is set to '0'. And the T_TERM[2:0] bits (b2~0, TCF0,...) and R_TERM[2:0] bits (b2~0, RCF0,...) are set according to different cable conditions.
5. For E1 mode, both the transmitter and the receiver are in External Impedance Matching mode. That is, the T_TERM[2:0] bits (b2~0, TCF0,...) are set to '111' and the R_TERM[2:0] bits (b2~0, RCF0,...) are set to '1xx'.

8.4 DEVICE POWER CONSUMPTION AND DISSIPATION (MAXIMUM) ¹

Mode	Parameter	Total Consumption (W)			Total Device Power Dissipation (for Thermal Consideration, W)		
		1.89 V	3.47 V	Total	Fully Internal R120IN=1 ²	Partially Internal R120IN=0 ³	External ⁴
E1/120 Ω	PRBS	0.27	2.39	2.66	2.66	2.09	1.71
	100% ones	0.28	3.20	3.48	3.48	2.64	2.07
E1/75 Ω	PRBS	0.27	2.55	2.82	2.82	2.47	1.71
	100% ones	0.27	3.50	3.78	3.78	3.26	2.12

- Note:**
1. Test conditions: VDDx (maximum) at 85 °C operating temperature (ambient).
 2. The transmitter is in Internal Impedance Matching mode and the receiver is in Fully Internal Impedance Matching mode. That is, the R120IN bit (b4, RCF0,...) is set to '1'. And the T_TERM[2:0] bits (b2~0, TCF0,...) and R_TERM[2:0] bits (b2~0, RCF0,...) are set according to different cable conditions.
 3. The transmitter is in Internal Impedance Matching mode and the receiver is in Partially Internal Impedance Matching mode. That is, the R120IN bit (b4, RCF0,...) is set to '0'. And the T_TERM[2:0] bits (b2~0, TCF0,...) and R_TERM[2:0] bits (b2~0, RCF0,...) are set according to different cable conditions.
 4. For E1 mode, both the transmitter and the receiver are in External Impedance Matching mode. That is, the T_TERM[2:0] bits (b2~0, TCF0,...) are set to '111' and the R_TERM[2:0] bits (b2~0, RCF0,...) are set to '1xx'.

8.5 D.C. CHARACTERISTICS

@ TA = -40 to +85 °C, VDDIO = 3.3 V ± 5%, VDDD = 1.8 V ± 5%

Symbol	Parameter	Min	Typ.	Max	Unit	Test Conditions
V _{OL}	Output Low Voltage			0.40	V	VDDIO = 3.13 V, I _{OL} = 4 mA, 8 mA
V _{OH}	Output High Voltage	2.4		VDDIO	V	VDDIO = 3.13 V, I _{OH} = 4 mA, 8 mA
V _{T+}	Schmitt Trigger Input Low to High Threshold	1.8			V	
V _{T-}	Schmitt Trigger Input High to Low Threshold			0.7	V	
R _{pu}	Internal Pull-up /Pull-down Resistor	50	70	115	KΩ	
I _{IL}	Input Low Current	-1	0	+1	μA	V _{IL} = GNDD
I _{IH}	Input High Current	-1	0	+1	μA	V _{IH} = VDDIO
C _{in}	Input Digital Pin Capacitance			10	pF	
C _{out}	Output Load Capacitance			50	pF	
C _{out}	Output Load Capacitance (bus pins)			100	pF	
I _{ZL}	Leakage Current of Digital Output in High-Z mode	-10		10	μA	GNDIO < V _O < VDDIO
Z _{OH}	Output High-Z on TTIPn, TRINGn pins	10			KΩ	

8.6 E1 RECEIVER ELECTRICAL CHARACTERISTICS

Parameter	Min	Typ.	Max	Unit	Test Conditions
Receiver Sensitivity of Receive Differential mode with Cable Loss @ 1024 KHz		15		dB	with Nominal Pulse Amplitude of 3.0 V for 120 Ω and 2.37 V for 75 Ω termination, adding -18 dB interference signal.
Receiver Sensitivity of Receive Single Ended mode with Cable Loss @ 1024 KHz		12		dB	
Signal to Noise Interference Margin	-14			dB	@cable loss 0-6 dB
Analog LOS Level (Normal Mode)	ALOS[2:0]			V_{pp}	In Differential mode, measured between RTIP and RRING pins. In Singled Ended mode, measured between RTIP and GNDA pins Refer to Table-9 for LLOS Criteria Declare and Clear.
	000	0.5			
	001 (default)	0.7			
	010	0.9			
	011	1.2			
	100	1.4			
	101	1.6			
	110	1.8			
	111	2.0			
	LOS hysteresis	0.25			
Analog LOS Level (Line Monitor Mode)	ALOS[2:0]			V_{pp}	Measured on the line with the monitor gain set by the MG[1:0] bits (b1~0, RCF2,...) equal to the resistive attenuation. Refer to Table-9 for LLOS Criteria Declare and Clear.
	000	1.0			
	001 (default)	1.4			
	010	1.8			
	011	2.2			
	1xx (reserved)				
	LOS hysteresis	0.41			
Allowable Consecutive Zeros before LOS: G.775 I.431 / ETSI300233		32 2048			
LOS Reset	12.5			% ones	G.775, ETSI 300233
Receive Intrinsic Jitter			0.05	U.I.	JA disabled; wide band
Input Jitter Tolerance: 1 Hz ~ 20 Hz 20 Hz ~ 2.4 KHz 18 KHz ~ 100 KHz	37 5 2			U.I. U.I. U.I.	G.823, with 6 dB Cable Attenuation
Receiver Differential Input Impedance		2.6		K Ω	@1024 KHz; Rx port is high-Z
Receiver Common Mode Input Impedance to GND		1.6		K Ω	
Receiver Single Ended mode Input Impedance to GND		3.1		K Ω	The RRINGn pins are open.
Receive Return Loss: 51 KHz ~ 102 KHz 102 KHz ~ 2.048 MHz 2.048 MHz ~ 3.072 MHz	12 18 14			dB dB dB	G.703
Receive Path Delay: Single Rail Dual Rail NRZ Dual Rail RZ			6.6 1.8 1.5	U.I. U.I. U.I.	JA Disabled

8.8 TRANSMITTER AND RECEIVER TIMING CHARACTERISTICS

Symbol	Parameter	Min	Typ.	Max	Unit
	MCLK Frequency: E1		2.048 X n (n = 1 ~ 8)		MHz
	MCLK Tolerance	-100		100	ppm
	MCLK Duty Cycle	30		70	%
Transmit Path					
	TCLK Frequency: E1		2.048		MHz
	TCLK Tolerance	-50		+50	ppm
	TCLK Duty Cycle	10		90	%
t1	Transmit Data Setup Time	40			ns
t2	Transmit Data Hold Time	40			ns
	Delay Time of OE low to Driver High-Z			1	μs
	Delay Time of TCLK low to Driver High-Z		TBD		μs
Receive Path					
	Clock Recovery Capture Range ¹ : E1		+80 / -80		ppm
	RCLK Duty Cycle ²	40	50	60	%
t4	RCLK Pulse Width ² : E1	457	488	519	ns
t5	RCLK Pulse Width Low Time: E1	203	244	285	ns
t6	RCLK Pulse Width High Time: E1	203	244	285	ns
	Rise/Fall Time ³	20			ns
t7	Receive Data Setup Time: E1	200	244		ns
t8	Receive Data Hold Time: E1	200	244		ns
Note: 1. Relative to nominal frequency, MCLK = +100 or -100 ppm. 2. RCLK duty cycle width will vary depending on extent of the received pulse jitter displacement. Maximum and minimum RCLK duty cycles are for worst case jitter conditions (0.2 UI displacement for E1 per ITU G.823). 3. For all digital outputs. C _{load} = 15 pF.					

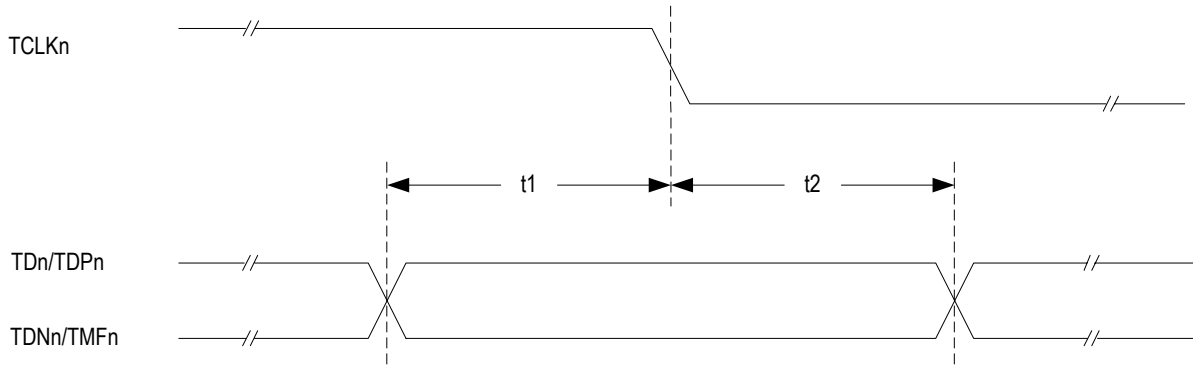

Figure-49 Transmit Clock Timing Diagram

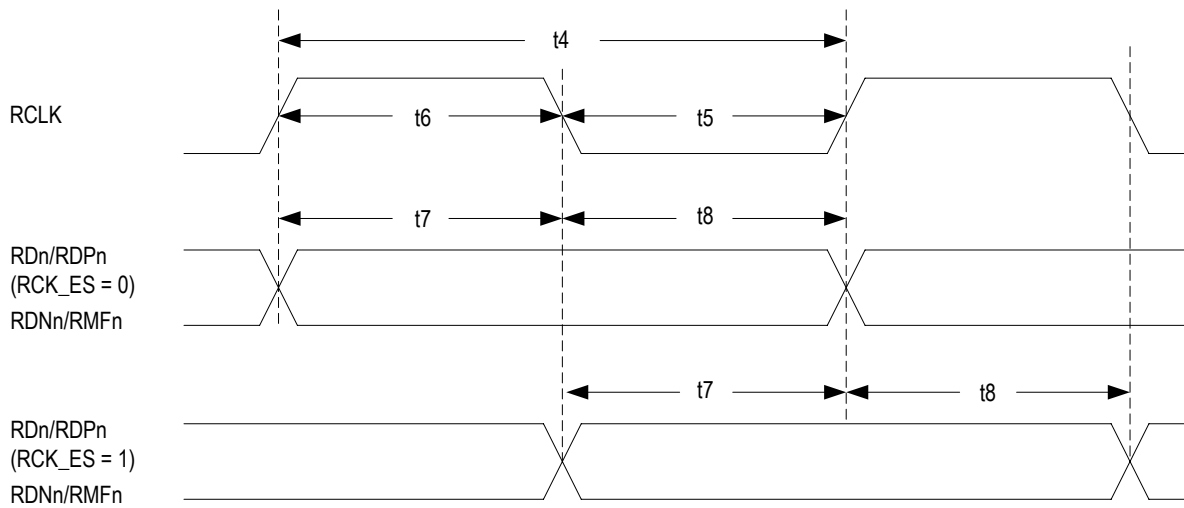

Figure-50 Receive Clock Timing Diagram

8.9 CLKE1 TIMING CHARACTERISTICS

Symbol	Parameter	Min	Typ.	Max	Unit
CLKE1 outputs 2.048 MHz clock					
t1	CLKE1 Pulse Width		488		ns
t2	CLKE1 Pulse Width High Time	232	244	256	ns
t3	CLKE1 Pulse Width Low Time	232	244	256	ns
t4	LLOS Data Setup Time	217	244	271	ns
t5	LLOS Data Hold Time	217	244	271	ns
CLKE1 outputs 8kHz clock					
t1	CLKE1 Pulse Width		125		μs
t2	CLKE1 Pulse Width High Time	62.4	62.5	62.6	μs
t3	CLKE1 Pulse Width Low Time	62.4	62.5	62.6	μs
t4	LLOS Data Setup Time	62.38	62.5	62.62	μs
t5	LLOS Data Hold Time	62.38	62.5	62.62	μs

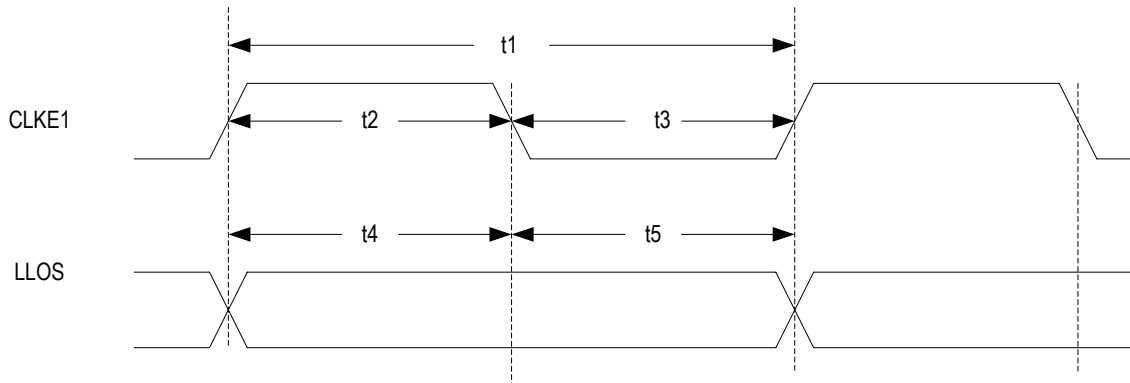

Figure-51 CLKE1 Clock Timing Diagram

8.10 JITTER ATTENUATION CHARACTERISTICS

Parameter	Min	Typ.	Max	Unit
Jitter Transfer Function Corner (-3 dB) Frequency:				
E1, 32/64/128-bit FIFO		6.63		Hz
JA_BW = 0		0.87		Hz
JA_BW = 1				

Parameter	Min	Typ.	Max	Unit
Jitter Attenuator: E1 (G.736)	@ 3 Hz	-0.5		dB
	@ 40 Hz	-0.5		dB
	@ 400 Hz	+19.5		dB
	@ 100 KHz	+19.5		dB
Jitter Attenuator Latency Delay:				
	32-bit FIFO		16	U.I.
	64-bit FIFO		32	U.I.
			64	U.I.
Input Jitter Tolerance before FIFO Overflow or Underflow:				
	32-bit FIFO		28	U.I.
	64-bit FIFO		56	U.I.
	128-bit FIFO		120	U.I.

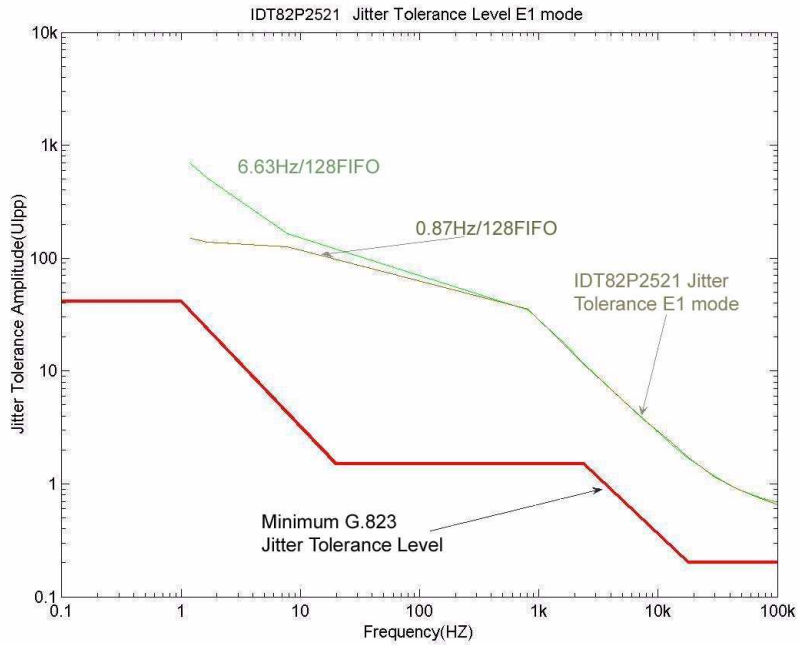

Figure-52 E1 Jitter Tolerance Performance

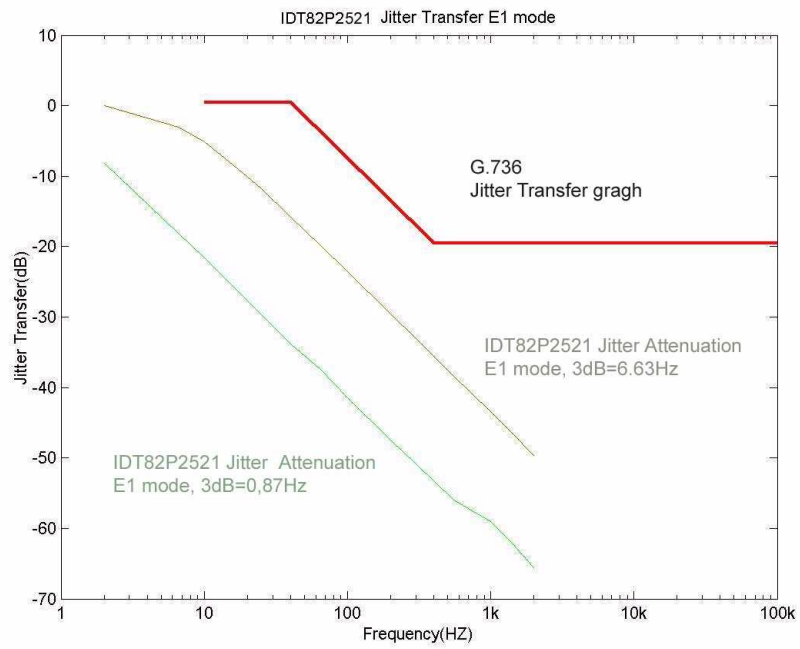

Figure-53 E1 Jitter Transfer Performance

8.11 MICROPROCESSOR INTERFACE TIMING

8.11.1 SERIAL MICROPROCESSOR INTERFACE

A falling transition on \overline{CS} indicates the start of a read/write operation, and a rising transition indicates the end of the operation. After \overline{CS} is set to low, a 5-bit instruction on SDI is input to the device on the rising edge of SCLK. If the MSB is '1', it is a read operation. If the MSB is '0', it is a

write operation. Following the instruction, an 11-bit address is clocked in on SDI to specify the register. If the device is in a read operation, the data read from the specified register is output on SDO on the falling edge of SCLK (refer to Figure-54). If the device is in a write operation, the data written to the specified register is input on SDI following the address byte (refer to Figure-55).

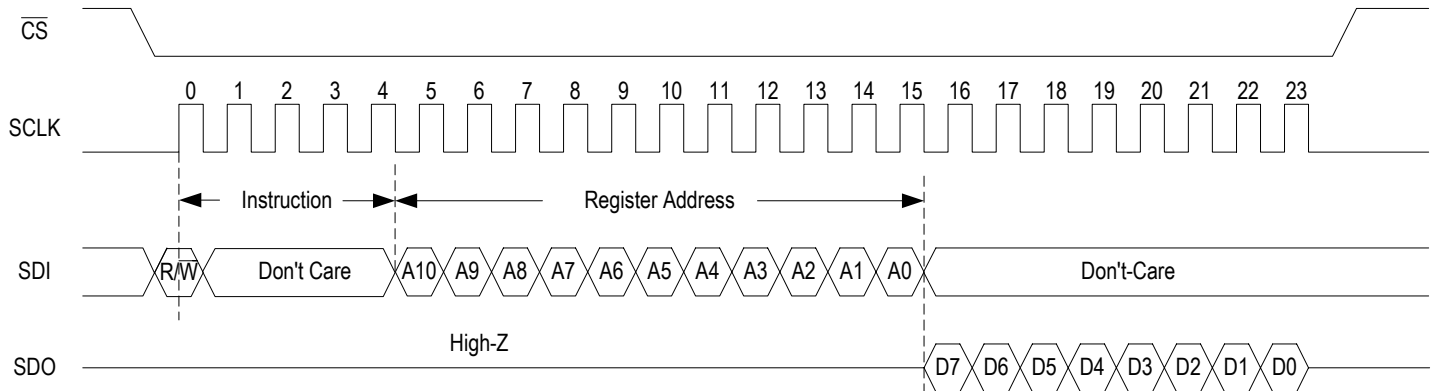

Figure-54 Read Operation in Serial Microprocessor Interface

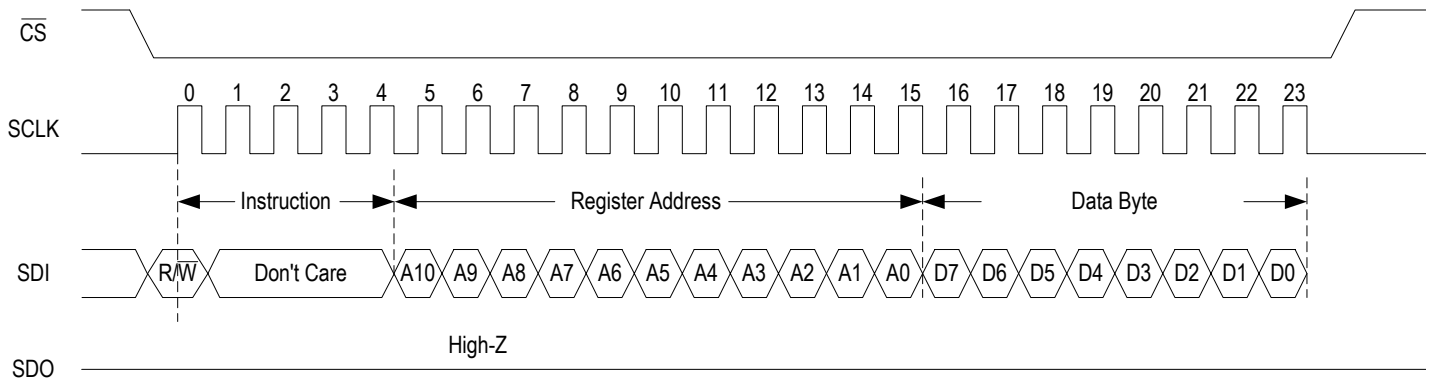

Figure-55 Write Operation in Serial Microprocessor Interface

Symbol	Description	Min.	Max.	Units
f_{OP}	SCLK Frequency		2.0	MHz
t_{CSH}	Minimum \overline{CS} High Time	100		ns
t_{CSS}	\overline{CS} Setup Time	50		ns
t_{CSD}	\overline{CS} Hold Time	100		ns
t_{CLD}	Clock Disable Time	50		ns
t_{CLH}	Clock High Time	205		ns
t_{CLL}	Clock Low Time	205		ns
t_{DIS}	Data Setup Time	50		ns
t_{DIH}	Data Hold Time	150		ns
t_{PD}	Output Delay		150	ns
t_{DF}	Output Disable Time		50	ns

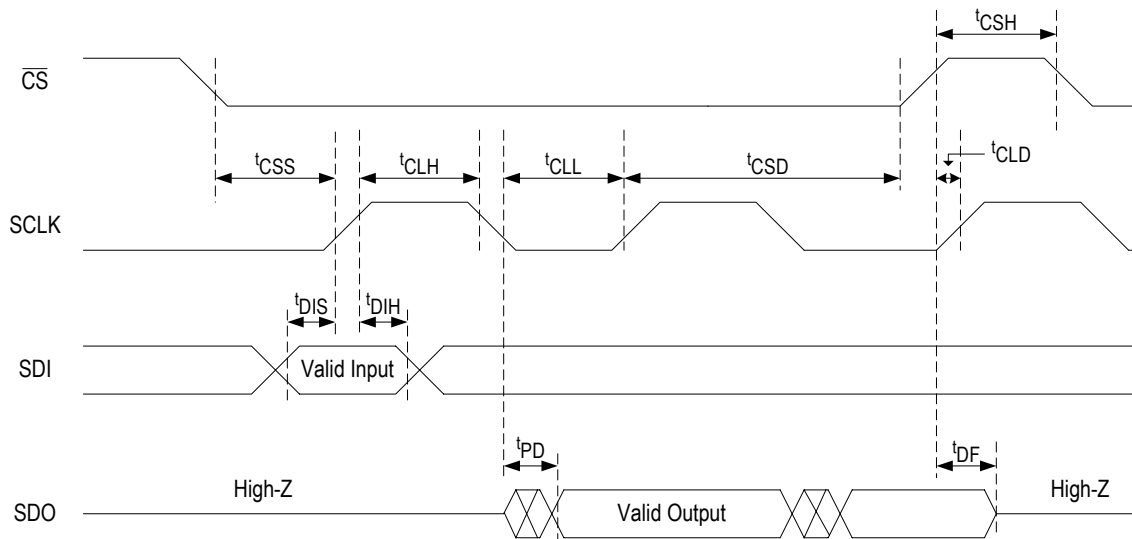

Figure-56 Timing Diagram

8.11.2 PARALLEL MOTOROLA NON-MULTIPLEXED MICROPROCESSOR INTERFACE

8.11.2.1 Read Cycle Specification

Symbol	Parameter	Min	MAX	Units
t_{SAR}	Address to valid read setup time	5		ns
t_{RSW}	Valid read signal width	38 or wait until \overline{ACK} activated		ns
t_{HAR}	Address to valid read hold time	0		ns
t_{RWV}	R/\overline{W} available time after valid $\overline{CS} + \overline{DS}$ signal falling edge	0		ns
t_{RWH}	R/\overline{W} hold time after valid $\overline{CS} + \overline{DS}$ signal falling edge	33		ns
t_{PRD}	Data propagation delay after valid $\overline{CS} + \overline{DS}$ signal falling edge		33	ns
t_{ZRD}	Valid read negated to output High-Z	5	20	ns

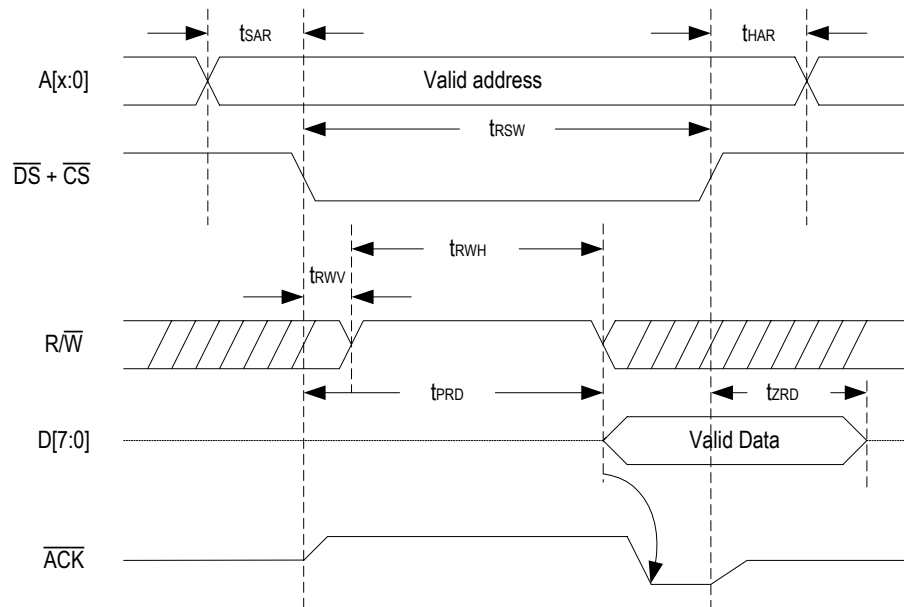

Figure-57 Parallel Motorola Non-Multiplexed Microprocessor Interface Read Cycle

8.11.2 Write Cycle Specification

Symbol	Parameter	Min	MAX	Units
t_{SAW}	Address to valid write setup time	0		ns
t_{WSW}	Valid write signal width	5 or wait until \overline{ACK} activated		ns
t_{HAW}	Address to valid write hold time	35		ns
t_{RWV}	R/\overline{W} available time after valid write signal falling edge	0		ns
t_{RWH}	R/\overline{W} hold time after valid write signal falling edge	5 or wait until \overline{ACK} activated		ns
t_{DV}	Data available time before valid write signal rising edge	5		ns
t_{DH}	Valid data hold time after valid write signal rising edge	5		ns
t_{REC}	Recovery time from write cycle	5		ns

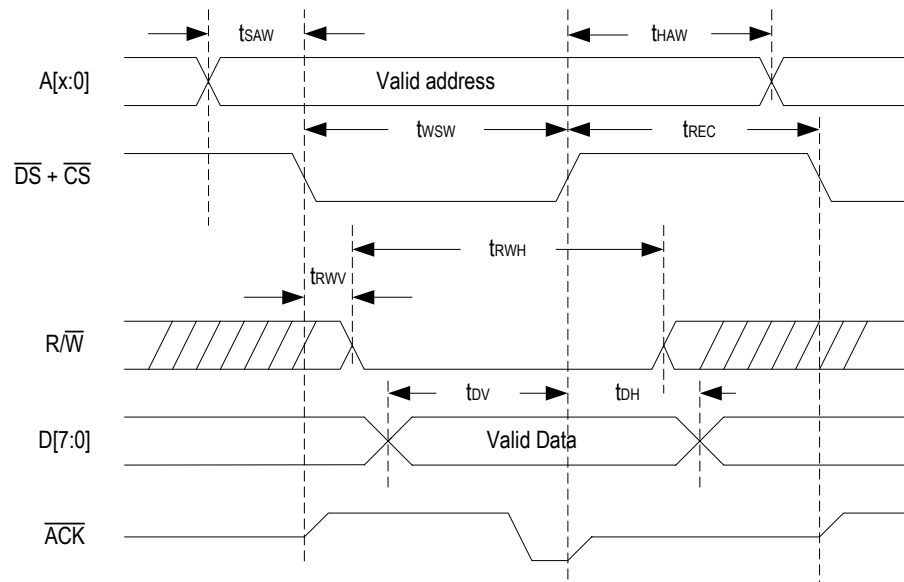
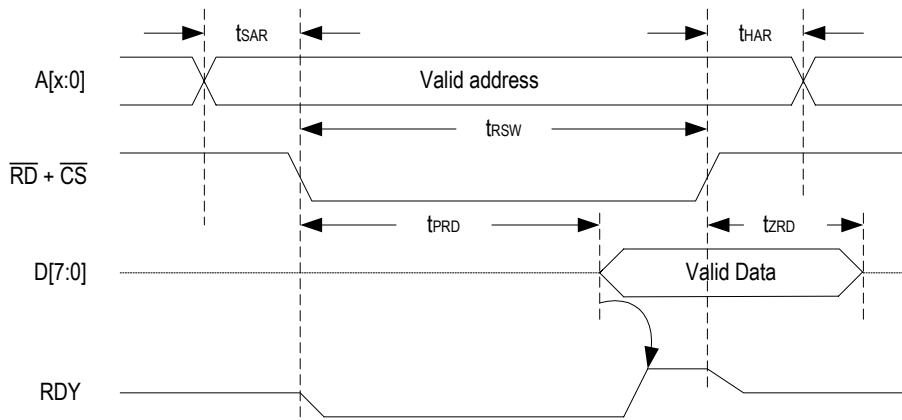

Figure-58 Parallel Motorola Non-Multiplexed Microprocessor Interface Write Cycle

8.11.3 PARALLEL INTEL NON-MULTIPLEXED MICROPROCESSOR INTERFACE

8.11.3.1 Read Cycle Specification

Symbol	Parameter	Min	MAX	Units
t_{SAR}	Address to valid read setup time	5		ns
t_{RSW}	Valid read signal width	33 or wait until RDY activated		ns
t_{HAR}	Address to valid read hold time	0		ns
t_{PRD}	Data propagation delay after valid read signal falling edge		28	ns
t_{ZRD}	Valid read negated to output High-Z	5	20	ns



Note: \overline{WR} shall be tied to high.

Figure-59 Parallel Intel Non-Multiplexed Microprocessor Interface Read Cycle

8.11.3.2 Write Cycle Specification

Symbol	Parameter	Min	MAX	Units
t_{SAW}	Address to valid write setup time	0		ns
t_{WSW}	Valid write signal width	5 or wait until RDY activated		ns
t_{HAW}	Address to valid write hold time	35		ns
t_{DV}	Data available time before valid write signal rising edge	5		ns
t_{DH}	Valid data hold time after valid write signal rising edge	5		ns
t_{REC}	Recovery time from write cycle	5		ns

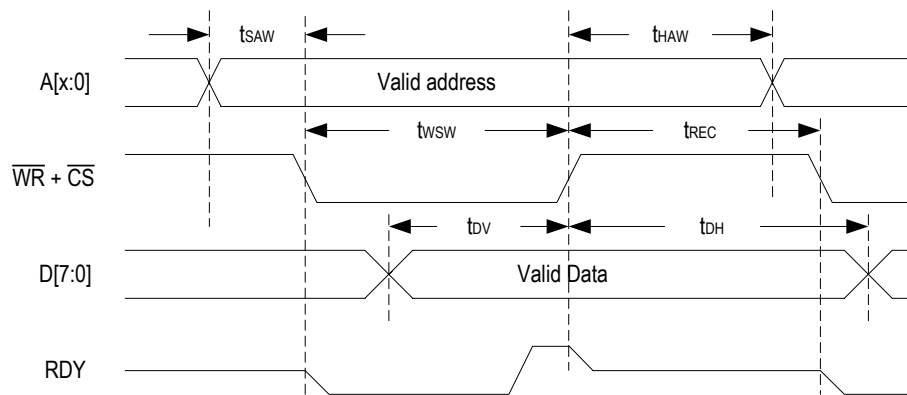

Note: \overline{RD} shall be tied to high.

Figure-60 Parallel Intel Non-Multiplexed Microprocessor Interface Write Cycle

8.11.4 PARALLEL MOTOROLA MULTIPLEXED MICROPROCESSOR INTERFACE

8.11.4.1 Read Cycle Specification

Symbol	Parameter	Min	MAX	Units
t_{ASW}	Valid AS signal width	5		ns
t_{RSW}	Valid read signal width	38 or wait until \overline{ACK} activated		ns
t_{CSD}	Valid $\overline{DS} + \overline{CS}$ falling edge delay after AS	0		ns
t_{RWV}	R/\overline{W} available time after valid $\overline{DS} + \overline{CS}$ signal falling edge	0		ns
t_{RWH}	R/\overline{W} hold time after valid $\overline{DS} + \overline{CS}$ signal falling edge	33		ns
t_{VAS}	Valid address to AS setup time	5		ns
t_{VAH}	Valid address to AS hold time	5		ns
t_{PRD}	Data propagation delay after valid $\overline{DS} + \overline{CS}$ signal falling edge		33	ns
t_{ZRD}	Valid read negated to output High-Z before valid AS rising edge	5	20	ns

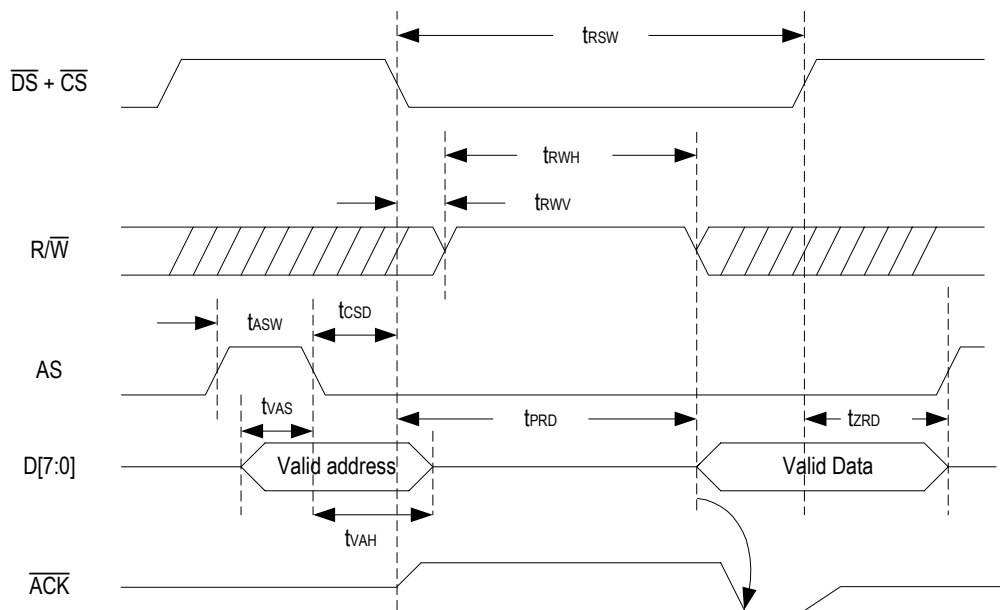

Figure-61 Parallel Motorola Multiplexed Microprocessor Interface Read Cycle

8.11.4.2 Write Cycle Specification

Symbol	Parameter	Min	MAX	Units
t_{ASW}	Valid AS signal width	5		ns
t_{WSW}	Valid write signal width	5 or wait until \overline{ACK} activated		ns
t_{HCW}	$\overline{DS} + \overline{CS}$ to valid hold time	35		ns
t_{RWW}	R/\overline{W} available time after valid write signal falling edge	0		ns
t_{RWH}	R/\overline{W} hold time after valid write signal falling edge	5		ns
t_{CSD}	Valid $\overline{DS} + \overline{CS}$ falling edge delay after AS	0		ns
t_{VAS}	Valid address to AS setup time	5		ns
t_{VAH}	Valid address to AS hold time	5		ns
t_{ASD}	Valid AS rising edge delay after $\overline{DS} + \overline{CS}$ rising edge	5		ns
t_{DV}	Data available time before valid write signal rising edge	5		ns
t_{DH}	Valid data hold time after valid write signal rising edge before the next AS rising edge	5		ns

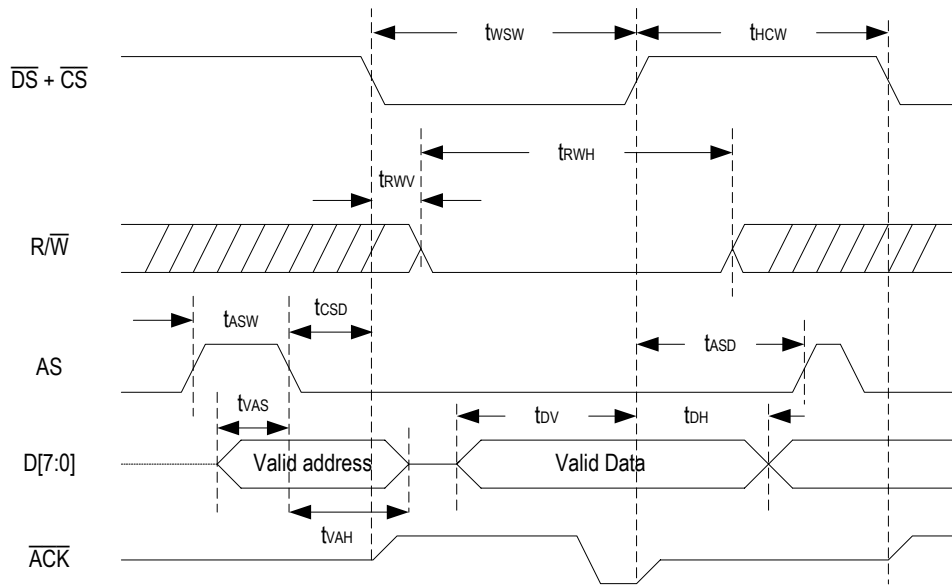
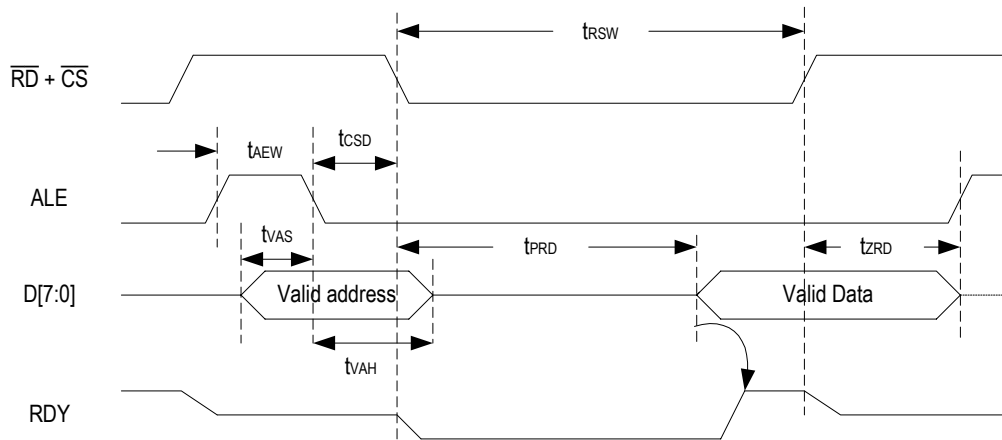

Figure-62 Parallel Motorola Multiplexed Microprocessor Interface Write Cycle

8.11.5 PARALLEL INTEL MULTIPLEXED MICROPROCESSOR INTERFACE

8.11.5.1 Read Cycle Specification

Symbol	Parameter	Min	MAX	Units
t_{AEW}	Valid ALE signal width	5		ns
t_{RSW}	Valid read signal width	33 or wait until RDY activated		ns
t_{CSD}	Valid $\overline{RD} + \overline{CS}$ falling edge delay after ALE falling edge	0		ns
t_{VAS}	Valid address to ALE setup time	5		ns
t_{VAH}	Valid address to ALE hold time	5		ns
t_{PRD}	Data propagation delay after valid read signal falling edge		28	ns
t_{ZRD}	Valid read negated to output High-Z before valid ALE rising edge	5	20	ns



Note: \overline{WR} shall be tied to high.

Figure-63 Parallel Intel Multiplexed Microprocessor Interface Read Cycle

8.11.5.2 Write Cycle Specification

Symbol	Parameter	Min	MAX	Units
t_{AEW}	Valid ALE signal width	5		ns
t_{WSW}	Valid write signal width	5 or wait until RDY activated		ns
t_{HCW}	$\overline{WR} + \overline{CS}$ to valid hold time	35		ns
t_{CSD}	Valid $\overline{WR} + \overline{CS}$ falling edge delay after ALE falling edge	0		ns
t_{VAS}	Valid address to ALE setup time	5		ns
t_{VAH}	Valid address to ALE hold time	5		ns
t_{AED}	Valid ALE rising edge delay after $\overline{WR} + \overline{CS}$ rising edge	5		ns
t_{DV}	Data available time before valid write signal rising edge	5		ns
t_{DH}	Valid data hold time after valid write signal rising edge before the next AS rising edge	5		ns

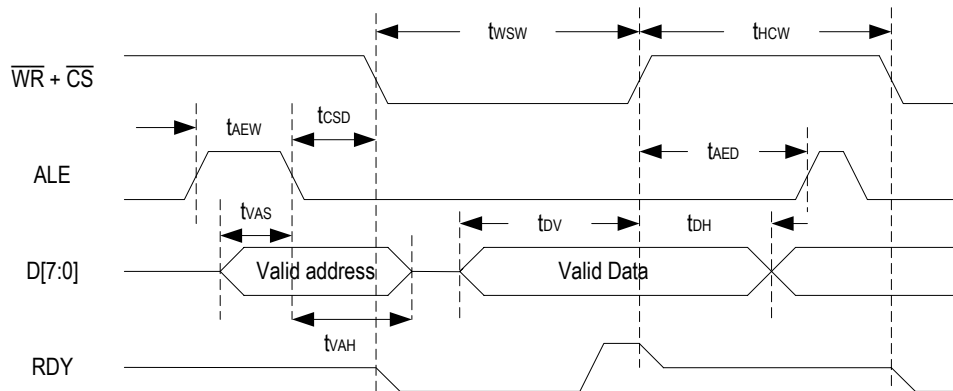

Note: \overline{RD} shall be tied to high.

Figure-64 Parallel Intel Multiplexed Microprocessor Interface Write Cycle

8.12 JTAG TIMING CHARACTERISTICS

Symbol	Parameter	Min	Typ.	Max	Unit
t1	TCK Period	100			ns
t2	TMS to TCK Setup Time; TDI to TCK Setup Time	25			ns
t3	TCK to TMS Hold Time; TCK to TDI Hold Time	25			ns
t4	TCK to TDO Delay Time			50	ns

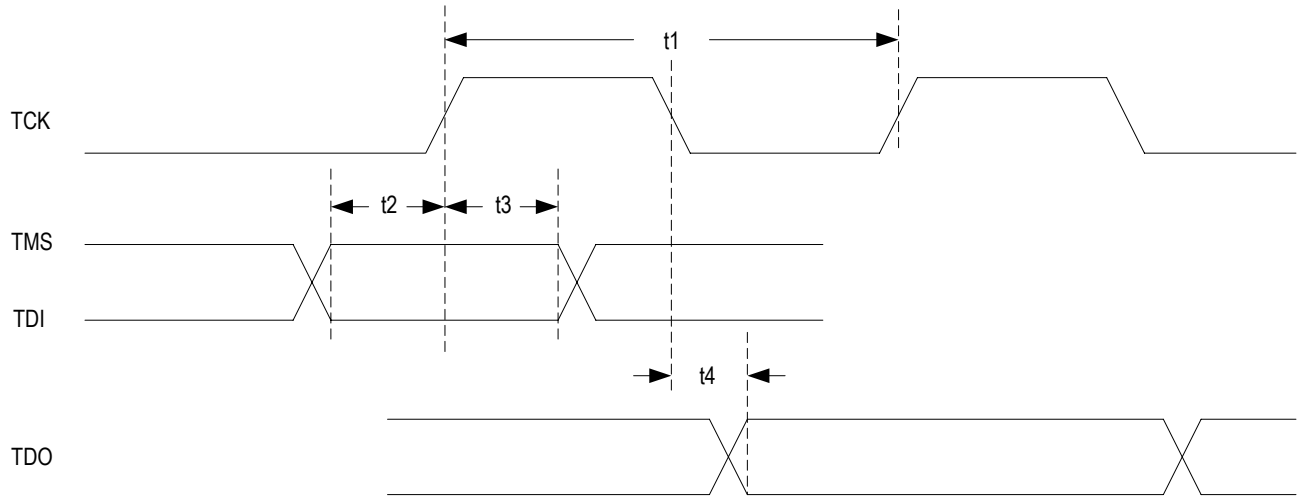

Figure-65 JTAG Timing

AIS	—	Alarm Indication Signal
AMI	—	Alternate Mark Inversion
ARB	—	Arbitrary Pattern
BPV	—	Bipolar Violation
CF	—	Corner Frequency
CV	—	Code Violation
DPLL	—	Digital Phase Locked Loop
EXZ	—	Excessive Zeroes
FIFO	—	First In First Out
HDB3	—	High Density Bipolar 3
HPS	—	Hitless Protection Switching
IB	—	Inband Loopback
LAIS	—	Line Alarm Indication Signal
LBPV	—	Line Bipolar Violation
LEXZ	—	Line Excessive Zeroes
LLOS	—	Line Loss of Signal
LOS	—	Loss Of Signal
NRZ	—	Non-Return to Zero
PBX	—	Private Branch Exchange
PRBS	—	Pseudo Random Bit Sequence
QRSS	—	Quasi-Random Signal Source
RJA	—	Receive Jitter Attenuator
RZ	—	Return to Zero
SAIS	—	System Alarm Indication Signal
SBPV	—	System Bipolar Violation
SDH	—	Synchronous Digital Hierarchy
SEXZ	—	System Excessive Zeroes

SLOS	—	System LOS
SONET	—	Synchronous Optical Network
TEPBGA	—	Thermally Enhanced Plastic Ball Grid Array
TJA	—	Transmit Jitter Attenuator
TLOS	—	Transmit Loss of Signal
TOC	—	Transmit Over Current



A		
Alarm Indication Signal (AIS)	46	
B		
Bipolar Violation (BPV)	42	
C		
cable		
coaxial cable	29, 31, 38, 39	
twisted pair cable	29, 38	
clock input		
MCLK	65	
XCLK	65	
clock output		
CLKE1	60	
REFA/REFB	61	
CLKA/CLKB	61	
MCLK	61	
recovery clock	61	
Code Violation (CV)	42	
common control	23	
Corner Frequency (CF)	41	
D		
decoder	33	
E		
encoder	35	
error counter	49	
Excessive Zeroes (EXZ)	42	
F		
free running	60, 61	
G		
G.772 Monitoring	58	
H		
heatsink	119	
high impedance	18, 29, 34, 38, 40	
Hitless Protection Switch (HPS)	29	
hitless switch	29	
hot-swap	29	
hot-switchover	29	
I		
impedance matching		
receive		
External Impedance Matching	29, 31	
Fully Internal Impedance Matching	29	
Partially Internal Impedance Matching	29	
transmit		
External Impedance Matching	38	
Internal Impedance Matching	38, 39	
Interrupt	66	
J		
JA-Limit	41	
Jitter Measurement (JM)	59	
JTAG	26, 117	
L		
line interface	18, 29, 38	
receive		
Differential	29	
Single Ended	31	
transmit		
Differential	38	
Single Ended	39	
line monitor	32	
loopback		
Analog Loopback	53	
Digital Loopback	55	
Dual Loopback		
Manual Remote Loopback + Automatic Digital Loopback	56	
Manual Remote Loopback + Manual Digital Loopback	56	
Remote Loopback	54	
Loss of Signal (LOS)	43	
Line LOS (LLOS)	43	
System LOS (SLOS)	44	
Transmit LOS (TLOS)	45	
M		
microprocessor interface	24, 69	
monitoring		

G.772 monitoring	58	Rx clock & data recovery	33
line monitor	32		
P		S	
pattern		slicer	33
ARB	47, 48	system interface	19, 33, 34
Inband Loopback (IB)	47, 49	receive	
PRBS	47, 48	Dual Rail NRZ Format	33
power down	34, 40	Dual Rail RZ Format	33
receiver	34	Dual Rail Sliced	33
transmitter	40	Single Rail NRZ Format	33
Protected Non-Intrusive Monitoring	32	transmit	
		Dual Rail NRZ Format	34
		Dual Rail RZ Format	34
		Single Rail NRZ Format	34
R		T	
receive sensitivity	32	Transmit Over Current (TOC)	38, 52
reset		W	
global software reset	69	waveform template	35
hardware reset	69		
power-on reset	69		

ORDERING INFORMATION

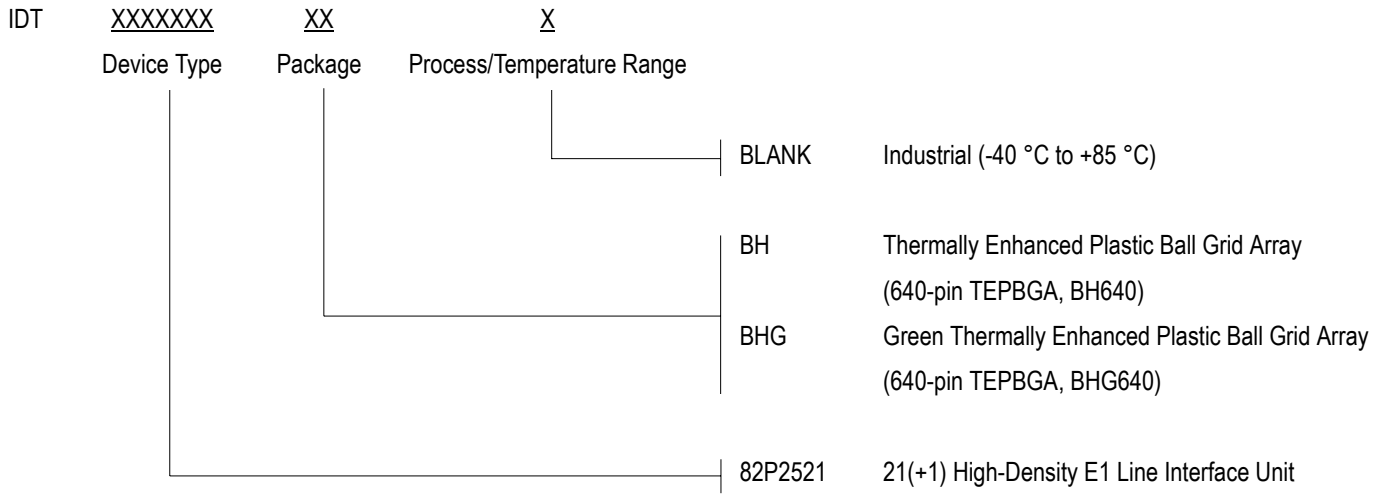

Data Sheet Document History

12/07/2005 Pages 10, 20, 23, 43, 70, 71, 72, 119, 120, 125, 132



CORPORATE HEADQUARTERS
6024 Silver Creek Valley Road
San Jose, CA 95138

for SALES:
1-800-345-7015 or 408-284-8200
fax: 408-284-2775
www.idt.com

for Tech Support:
408-360-1552
email:TELECOMhelp@idt.com

IDT and the IDT logo are trademarks of Integrated Device Technology, Inc.