

DAC1403D160

Dual 14 bits DAC, up to 160 MHz, 2 x interpolating

Rev. 03 — 2 July 2012

Product data sheet

1. General description

The DAC1403D160 is optimized to reduce architecture complexity and overall system cost. It leads to dynamic performance in multi-carrier support, because of its direct IF conversion capabilities. With an internal sampling rate of up to 160 MHz, DAC1403D160 is an extremely competitive solution for broadband wireless systems transmitters, as well as a wide range of applications.

2. Features

- Dual 14-bit resolution
- Spurious-Free Dynamic Range (SFDR) = 80 dBc at 2.5 MHz
- Input data rate up to 80 MHz
- 2 × interpolation filter
- Output data rate up to 160 MHz
- Single 3.3 V power supply
- Low noise capacitor-free integrated Phase-Locked Loop (PLL)
- Low power dissipation
- HTQFP80 package
- Ambient temperature from -40 °C to +85 °C

3. Applications

- Broadband wireless systems
- Digital radio links
- Cellular base stations
- Instrumentation
- Cable modem
- Cable Modem Termination System (CMTS)/Data Over Cable Service Interface Specification (DOCSIS)



4. Ordering information

Table 1. Ordering information

Type number	Package		Version
	Name	Description	
DAC1403D160HW	HTQFP80	plastic thermal enhanced thin quad flat package; 80 leads; body 12 × 12 × 1 mm; exposed die pad	SOT841-1

5. Block diagram

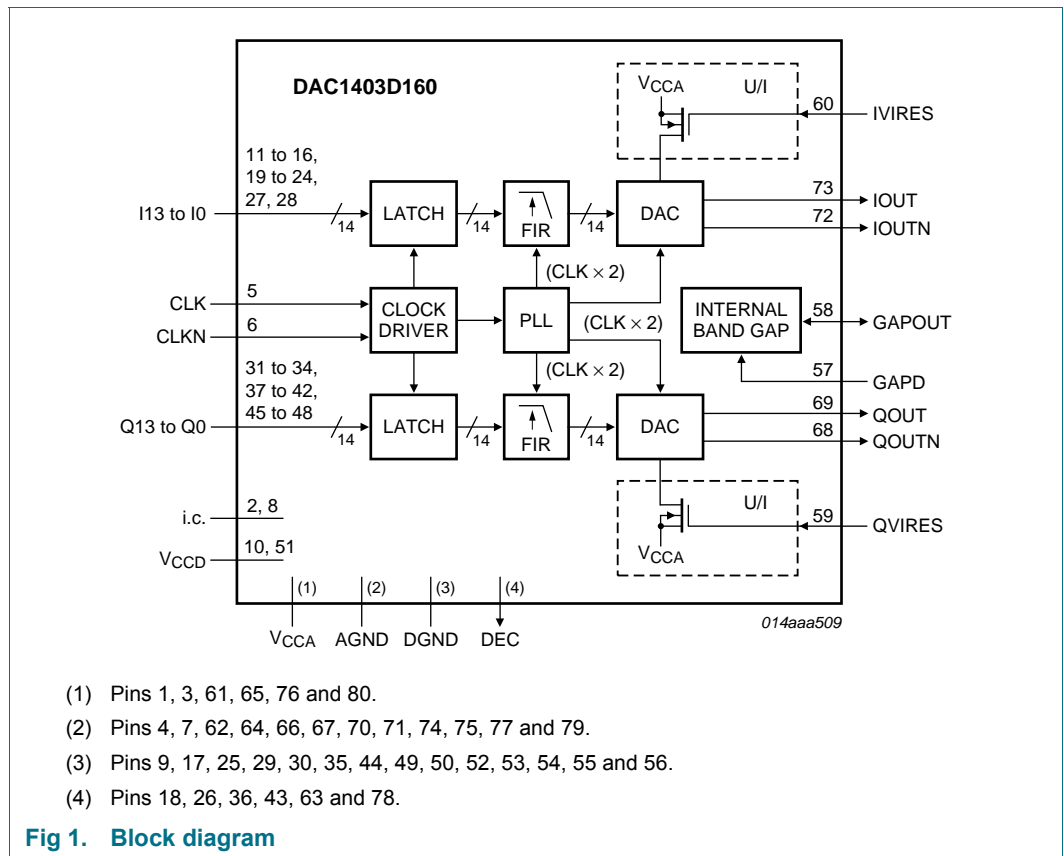

6. Pinning information

6.1 Pinning

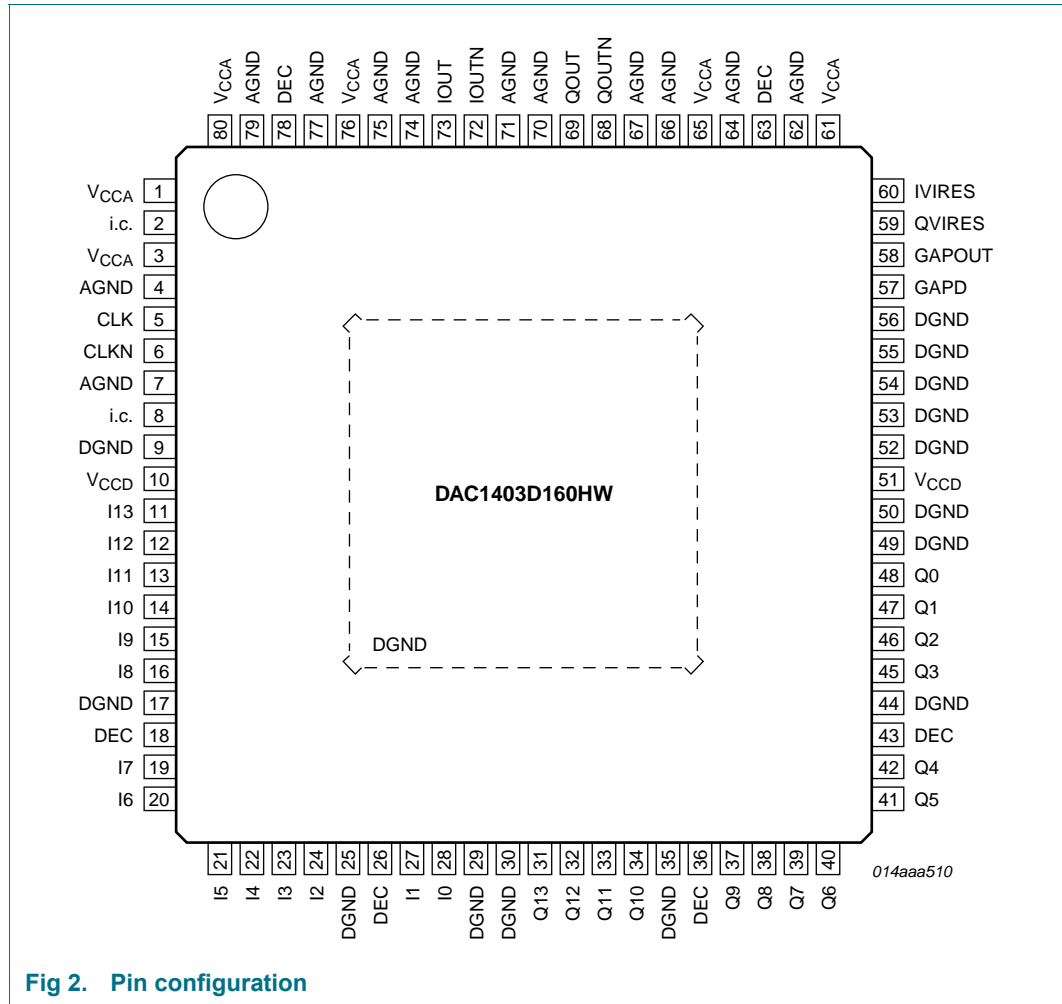

Fig 2. Pin configuration

6.2 Pin description

Table 2. Pin description

Symbol	Pin	Type ^[1]	Description
V _{CCA}	1	S	analog supply voltage
i.c.	2	I/O	internally connected; leave open
V _{CCA}	3	S	analog supply voltage
AGND	4	G	analog ground
CLK	5	I	clock input
CLKN	6	I	complementary clock input
AGND	7	G	analog ground
i.c.	8	O	internally connected; leave open
DGND	9	G	digital ground

Table 2. Pin description ...continued

Symbol	Pin	Type ^[1]	Description
V _{CCD}	10	S	digital supply voltage
I13	11	I	I data input bit 13 (Most Significant Bit (MSB))
I12	12	I	I data input bit 12
I11	13	I	I data input bit 11
I10	14	I	I data input bit 10
I9	15	I	I data input bit 9
I8	16	I	I data input bit 8
DGND	17	G	digital ground
DEC	18	O	decoupling node
I7	19	I	I data input bit 7
I6	20	I	I data input bit 6
I5	21	I	I data input bit 5
I4	22	I	I data input bit 4
I3	23	I	I data input bit 3
I2	24	I	I data input bit 2
DGND	25	G	digital ground
DEC	26	O	decoupling node
I1	27	I	I data input bit 1
I0	28	I	I data input bit 0 (Least Significant Bit (LSB))
DGND	29	G	digital ground
DGND	30	G	digital ground
Q13	31	I	Q data input bit 13 (MSB)
Q12	32	I	Q data input bit 12
Q11	33	I	Q data input bit 11
Q10	34	I	Q data input bit 10
DGND	35	G	digital ground
DEC	36	O	decoupling node
Q9	37	I	Q data input bit 9
Q8	38	I	Q data input bit 8
Q7	39	I	Q data input bit 7
Q6	40	I	Q data input bit 6
Q5	41	I	Q data input bit 5
Q4	42	I	Q data input bit 4
DEC	43	O	decoupling node
DGND	44	G	digital ground
Q3	45	I	Q data input bit 3
Q2	46	I	Q data input bit 2
Q1	47	I	Q data input bit 1
Q0	48	I	Q data input bit 0 (LSB)
DGND	49	G	digital ground
DGND	50	G	digital ground

Table 2. Pin description ...continued

Symbol	Pin	Type ^[1]	Description
V _{CCD}	51	S	digital supply voltage
DGND	52	G	digital ground
DGND	53	G	digital ground
DGND	54	G	digital ground
DGND	55	G	digital ground
DGND	56	G	digital ground
GAPD	57	I	internal band gap power disable input
GAPOUT	58	I/O	band gap output voltage
QVIRES	59	I	Q DAC biasing resistor
IVIRES	60	I	I DAC biasing resistor
V _{CCA}	61	S	analog supply voltage
AGND	62	G	analog ground
DEC	63	O	decoupling node
AGND	64	G	analog ground
V _{CCA}	65	S	analog supply voltage
AGND	66	G	analog ground
AGND	67	G	analog ground
QOUTN	68	O	complementary Q DAC output current
QOUT	69	O	Q DAC output current
AGND	70	G	analog ground
AGND	71	G	analog ground
IOUTN	72	O	complementary I DAC output current
IOUT	73	O	I DAC output current
AGND	74	G	analog ground
AGND	75	G	analog ground
V _{CCA}	76	S	analog supply voltage
AGND	77	G	analog ground
DEC	78	O	decoupling node
AGND	79	G	analog ground
V _{CCA}	80	S	analog supply voltage

[1] Type description: S: Supply; G: Ground; I: Input; O: Output.

7. Functional description

The Digital-to-Analog Converter (DAC) is a segmented architecture composed of a 7-bit thermometer sub-DAC and the remaining 7-bit in a binary weighted sub-DAC.

The device produces two complementary current outputs on both channels, respectively pins IOUT/IOUTN and QOUT/QOUTN which need to be connected via a load resistor to the ground.

Figure 3 shows the equivalent analog output circuit of one DAC, which consists of a parallel combination of PMOS current sources and associated switches for each segment.

The cascade source configuration enables the increasing of the output impedance of the source and set to improve the dynamic performance of the DAC by introducing less distortion.

Figure 4 shows the internal reference configuration. In this case the bias current is given by the output of the internal regulator connected to the inverting input of the internal operational amplifiers, while external resistors R_I and R_Q are connected respectively to pins IVIRES and QVIRES. Thus the output current of the two DACs is typically fixed to 20 mA with an appropriate choice of these resistors. This configuration is optimal for temperature drift compensation because the band gap can be matched with the voltage on the feedback resistors.

The relation between full-scale output current $I_{O(fs)}$ and the R_I (R_Q) is:

$$R_I = \frac{2048 \times V_{GAPOUT}}{82 \times I_{O(fs)}} \Omega$$

The output current can also be adjusted by imposing an external reference voltage to the inverting input pin GAPOUT and disabling the internal band gap with pin GAPD set to HIGH. At a voltage lower than 1.2 V the current can be set at values lower than 20 mA. The input references at pins IVIRES and QVIRES may also be driven by separate reference voltages to adjust independently the two DAC currents.

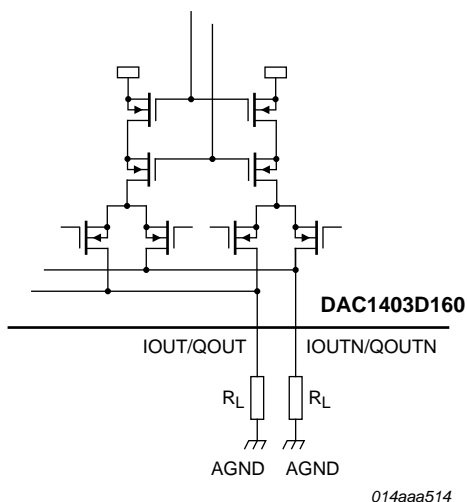

Fig 3. Equivalent analog output circuit

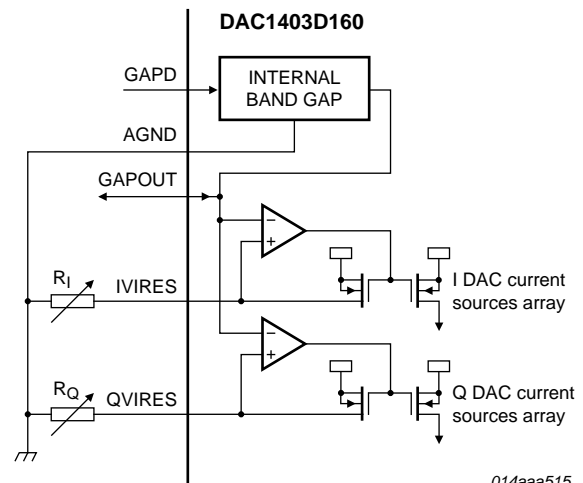

Fig 4. Internal reference configuration

8. Limiting values

Table 3. Limiting values

In accordance with the Absolute Maximum Rating System (IEC 60134).

Symbol	Parameter	Conditions	Min	Max	Unit
V_{CCD}	digital supply voltage	[1]	-0.3	+3.9	V
V_{CCA}	analog supply voltage	[1]	-0.3	+3.9	V
ΔV_{CC}	supply voltage difference	$V_{CCA} - V_{CCD}$	-150	+150	mV
V_I	input voltage	pins Qn and In referenced to DGND	-0.3	$V_{CCD} + 0.3$	V
		pins IVIRES, QVIRES and GAPD referenced to AGND	-0.3	$V_{CCA} + 0.3$	V
		pins CLK and CLKN referenced to AGND	-0.3	$V_{CCA} + 0.3$	V
V_O	output voltage	pins IOUT, IOUTN, QOUT and QOUTN referenced to AGND	-0.3	$V_{CCA} + 0.3$	V
T_{stg}	storage temperature		-55	+150	°C
T_{amb}	ambient temperature		-40	+85	°C
T_j	junction temperature		-	125	°C

[1] All supplies are connected together.

9. Thermal characteristics

Table 4. Thermal characteristics

Symbol	Parameter	Conditions	Typ	Unit
$R_{th(j-a)}$	thermal resistance from junction to ambient	in free air	27.1	K/W
$R_{th(c-a)}$	thermal resistance from case to ambient	in free air	11.8	K/W

10. Characteristics

Table 5. Characteristics

$V_{CCD} = V_{CCA} = 3.0\text{ V to }3.6\text{ V}$; AGND and DGND connected together; $T_{amb} = -40\text{ °C to }+85\text{ °C}$; typical values measured at $V_{CCD} = V_{CCA} = 3.3\text{ V}$, $I_{O(fs)} = 20\text{ mA}$ and $T_{amb} = 25\text{ °C}$; dynamic parameters measured using output schematic given in Figure 10; unless otherwise specified.

Symbol	Parameter	Conditions	Min	Typ	Max	Unit
Supplies						
V_{CCD}	digital supply voltage		3.0	3.3	3.6	V
V_{CCA}	analog supply voltage		3.0	3.3	3.6	V
I_{CCD}	digital supply current		-	55	65	mA
I_{CCA}	analog supply current		-	73	85	mA
P_{tot}	total power dissipation	$f_{clk} = 80\text{ MHz}$; $f_{IOUT} = f_{QOUT} = 5\text{ MHz}$	-	422	540	mW
Clock inputs (CLK and CLKN)						
$V_{I(cm)}$	common-mode input voltage		-	1.65	-	V
$V_{i(dif)(p-p)}$	peak-to-peak differential input voltage		-	1.0	-	V
Analog outputs (IOUT, IOUTN, QOUT and QOUTN)						
$I_{O(fs)}$	full-scale output current	differential outputs	4	-	20	mA
R_o	output resistance		[1] -	150	-	k Ω
C_o	output capacitance		[1] -	3	-	pF
Digital inputs (I0 to I13, Q0 to Q13 and GAPD)						
V_{IL}	LOW-level input voltage		DGND	-	0.3 V_{CCD}	V
V_{IH}	HIGH-level input voltage		0.7 V_{CCD}	-	V_{CCD}	V
I_{IL}	LOW-level input current	$V_{IL} = 0.3\text{ }V_{CCD}$	-	5	-	μA
I_{IH}	HIGH-level input current	$V_{IH} = 0.7\text{ }V_{CCD}$	-	5	-	μA
Reference voltage output (GAPOUT)						
V_{GAPOUT}	voltage on pin GAPOUT		-	1.31	-	V
I_{GAPOUT}	current on pin GAPOUT	external voltage	-	1	-	μA
ΔV_{GAPOUT}	voltage variation on pin GAPOUT		-	± 133	-	ppm/ $^{\circ}\text{C}$
Clock timing inputs (CLK and CLKN)						
f_{clk}	clock frequency		-	-	80	MHz
$t_{w(clk)H}$	HIGH clock pulse width		5	-	-	ns
$t_{w(clk)L}$	LOW clock pulse width		5	-	-	ns
Input timing (I0 to I13 and Q0 to Q13); see Figure 5						
$t_{h(i)}$	input hold time		1.1	-	3.4	ns
$t_{su(i)}$	input set-up time		-1.5	-	+0.7	ns
Output timing (IOUT, IOUTN, QOUT, QOutN)						
t_s	settling time	$t_o = \pm 0.5\text{ LSB}$	[1] -	43	-	ns

Table 5. Characteristics ...continued

$V_{CCD} = V_{CCA} = 3.0\text{ V to }3.6\text{ V}$; AGND and DGND connected together; $T_{amb} = -40\text{ }^{\circ}\text{C to }+85\text{ }^{\circ}\text{C}$; typical values measured at $V_{CCD} = V_{CCA} = 3.3\text{ V}$, $I_{O(fs)} = 20\text{ mA}$ and $T_{amb} = 25\text{ }^{\circ}\text{C}$; dynamic parameters measured using output schematic given in Figure 10; unless otherwise specified.

Symbol	Parameter	Conditions	Min	Typ	Max	Unit
Digital filter specification (FIR); order N = 42; see Figure 6 and 7 and Table 7						
f_{data}	data rate		-	-	80	MHz
$\alpha_{ripple(pb)}$	pass-band ripple	f_{data}/f_{clk} ; 0.005 dB attenuation	-	0.405	-	
B_p	power bandwidth	f_{data}/f_{clk} ; 3 dB attenuation	-	0.479	-	
α_{stpb}	stop-band attenuation	$f_{data}/f_{clk} = 0.6$ to 1	-	69	-	dB
$t_{d(grp)}$	group delay time		-	$11T_{CLK}$	-	ns
Analog signal processing						
Linearity						
INL	integral non-linearity		-	± 2.9	-	LSB
DNL	differential non-linearity		-	± 1.5	-	LSB
$I_{n(o)}$	output noise current		-	120	-	pA/ $\sqrt{\text{Hz}}$
E_{offset}	offset error	relative to full-scale	-	-0.3	-	%
E_G	gain error	relative to full-scale	-5.4	-	+5.4	%
ΔG_{IQ}	IQ gain mismatch	between I and Q, relative to full-scale	-	± 0.2	-	%
Spurious free dynamic range						
SFDR	spurious free dynamic range	$f_{clk} = 80\text{ MHz}$; BW = Nyquist				
		$f_o = 2.5\text{ MHz}$ at 0 dBFS	-	80	-	dBc
		$f_o = 5\text{ MHz}$ at 0 dBFS	-	72	-	dBc
		$f_o = 13\text{ MHz}$ at 0 dBFS	-	64	-	dBc
Harmonics						
α_{2H}	second harmonic level	$f_o = 5\text{ MHz}$	-	73	-	dBc
		$f_o = 13\text{ MHz}$	-	65	-	dBc
α_{3H}	third harmonic level	$f_o = 5\text{ MHz}$	-	88	-	dBc
		$f_o = 13\text{ MHz}$	-	86	-	dBc
Two-tone intermodulation						
IMD2	second-order intermodulation distortion	$f_{clk} = 80\text{ MHz}$; $f_o 1 = 10\text{ MHz}$; $f_o 2 = 12\text{ MHz}$; BW = Nyquist	-	65	-	dBc
IMD3	third-order intermodulation distortion	$f_{clk} = 80\text{ MHz}$; $f_o 1 = 10\text{ MHz}$; $f_o 2 = 12\text{ MHz}$	-	84	-	dBc
THD	total harmonic distortion	$f_{clk} = 80\text{ MHz}$; BW = Nyquist ($T_{amb} = 25\text{ }^{\circ}\text{C}$)				
		$f_o = 2.5\text{ MHz}$	-	75	-	dBc
		$f_o = 5\text{ MHz}$	68	71	-	dBc
NSD	noise spectral density	$f_{clk} = 80\text{ MHz}$				
		$f_o = 2.5\text{ MHz}$	-	-155	-	dBm/Hz
		$f_o = 5\text{ MHz}$	-	-155	-	dBm/Hz
		$f_o = 19\text{ MHz}$	-	-153	-	dBm/Hz

Table 5. Characteristics ...continued

$V_{CCD} = V_{CCA} = 3.0\text{ V to }3.6\text{ V}$; AGND and DGND connected together; $T_{amb} = -40\text{ }^{\circ}\text{C to }+85\text{ }^{\circ}\text{C}$; typical values measured at $V_{CCD} = V_{CCA} = 3.3\text{ V}$, $I_{O(fs)} = 20\text{ mA}$ and $T_{amb} = 25\text{ }^{\circ}\text{C}$; dynamic parameters measured using output schematic given in Figure 10; unless otherwise specified.

Symbol	Parameter	Conditions	Min	Typ	Max	Unit
Signal-to-noise ratio						
S/N	signal-to-noise ratio	$f_{clk} = 80\text{ MHz}$; BW = Nyquist				
		$f_o = 2.5\text{ MHz}$	-	80	-	dBc
		$f_o = 5\text{ MHz}$	70	80	-	dBc
		$f_o = 19\text{ MHz}$	-	78	-	dBc
ACPR	adjacent channel power ratio	baseband; 5 MHz channel spacing; BW = 3.84 MHz				
		$f_o = 2.5\text{ MHz}$	-	69	-	dBc
		$f_o = 20\text{ MHz}$	-	71	-	dBc

[1] Guaranteed by design.

Table 6. Band gap

Band gap disable (GAPD)	Band gap input/output (GAPOUT)	Internal band gap
LOW	output ($V_{GAPOUT} = 1.2\text{ V}$)	enable
HIGH	input	disable

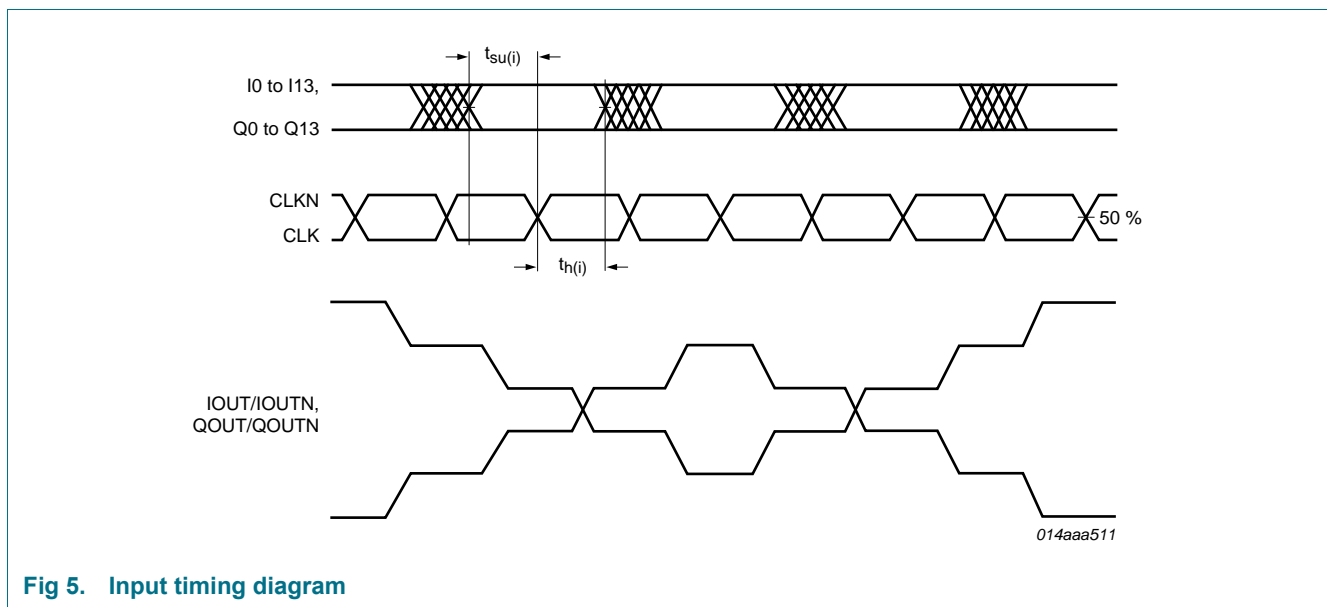

Fig 5. Input timing diagram

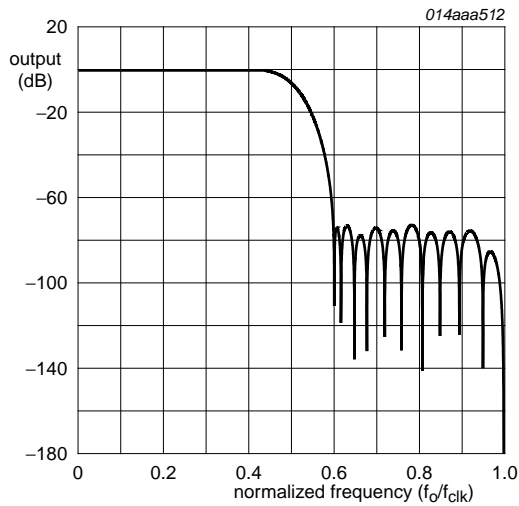

Fig 6. FIR filter frequency response

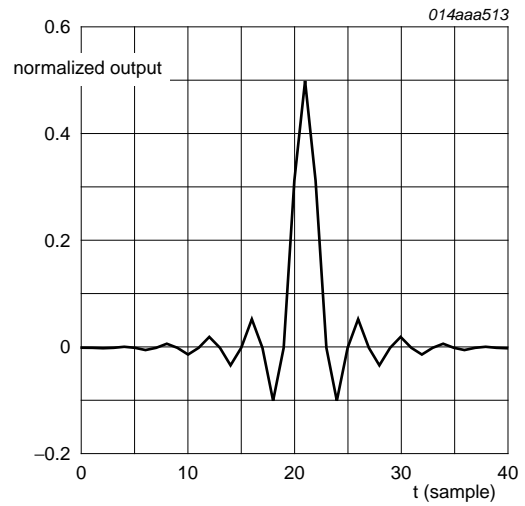

Fig 7. FIR filter impulse response

Table 7. Interpolation FIR filter coefficient

Coefficient	Coefficient	Value
H(1)	H(43)	10
H(2)	H(42)	0
H(3)	H(41)	-31
H(4)	H(40)	0
H(5)	H(39)	69
H(6)	H(38)	0
H(7)	H(37)	-138
H(8)	H(36)	0
H(9)	H(35)	248
H(10)	H(34)	0
H(11)	H(33)	-419
H(12)	H(32)	0
H(13)	H(31)	678
H(14)	H(30)	0
H(15)	H(29)	-1083
H(16)	H(28)	0
H(17)	H(27)	1776
H(18)	H(26)	0
H(19)	H(25)	-3282
H(20)	H(24)	0
H(21)	H(23)	10364
H(22)	-	16384

11. Application information

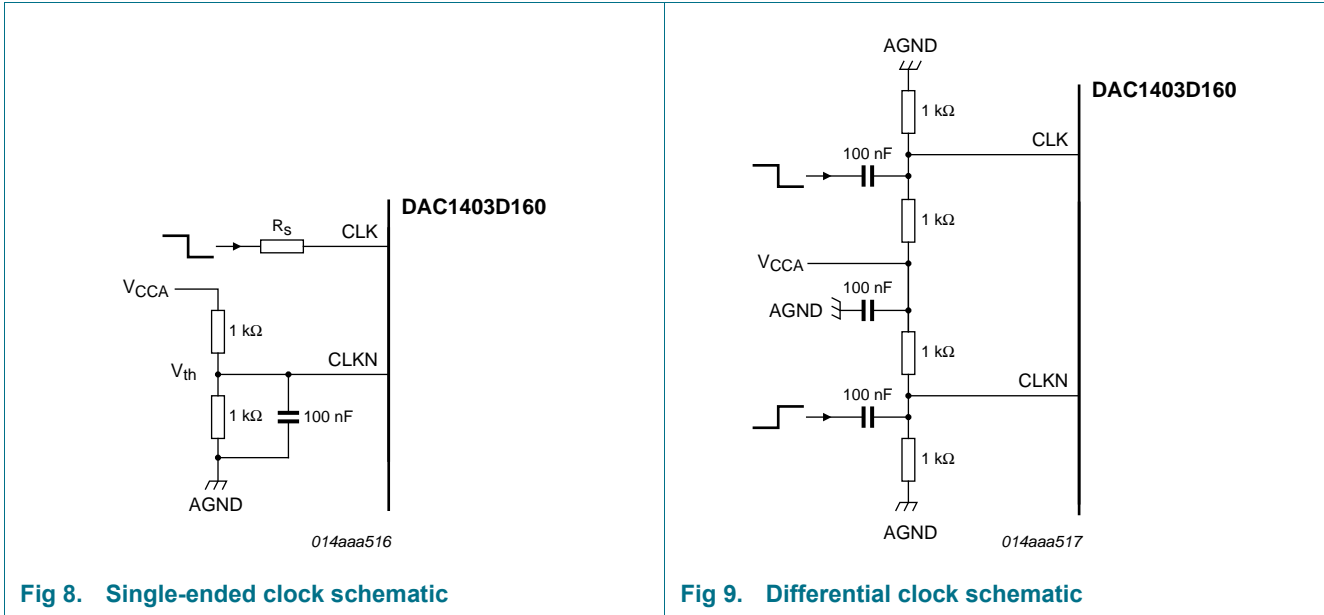

Fig 8. Single-ended clock schematic

Fig 9. Differential clock schematic

11.1 Alternative parts

The following alternative parts are also available:

Table 8. Alternative parts

Type number	Description		Sampling frequency
DAC1203D160	Dual 12 bits DAC, with 2 × interpolating	[1]	160 MHz
DAC1003D160	Dual 10 bits DAC, with 2 × interpolating	[1]	160 MHz

[1] Pin to pin compatible

12. Package outline

HTQFP80: plastic thermal enhanced thin quad flat package; 80 leads; body 12 x 12 x 1 mm; exposed die pad SOT841-1

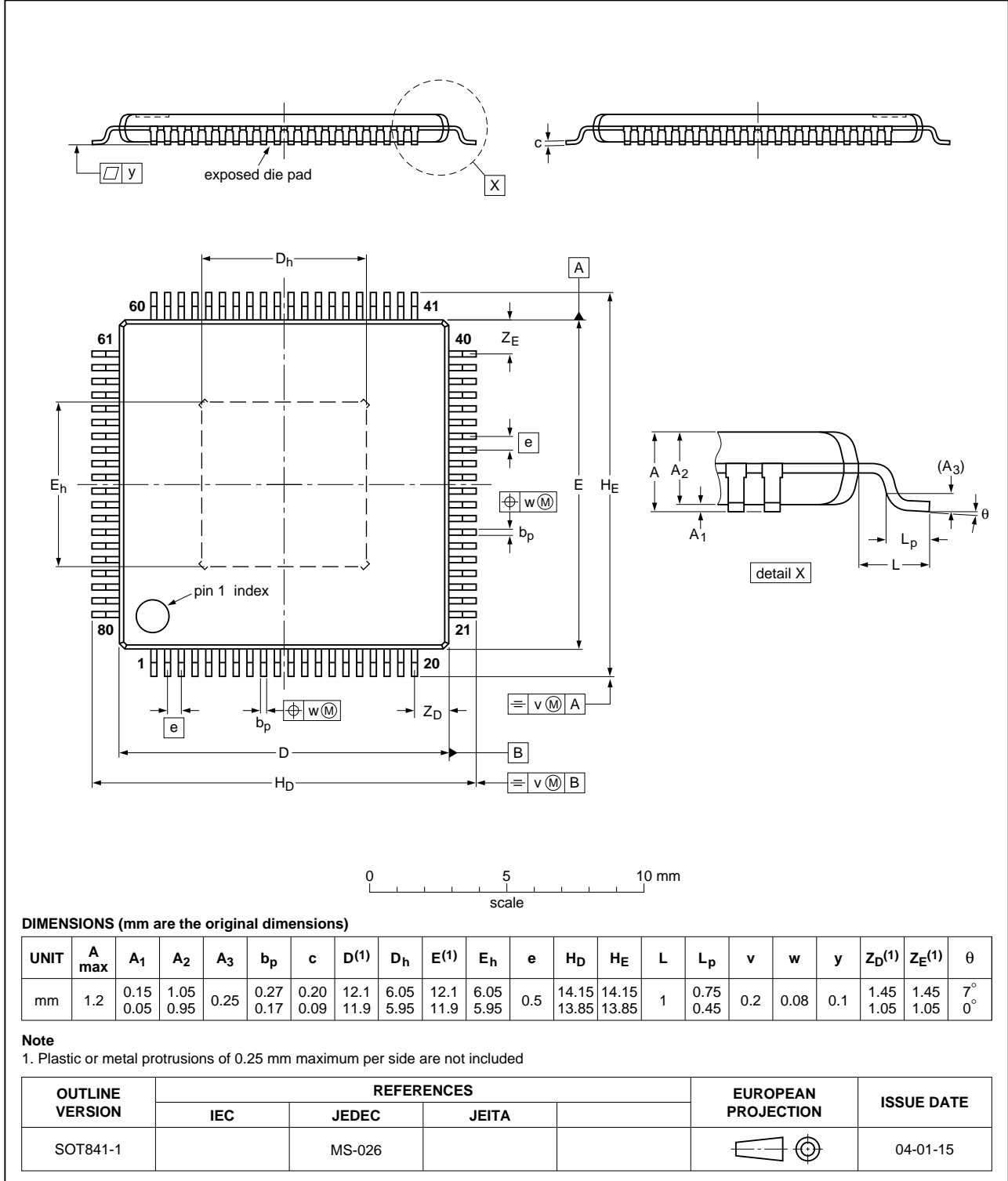

Fig 11. Package outline SOT841-1 (HTQFP80)

13. Abbreviations

Table 9. Abbreviations

Acronym	Description
BW	BandWidth
FIR	Finite Impulse Response
IF	Intermediate Frequency
LSB	Least Significant Bit
MSB	Most Significant Bit
PLL	Phase-Locked Loop
PMOS	Positive-Metal Oxide Semiconductor

14. Glossary

14.1 Static parameters

DNL — Differential Non-Linearity. The difference between the ideal and the measured output value between successive DAC codes.

INL — Integral Non-Linearity. The deviation of the transfer function from a best-fit straight line (linear regression computation).

14.2 Dynamic parameters

IMD2 — Second-order intermodulation distortion. From a dual-tone digital input sine wave (these two frequencies are close together), the intermodulation distortion product IMD2 is the ratio of the RMS value of either tone and the RMS value of the worst 2nd-order intermodulation product.

IMD3 — Third-order intermodulation distortion. From a dual-tone digital input sine wave (these two frequencies are close together), the intermodulation distortion product IMD3 is the ratio of the RMS value of either tone and the RMS value of the worst 3rd-order intermodulation product.

S/N — Signal-to-Noise ratio. The ratio of the RMS value of the reconstructed output sine wave to the RMS value of the noise excluding the harmonics and the DC component.

THD — Total Harmonic Distortion. The ratio of the RMS value of the harmonics of the output frequency to the RMS value of the output sine wave. Usually, the calculation of THD is done on the first 5 harmonics.

SFDR — Spurious-Free Dynamic Range. The ratio of the RMS value of the reconstructed output sine wave and the RMS value of the largest spurious (harmonic and non-harmonic, excluding DC component) observed in the frequency domain.

15. Revision history

Table 10. Revision history

Document ID	Release date	Data sheet status	Change notice	Supersedes
DAC1403D160_3	20120702	Product data sheet	-	DAC1403D160_2
DAC1403D160_2	20080814	Product data sheet	-	DAC1403D160_1
Modifications:	<ul style="list-style-type: none">• Corrections made to row Q0 in Table 2.• Added condition & correction of value to t_s in Table 5.• Additional definition in Section 14.			
DAC1403D160_1	20080616	Product data sheet	-	-

16. Contact information

For more information or sales office addresses, please visit: <http://www.idt.com>

17. Contents

1	General description	1	10	Characteristics	8
2	Features	1	11	Application information	12
3	Applications	1	11.1	Alternative parts	14
4	Ordering information	2	12	Package outline	15
5	Block diagram	2	13	Abbreviations	16
6	Pinning information	3	14	Glossary	16
6.1	Pinning	3	14.1	Static parameters	16
6.2	Pin description	3	14.2	Dynamic parameters	16
7	Functional description	6	15	Revision history	17
8	Limiting values	7	16	Contact information	17
9	Thermal characteristics	7	17	Contents	18