

ADC0801S040

Single 8 bits ADC, up to 40 MHz

Rev. 03 — 2 July 2012

Product data sheet

1. General description

The ADC0801S040 is an 8-bit universal analog-to-digital converter (ADC) for video and general purpose applications. It converts the analog input signal from 2.7 V to 5.5 V into 8-bit binary-coded digital words at a maximum sampling rate of 40 MHz. All digital inputs and outputs are CMOS/Transistor-Transistor Logic (TTL) compatible. A sleep mode allows reduction of the device power consumption to 4 mW.

2. Features

- 8-bit resolution
- Operation between 2.7 V and 5.5 V
- Sampling rate up to 40 MHz
- DC sampling allowed
- High signal-to-noise ratio over a large analog input frequency range (7.3 effective bits at 4.43 MHz full-scale input at $f_{\text{clk}} = 40$ MHz)
- CMOS/TTL compatible digital inputs and outputs
- External reference voltage regulator
- Power dissipation only 30 mW (typical value)
- Low analog input capacitance, no buffer amplifier required
- Sleep mode (4 mW)
- No sample-and-hold circuit required

3. Applications

- Video data digitizing
- Camera
- Camcorder
- Radio communication
- Car alarm system



4. Quick reference data

Table 1. Quick reference data

$V_{DDA} = V5$ to $V6 = 3.3$ V; $V_{DDD} = V3$ to $V4 = 3.3$ V; $V_{DDO} = V20$ to $V11 = 3.3$ V; V_{SSA} , V_{SSD} and V_{SSO} shorted together; $V_{i(a)(p-p)} = 1.84$ V; $C_L = 20$ pF; $T_{amb} = 0$ °C to 70 °C; typical values measured at $T_{amb} = 25$ °C unless otherwise specified.

Symbol	Parameter	Conditions	Min	Typ	Max	Unit
V_{DDA}	analog supply voltage		2.7	3.3	5.5	V
V_{DDD}	digital supply voltage		2.7	3.3	5.5	V
V_{DDO}	output supply voltage		2.5	3.3	5.5	V
ΔV_{DD}	supply voltage difference	$V_{DDA} - V_{DDD}$	-0.2	-	+0.2	V
		$V_{DDD} - V_{DDO}$	-0.2	-	+2.25	V
I_{DDA}	analog supply current		-	4	6	mA
I_{DDD}	digital supply current		-	5	8	mA
I_{DDO}	output supply current	$f_{clk} = 40$ MHz; ramp input; $C_L = 20$ pF	-	1	2	mA
INL	integral non-linearity	ramp input; see Figure 6	-	± 0.5	± 0.75	LSB
DNL	differential non-linearity	ramp input; see Figure 7	-	± 0.25	± 0.5	LSB
$f_{clk(max)}$	maximum clock frequency		40	-	-	MHz
P_{tot}	total power dissipation	$V_{DDA} = V_{DDD} = V_{DDO} = 3.3$ V	-	30	53	mW

5. Ordering information

Table 2. Ordering information

Type number	Package		Version
	Name	Description	
ADC0801S040TS	SSOP20	plastic shrink small outline package; 20 leads; body width 4.4 mm	SOT266-1

6. Block diagram

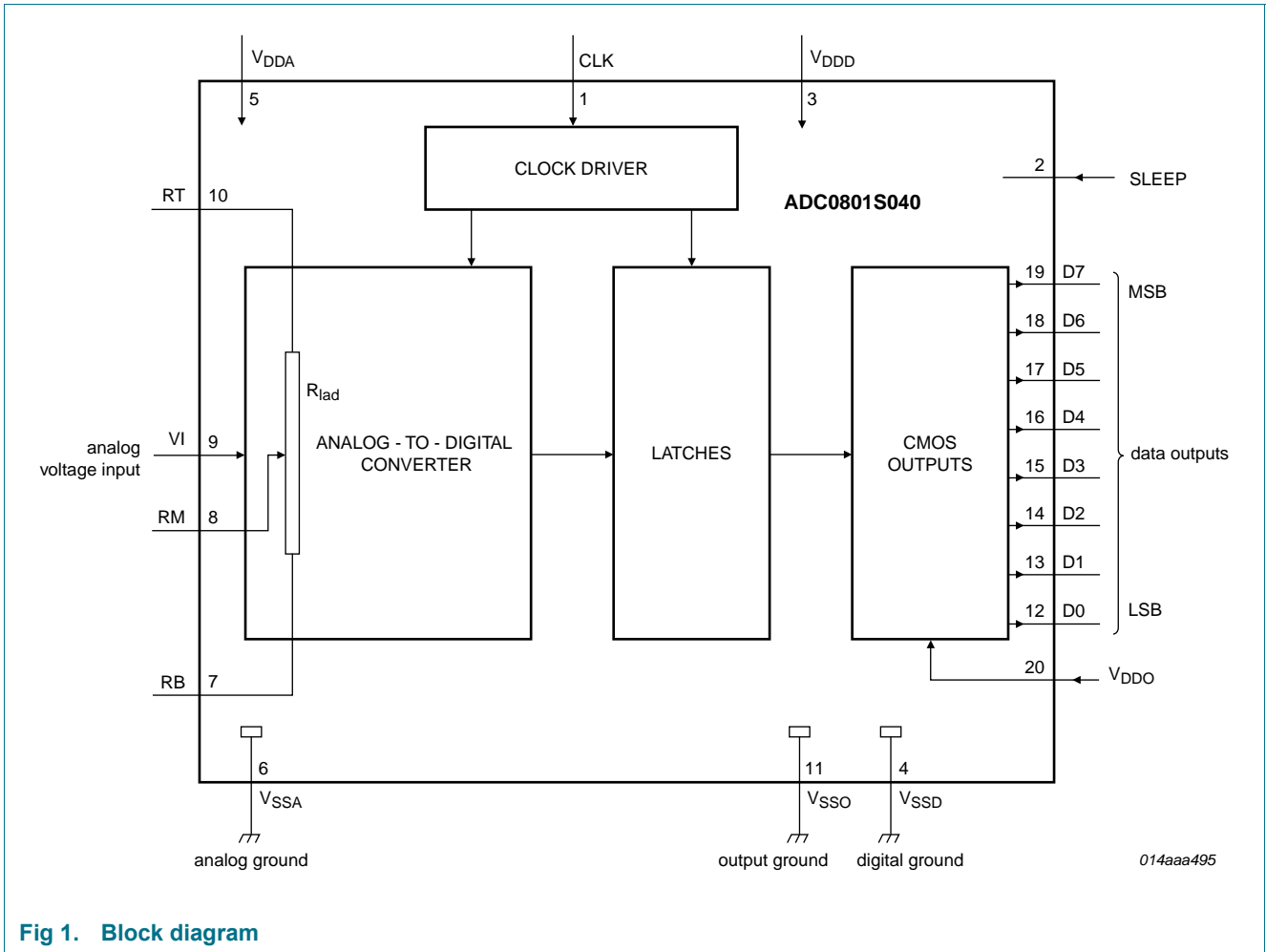
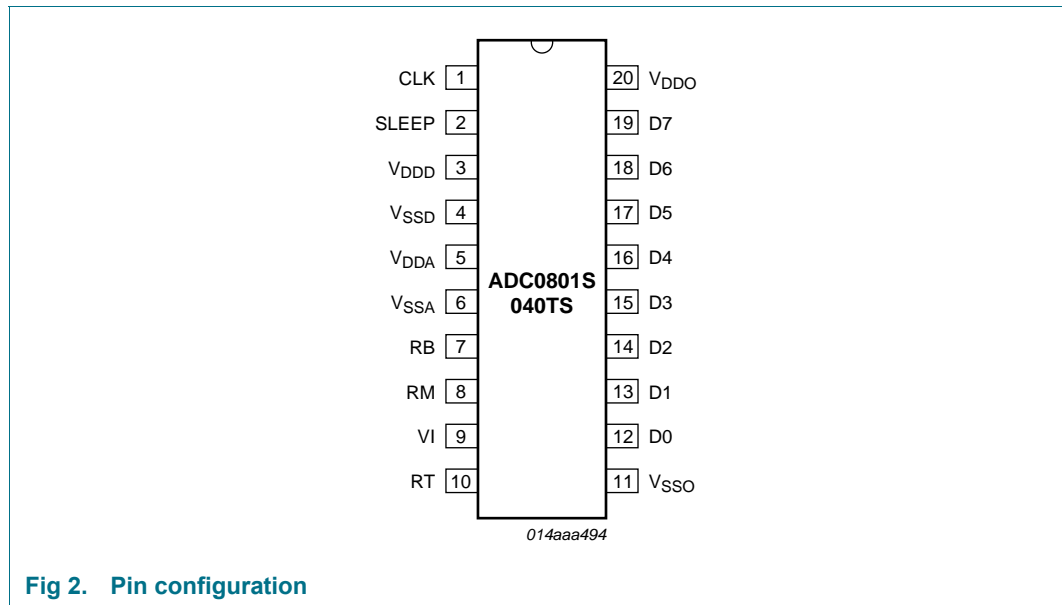

Fig 1. Block diagram

7. Pinning information

7.1 Pinning



7.2 Pin description

Table 3. Pin description

Symbol	Pin	Description
CLK	1	clock input
SLEEP	2	sleep mode input
V _{DDD}	3	digital supply voltage (2.7 V to 5.5 V)
V _{SSD}	4	digital ground
V _{DDA}	5	analog supply voltage (2.7 V to 5.5 V)
V _{SSA}	6	analog ground
RB	7	reference voltage BOTTOM input
RM	8	reference voltage MIDDLE
VI	9	analog input voltage
RT	10	reference voltage TOP input
V _{SSO}	11	output stage ground
D0	12	data output; bit 0 (Least Significant Bit (LSB))
D1	13	data output; bit 1
D2	14	data output; bit 2
D3	15	data output; bit 3
D4	16	data output; bit 4
D5	17	data output; bit 5

Table 3. Pin description ...continued

Symbol	Pin	Description
D6	18	data output; bit 6
D7	19	data output; bit 7 (Most Significant Bit (MSB))
V _{DDO}	20	positive supply voltage for output stage (2.7 V to 5.5 V)

8. Limiting values

Table 4. Limiting values

In accordance with the Absolute Maximum Rating System (IEC 60134).

Symbol	Parameter	Conditions	Min	Max	Unit
V _{DDA}	analog supply voltage		[1] -0.3	+7.0	V
V _{DDD}	digital supply voltage		[1] -0.3	+7.0	V
V _{DDO}	output supply voltage		[1] -0.3	+7.0	V
ΔV_{DD}	supply voltage difference	V _{DDA} - V _{DDD} ; V _{DDD} - V _{DDO} ; V _{DDA} - V _{DDO}	-0.1	+4.0	V
V _I	input voltage	referenced to V _{SSA}	-0.3	+7.0	V
V _{i(ck)(p-p)}	peak-to-peak clock input voltage	referenced to V _{SSD}	-	V _{DDD}	V
I _O	output current		-	10	mA
T _{stg}	storage temperature		-55	+150	°C
T _{amb}	ambient temperature		-20	+75	°C
T _j	junction temperature		-	150	°C

[1] The supply voltages V_{DDA}, V_{DDD} and V_{DDO} may have any value between -0.3 V and +7.0 V provided that the supply voltage ΔV_{DD} remains as indicated.

9. Thermal characteristics

Table 5. Thermal characteristics

Symbol	Parameter	Condition	Value	Unit
R _{th(j-a)}	thermal resistance from junction to ambient	in free air	120	K/W

10. Characteristics

Table 6. Characteristics

V_{DDA} = V5 to V6 = 3.3 V; V_{DDD} = V3 to V4 = 3.3 V; V_{DDO} = V20 to V11 = 3.3 V; V_{SSA}, V_{SSD} and V_{SSO} shorted together; V_{i(a)(p-p)} = 1.84 V; C_L = 20 pF; T_{amb} = 0 °C to 70 °C; typical values measured at T_{amb} = 25 °C unless otherwise specified.

Symbol	Parameter	Conditions	Min	Typ	Max	Unit
Supplies						
V _{DDA}	analog supply voltage		2.7	3.3	5.5	V
V _{DDD}	digital supply voltage		2.7	3.3	5.5	V
V _{DDO}	output supply voltage		2.5	3.3	5.5	V

Table 6. Characteristics ...continued

$V_{DDA} = V5$ to $V6 = 3.3$ V; $V_{DDD} = V3$ to $V4 = 3.3$ V; $V_{DDO} = V20$ to $V11 = 3.3$ V; V_{SSA} , V_{SSD} and V_{SSO} shorted together; $V_{I(a)(p-p)} = 1.84$ V; $C_L = 20$ pF; $T_{amb} = 0$ °C to 70 °C; typical values measured at $T_{amb} = 25$ °C unless otherwise specified.

Symbol	Parameter	Conditions	Min	Typ	Max	Unit
ΔV_{DD}	supply voltage difference	$V_{DDA} - V_{DDD}$	-0.2	-	+0.2	V
		$V_{DDD} - V_{DDO}$	-0.2	-	+2.25	V
I_{DDA}	analog supply current		-	4	6	mA
I_{DDD}	digital supply current		-	5	8	mA
I_{DDO}	output supply current	$f_{clk} = 40$ MHz; ramp input; $C_L = 20$ pF	-	1	2	mA
P_{tot}	total power dissipation	$V_{DDA} = V_{DDD} = V_{DDO} = 3.3$ V	-	30	53	mW

Inputs

Clock input CLK (Referenced to V_{SSD})^[1]

V_{IL}	LOW-level input voltage		0	-	$0.3 V_{DDD}$	V
V_{IH}	HIGH-level input voltage	$V_{DDD} \leq 3.6$ V	$0.6 V_{DDD}$	-	V_{DDD}	V
		$V_{DDD} > 3.6$ V	$0.7 V_{DDD}$	-	V_{DDD}	V
I_{IL}	LOW-level input current	$V_{clk} = 0.3 V_{DDD}$	-1	0	+1	μA
I_{IH}	HIGH-level input current	$V_{clk} = 0.7 V_{DDD}$	-	-	5	μA
Z_i	input impedance	$f_{clk} = 40$ MHz	-	4	-	kΩ
C_i	input capacitance	$f_{clk} = 40$ MHz	-	3	-	pF

Input SLEEP (Referenced to V_{SSD}); see Table 8

V_{IL}	LOW-level input voltage		0	-	$0.3 V_{DDD}$	V
V_{IH}	HIGH-level input voltage	$V_{DDD} \leq 3.6$ V	$0.6 V_{DDD}$	-	V_{DDD}	V
		$V_{DDD} > 3.6$ V	$0.7 V_{DDD}$	-	V_{DDD}	V
I_{IL}	LOW-level input current	$V_{IL} = 0.3 V_{DDD}$	-1	-	-	μA
I_{IH}	HIGH-level input current	$V_{IH} = 0.7 V_{DDD}$	-	-	+1	μA

Analog input VI (Referenced to V_{SSA})

I_{IL}	LOW-level input current	$V_I = V_{RB}$	-	0	-	μA
I_{IH}	HIGH-level input current	$V_I = V_{RT}$	-	9	-	μA
Z_i	input impedance	$f_i = 1$ MHz	-	20	-	kΩ
C_i	input capacitance	$f_i = 1$ MHz	-	2	-	pF

Reference voltages for the resistor ladder; see Table 7

V_{RB}	voltage on pin RB		1.1	1.2	-	V
V_{RT}	voltage on pin RT	$V_{RT} \leq V_{DDA}$	2.7	3.3	V_{DDA}	V
$V_{ref(dif)}$	differential reference voltage	$V_{RT} - V_{RB}$	1.5	2.1	2.7	V
I_{ref}	reference current		-	0.95	-	mA
R_{lad}	ladder resistance		-	2.2	-	kΩ
TC_{Rlad}	ladder resistor temperature coefficient		-	4092	-	mΩ/K
V_{offset}	offset voltage	BOTTOM	[2] -	170	-	mV
		TOP	[2] -	170	-	mV
$V_{I(a)(p-p)}$	peak-to-peak analog input voltage		[3] 1.4	1.76	2.4	V

Table 6. Characteristics ...continued

$V_{DDA} = V5$ to $V6 = 3.3$ V; $V_{DDD} = V3$ to $V4 = 3.3$ V; $V_{DDO} = V20$ to $V11 = 3.3$ V; V_{SSA} , V_{SSD} and V_{SSO} shorted together; $V_{i(a)(p-p)} = 1.84$ V; $C_L = 20$ pF; $T_{amb} = 0$ °C to 70 °C; typical values measured at $T_{amb} = 25$ °C unless otherwise specified.

Symbol	Parameter	Conditions	Min	Typ	Max	Unit
Digital outputs D7 to D0 and IR (Referenced to V_{SSD})						
V_{OL}	LOW-level output voltage	$I_O = 1$ mA	0	-	0.5	V
V_{OH}	HIGH-level output voltage	$I_O = -1$ mA	$V_{DDO} - 0.5$	-	V_{DDO}	V
I_{OZ}	OFF-state output current	0.4 V < V_O < V_{DDO}	-20	-	+20	μA
Clock input CLK; see Figure 4^[1]						
$f_{clk(max)}$	maximum clock frequency		40	-	-	MHz
$t_{w(ck)H}$	HIGH clock pulse width		9	-	-	ns
$t_{w(ck)L}$	LOW clock pulse width		9	-	-	ns
Analog signal processing ($f_{clk} = 40$ MHz)						
Linearity						
INL	integral non-linearity	ramp input; see Figure 6	-	±0.5	±0.75	LSB
DNL	differential non-linearity	ramp input; see Figure 7	-	±0.25	±0.5	LSB
Bandwidth						
B	bandwidth	full-scale sine wave	^[4] -	10	-	MHz
		75 % full-scale sine wave	-	13	-	MHz
		50 % full-scale sine wave	-	20	-	MHz
		small signal at mid scale; $V_i = \pm 10$ LSB at code 128	-	350	-	MHz
Input set response; see Figure 8^[5]						
$t_{s(LH)}$	LOW to HIGH settling time	full-scale square wave	-	3	5	ns
$t_{s(HL)}$	HIGH to LOW settling time	full-scale square wave	-	3	5	ns
Harmonics; see Figure 9^[6]						
THD	total harmonic distortion	$f_i = 4.43$ MHz	-	-50	-	dB
Signal-to-Noise ratio; see Figure 9^[6]						
S/N	signal-to-noise ratio	without harmonics; $f_i = 4.43$ MHz	-	47	-	dB
Effective bits; see Figure 9^[6]						
ENOB	effective number of bits	$f_i = 300$ MHz	-	7.8	-	bits
		$f_i = 4.43$ MHz	-	7.3	-	bits
Differential gain^[7]						
G_{dif}	differential gain	PAL modulated ramp	-	1.5	-	%

Table 6. Characteristics ...continued

$V_{DDA} = V5$ to $V6 = 3.3$ V; $V_{DDD} = V3$ to $V4 = 3.3$ V; $V_{DDO} = V20$ to $V11 = 3.3$ V; V_{SSA} , V_{SSD} and V_{SSO} shorted together; $V_{I(a)(p-p)} = 1.84$ V; $C_L = 20$ pF; $T_{amb} = 0$ °C to 70 °C; typical values measured at $T_{amb} = 25$ °C unless otherwise specified.

Symbol	Parameter	Conditions	Min	Typ	Max	Unit
Differential phase^[7]						
ϕ_{dif}	differential phase	PAL modulated ramp	-	0.25	-	deg
Timing ($f_{clk} = 40$ MHz; $C_L = 20$ pF); see Figure 4^[8]						
$t_{d(s)}$	sampling delay time		-	-	5	ns
$t_{h(o)}$	output hold time		5	-	-	ns
$t_{d(o)}$	output delay time	$V_{DDO} = 4.75$ V	8	12	15	ns
		$V_{DDO} = 3.15$ V	8	17	20	ns
		$V_{DDO} = 2.7$ V	8	18	21	ns
3-state output delay times; see Figure 5						
t_{dHZ}	active HIGH to float delay time		-	14	18	ns
t_{dZL}	float to active LOW delay time		-	16	20	ns
t_{dZH}	float to active HIGH delay time		-	16	20	ns
t_{dLZ}	active LOW to float delay time		-	14	18	ns

- [1] In addition to a good layout of the digital and analog ground, it is recommended that the rise and fall times of the clock must not be less than 1 ns.
- [2] Analog input voltages producing code 0 up to and including code 255:
 - a) $V_{offset\ BOTTOM}$ is the difference between the analog input which produces data equal to 00 and the reference voltage on pin RB (V_{RB}) at $T_{amb} = 25$ °C.
 - b) $V_{offset\ TOP}$ is the difference between the reference voltage on pin RT (V_{RT}) and the analog input which produces data outputs equal to code 255 at $T_{amb} = 25$ °C.
- [3] To ensure the optimum linearity performance of such a converter architecture the lower and upper extremities of the converter reference resistor ladder are connected to pins RB and RT via offset resistors R_{OB} and R_{OT} as shown in Figure 3.
 - a) The current flowing into the resistor ladder is $I = \frac{V_{RT} - V_{RB}}{R_{OB} + R_L + R_{OT}}$ and the full-scale input range at the converter, to cover code 0 to 255 is $V_I = R_L \times I_L = \frac{R_L}{R_{OB} + R_L + R_{OT}} \times (V_{RT} + V_{RB}) = 0.838 \times (V_{RT} - V_{RB})$
 - b) Since R_L , R_{OB} and R_{OT} have similar behavior with respect to process and temperature variation, the ratio $\frac{R_L}{R_{OB} + R_L + R_{OT}}$ will be kept reasonably constant from device to device. Consequently variation of the output codes at a given input voltage depends mainly on the difference $V_{RT} - V_{RB}$ and its variation with temperature and supply voltage. When several ADCs are connected in parallel and fed with the same reference source, the matching between each of them is optimized.
- [4] The analog bandwidth is defined as the maximum input sine wave frequency which can be applied to the device. No glitches greater than 2 LSB, nor any significant attenuation is observed in the reconstructed signal.
- [5] The analog input settling time is the minimum time required for the input signal to be stabilized after a sharp full-scale input (square wave signal) in order to sample the signal and obtain correct output data.
- [6] Effective bits are obtained via a Fast Fourier Transform (FFT) treatment taking 8000 acquisition points per equivalent fundamental period. The calculation takes into account all harmonics and noise up to half of the clock frequency (Nyquist frequency). Conversion to signal-to-noise ratio: $S/N = ENOB \times 6.02 + 1.76$ dB.
- [7] Measurement carried out using video analyzer VM700A, where video analog signal is reconstructed through a DAC.
- [8] Output data acquisition: the output data is available after the maximum delay time of $t_{d(o)}$.

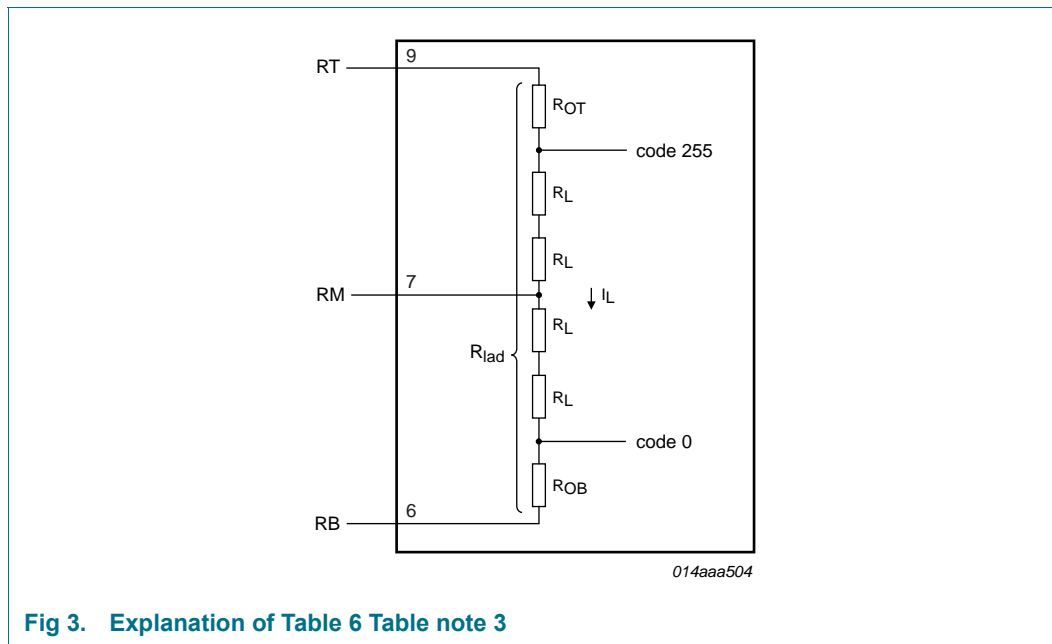

Fig 3. Explanation of Table 6 Table note 3

11. Additional information relating to Table 6

Table 7. Output coding and input voltage (typical values; referenced to V_{SSA})

Code	$V_{i(a)(p-p)}$ (V)	Binary outputs D7 to D0
Underflow	< 1.37	00 0000 00
0	1.37	00 0000 00
1	-	00 0000 01
↓	-	↓
254	-	11 11 11 10
255	3.13	11 11 11 11
Overflow	> 3.13	11 11 11 11

Table 8. Mode selection

SLEEP	D7 to D0	$I_{DDA} + I_{DDD}$ (typ)
1	high impedance	1.2 mA
0	active	9 mA

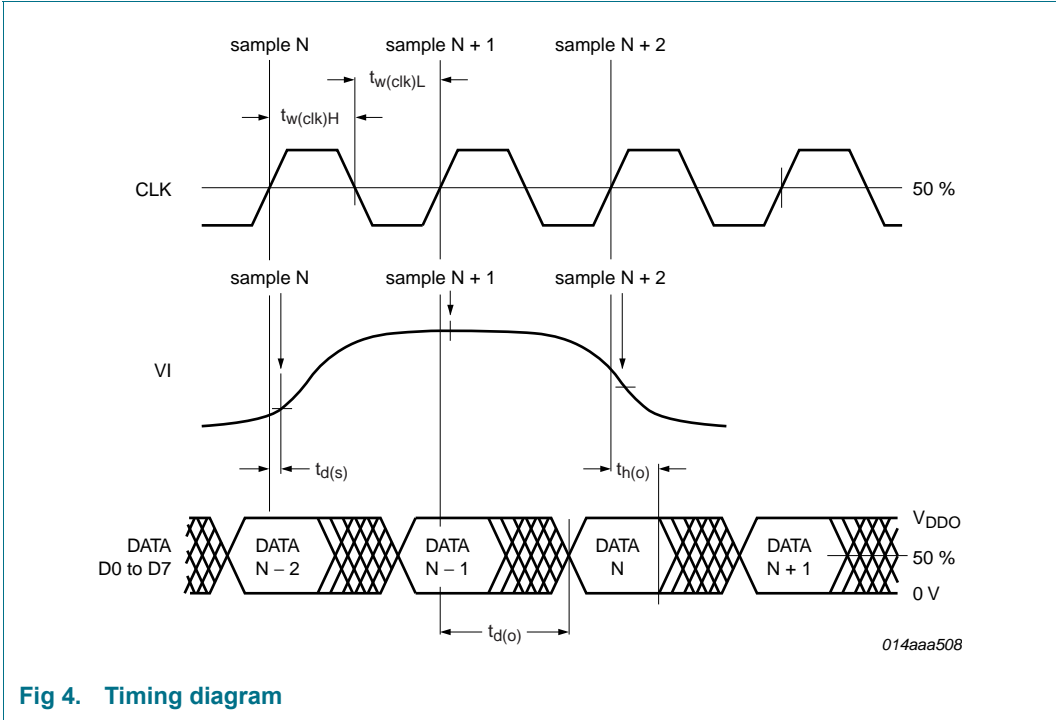
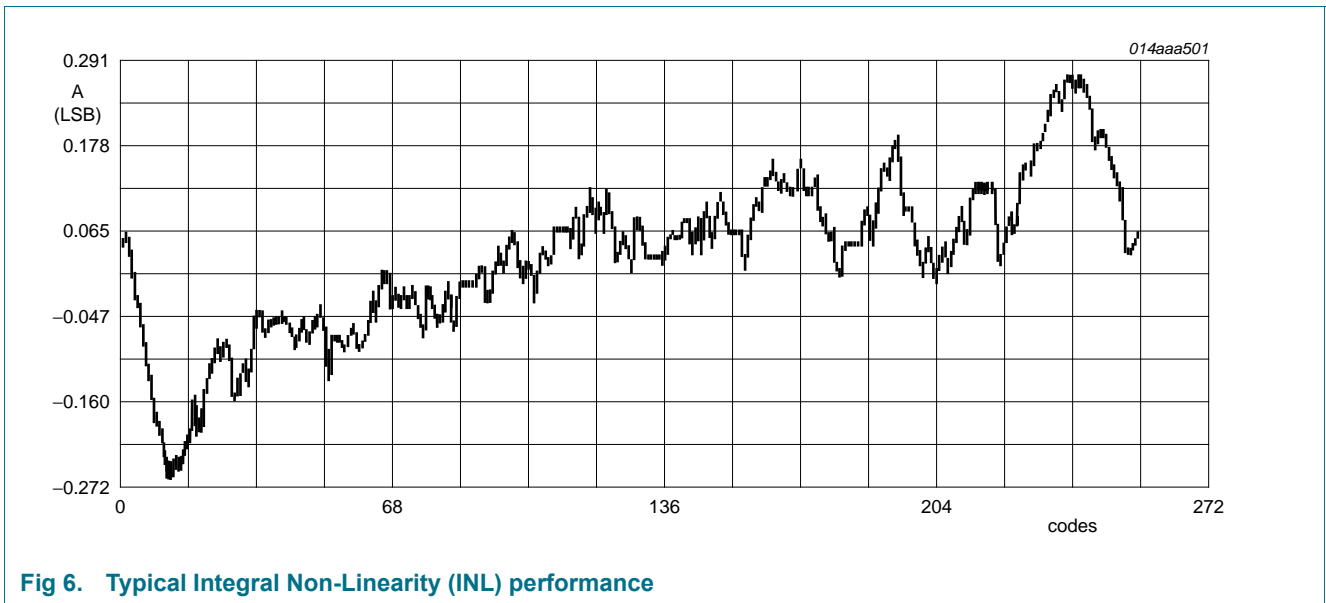
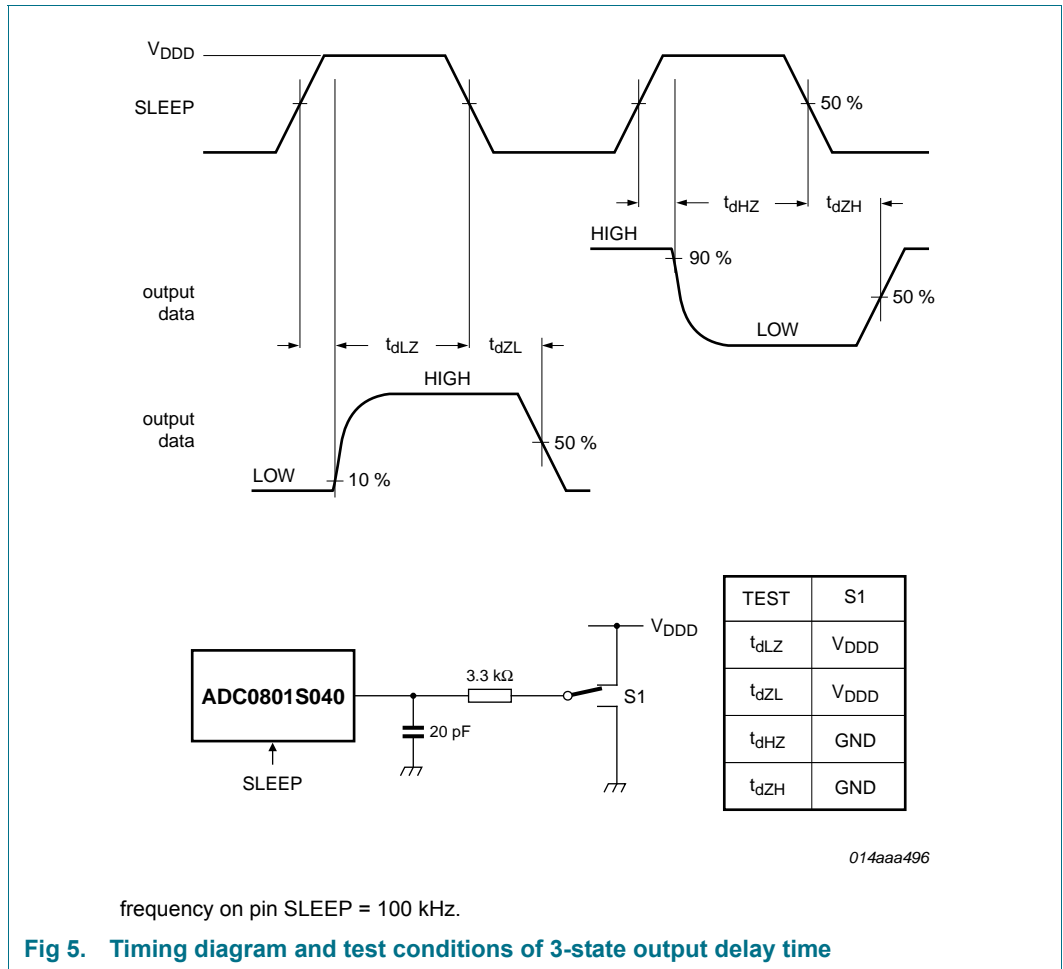

Fig 4. Timing diagram



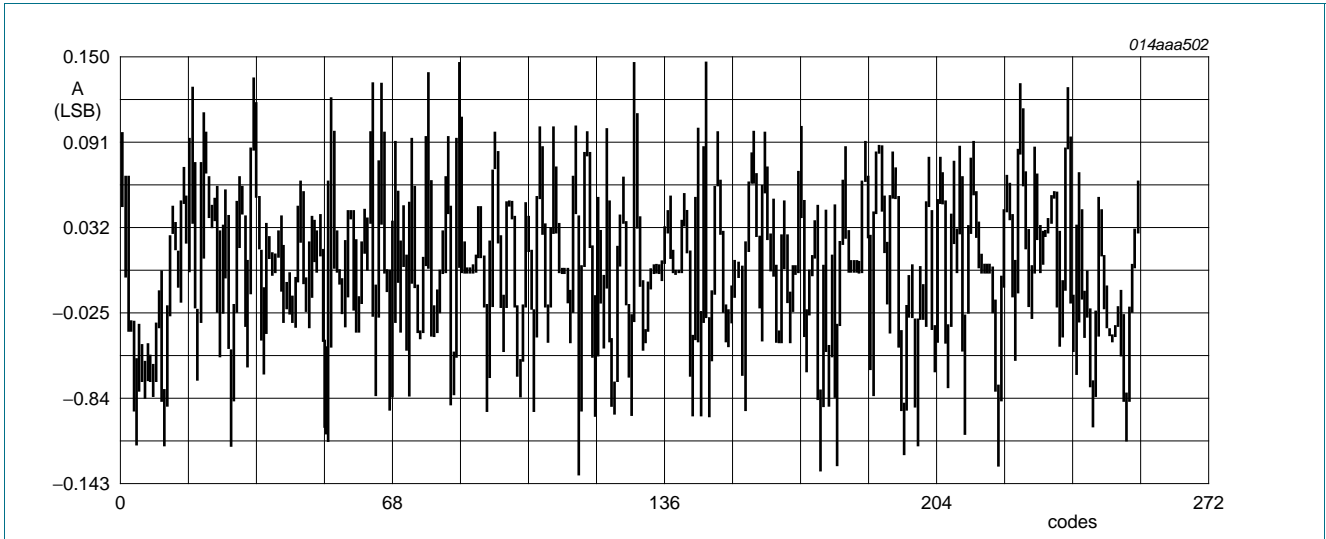

Fig 7. Typical Differential Non-Linearity (DNL) performance

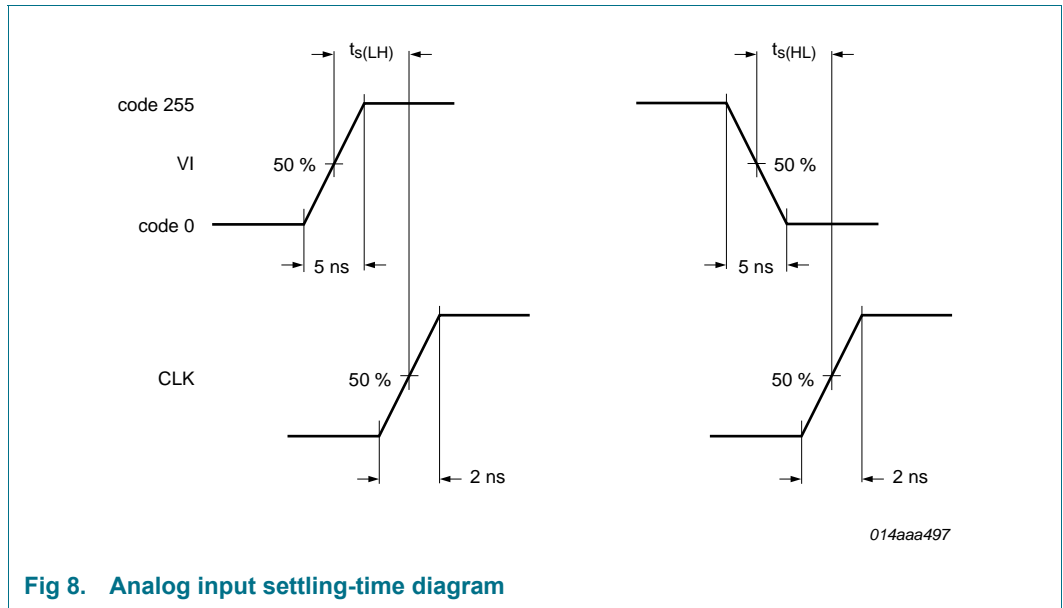
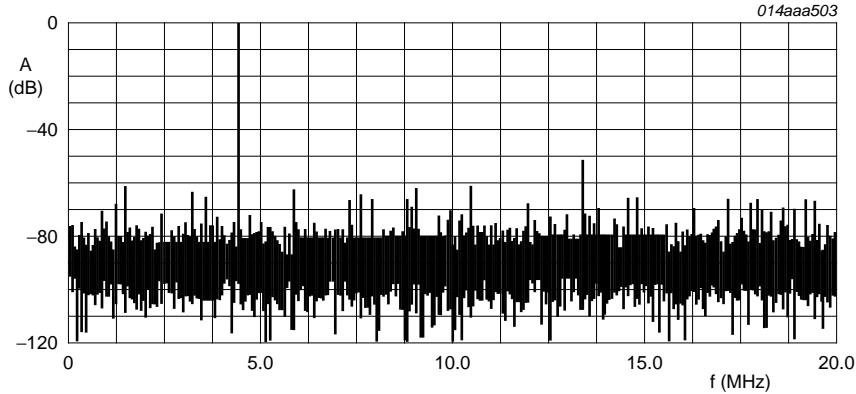

Fig 8. Analog input settling-time diagram



Effective bits: 7.32; THD = -51.08 dB.

Harmonic levels (dB): 2nd = -68.99; 3rd = -51.62; 4th = -66.05; 5th = -63.23; 6th = -72.79.

Fig 9. Typical fast Fourier transform ($f_{clk} = 40$ MHz; $f_i = 4.43$ MHz)

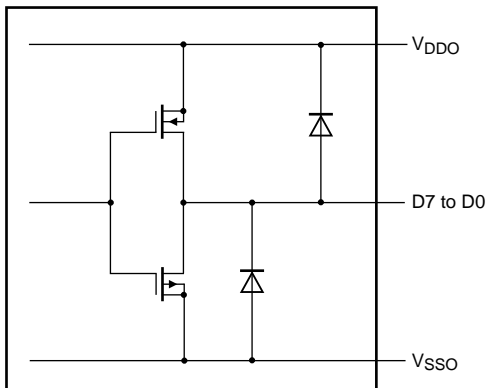

014aaa498

Fig 10. CMOS data outputs

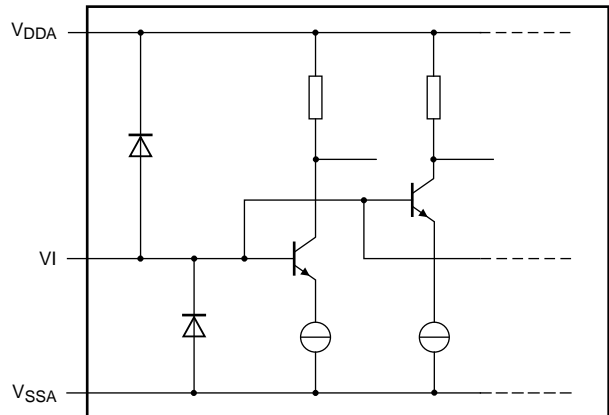

014aaa505

Fig 11. VI analog input

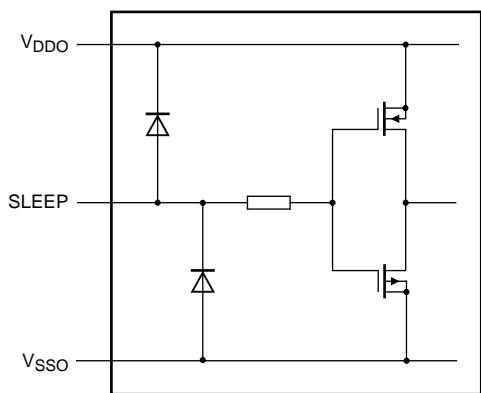

014aaa499

Fig 12. SLEEP 3-state input

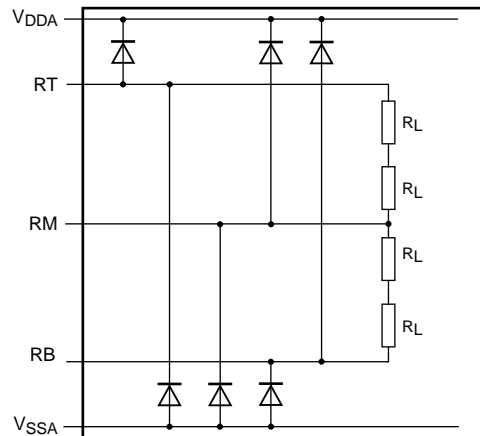

014aaa506

Fig 13. RB, RM and RT inputs

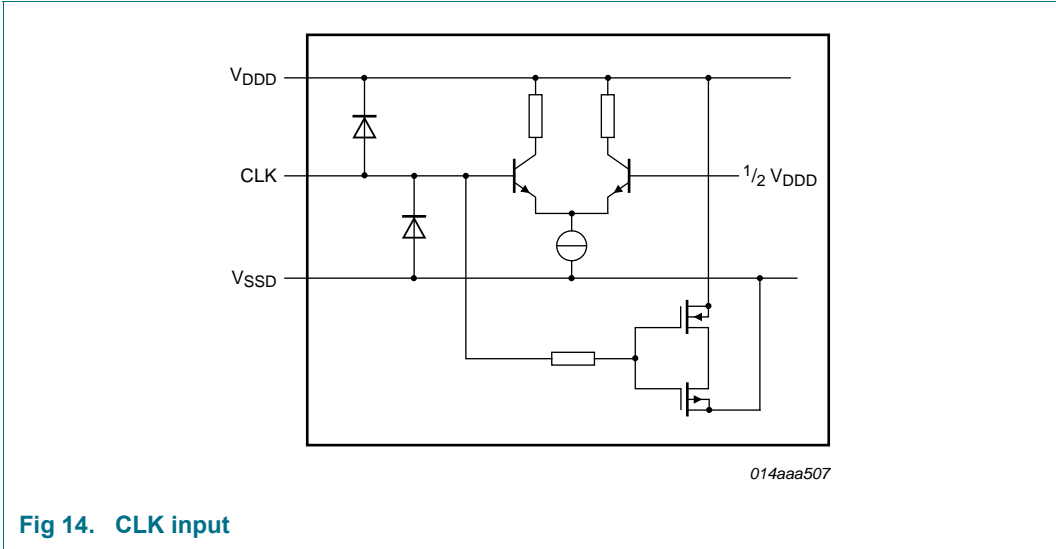

Fig 14. CLK input

12. Application information

12.1 Application diagrams

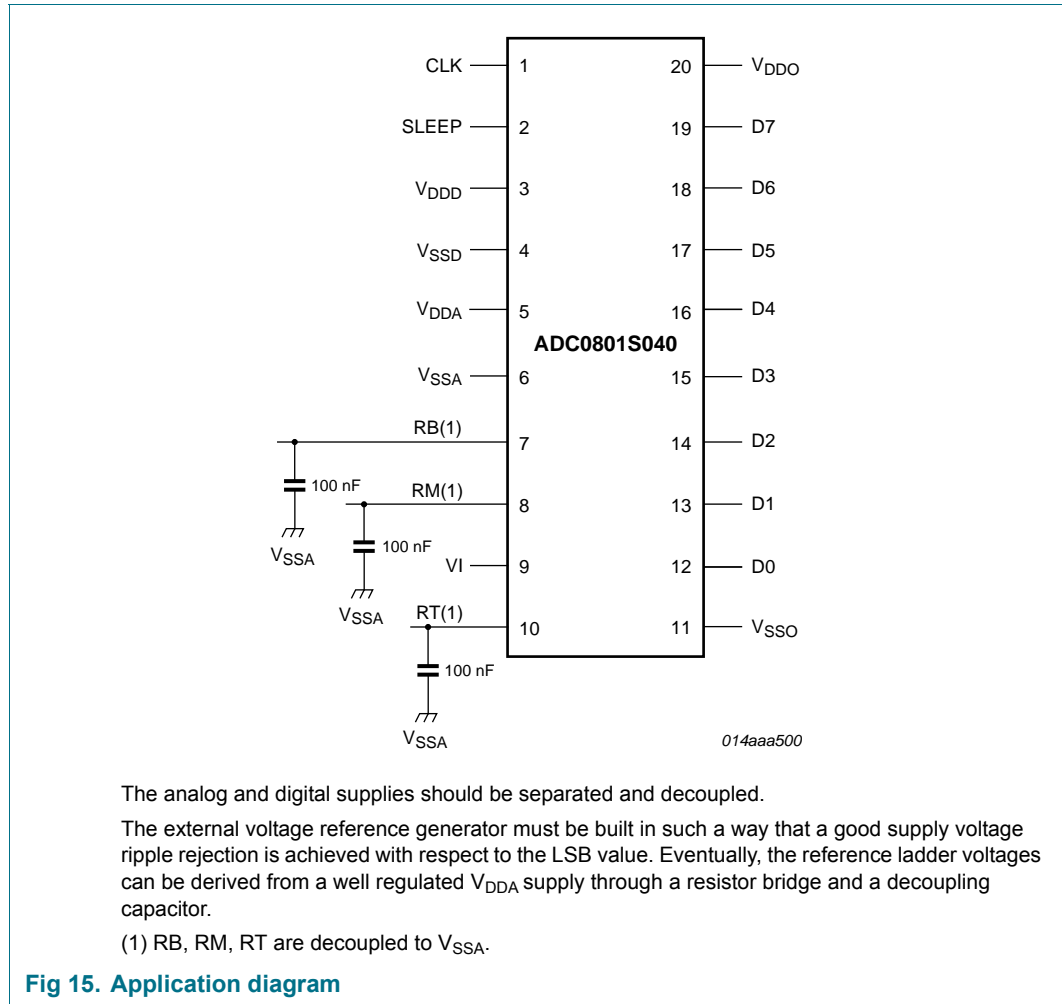

Fig 15. Application diagram

13. Package outline

SSOP20: plastic shrink small outline package; 20 leads; body width 4.4 mm

SOT266-1

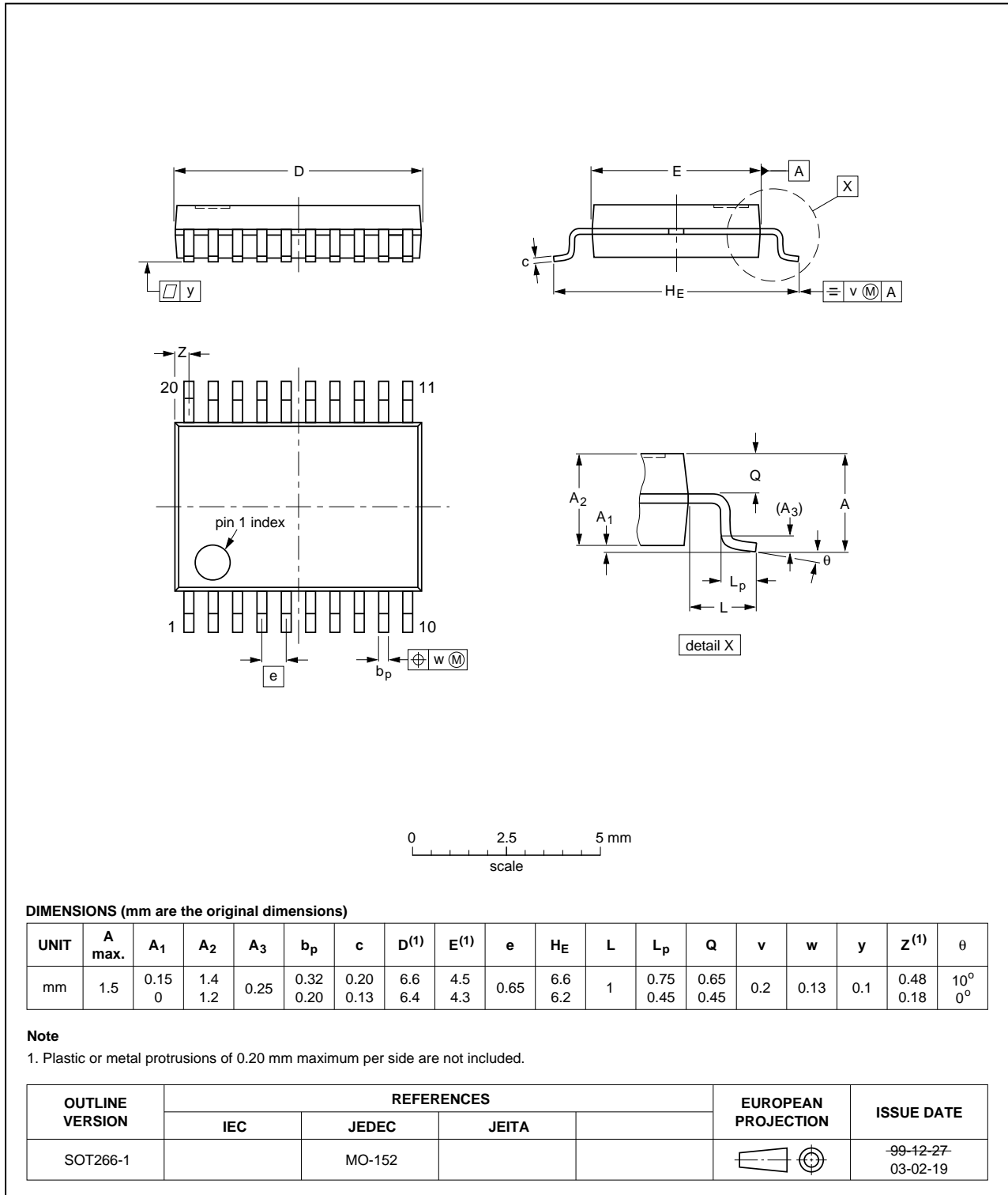

Fig 16. Package outline SOT266-1 (SSOP20)

14. Revision history

Table 9. Revision history

Document ID	Release date	Data sheet status	Change notice	Supersedes
ADC0801S040_3	20120702	Product data sheet	-	ADC0801S040_2
ADC0801S040_2	20080818	Product data sheet	-	ADC0801S040_1
Modifications:		<ul style="list-style-type: none">• Corrections made to table notes in Figure 1.• Corrections made to Table 3.• Corrections made to symbol in Table 4.• Corrections made to Table 6.• Corrections made to Figure 13		
ADC0801S040_1	20080612	Product data sheet	-	-

15. Contact information

For more information or sales office addresses, please visit: <http://www.idt.com>

16. Contents

1	General description	1	9	Thermal characteristics	5
2	Features	1	10	Characteristics	5
3	Applications	1	11	Additional information relating to Table 6 ...	9
4	Quick reference data	2	12	Application information	15
5	Ordering information	2	12.1	Application diagrams	15
6	Block diagram	3	13	Package outline	16
7	Pinning information	4	14	Revision history	17
7.1	Pinning	4	15	Contact information	17
7.2	Pin description	4	16	Contents	18
8	Limiting values	5			