

# ADC1443D series

Dual channel 14-bit ADC; 125, 160 or 200 Msps;  
JESD204B-compliant CGVxpress serial outputs

Rev. 3.4 — 10 October 2012

Data sheet

## 1. General description

The ADC1443D is a dual channel 14-bit Analog-to-Digital Converter (ADC) with JESD204B interface (which is backward compatible with the JESD204A interface) optimized for high dynamic performance and low power consumption at sample rates up to 200 Msps. Pipelined architecture and output error correction ensure that the ADC1443D is accurate enough to guarantee zero missing codes over the entire operating range.

Supplied from a single 1.8 V source, the ADC1443D has serial outputs compliant with the JESD204B standard over a configurable number of lanes (1 or 2). Multiple Device Synchronization (MDS) allows sample-accurate synchronization of the data outputs of multiple ADC devices. It guarantees a maximum skew of one clock period between as many as 16 output lanes from up to eight ADC1443D devices.

An integrated Serial Peripheral Interface (SPI) allows easy configuration of the ADC. The device also includes a programmable full-scale to allow a flexible input voltage range of 1 V (p-p) to 2 V (p-p).

With excellent dynamic performance from the baseband to input frequencies of up to 1 GHz (typical), the ADC1443D is ideal for use in undersampled multi-carrier, multistandard communication system applications. Using a pipelined architecture, an output error correction scheme ensures that the ADC1443D is accurate enough to guarantee zero missing codes over the entire operating range.

The ADC1443D is available in an HLQFN56 package (8 mm × 8 mm outline). It is supported with customer demo boards. This device is also available in a 12-bit resolution variant with a choice of maximum sampling frequency (125, 160 or 200 Msps).

## 2. Features and benefits

- Dual channel 14-bit resolution ADC
- Sampling rate up to 200 Msps
- JESD204B Device Subclass 0, 1 and 2 compliant with harmonic clocking and deterministic latency support
- ADC Multiple Device Synchronization (MDS)
- Assured interworking/interoperability with SerDes based FPGAs
- SNR = 70.6 dBFS (typical);  $f_s = 154$  Msps;  $f_i = 190$  MHz
- SFDR = 86 dBc (typical);  $f_s = 154$  Msps;  $f_i = 190$  MHz
- IMD3 = 88 dBc (typical);  $f_s = 154$  Msps;  $f_{i1} = 188.5$  MHz;  $f_{i2} = 191.5$  MHz
- Analog input bandwidth of 1 GHz (typical)
- Pin to pin compatible with ADC1413D series



- Two JESD204B serial output lanes, up to 5 Gbps typical
- Single 1.8 V supply
- Flexible input voltage range from 1 V (p-p) to 2 V (p-p) by 1 dB steps
- Clock input divider from 1 to 8 supports harmonic clocking
- Duty Cycle Stabilizer (DCS)
- Offset binary, two's complement and Gray output data
- Typical power dissipation = 0.9 W;  $f_s = 154$  Msps
- Power-down and sleep modes
- Industrial temperature range from  $-40$  °C to  $+85$  °C
- Serial Peripheral Interface (SPI) for configuration control and status monitoring
- HLQFN56 package;  $8 \times 8$  mm

### 3. Applications

- Wireless infrastructure: LTE, TD-LTE, WiMAX, MC-GSM, CDMA, WCDMA, TD-SCDMA
- Software defined radio
- Medical non-invasive scanners
- Scientific particle detectors
- Microwave backhaul transceivers
- Aerospace and defense communications and radar systems
- Industrial signal analysis instruments
- General-purpose high-speed applications

### 4. Ordering information

Table 1. Ordering information

Type number	$f_s$ (Msps)	Package		
		Name	Description	Version
ADC1443D200HD	200	HLQFN56	plastic thermal enhanced low profile quad flat package; no leads; 56 terminals; resin based; body $8 \times 8 \times 1.35$ mm	SOT935-2
ADC1443D160HD	160	HLQFN56	plastic thermal enhanced low profile quad flat package; no leads; 56 terminals; resin based; body $8 \times 8 \times 1.35$ mm	SOT935-2
ADC1443D125HD	125	HLQFN56	plastic thermal enhanced low profile quad flat package; no leads; 56 terminals; resin based; body $8 \times 8 \times 1.35$ mm	SOT935-2

## 5. Block diagram

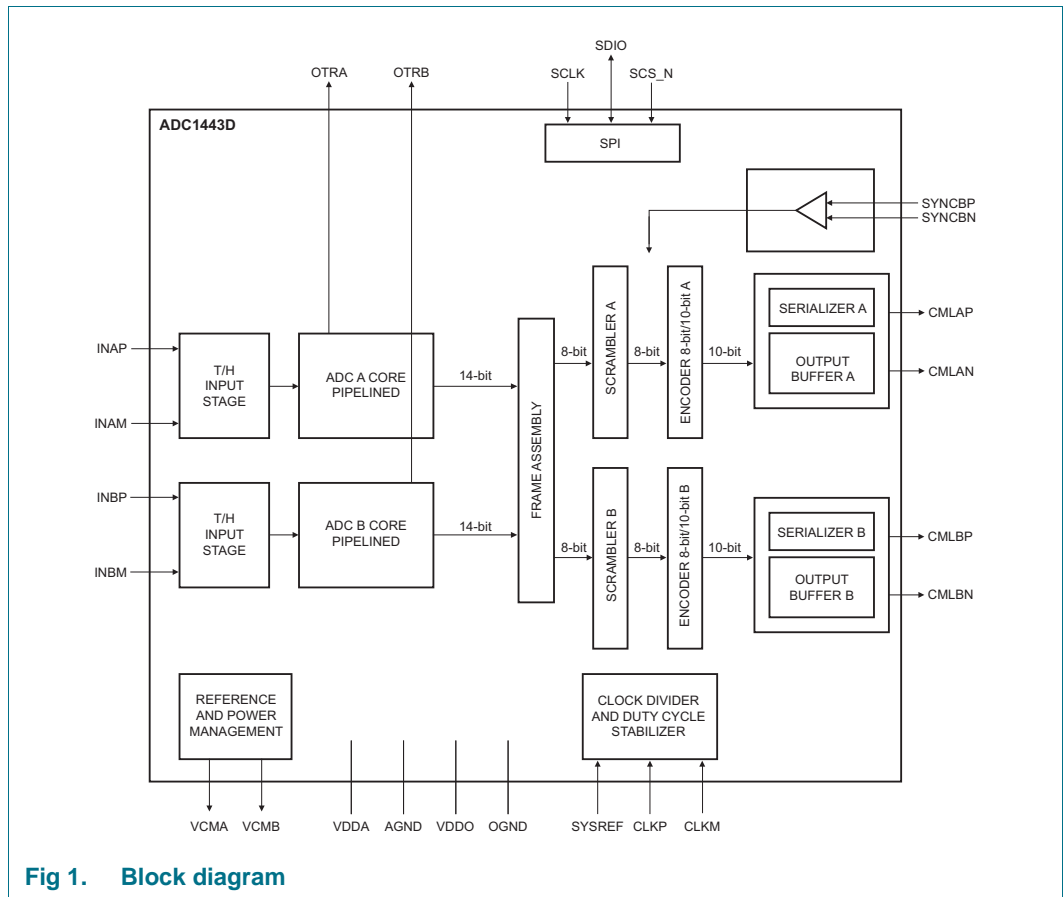
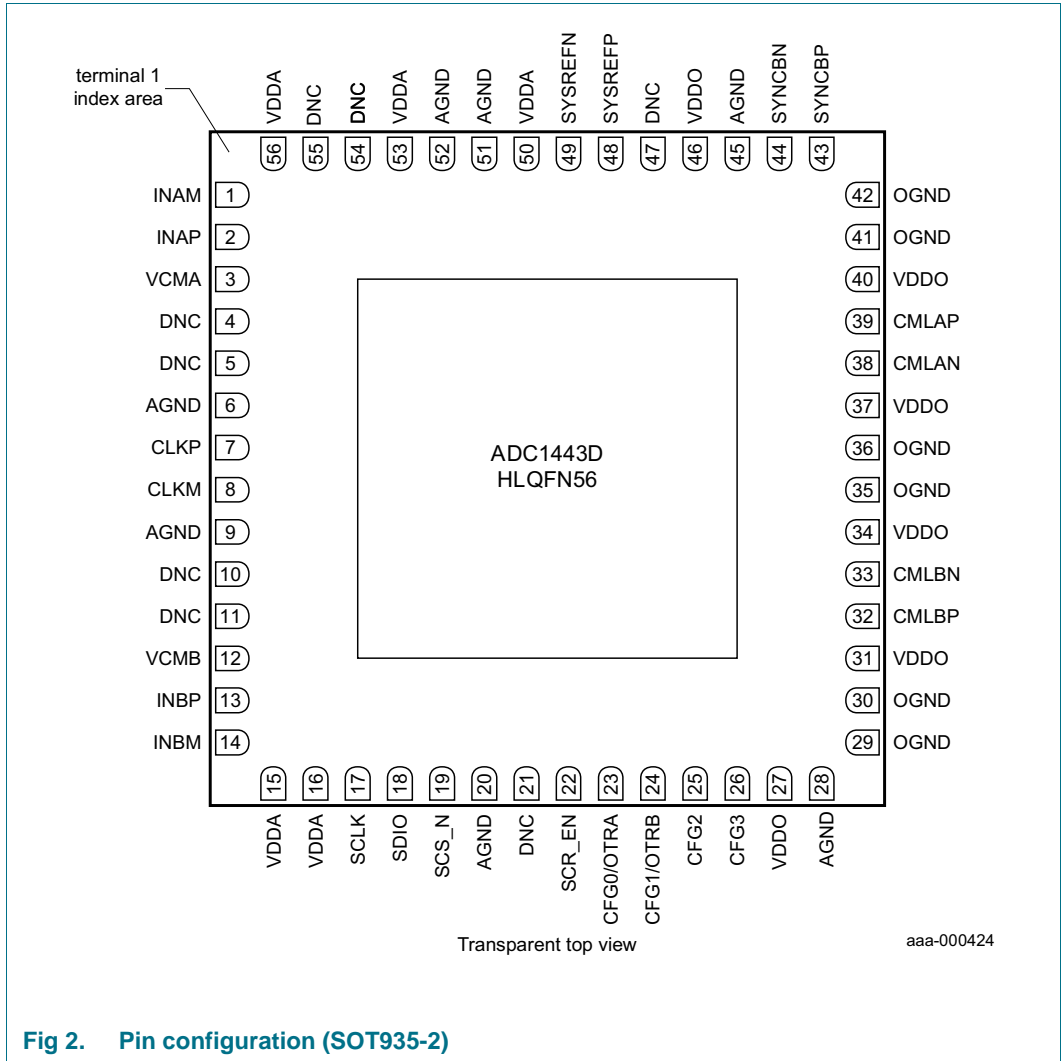

Fig 1. Block diagram

## 6. Pinning information

### 6.1 Pinning



## 6.2 Pin description

Table 2. Pin description

Symbol	Pin	Type <sup>[1]</sup>	Description
INAM	1	I	channel A complementary analog input
INAP	2	I	channel A analog input
VCMA	3	O	channel A output common voltage
DNC	4	-	do not connect
DNC	5	-	do not connect
AGND	6	G	analog ground
CLKP	7	I	clock input
CLKN	8	I	complementary clock input
AGND	9	G	analog ground
DNC	10	-	do not connect
DNC	11	-	do not connect
VCMB	12	O	channel B output common voltage
INBP	13	I	channel B analog input
INBM	14	I	channel B complementary analog input
VDDA	15	P	analog power supply
VDDA	16	P	analog power supply
SCLK	17	I	SPI clock
SDIO	18	I/O	SPI data IO
SCS_N	19	I	SPI chip select
AGND	20	G	analog ground
DNC	21	-	do not connect
SCR_EN	22	I	scrambler enable
CFG0/OTRA	23	I/O	configuration pin 0/OuT of Range A (OTRA)
CFG1/OTRB	24	I/O	configuration pin 1/OuT of Range B (OTRB)
CFG2	25	I/O	configuration pin 2
CFG3	26	I/O	configuration pin 3
VDDO	27	P	digital output power supply
AGND	28	G	analog ground
OGND	29	G	digital output ground
OGND	30	G	digital output ground
VDDO	31	P	digital output power supply
CMLBP	32	O	channel B output
CMLBN	33	O	channel B complementary output
VDDO	34	P	digital output power supply
OGND	35	G	digital output ground
OGND	36	G	digital output ground
VDDO	37	P	digital output power supply
CMLAN	38	O	channel A complementary output
CMLAP	39	O	channel A output

Table 2. Pin description ...continued

Symbol	Pin	Type <sup>[1]</sup>	Description
VDDO	40	P	digital output power supply
OGND	41	G	digital output ground
OGND	42	G	digital output ground
SYNCBP	43	I	JESD204B SYNC synchronization signal from receiver
SYNCBN	44	I	complementary SYNC from receiver
AGND	45	G	analog ground
VDDO	46	P	digital power
DNC	47	-	do not connect
SYSREFP	48	I	positive clock synchronization
SYSREFN	49	I	negative clock synchronization
VDDA	50	P	analog power supply
AGND	51	G	analog ground
AGND	52	G	analog ground
VDDA	53	P	analog power supply
DNC	54	-	do not connect
DNC	55	-	do not connect
VDDA	56	P	analog power supply
AGND	EXP	G	Expose PAD

[1] P: power supply; G: ground; I: input; O: output; I/O: input/output.

## 7. Limiting values

**Table 3. Limiting values**

*In accordance with the Absolute Maximum Rating System (IEC 60134).*

Symbol	Parameter	Conditions	Min	Max	Unit
V <sub>DDA</sub>	analog supply voltage		-0.3	+2.1	V
V <sub>DDO</sub>	output supply voltage		-0.3	+2.1	V
ΔV <sub>DD</sub>	supply voltage difference	V <sub>DDA</sub> - V <sub>DDO</sub>	-0.8	+0.8	V
V <sub>I</sub>	input voltage	pins INP, INM, CLKP and CLKM; referenced to AGND	-0.3	V <sub>DDA</sub> + 0.3	V
		pins OTR, SCS_N, SDIO, SCLK, CFG, SCR_EN, SYSREFP, SYSREFN, SYNCBP, and SYNCBN; referenced to AGND	-0.3	V <sub>DDO</sub> + 0.3	V
V <sub>O</sub>	output voltage	pin VCM; referenced to AGND	-0.3	V <sub>DDA</sub> + 0.3	V
		pins CMLP, and CMLN; referenced to OGND	-0.3	V <sub>DDO</sub> + 0.3	V
T <sub>stg</sub>	storage temperature		-55	+125	°C
T <sub>amb</sub>	ambient temperature		-40	+85	°C
T <sub>j</sub>	junction temperature		-	125	°C

## 8. Thermal characteristics

**Table 4. Thermal characteristics**

Symbol	Parameter	Conditions	Typ	Unit
R <sub>th(j-a)</sub>	thermal resistance from junction to ambient		[1] 22.7	K/W
R <sub>th(j-c)</sub>	thermal resistance from junction to case		[1] 9.3	K/W

[1] In compliance with JEDEC test board, in free air.

## 9. Static characteristics

**Table 5. Static characteristics**<sup>[1]</sup>

Symbol	Parameter	Conditions	Min	Typ	Max	Unit
<b>Supplies</b>						
V <sub>DDA</sub>	analog supply voltage		1.7	1.8	1.9	V
V <sub>DDO</sub>	output supply voltage		1.7	1.8	1.9	V
I <sub>DDA</sub>	analog supply current	f <sub>s</sub> = 185 Msps; f <sub>i</sub> = 190 MHz	-	410	<td>	mA
I <sub>DDO</sub>	output supply current	f <sub>s</sub> = 185 Msps; f <sub>i</sub> = 190 MHz	-	173	<td>	mA

Table 5. Static characteristics<sup>[1]</sup> ...continued

Symbol	Parameter	Conditions	Min	Typ	Max	Unit
P <sub>tot</sub>	total power dissipation	f <sub>i</sub> = 190 MHz				
		ADC1443D125; f <sub>s</sub> = 125 Msps	-	0.71	0.9	W
		ADC1443D160; f <sub>s</sub> = 154 Msps	-	0.9	<tbid>	W
		ADC1443D200; f <sub>s</sub> = 185 Msps	-	1.05	<tbid>	W
		Power-down mode	-	10	-	mW
	Sleep mode	-	115	-	mW	
<b>Clock inputs: pins CLKP and CLKM (AC-coupled; peak-to-peak)</b>						
V <sub>i(clk)</sub>	clock input voltage	LVPECL	-	±0.8	-	V
		LVDS	-	±0.35	-	V
		SINE differential	±0.5	±1.5	-	V
		LVC MOS single	-	V <sub>DDA</sub>	-	V
C <sub>i</sub>	input capacitance		-	1.2	-	pF
<b>Logic inputs</b>						
I <sub>IL</sub>	LOW-level input current	absolute value	-	30	-	μA
I <sub>IH</sub>	HIGH-level input current	absolute value	-	70	-	μA
C <sub>i</sub>	input capacitance		-	1.2	-	pF
<b>pins SYSREFP, SYSREFN, SYNCBP, and SYNCBN</b>						
V <sub>i(cm)</sub>	common-mode input voltage		0.925	1.2	1.475	V
V <sub>i(dif)</sub>	differential input voltage		0.2	0.7	-	V
<b>pins SCS_N, SDIO, SCLK, SCR_EN and CFG</b>						
V <sub>IL</sub>	LOW-level input voltage		0	-	0.3V <sub>DDO</sub>	V
V <sub>IH</sub>	HIGH-level input voltage		0.7V <sub>DDO</sub>	-	V <sub>DDO</sub>	V
<b>Logic output: pins CFG and SDIO</b>						
V <sub>OL</sub>	LOW-level output voltage		0	-	0.2	V
V <sub>OH</sub>	HIGH-level output voltage		V <sub>DDO</sub> -0.2	-	V <sub>DDO</sub>	V
<b>Digital outputs: pins CMLAP, CMLAN, CMLBP, and CMLBN</b>						
V <sub>O(cm)</sub>	common-mode output voltage	default current	-	1.4	-	V
V <sub>O(dif)</sub>	differential output voltage	default current; peak-to-peak	-	800	-	mV
<b>Analog inputs: pins INP and INM</b>						
I <sub>i</sub>	input current		-	±5	-	μA
R <sub>i</sub>	input resistance	f <sub>i</sub> = 190 MHz	-	<tbid>	-	Ω
C <sub>i</sub>	input capacitance	f <sub>i</sub> = 190 MHz	-	5	-	pF
V <sub>I(cm)</sub>	common-mode input voltage	V <sub>INP</sub> = V <sub>INM</sub>	<tbid>	0.9	<tbid>	V
B <sub>i</sub>	input bandwidth		-	1	-	GHz
V <sub>I(dif)</sub>	differential input voltage	peak-to-peak; full-scale	1	-	2	V
<b>Common-mode output voltage: pins VCMA and VCMB</b>						
V <sub>O(cm)</sub>	common-mode output voltage		-	0.9	-	V
I <sub>O(cm)</sub>	common-mode output current	T <sub>amb</sub> = 25 °C	-	-	1	mA

Table 5. Static characteristics<sup>[1]</sup> ...continued

Symbol	Parameter	Conditions	Min	Typ	Max	Unit
<b>Accuracy</b>						
INL	integral non-linearity	$f_s = 185$ Msps; $f_i = 4.43$ MHz	<td>	4.4	<td>	LSB
DNL	differential non-linearity	$f_s = 185$ Msps; $f_i = 4.43$ MHz; guaranteed no missing codes	<td>	-0.24 +0.48	<td>	LSB
$E_{\text{offset}}$	offset error		-	<td>	-	mV
$E_G$	gain error	full-scale	-	<td>	-	%
$M_{G(\text{CTC})}$	channel-to-channel gain matching		-	<td>	-	%
<b>Supply</b>						
PSRR	power supply rejection ratio	<td> mV (p-p) on $V_{\text{DDA}}$	-	<td>	-	dB

[1] Typical values measured at  $V_{\text{DDA}} = V_{\text{DDO}} = 1.8$  V;  $T_{\text{amb}} = 25$  °C. Minimum and maximum values are across the full temperature range  $T_{\text{amb}} = -40$  °C to  $+85$  °C at  $V_{\text{DDA}} = V_{\text{DDO}} = 1.8$  V;  $V_{\text{I}(\text{dif})} = 2$  V;  $V_{\text{INP}} - V_{\text{INM}} = -1$  dBFS; unless otherwise specified.

## 10. Dynamic characteristics

### 10.1 Dynamic characteristics

Table 6. Dynamic characteristics<sup>[1]</sup>

Symbol	Parameter	Conditions	ADC1443D125 ( $f_s = 125$ Msps)			ADC1443D160 ( $f_s = 154$ Msps)			ADC1443D200 ( $f_s = 185$ Msps)			Unit
			Min	Typ	Max	Min	Typ	Max	Min	Typ	Max	
$\alpha_{2H}$	second harmonic level	$f_i = 5$ MHz	-	-87	-	-	-84	-	-	<tbid>	-	dBc
		$f_i = 70$ MHz	-	-85	-	-	-82	-	-	<tbid>	-	dBc
		$f_i = 140$ MHz	-	-92	-	-	-85	-	-	<tbid>	-	dBc
		$f_i = 170$ MHz	-	-83	-	-	-83	-	-	<tbid>	-	dBc
		$f_i = 190$ MHz	-	-82	-	-	-86	-	-	<tbid>	-	dBc
		$f_i = 230$ MHz	-	-78	-	-	-80	-	-	<tbid>	-	dBc
$\alpha_{3H}$	third harmonic level	$f_i = 5$ MHz	-	-100	-	-	-88	-	-	<tbid>	-	dBc
		$f_i = 70$ MHz	-	-97	-	-	-90	-	-	<tbid>	-	dBc
		$f_i = 140$ MHz	-	-88	-	-	-89	-	-	<tbid>	-	dBc
		$f_i = 170$ MHz	-	-94	-	-	-90	-	-	<tbid>	-	dBc
		$f_i = 190$ MHz	-	-96	-	-	-87	-	-	<tbid>	-	dBc
		$f_i = 230$ MHz	-	-95	-	-	-85	-	-	<tbid>	-	dBc
SFDR	spurious-free dynamic range	$f_i = 5$ MHz	-	87	-	-	84	-	-	<tbid>	-	dBc
		$f_i = 70$ MHz	-	85	-	-	82	-	-	<tbid>	-	dBc
		$f_i = 140$ MHz	-	92	-	-	85	-	-	<tbid>	-	dBc
		$f_i = 170$ MHz	-	83	-	-	83	-	-	<tbid>	-	dBc
		$f_i = 190$ MHz	-	82	-	-	86	-	-	<tbid>	-	dBc
		$f_i = 230$ MHz	-	78	-	-	80	-	-	<tbid>	-	dBc
THD	total harmonic distortion	$f_i = 5$ MHz	-	-86.5	-	-	-82.3	-	-	<tbid>	-	dBc
		$f_i = 70$ MHz	-	-84.2	-	-	-80	-	-	<tbid>	-	dBc
		$f_i = 140$ MHz	-	-85.3	-	-	-82.8	-	-	<tbid>	-	dBc
		$f_i = 170$ MHz	-	-81.8	-	-	-81.7	-	-	<tbid>	-	dBc
		$f_i = 190$ MHz	-	-81.4	-	-	-81.9	-	-	<tbid>	-	dBc
		$f_i = 230$ MHz	-	-77.5	-	-	-78.5	-	-	<tbid>	-	dBc

Table 6. Dynamic characteristics<sup>[1]</sup> ...continued

Symbol	Parameter	Conditions	ADC1443D125 ( $f_s = 125$ Msps)			ADC1443D160 ( $f_s = 154$ Msps)			ADC1443D200 ( $f_s = 185$ Msps)			Unit
			Min	Typ	Max	Min	Typ	Max	Min	Typ	Max	
IMD3	third-order intermodulation distortion	$f_{i1} = 3.5$ MHz; $f_{i2} = 6.5$ MHz	-	91	-	-	90	-	-	<tbid>	-	dBc
		$f_{i1} = 68.5$ MHz; $f_{i2} = 71.5$ MHz	-	90	-	-	89	-	-	<tbid>	-	dBc
		$f_{i1} = 138.5$ MHz; $f_{i2} = 141.5$ MHz	-	89	-	-	88	-	-	<tbid>	-	dBc
		$f_{i1} = 168.5$ MHz; $f_{i2} = 171.5$ MHz	-	91	-	-	88	-	-	<tbid>	-	dBc
		$f_{i1} = 188.5$ MHz; $f_{i2} = 191.5$ MHz	-	88	-	-	87	-	-	<tbid>	-	dBc
		$f_{i1} = 228.5$ MHz; $f_{i2} = 231.5$ MHz	-	87	-	-	87	-	-	<tbid>	-	dBc
SNR	signal-to-noise ratio	$f_i = 5$ MHz	-	72.6	-	-	71.9	-	-	<tbid>	-	dBFS
		$f_i = 70$ MHz	-	72.4	-	-	71.7	-	-	<tbid>	-	dBFS
		$f_i = 140$ MHz	-	72.1	-	-	71.3	-	-	<tbid>	-	dBFS
		$f_i = 170$ MHz	-	71.6	-	-	70.8	-	-	<tbid>	-	dBFS
		$f_i = 190$ MHz	-	71.2	-	-	70.6	-	-	<tbid>	-	dBFS
		$f_i = 230$ MHz	-	70.6	-	-	70	-	-	<tbid>	-	dBFS
ENOB	effective number of bits	$f_i = 5$ MHz	-	11.7	-	-	11.4	-	-	<tbid>	-	bit
		$f_i = 70$ MHz	-	11.7	-	-	11.4	-	-	<tbid>	-	bit
		$f_i = 140$ MHz	-	11.7	-	-	11.3	-	-	<tbid>	-	bit
		$f_i = 170$ MHz	-	11.5	-	-	11.3	-	-	<tbid>	-	bit
		$f_i = 190$ MHz	-	11.5	-	-	11.2	-	-	<tbid>	-	bit
		$f_i = 230$ MHz	-	11.3	-	-	11.1	-	-	<tbid>	-	bit
$\alpha_{ct(ch)}$	channel crosstalk	$f_i = 140$ MHz	-	95	-	-	95	-	-	<tbid>	-	dBc
		$f_i = 230$ MHz	-	90	-	-	90	-	-	<tbid>	-	dBc

[1] Typical values measured at  $V_{DDA} = V_{DDO} = 1.8$  V;  $T_{amb} = 25$  °C. Minimum and maximum values are across the full temperature range  $T_{amb} = -40$  °C to  $+85$  °C at  $V_{DDA} = V_{DDO} = 1.8$  V;  $V_{I(dif)} = 2$  V;  $V_{INP} - V_{INM} = -1$  dBFS; unless otherwise specified.

## 10.2 Timing

### 10.2.1 Clock timing

Table 7. Clock and digital output timing characteristics<sup>[1]</sup>

Symbol	Parameter	Conditions	Min	Typ	Max	Unit
$t_{lat(data)}$	data latency time		-	42	-	clock cycles
$t_{wake}$	wake-up time	from Power-down mode	-	<td>	-	ns
		from Sleep mode	-	<td>	-	ns
		from high impedance	-	<td>	-	ns
<b>Clock timing</b>						
$f_s$	sampling rate	ADC1443D125	60	-	125	MHz
		ADC1443D160	125	-	160	MHz
		ADC1443D200	160	-	200	MHz
$f_{clk}$	clock frequency		60	-	800	MHz
$\delta_{clk}$	clock duty cycle		30	-	70	%
$t_{d(s)}$	sampling delay time		-	<td>	-	ns

[1] Typical values measured at  $V_{DDA} = V_{DDO} = 1.8\text{ V}$ ;  $T_{amb} = 25\text{ }^\circ\text{C}$ . Minimum and maximum values are across the full temperature range  $T_{amb} = -40\text{ }^\circ\text{C}$  to  $85\text{ }^\circ\text{C}$  at  $V_{DDA} = V_{DDO} = 1.8\text{ V}$ ;  $V_{I(dif)} = 2\text{ V}$ ;  $V_{INP} - V_{INM} = -1\text{ dBFS}$ ; unless otherwise specified.

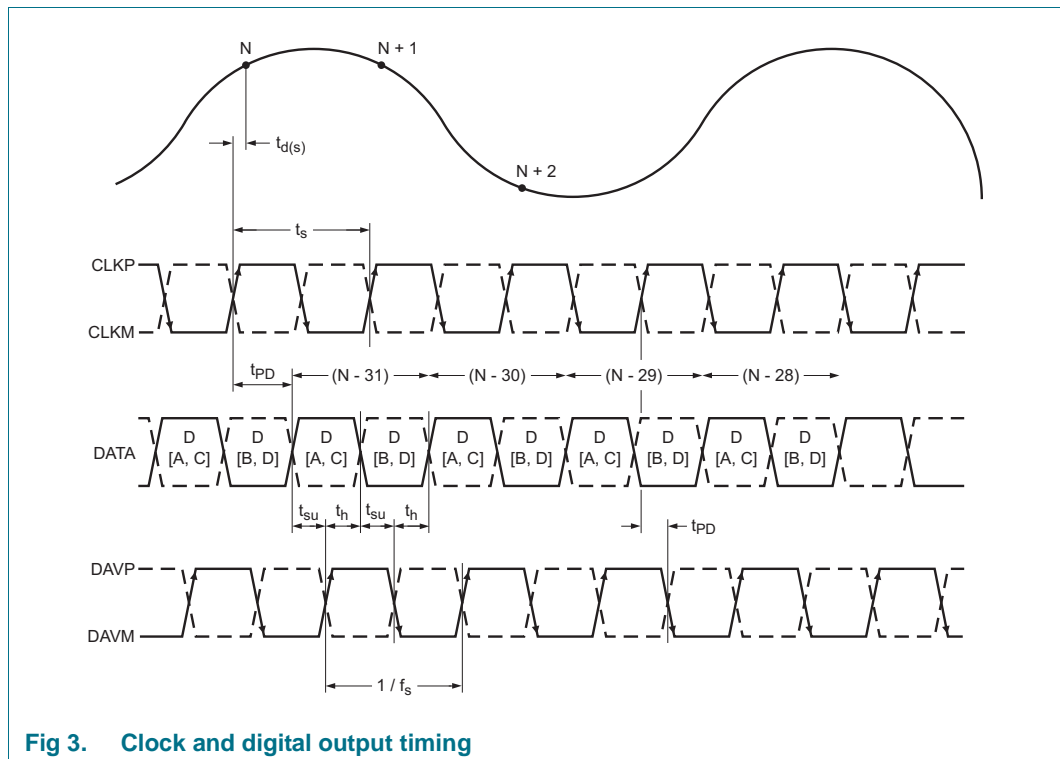

Fig 3. Clock and digital output timing

10.2.2 SYSREF timing

Table 8. SYSREF timing

Symbol	Parameter	Conditions	Min	Typ	Max	Unit
$t_{su}$	set-up time		<td>	-	-	ns
$t_h$	hold time		<td>	-	-	ns

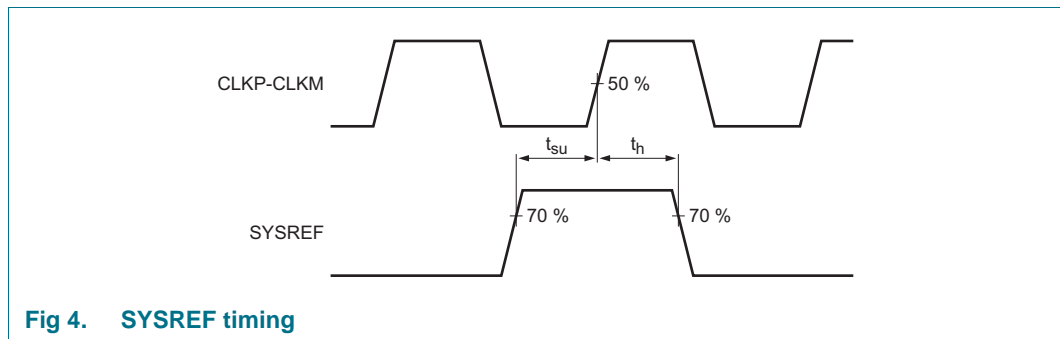

Fig 4. SYSREF timing

10.2.3 SPI timing

Table 9. SPI timing characteristics [1]

Symbol	Parameter	Conditions	Min	Typ	Max	Unit
$t_{w(SCLK)}$	SCLK pulse width		40	-	-	ns
$t_{w(SCLKH)}$	SCLK HIGH pulse width		16	-	-	ns
$t_{w(SCLKL)}$	SCLK LOW pulse width		16	-	-	ns
$t_{su}$	set-up time	SDIO to SCLK HIGH	5	-	-	ns
		SCS_N to SCLK HIGH	5	-	-	ns
$t_h$	hold time	SDIO to SCLK HIGH	2	-	-	ns
		SCS_N to SCLK HIGH	2	-	-	ns
$f_{clk}$	clock frequency		-	-	25	MHz

[1] Typical values measured at  $V_{DDA} = V_{DDO} = 1.8\text{ V}$ ;  $T_{amb} = 25\text{ }^\circ\text{C}$ . Minimum and maximum values are across the full temperature range  $T_{amb} = -40\text{ }^\circ\text{C}$  to  $+85\text{ }^\circ\text{C}$  at  $V_{DDA} = V_{DDO} = 1.8\text{ V}$

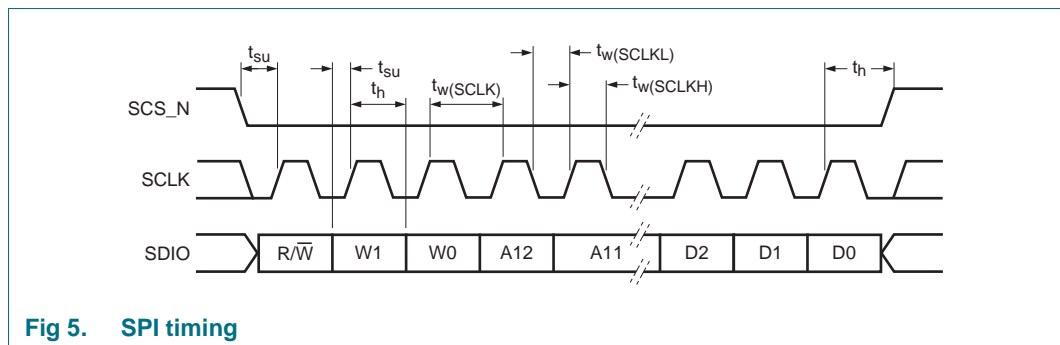

Fig 5. SPI timing

10.3 Typical dynamic performances<sup>1</sup>

10.3.1 Typical FFT at 122.88 Msps

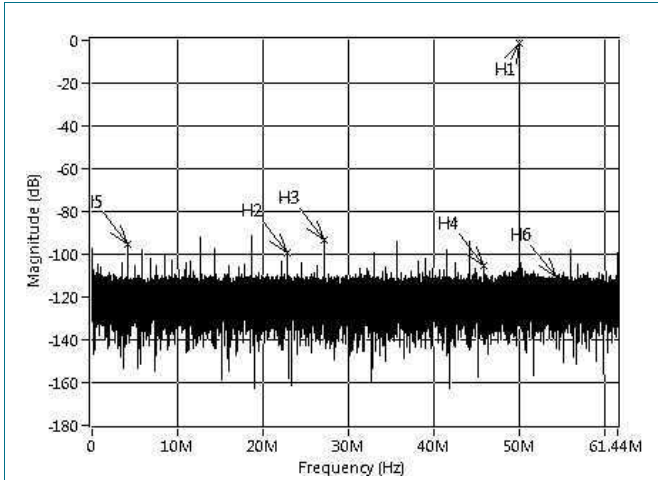

Fig 6. 1-tone FFT: -1 dBFS;  $f_i = 50$  MHz;  $f_s = 122.88$  Msps

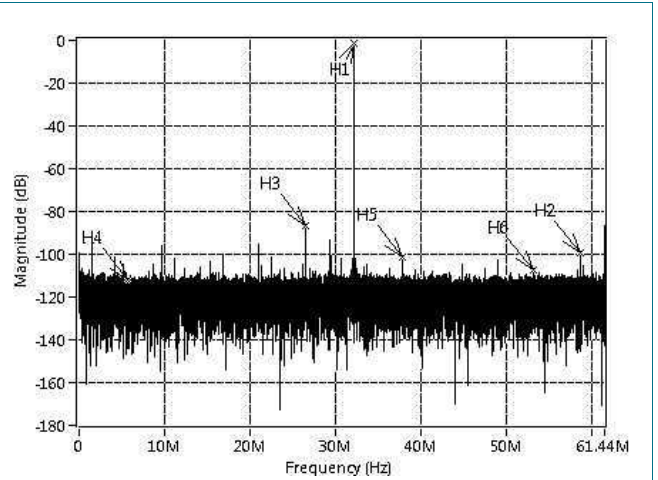

Fig 7. 1-tone FFT: -1 dBFS;  $f_i = 155$  MHz;  $f_s = 122.88$  Msps

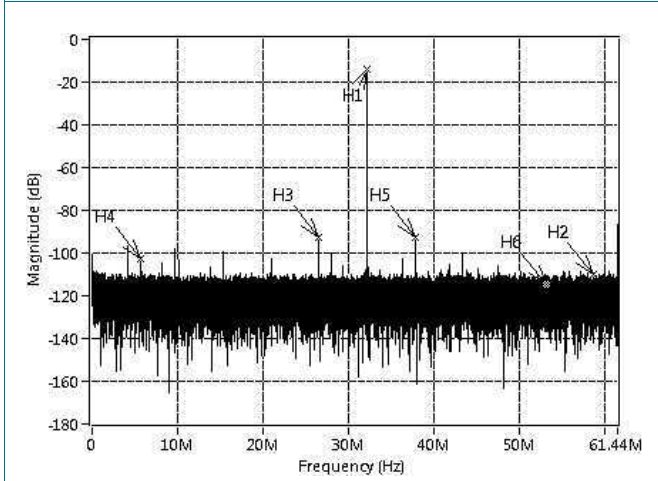

Fig 8. 1-tone FFT: -14 dBFS;  $f_i = 155$  MHz;  $f_s = 122.88$  Msps

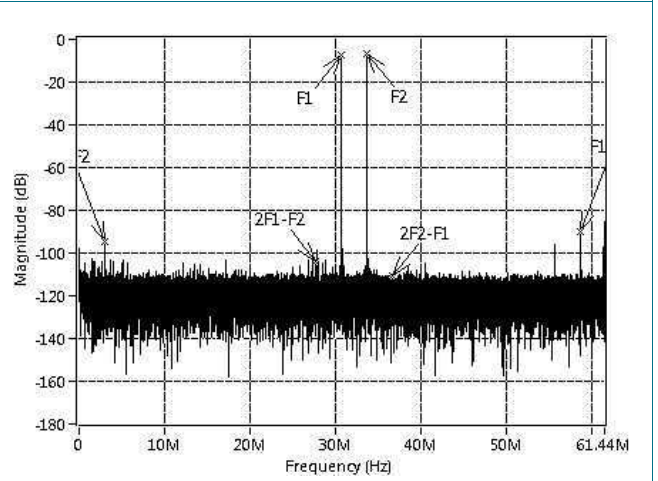

Fig 9. SNR as a function of full-scale amplitude: -1 dBFS;  $f_i = 190$  MHz;  $f_s = 185$  Msps

1. Typical values measured at  $V_{DDA} = V_{DDO} = 1.8$  V;  $T_{amb} = 25$  °C

10.3.2 Typical FFT at 153.6 Msps

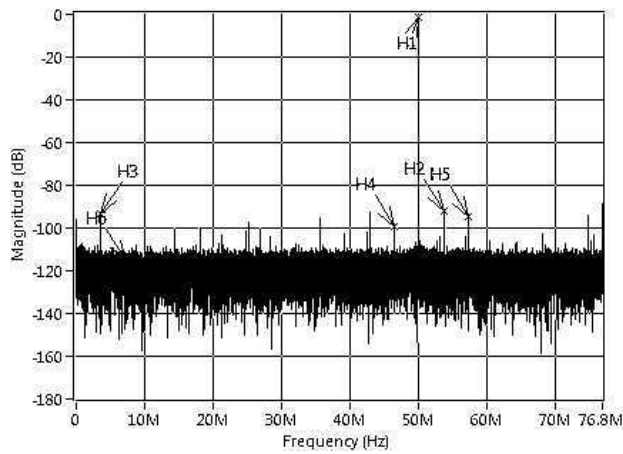

Fig 10. 1-tone FFT: -1 dBFS;  $f_i = 50$  MHz;  $f_s = 153.6$  Msps

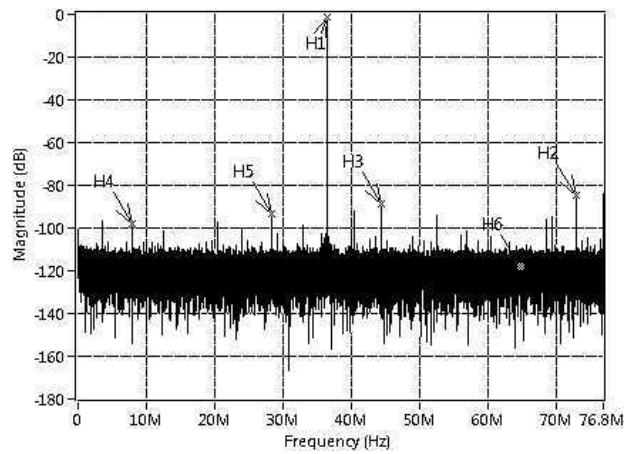

Fig 11. 1-tone FFT: -1 dBFS;  $f_i = 190$  MHz;  $f_s = 153.6$  Msps

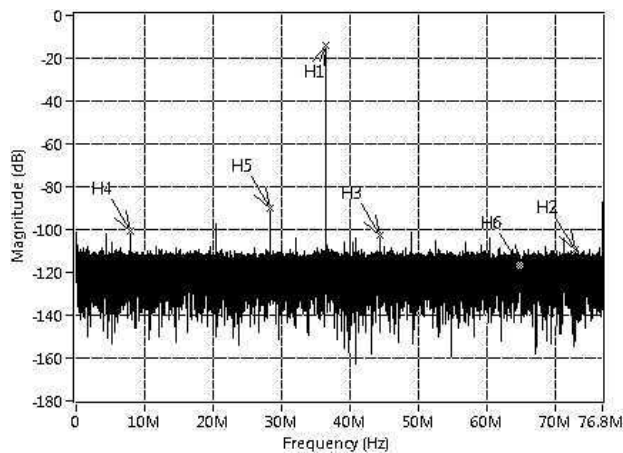

Fig 12. 1-tone FFT: -14 dBFS;  $f_i = 190$  MHz;  $f_s = 153.6$  Msps

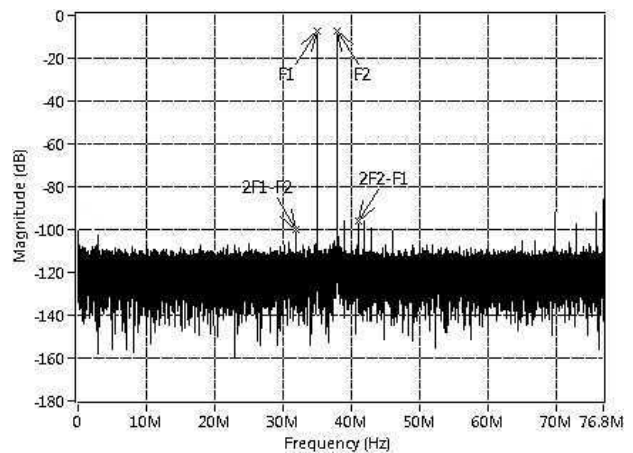
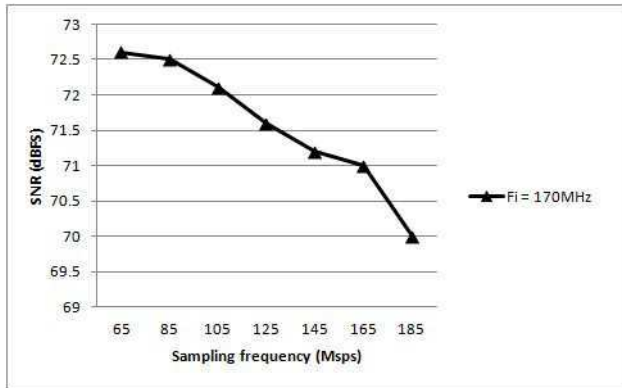
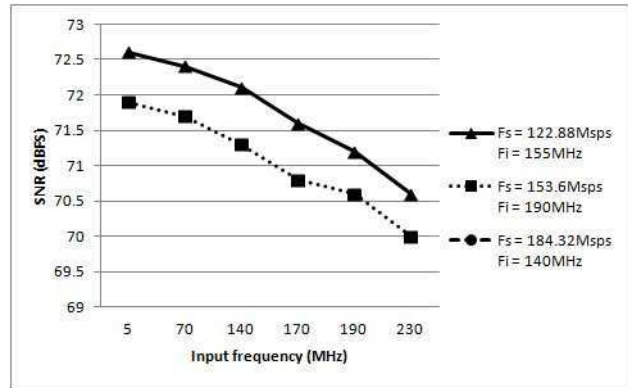

Fig 13. 2-tone FFT: -7 dBFS;  $f_{i1} = 188.5$  MHz;  $f_{i2} = 191.5$  MHz;  $f_s = 153.6$  Msps

### 10.3.3 Typical SNR performances



**Fig 14. SNR as a function of sampling frequency:**  
-1 dBFS;  $f_i = 170$  MHz



**Fig 15. SNR as a function of input frequency:** -1 dBFS

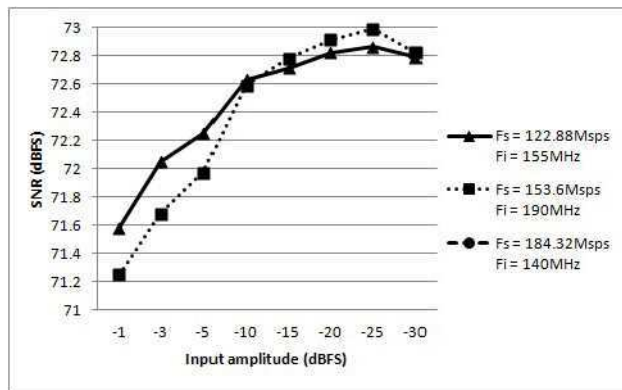

**Fig 16. SNR as a function of input amplitude:**  
 $f_i = 190$  MHz;  $f_s = 185$  Msps;  $V_{l(dif)} = 2$  V

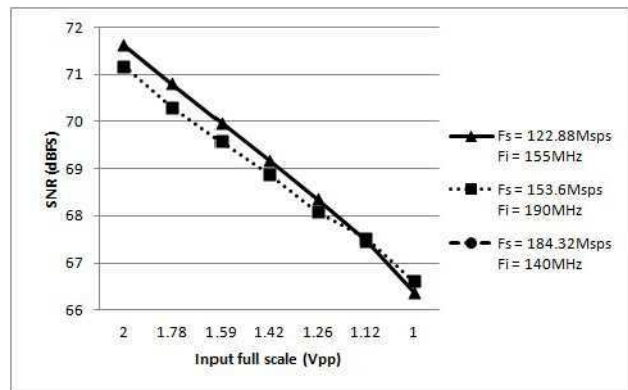

**Fig 17. SFDR as a function of full-scale amplitude:**  
-1 dBFS;  $f_i = 190$  MHz;  $f_s = 185$  Msps

10.3.4 Typical SFDR performances

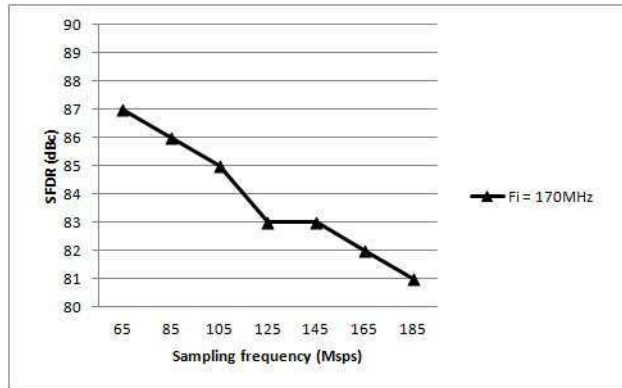

Fig 18. SFDR as a function of sampling frequency: -1 dBFS;  $f_i = 170$  MHz

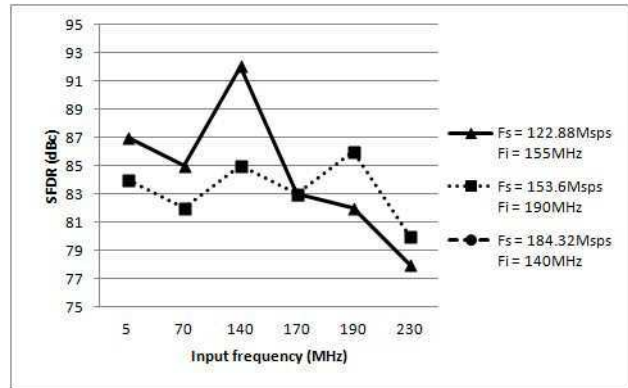

Fig 19. SFDR as a function of input frequency: -1 dBFS

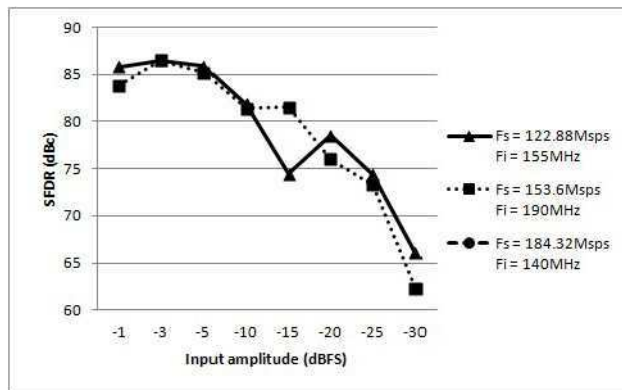

Fig 20. SFDR as a function of input amplitude:  $V_{I(dif)} = 2$  V

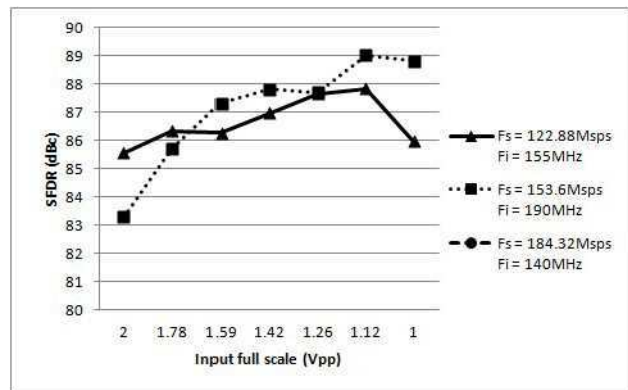
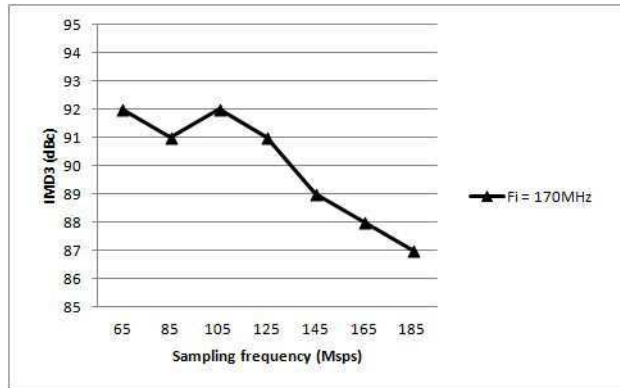
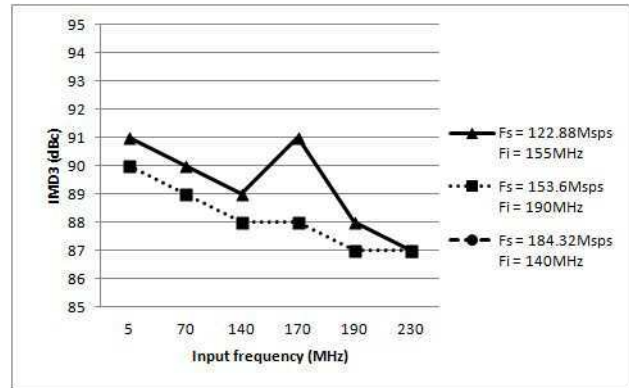

Fig 21. SFDR as a function of full-scale amplitude: -1 dBFS

## 10.3.5 Typical IMD3 performances



**Fig 22. IMD3 as a function of sampling frequency:**  
-7 dBFS;  $f_{i1} = 168.5$  MHz;  $f_{i2} = 171.5$  MHz



**Fig 23. IMD3 as a function of input frequency:**  
-7 dBFS; 3 MHz spacing

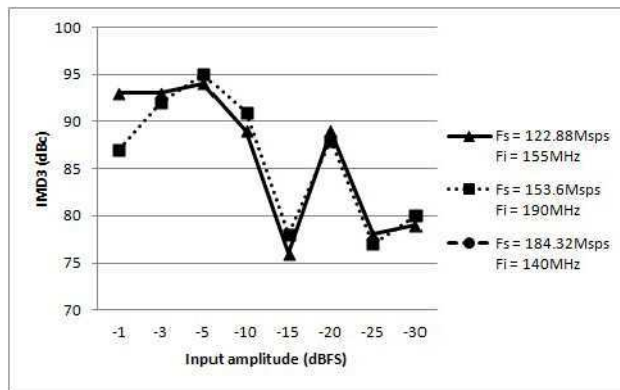

**Fig 24. IMD3 as a function of input amplitude:**  
3 MHz spacing;  $V_{I(dif)} = 2$  V

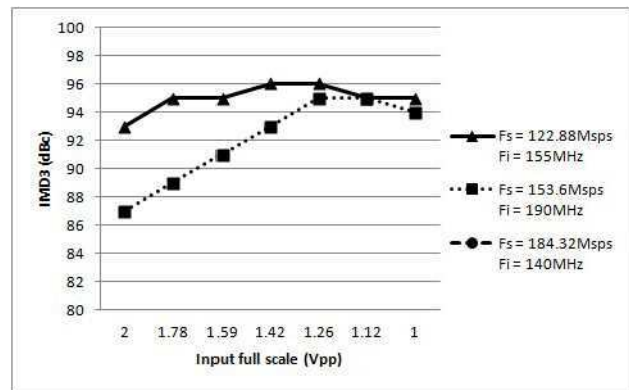

**Fig 25. IMD3 as a function of full-scale amplitude:**  
-7 dBFS; 3 MHz spacing

## 11. Application information

### 11.1 Analog inputs

#### 11.1.1 Input stage

The analog input of the ADC1443D supports a differential or a single-ended input drive. Optimal performance is achieved using differential inputs with respect to the common-mode input voltage ( $V_{I(cm)}$ ) on pins INP and INM.

The equivalent circuit of the sample and hold input stage, including ElectroStatic Discharge (ESD) protection and circuit and package parasitics, is shown in [Figure 26](#).

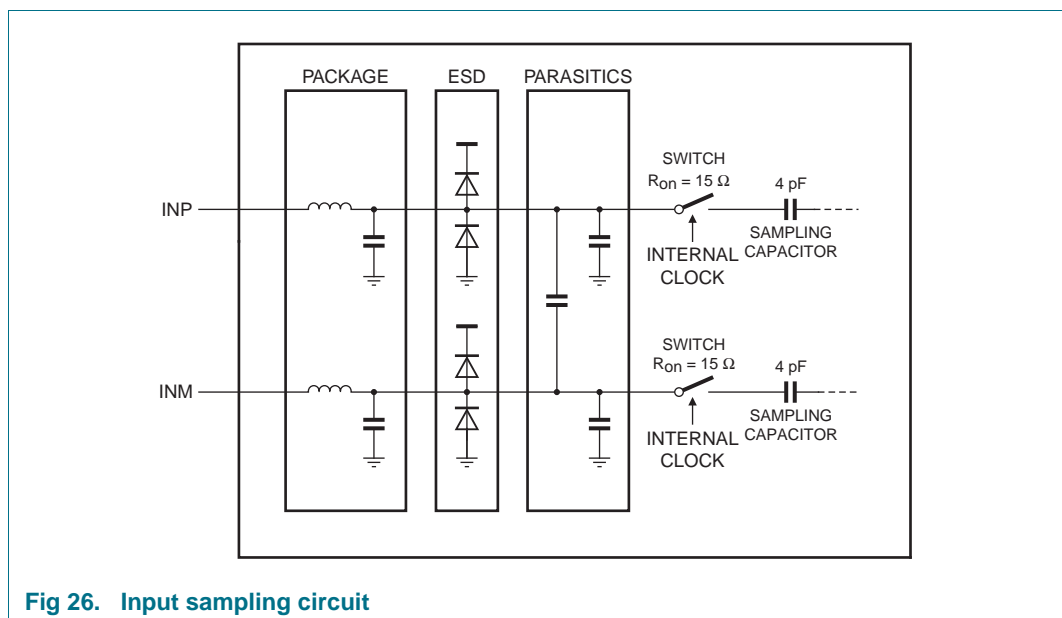

Fig 26. Input sampling circuit

The sample phase occurs when the internal sampling clock (derived from the clock signal on pin CLKP/CLKM) is HIGH. The voltage is then held on the sampling capacitors. When the sampling clock signal becomes LOW, the device enters the hold phase and the voltage information is transmitted to the ADC core.

#### 11.1.2 Common-mode input voltage ( $V_{I(cm)}$ )

Set the common-mode input voltage ( $V_{I(cm)}$ ) on pins INP and INM externally to 0.9 V for optimal performance.

#### 11.1.3 Pin VCM

When the input stage is AC-coupled, pin VCM can be used to set the common-mode reference for the analog inputs, for instance, via a transformer middle point. Connect a 0.1  $\mu$ F filter capacitor between pin VCM and ground to ensure a low-noise common-mode output voltage.

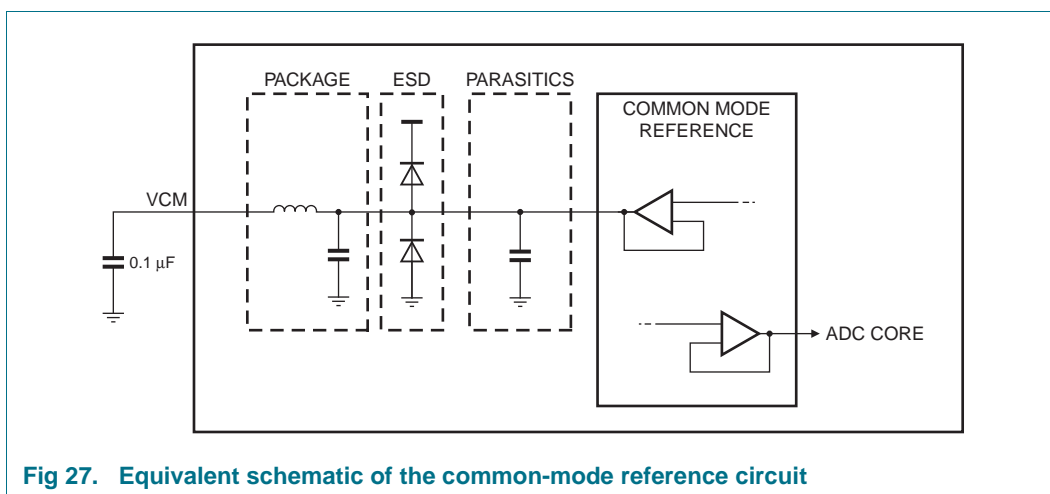

Fig 27. Equivalent schematic of the common-mode reference circuit

#### 11.1.4 Programmable full-scale

The full-scale analog input voltage range is configurable between 1 V (p-p) and 2 V (p-p) by programming internal reference gain between 0 dB and -6 dB in 1 dB steps. The full-scale range can be set independently via bits INTREF[2:0] of the SPI local registers (see [Table 10](#) and [Table 24](#)).

**Table 10. Reference gain control**

Default values are shown highlighted.

INTREF[2:0]	Level (dB)	Full-scale (V (p-p))
<b>000</b>	<b>0</b>	<b>2</b>
001	-1	1.78
010	-2	1.59
011	-3	1.42
100	-4	1.26
101	-5	1.12
110	-6	1
111	reserved	x

#### 11.1.5 Anti-kickback circuitry

An anti-kickback circuitry (RC-filter in [Figure 28](#)) is required to counteract the effects of the charge injection generated by the sampling capacitance.

The RC-filter is also used to filter noise from the signal before it reaches the sampling stage. It is recommended that the capacitor has a value that maximizes noise attenuation without degrading the settling time excessively.

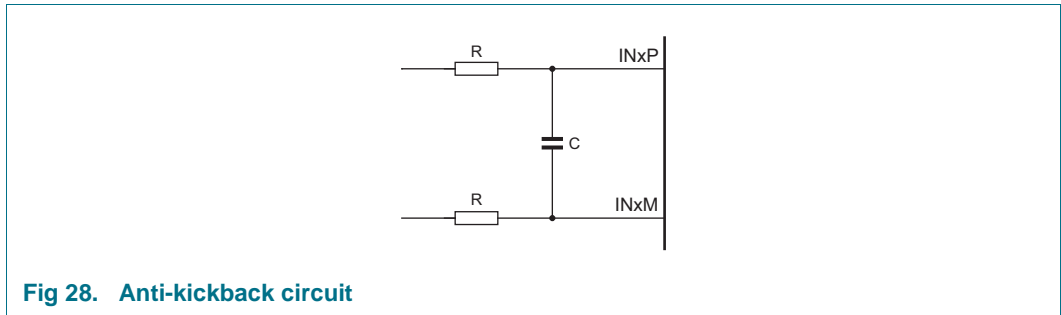

**Fig 28. Anti-kickback circuit**

The input frequency determines the component values. Select values that do not affect the input bandwidth. The value given in the following table are advised for 50Ω impedances system

**Table 11. RC coupling versus input frequency; typical values**

Input frequency range (MHz)	R (Ω)	C (pF)
0 to 50	25	12
50 to 200	10	3.9
200 to 300	6.8	3

### 11.1.6 Transformer

The input frequency determines the configuration of the transformer circuit. The configuration shown in [Figure 29](#) is suitable for a baseband application.

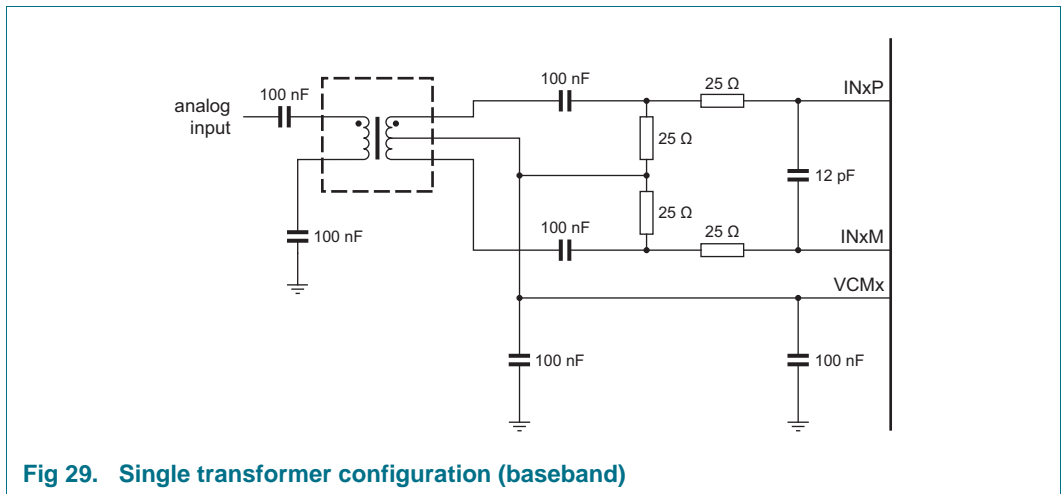

**Fig 29. Single transformer configuration (baseband)**

The configuration shown in [Figure 30](#) is recommended for high-frequency applications. In both cases, the choice of transformer is a compromise between cost and performance.

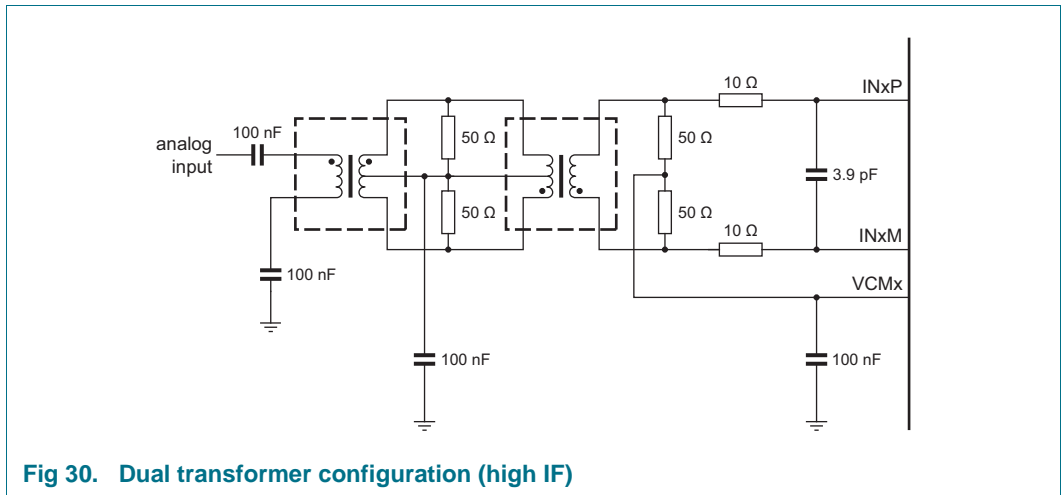

## 11.2 Clock input

### 11.2.1 Drive modes

The ADC1443D series can be driven differentially (LVPECL, LVDS or SINE). A single-ended LVCMOS signal connected to either pin CLKP or pin CLKM can also drive the device (connect the complementary pin to ground using a capacitor). The LVPECL is recommended for an optimal performance.

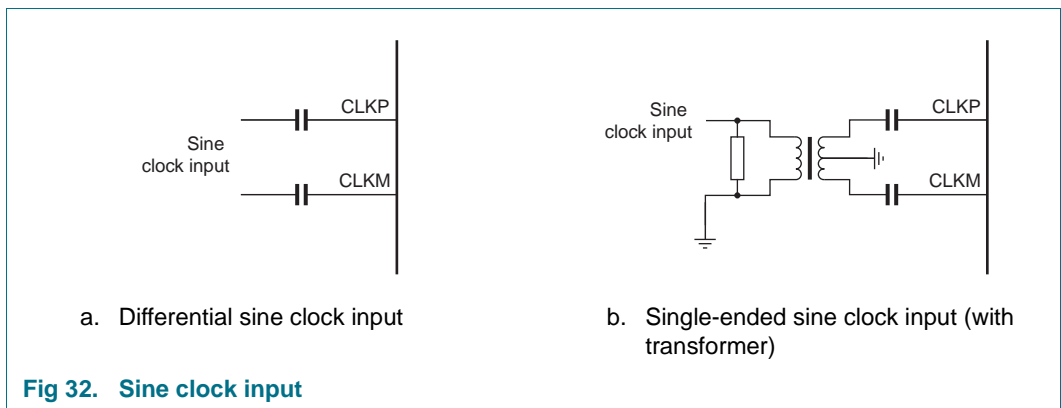
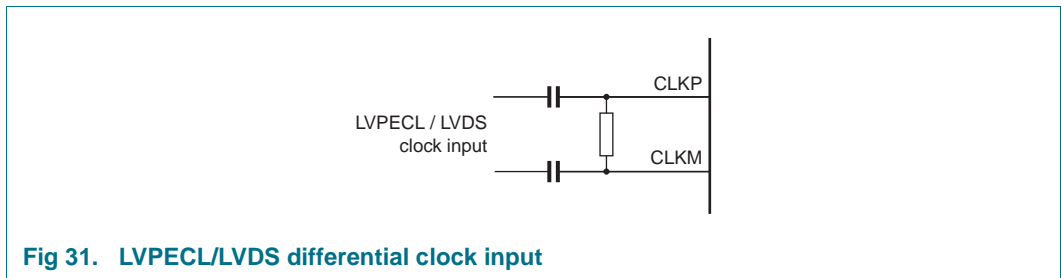

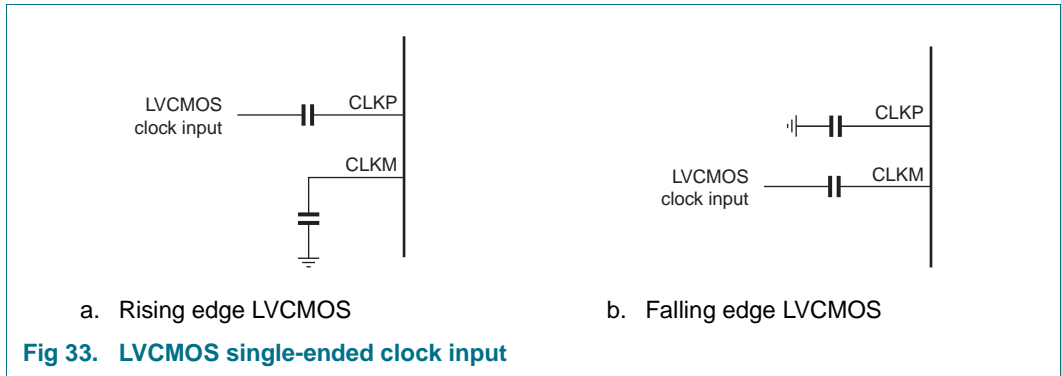

Single-ended or differential clock inputs can be selected via bit DIFF\_SE of SPI. If single-ended is enabled, the input pin (pin CLKM or pin CLKP) is selected using control bit SE\_SEL (see [Table 23](#)).

### 11.2.2 Equivalent input circuit

[Figure 34](#) shows the equivalent circuit of the input clock buffer. The input signal must be AC-coupled and the common-mode voltage of the differential input stage is set via internal 5 kΩ resistors.

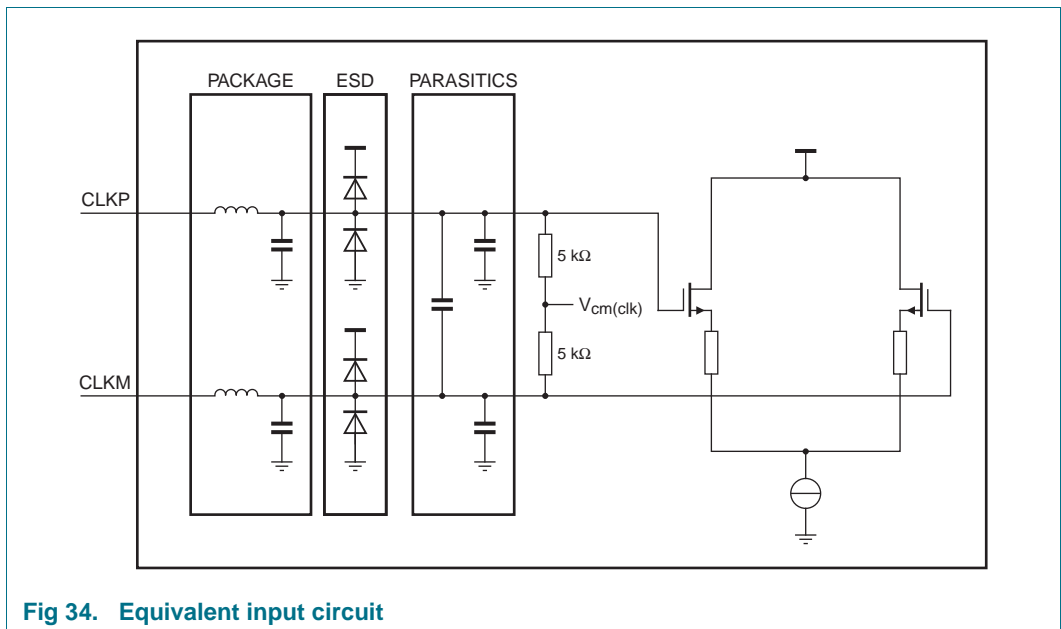

### 11.2.3 JESD204B harmonic clocking

The ADC1443D contains an input clock divider that divides the incoming clock (clock frequency fclk) by a factor of 1 to 8. The output of this divider is the sampling clock (sampling frequency fs) (see bits CLK\_DIV[1:0] in [Table 23](#)). This feature allows a higher clock frequency to be delivered to the ADC1443D and hence get a better jitter performance, leading to a better SNR result.

The ADC1443D should not be fed with a clock higher than 250Msps if the clock divider is not enabled, otherwise there is a risk of metastability.

Two options are allowed, either to program first the clock divider before enabling the Harmonic Clock, or to power-up the ADC1443 in « Power Down » mode by setting the CFG\_SETUP[3:0] to «1111» see [Table 16](#) , then program the clock divider to the wanted value and then «wake-up» the ADC using the SPI register IP\_CFG\_SETUP [Table 36](#), with the wanted configuration.

#### 11.2.4 JESD204B Deterministic Latency (pins SYSREFN and SYSREFP or SYNCBP and SYNCBN)

In the JESD204B standard 3 subclasses have been defined.

**Subclass 0:** No deterministic latency is required (equivalent to the JESD204A)

**Subclass 1:** Deterministic latency is wanted and is realized through the dedicated SYSREF pins.

The deterministic latency can be controlled with a single-ended or a differential SYSREF signal.

When SYSREF is active (High by default), it resets the clock divider phase registers. In a multi-device application and when the clock divider factor is higher than 1, the ADC1443D synchronization aligns all sampling clock edges (see [Table 8](#) and [Figure 4](#)).

On top of this, the SYSREF pins launch an internal LMFC counter ( Local Multi-frame counter), which has a period of a multi-frame  $F \cdot K$  (F: number of octets per frame, K: number of frames per multi-frame) see table [Table 16](#) for examples.

When a SYNC request occurs at SYNCBP/N , the ADC1443 will start the ILA sequence at an edge of the LMFC .

At the receiver side, the different lanes are aligned using the ILA and the ADC1443D releases the data at an LMFC boundary.

The receiver and the ADC1443D are now both starting an LMFC and ensuring an alignment based on this clock, which allow a deterministic latency.

**Subclass2 :** Behaviour is similar to Subclass1, but, instead of using a dedicated SYSREF signal, the SYNCBP/N is used for both SYNC request and deterministic latency.

The rising edge of the SYNCBP/N start the LMFC, while the falling edge set the SYNC request and hence start the Initial Lane Alignment according to the JEDEC JESD204B standard.

### 11.3 Digital outputs

#### 11.3.1 Digital output buffers

The JESD204A/JESD204B standard specifies that both the receiver and the transmitter must be provided by the same supply if they are connected in DC-coupling.

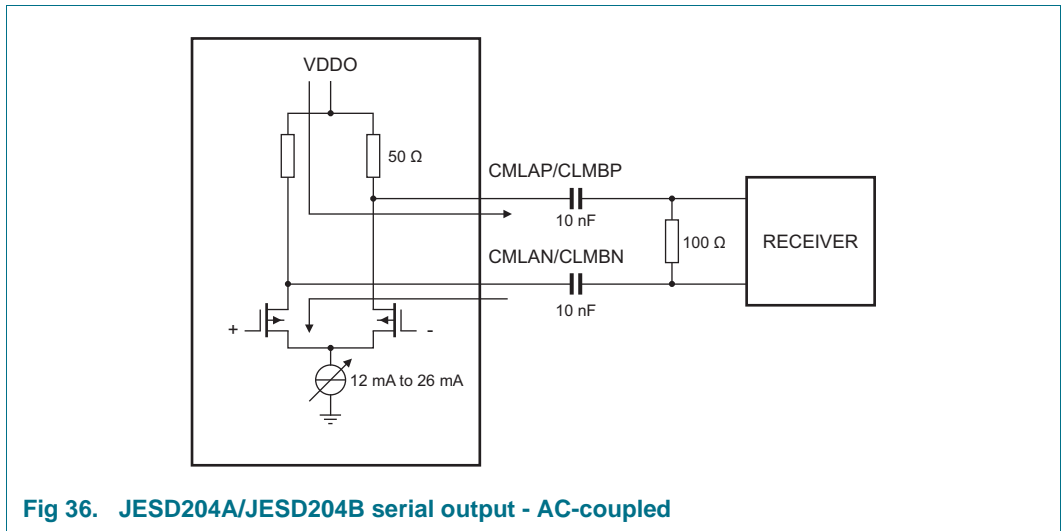
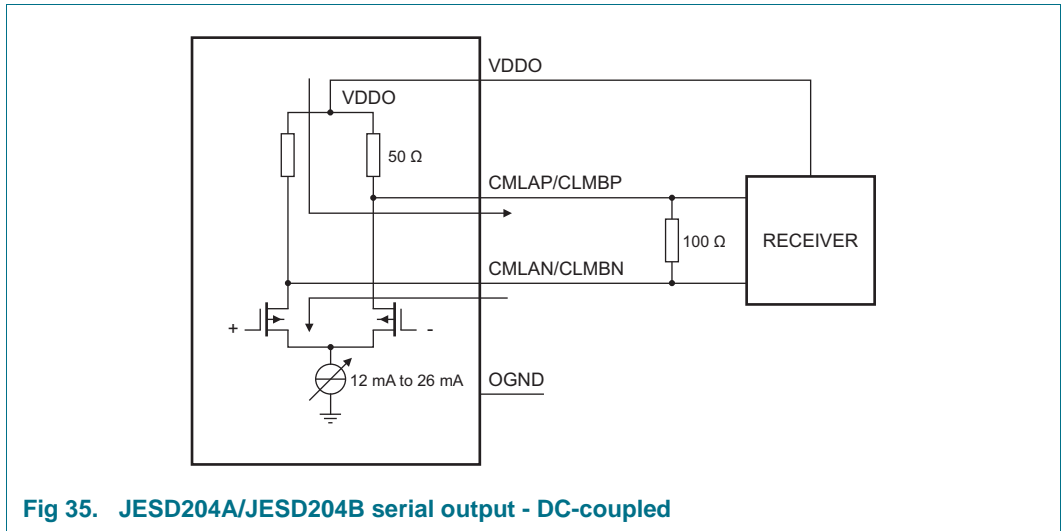

### 11.3.2 JESD204A/JESD204B serializer

#### 11.3.2.1 Digital JESD204A/JESD204B formatter

The block placed after the ADC1443D cores is used to implement all functionalities of the JESD204A/JESD204B standard. This ensures signal integrity and guarantees the clock and the data recovery at the receiver side.

The block is highly parameterized and can be configured in various ways depending on the sampling frequency and the number of lanes used.

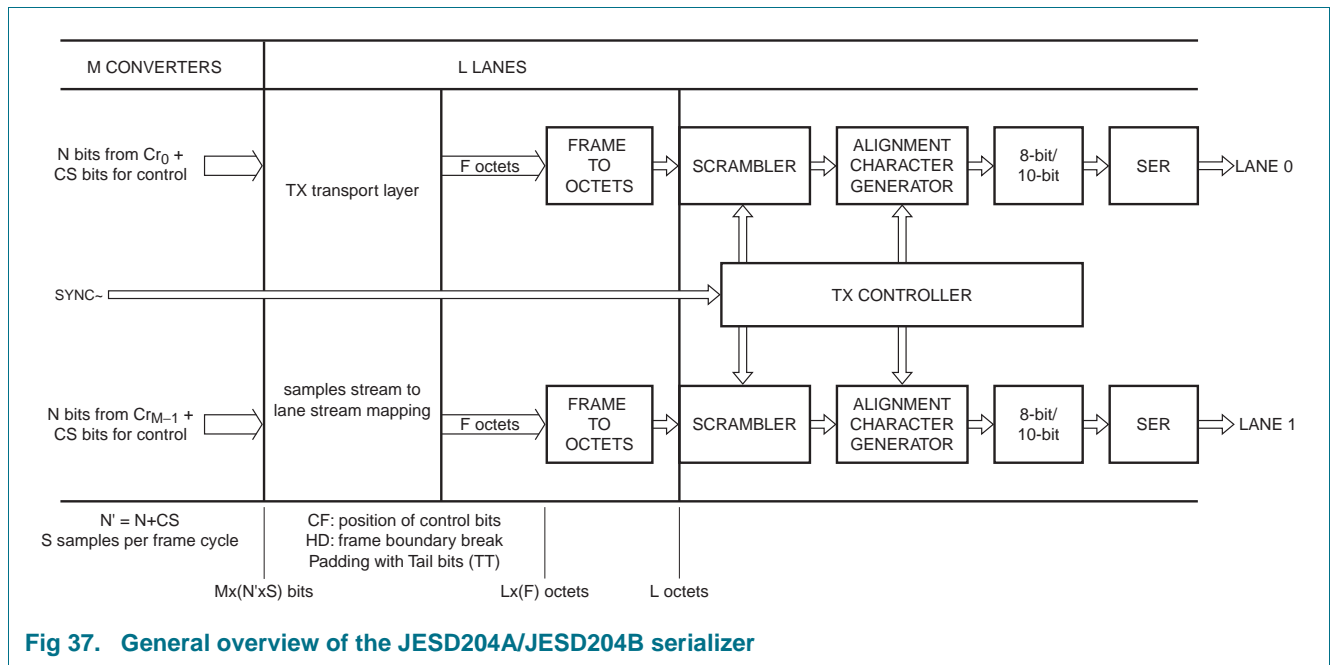

Fig 37. General overview of the JESD204A/JESD204B serializer

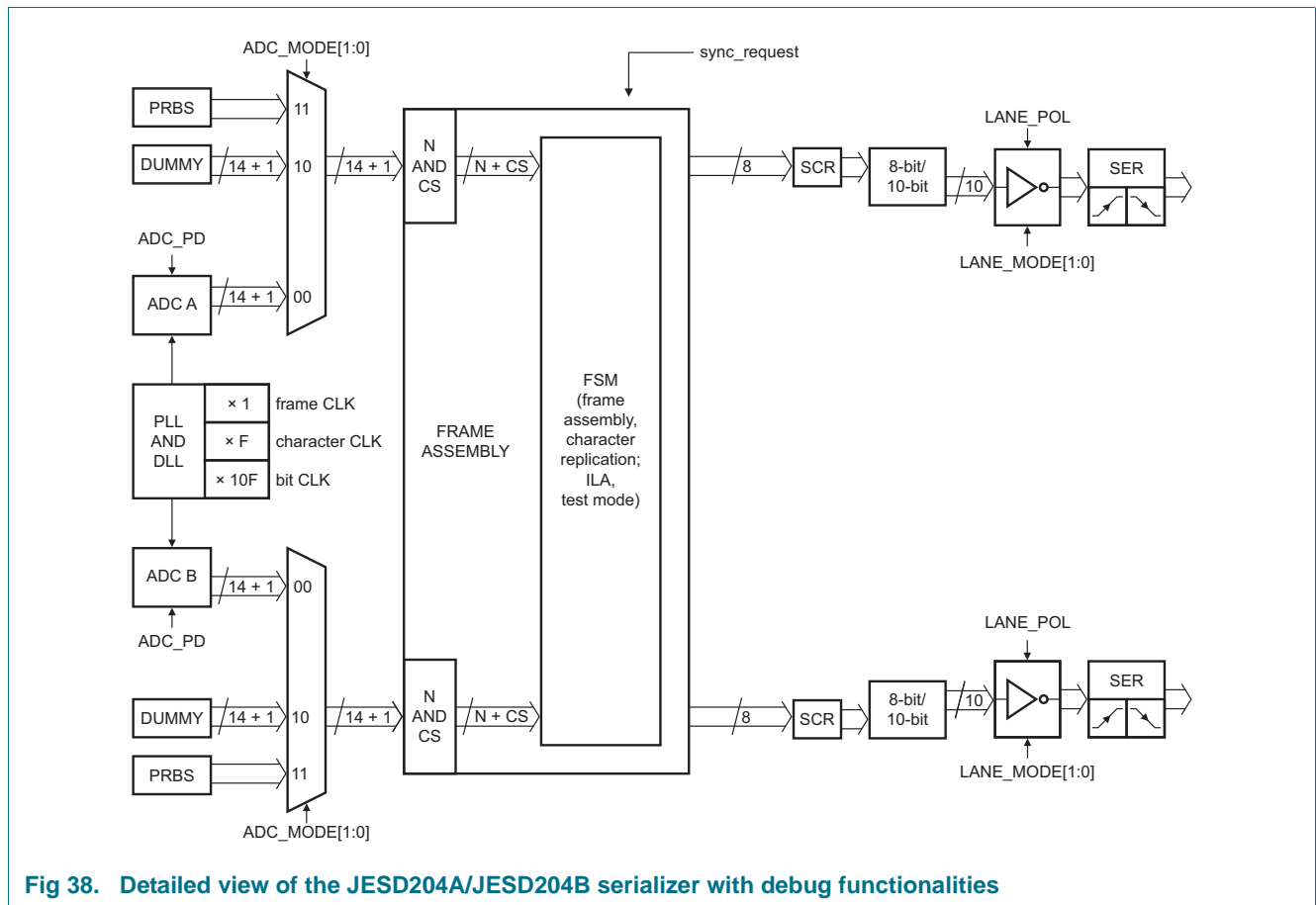

Fig 38. Detailed view of the JESD204A/JESD204B serializer with debug functionalities

### 11.3.3 OuT-of-Range (OTR)

An out-of-range signal is provided on pins OTRA and OTRAB.

The latency of OTR is 31 clock cycles. The OTR response can be speeded up by enabling fast OTR using SPI local registers (bit FAST\_OTR in [Table 31](#)). In this mode, the latency of OTR is reduced to only 11 clock cycles. The fast OTR detection threshold (below full-scale) can be programmed using the SPI local registers (bits FAST\_OTR\_DET[2:0] in [Table 31](#)).

**Table 12. Fast OTR register threshold**

FAST_OTR_DET[2:0]	Detection level (dB)
000	-18.06
001	-14.54
010	-12.04
011	-8.52
<b>100</b>	<b>-6.02</b>
101	-4.08
110	-2.5
111	-1.16

### 11.3.4 Digital offset

By default, the ADC1443D delivers an output code that corresponds to the analog input. However, it is possible to add a digital offset to the output code using the SPI local registers (bits DIG\_OFFSET[5:0] in see [Table 13](#) and [Table 27](#)). The digital offset adjustment is coded in two's complement.

**Table 13. Digital offset adjustment**

*Default values are shown highlighted.*

DIG_OFFSET[5:0]	Digital offset adjustment (LSB)
10 0000	-32
10 0001	-31
...	...
11 1111	-1
<b>00 0000</b>	<b>0</b>
00 0001	+1
...	...
01 1110	+30
01 1111	+31

### 11.3.5 Test patterns

The ADC1443D can be configured to transmit a number of predefined test patterns using the SPI local registers (bits TEST\_PAT\_SEL[2:0] in [Table 14](#) and [Table 28](#)). The selected test pattern is transmitted regardless of the analog input.

**Table 14. Digital test pattern selection**

Default values are shown highlighted.

TEST_PAT_SEL[2:0]	Digital test pattern
<b>000</b>	<b>Off</b>
001	Mid code
010	Min code
011	Max code
100	Toggle '1111..1111'/'0000..0000'
101	Custom test pattern
110	'0101..0101'
111	'1010..1010'

A custom test pattern can be defined using the SPI local registers (bits TEST\_PAT\_USER[13:6] in [Table 29](#) and bits TEST\_PAT\_USER[5:0] in [Table 30](#)).

### 11.3.6 Output data format selection

The ADC1443D output data format can be selected (offset binary, two's complement or gray code) using the SPI local registers (bits DATA\_FORMAT[1:0] in [Table 26](#)).

### 11.3.7 Output codes versus input voltage

**Table 15. Output codes**

$V_{INP} - V_{INM}$	Offset binary	Two's complement	Gray code	OTR
< -1	00 0000 0000 0000	10 0000 0000 0000	00 0000 0000 0000	1
-1	00 0000 0000 0000	10 0000 0000 0000	00 0000 0000 0000	0
-0.99987793	00 0000 0000 0001	10 0000 0000 0001	00 0000 0000 0001	0
-0.99975586	00 0000 0000 0010	00 0000 0000 0010	00 0000 0000 0011	0
...	...	...	...	0
-0.00024414	01 1111 1111 1110	11 1111 1111 1110	01 0000 0000 0001	0
-0.00012207	01 1111 1111 1111	11 1111 1111 1111	01 0000 0000 0000	0
+0.00012207	10 0000 0000 0000	00 0000 0000 0000	11 0000 0000 0000	0
+0.0.00024414	10 0000 0000 0001	00 0000 0000 0001	11 0000 0000 0001	0
...	...	...	...	0
+0.99975586	11 1111 1111 1101	01 1111 1111 1101	10 0000 0000 0011	0
+0.99987793	11 1111 1111 1110	01 1111 1111 1110	10 0000 0000 0001	0
+1	11 1111 1111 1111	01 1111 1111 1111	10 0000 0000 0000	0
> +1	11 1111 1111 1111	01 1111 1111 1111	10 0000 0000 0000	1

### 11.4 Configuration pins (CFG0, CFG1, CFG2, CFG3)

The configuration pins are only active as inputs at start-up. The values on those pins are read once to set up the device. Then the pins become outputs (OTRA and OTRB). SPI applies any change in the configuration.

N.B: for harmonic clocking uses, the CFG pins must be set to «1111», to start the ADC in power down mode and hence avoid any issue that comes from delivering a high frequency clock before setting the clock division.

Table 16. JESD204A/JESD204B configuration table

CFG_SETUP[3:0]	ADC A	ADC B	Lane 0	Lane 1	F <sup>[1]</sup>	HD <sup>[1]</sup>	K <sup>[1]</sup>	M <sup>[1]</sup>	L <sup>[1]</sup>	Comment	CS <sup>[1]</sup>	CF <sup>[1]</sup>	S <sup>[1]</sup>
0 0000	ON	ON	ON	ON	2	0	9	2	2	$(F \times K) \geq 17$	1	0	1
1 0001	ON	ON	ON	OFF	4	0	5	2	1	$(F \times K) \geq 17$	1	0	1
2 0010	ON	ON	OFF	ON	4	0	5	2	1	$(F \times K) \geq 17$	1	0	1
3 0011	reserved												
4 0100	reserved												
5 0101	ON	OFF	ON	OFF	2	0	9	1	1	$(F \times K) \geq 17$	1	0	1
6 0110	ON	OFF	OFF	ON	2	0	9	1	1	$(F \times K) \geq 17$	1	0	1
7 0111	OFF	ON	ON	OFF	2	0	9	1	1	$(F \times K) \geq 17$	1	0	1
8 1000	OFF	ON	OFF	ON	2	0	9	1	1	$(F \times K) \geq 17$	1	0	1
9 1001	ON	OFF	ON	ON	1	1	17	1	2	$(F \times K) \geq 17$	1	0	1
10 1010	OFF	ON	ON	ON	1	1	17	1	2	$(F \times K) \geq 17$	1	0	1

Table 16. JESD204A/JESD204B configuration table ...continued

CFG_SETUP[3:0]	ADC A	ADC B	Lane 0	Lane 1	F <sup>[1]</sup>	HD <sup>[1]</sup>	K <sup>[1]</sup>	M <sup>[1]</sup>	L <sup>[1]</sup>	Comment	CS <sup>[1]</sup>	CF <sup>[1]</sup>	S <sup>[1]</sup>	
11	1011									reserved				
12	1100									reserved				
13	1101									reserved				
14	1110									reserved				
15	1111	OFF	OFF	OFF	OFF	2	0	9	2	2	chip power-down	1	0	1

- [1] F: Octets per frame clock cycle  
 HD: High-density mode  
 K: Frame per multi-frame  
 M: Converters per device  
 L: Lane per converter device  
 CS: Number of control bits per conversion sample  
 CF: Control words per frame clock cycle and link  
 S: Number of samples transmitted per single converter per frame cycle

## 11.5 Serial Peripheral Interface (SPI)

### 11.5.1 Register description

The ADC1443D serial interface is a synchronous serial communications port, which allows easy interfacing with many commonly used microprocessors. It provides access to the registers controlling the operation of the chip.

The register bits are either global or local functions:

- A global function operates over the full IC behavior. A local function operates on one or several previously selected channels only. If a channel is selected, the next WRITE command in the local registers applies to the selected channel. The WRITE command has no impact on channels that are not selected. This makes it possible to apply different configurations on each channel by first selecting a specific channel and then all the related settings.
- Select only one channel during a READ operation of the local registers. If several channels are selected, the READ operation occurs on the channel A.

Programming all registers at the same time is required:

- The IC allows the storage of a set of settings for the addresses 06h to 23h, which enables the configuration of all registers simultaneously by setting bit TRANSFER to HIGH (see [Table 33](#)). This bit is autoclearing. This function can be disabled using SPI (bit TRANS\_DIS in [Table 33](#)). The registers are then updated at each WRITE operation.
- The transfer function does not apply to a READ operation.

The SPI interface is configured as a 3-wire type: pin SDIO is the bidirectional pin, pin SCLK is the serial clock input and SCS\_N is the chip select pin.

A LOW level on pin SCS\_N initiates each READ/WRITE operation. A minimum of 3 bytes is transmitted (two instruction bytes and at least 1 DATA byte; see [Table 18](#)).

**Table 17. Instruction bytes for the SPI**

Bit:	7 (MSB)	6	5	4	3	2	1	0 (LSB)
Description	R/ $\overline{W}$	W1	W0	A12	A11	A10	A9	A8
	A7	A6	A5	A4	A3	A2	A1	A0

- Bit R/ $\overline{W}$  indicates whether it is a READ (when HIGH) or a WRITE (when LOW) operation.
- Bits W1 and W0 indicate the number of bytes to be transferred after both instruction bytes (see [Table 18](#)).

**Table 18. Number of data bytes transferred**

W1	W0	Number of bytes transferred
0	0	1 byte
0	1	2 bytes
1	0	3 bytes
1	1	4 or more bytes

- Bits A12 to A0 indicate the address of the register being accessed. If it concerns a multiple byte transfer, this address is the first register accessed. An address counter is increased to access subsequent addresses.

The steps for a data transfer are:

1. Communication starts with the first rising edge on pin SCLK after a falling edge on pin SCS\_N.
2. The first phase is the transfer of the 2-byte instruction.
3. The second phase is the transfer of the data. Its length varies, but it is always a multiple of 8 bits. The MSB is always sent first (for instruction and data bytes).
4. A rising edge on pin SCS\_N indicates the end on data transmission.

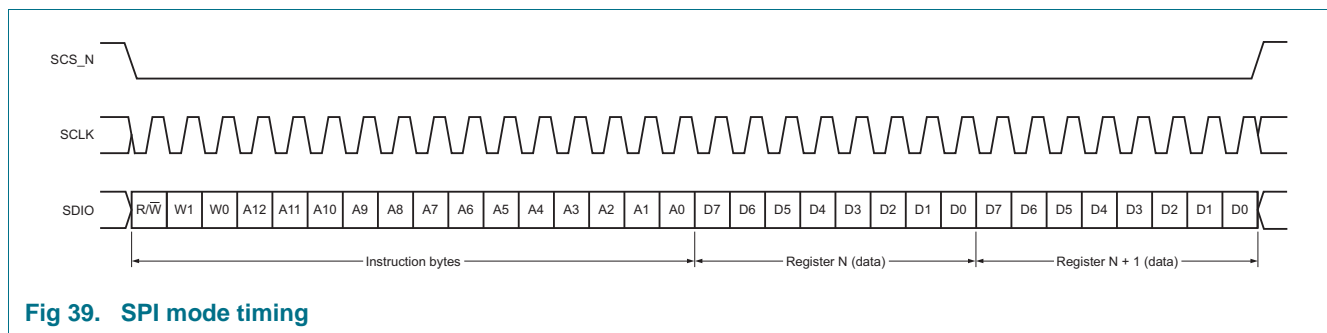

**Fig 39. SPI mode timing**

## 11.5.2 Register allocation map

Table 19 shows an overview of all registers.

Table 19. Register allocation map

Addr. (hex)	Register name	R/W	Bit definition								Default
			Bit 7	Bit 6	Bit 5	Bit 4	Bit 3	Bit 2	Bit 1	Bit 0	
<b>ADC control registers</b>											
0000h	CHIP_RST	RW	SW_RST[7:0]								0000 0000
0001h	CHIP_ID	R	CHIP_ID[7:0] <sup>[1]</sup>								0100 0011
0005h	CHIP_RST	R/W	SW_RST	-	-	-	-	-	-	-	0000 0000
0006h	OP_MODE <sup>[2]</sup>	R/W	-	-	-	-	-	-	OP_MODE[1:0] <sup>[3]</sup>		0000 0000
0007h	CLK_CFG	R/W	-	-	-	SE_SEL	DIFF_SE	CLK_DIV[2:0]		0000 0000	
0008h	INTERNAL_REF	R/W	-	-	-	-	-	INTREF[2:0]		0000 0000	
0009h	CHANNEL_SEL	R/W	-	-	-	-	-	-	ADC_B	ADC_A	0000 1111
0011h	OUTPUT_CFG	R/W	-	-	-	-	-	DATA_SWAP	DATA_FORMAT[1:0]		0000 0000
0013h	DIG_OFFSET	R/W	DIG_OFFSET[5:0]						-	-	0000 0000
0014h	TEST_CFG_1	R/W	-	-	-	-	-	TEST_PAT_SEL[2:0]		0000 0000	
0015h	TEST_CFG_2	R/W	TEST_PAT_USER[13:6]								0000 0000
0016h	TEST_CFG_3	R/W	TEST_PAT_USER[5:0]						-	-	0000 0000
0017h	OTR_CFG	R/W	-	-	-	RESERVED	FAST_OTR	FAST_OTR_DET[2:0]		0001 0100	
0043h	DCS_CTRL	R/W	-	SYSREF_SE	-	-	-	-	DIV_RESET_POL	DIV_RESE T_SEL	11000100
00FFh	TRANS_CFG	R/W	TRANS_DIS	TRANSFER	-	-	-	-	-	-	0000 0000
<b>JESD204A/JESD204B control</b>											
0801h	IP_STATUS	R	RXSYNC_ERR_FLG	RESERVED[5:0]						PLL_LOCK	0000 0000
0802h	IP_RST	R/W	SW_RST	-	-	-	ASSEMBLER_SW_RST	-	-	-	0000 0000
0803h	IP_CFG_SETUP	R/W	-	-	-	-	CFG_STP[3:0]			0000 ****	

Table 19. Register allocation map ...continued

Addr. (hex)	Register name	R/W	Bit definition								Default	
			Bit 7	Bit 6	Bit 5	Bit 4	Bit 3	Bit 2	Bit 1	Bit 0		
0805h	IP_CTRL1	R/W	RESERVED	TRISTATE_CFG_PAD	SYNC_POL	SYNC_SE	EN_RXSYNC_ERR	RESERVED[2:0]			0000 0000	
0806h	IP_CTRL2	R/W	RESERVED[5:0]					SWP_LANE_1_2	SWP_ADC_0_1			0000 ****
080Bh	IP_PRBS_CTRL	R/W	RESERVED[5:0]					PRBS_TYPE[1:0]			0000 0000	
0810h	JESD204B_CTRL1	R/W	LMFC_periodic_rst	LMFC_reset_en	-	-	-	-	-	-	0000 0000	
0811h	JESD204B_CTRL2	R/W	DCS_periodic_rst	DCS_reset_en	-	-	-	-	-	-	0000 0000	
0812h	JESD204B_CTRL3	R/W	-	-	-	-	sync_at_lmfc_en	-	sync_capture_path	-	0000 0000	
0816h	IP_DEBUG_OUT1	R/W	-	-	-	-	-	-	PAT_OUT[9:8]		0000 0010	
0817h	IP_DEBUG_OUT2	R/W	PAT_OUT[7:0]								1010 1010	
0818h	IP_DEBUG_IN1	R/W	PAT_IN[15:8]								1010 1010	
0819h	IP_DEBUG_IN2	R/W	PAT_IN[7:0]								0000 0010	
081Bh	IP_TESTMODE	R/W	RESERVED	LOOP_ALIGN	DIS_REPL_CHAR	BYP_ALIGN	RESERVED[3:0]				0*00 0000	
081Ch	IP_EXPERT_DOOR	R/W	KEY[7:0]								0000 0000	
081Eh	SYSREF_CFG	R/W	-	-	-	-	-	SYSREF_EN	SYSREF_SE	-	0000 0000	
0822h	CFG_3_SCR_L	R/W	SCR[0]	RESERVED[5:0]					L[0]		0000 0000(?)	
086Bh	OUTBUF00_SWING	R/W	RESERVED[4:0]				SWING[3:0]				0000 01**	
086Ch	OUTBUF03_SWING	R/W	SWING_SPARE[2:0]				SWING[3:0]				0000 01**	

Table 19. Register allocation map ...continued

Addr. (hex)	Register name	R/W	Bit definition							Default
			Bit 7	Bit 6	Bit 5	Bit 4	Bit 3	Bit 2	Bit 1	
0871h	LANE00_0_CTRL	R/W	RESERVED[2:0]			LANE_MODE[1:0]	LANE_POL	RESERVED	LANE_PD	0000 000*
0872h	LANE01_0_CTRL	R/W	RESERVED[2:0]			LANE_MODE[1:0]	LANE_POL	RESERVED	LANE_PD	0000 000*
0890h	ADC00_0_CTRL	R/W	-	-	ADC_MODE[1:0]	-	-	-	ADC_PD	0000 0000
0891h	ADC01_0_CTRL	R/W	-	-	ADC_MODE[1:0]	-	-	-	ADC_PD	0000 0000

[1] The READ-ONLY and RESERVED registers.

[2] The registers influenced by the TRANSFER function.

[3] The LOCAL registers.

### 11.5.3 Detailed register description

The tables in this section contain detailed descriptions of the registers.

#### 11.5.3.1 ADC control registers

**Table 20. CHIP\_RESET register (address 0000h) bit description**

Default settings are shown highlighted.

Bit	Symbol	Access	Value	Description
7 to 0	SW_RST	R/W	-	resets global and local registers for any value “1” written at any bit (autoclear).

**Table 21. CHIP\_RESET register (address 0005h) bit description**

Default settings are shown highlighted.

Bit	Symbol	Access	Value	Description
7	SW_RST	R/W		resets global and local registers
			<b>0</b>	<b>no reset</b>
			1	performs a reset to the default values (autoclear)
6 to 0	-	-	-	not used

**Table 22. OP\_MODE register (address 0006h) bit description**

Default settings are shown highlighted.

Bit	Symbol	Access	Value	Description
7 to 2	-	-	-	not used
1 to 0	OP_MODE[1:0] <sup>[1]</sup>	R/W		operating mode for the selected channel
			<b>00</b>	<b>normal (power-up)</b>
			01	power-down
			10	sleep
			11	not used

[1] Local register.

**Table 23. CLK\_CFG register (address 0007h) bit description**

Default settings are shown highlighted.

Bit	Symbol	Access	Value	Description
7 to 5	-	-	-	not used
4	SE_SEL	R/W		single-ended clock input pin selection
			<b>0</b>	<b>CLKP</b>
			1	CLKM
3	DIFF_SE	R/W		differential/single-ended clock input selection
			<b>0</b>	<b>fully differential</b>
			1	single-ended

**Table 23. CLK\_CFG register (address 0007h) bit description ...continued**

Default settings are shown highlighted.

Bit	Symbol	Access	Value	Description
2 to 0	CLK_DIV[1:0]	R/W		clock divider selection
			<b>000</b>	<b>divide by 1</b>
			001	divide by 2
			010	divide by 3
			011	divide by 4
			100	divide by 5
			101	divide by 6
			110	divide by 7
			111	divide by 8

**Table 24. INTERNAL\_REF register (address 0008h) bit description**

Default settings are shown highlighted.

Bit	Symbol	Access	Value	Description
7 to 3	-	-	-	not used
2 to 0	INTREF[2:0] <sup>[1]</sup>	R/W	-	see <a href="#">Table 10</a>

[1] Local register

**Table 25. CHANNEL\_SEL register (address 0009h) bit description**

Default settings are shown highlighted.

Bit	Symbol	Access	Value	Description
7 to 2	-	-	-	not used
1	ADC_B	R/W		channel B selection for next SPI operation in local registers
			0	not selected
			<b>1</b>	<b>selected</b>
0	ADC_A	R/W		channel A selection for next SPI operation in local registers
			0	not selected
			<b>1</b>	<b>selected</b>

**Table 26. OUTPUT\_CFG register (address 0011h) bit description**

Default settings are shown highlighted.

Bit	Symbol	Access	Value	Description
7 to 3	-	-	-	not used
2	DATA_SWAP <sup>[1]</sup>	R/W		output data bits swapped
			<b>0</b>	<b>no swapping</b>
			1	MSBs swapped with LSBs

**Table 26. OUTPUT\_CFG register (address 0011h) bit description ...continued**

Default settings are shown highlighted.

Bit	Symbol	Access	Value	Description
1 to 0	DATA_FORMAT[1:0] <sup>[1]</sup>	R/W		output data format
			<b>00</b>	<b>offset binary</b>
			01	two's complement
			10	gray code
			11	offset binary

[1] Local register

**Table 27. DIG\_OFFSET register (address 0013h) bit description**

Default settings are shown highlighted.

Bit	Symbol	Access	Value	Description
7 to 2	DIG_OFFSET[7:0] <sup>[1]</sup>	R/W	-	see <a href="#">Table 13</a>
1 to 0	-	-	-	not used

[1] Local register

**Table 28. TEST\_CFG\_1 register (address 0014h) bit description**

Default settings are shown highlighted.

Bit	Symbol	Access	Value	Description
7 to 3	-	-	-	not used
2 to 0	TEST_PAT_SEL[2:0] <sup>[1]</sup>	R/W	-	see <a href="#">Table 14</a>

[1] Local register

**Table 29. TEST\_CFG\_2 register (address 0015h) bit description**

Default settings are shown highlighted.

Bit	Symbol	Access	Value	Description
7 to 0	TEST_PAT_USER[13:6] <sup>[1]</sup>	R/W	-	custom digital test pattern (bits 13 to 6)

[1] Local register

**Table 30. TEST\_CFG\_3 register (address 0016h) bit description**

Default settings are shown highlighted.

Bit	Symbol	Access	Value	Description
7 to 2	TEST_PAT_USER[5:0] <sup>[1]</sup>	R/W	-	custom digital test pattern (bits 5 to 0)
1 to 0	-	-	-	not used

[1] Local register

**Table 31. OTR\_CFG register (address 0017h) bit description**

Default settings are shown highlighted.

Bit	Symbol	Access	Value	Description
7 to 5	-	-	-	not used
4	RESERVED	R/W	1	reserved

**Table 31. OTR\_CFG register (address 0017h) bit description ...continued**

Default settings are shown highlighted.

Bit	Symbol	Access	Value	Description
3	FAST_OTR <sup>[1]</sup>	R/W		Selection OTR full-scale/ fast OTR
			0	OTR full-scale
			<b>1</b>	<b>fast OTR</b>
2 to 0	FAST_OTR_DET[2:0] <sup>[1]</sup>	R/W	-	

[1] Local register

**Table 32. DCS\_CTRL register (address 0043h) bit description**

Default settings are shown highlighted.

Bit	Symbol	Access	Value	Description
7	-	-	1	not used, set allways to 1
6	-	-	1	not used, set allways to 1
5 to 2	-	-	-	not used
1	DIV_RESET_POL	R/W		Polarity of the DCS reset
			1	Rising edge ( Subclass 1 )
			<b>0</b>	falling edge ( Subclass 2 )
0	DIV_RESET_SEL	R/W		DCS reset selection
			0	SYNCBP/N is used (Subclass2)
			<b>1</b>	SYSREFP/N is used (Subclass1)

[1] Local register

**Table 33. TRANS\_CFG register (address 00FFh) bit description**

Default settings are shown highlighted.

Bit	Symbol	Access	Value	Description
7	TRANS_DIS	R/W		disable transfer function
			<b>0</b>	<b>transfer function active</b>
			1	registers updated on a WRITE command
6	TRANSFER	R/W		updates the registers with the written settings
			<b>0</b>	<b>settings are stored</b>
			1	registers updated (autoclear)
5 to 0	-	-	-	not used

## 11.5.3.2 JESD204A/JESD204B control registers

Table 34. IP\_STATUS register (address 0801h) bit description

Default settings are shown highlighted.

Bit	Symbol	Access	Value	Description
7	RXSYNC_ERR_FLG	R	0	RX synchronization error 0: no error 1: synchronization error has occurred
6 to 1	RESERVED[5:0]	R	000000	reserved
0	PLL_LOCK	R	0	JEDEC PLL lock 0: unlocked 1: locked

Table 35. IP\_RESET register (address 0802h) bit description

Default settings are shown highlighted.

Bit	Symbol	Access	Value	Description
7	SW_RST	R/W	0	software reset: All JESD subblocks and registers are reset
6 to 4	-	-	000	not used
3	ASSEMBLER_SW_RST	R/W	0	Only the RXSYNC_ERR_FLG register bit and the frame assembler subblock are reset
2 to 0	-	-	000	not used

Table 36. IP\_CFG\_SETUP register (address 0803h) bit description

Default settings are shown highlighted.

Bit	Symbol	Access	Value	Description
7 to 4	-	-	0000	not used
3 to 0	CFG_SETUP[3:0]	R/W	****	see <a href="#">Table 38</a>

Table 37. Serial frequency computation information

CFG_SETUP	ADC sampling frequency (Mbps)	Lane 0 serial frequency (Gbps)	Lane 1 serial frequency (Gbps)
0000	FS	20 × FS	20 × FS
0001	FS	40 × FS	0
0010	FS	0	40 × FS
0011		reserved	
0100		reserved	
0101	FS	20 × FS	0
0110	FS	0	20 × FS
0111	FS	20 × FS	0
1000	FS	0	20 × FS
1001	FS	10 × FS	10 × FS
1010	FS	10 × FS	10 × FS
1011		reserved	
1100		reserved	

Table 37. Serial frequency computation information

CFG_SETUP	ADC sampling frequency (Mbps)	Lane 0 serial frequency (Gbps)	Lane 1 serial frequency (Gbps)
1101		reserved	
1110		reserved	
1111	FS	0	0

Table 38. JESD204A/JESD204B configuration table

CFG_SETUP[3:0]	ADC[0]	ADC[1]	Lane 0	Lane 1	F <sup>[1]</sup>	HD <sup>[1]</sup>	K <sup>[1]</sup>	M <sup>[1]</sup>	L <sup>[1]</sup>	Comment	CS <sup>[1]</sup>	CF <sup>[1]</sup>	S <sup>[1]</sup>
0 0000	ON	ON	ON	ON	2	0	9	2	2	(F × K) ≥ 17	1	0	1
1 0001	ON	ON	ON	OFF	4	0	5	2	1	(F × K) ≥ 17	1	0	1
2 0010	ON	ON	OFF	ON	4	0	5	2	1	(F × K) ≥ 17	1	0	1
3 0011										reserved			
4 0100										reserved			
5 0101	ON	OFF	ON	OFF	2	0	9	1	1	(F × K) ≥ 17	1	0	1
6 0110	ON	OFF	OFF	ON	2	0	9	1	1	(F × K) ≥ 17	1	0	1
7 0111	OFF	ON	ON	OFF	2	0	9	1	1	(F × K) ≥ 17	1	0	1
8 1000	OFF	ON	OFF	ON	2	0	9	1	1	(F × K) ≥ 17	1	0	1
9 1001	ON	OFF	ON	ON	1	1	17	1	2	(F × K) ≥ 17	1	0	1
10 1010	OFF	ON	ON	ON	1	1	17	1	2	(F × K) ≥ 17	1	0	1
11 1011										reserved			
12 1100										reserved			
13 1101										reserved			
14 1110										reserved			
15 1111	OFF	OFF	OFF	OFF	2	0	9	2	2	chip power-down	1	0	1

[1] F: Octets per frame clock cycle

HD: High-density mode

K: Frame per multi-frame

M: Converters per device

L: Lane per converter device

CS: Number of control bits per conversion sample

CF: Control words per frame clock cycle and link

S: Number of samples transmitted per single converter per frame cycle

Table 39. IP\_CTRL1 register (address 0805h) bit description

Default settings are shown highlighted.

Bit	Symbol	Access	Value	Description
7	RESERVED	R/W	0	reserved
6	TRISTATE_CFG_PAD	R/W	(1 > 0)	TriState configuration pad 0: CFG Pads in Output mode (debug feature) 1: CFG Pads in Input mode; operating at power-up (see <a href="#">Table 38</a> )

**Table 39. IP\_CTRL1 register (address 0805h) bit description ...continued**

Default settings are shown highlighted.

Bit	Symbol	Access	Value	Description
5	SYNC_POL	R/W	0	synchronization polarity 0: default synchronization polarity used (active LOW) 1: polarity inversion (active HIGH)
4	SYNC_SE	R/W	0	single-ended synchronization 0: differential synchronization 1: single-ended synchronization
3	EN_RXSYNC_ERR	R/W	1	error reporting using synchronization interface 0: disabled 1: enabled
2 to 0	RESERVED	R/W	001	reserved

**Table 40. IP\_CTRL2 register (address 0806h) bit description**

Default settings are shown highlighted.

Bit	Symbol	Access	Value	Description
7 to 2	RESERVED	R/W	0000**	reserved
1	SWP_LANE_1_2	R/W	*	swap lanes: if set to logic 1 the lanes are swapped symmetrically (L0 ↔ L1, L1 ↔ L0)
0	SWP_ADC_0_1	R/W	*	if set to logic 1, ADC 0 and ADC1 are swapped at the input of the frame assembler

**Table 41. IP\_PRBS\_CTRL register (address 080Bh) bit description**

Default settings are shown highlighted.

Bit	Symbol	Access	Value	Description
7 to 2	RESERVED	-	000000	reserved
1 to 0	PRBS_TYPE[1:0]	R/W	00	defines the type of Pseudo-Random Binary Sequence (PRBS) generator to be used 00; PRBS-7; $1 + x^6 + x^1$ 10; PRBS-23; $1 + x^{18} + x^{23}$

**Table 42. JESD204B\_CTRL1 register (address 0810h) bit description**

Default settings are shown highlighted.

Bit	Symbol	Access	Value	Description
7	LMFC_periodic_rst	R/W	0	defines the LMFC modes 0; LMFC reset is done once 1; LMFC reset is done at each SYSREF or SYNC
6	LMFC_periodic_rst	R/W	0	enables the LMFC reset 0; LMFC reset is disabled 1; LMFC reset is enabled
5 to 0	-	-	00000	reserved

**Table 43. JESD204B\_CTRL2 register (address 0811h) bit description***Default settings are shown highlighted.*

Bit	Symbol	Access	Value	Description
7	DCS_periodic_rst	R/W	0	defines the LMFC modes 0;DCS reset is done once 1; DCS reset is done at each SYSREF or SYNC
6	DCS_periodic_rst	R/W	0	enables the LMFC reset 0;DCS reset is disabled 1; DCS reset is enabled
5 to 0	-	-	00000	reserved

**Table 44. JESD204B\_CTRL3 register (address 0812h) bit description***Default settings are shown highlighted.*

Bit	Symbol	Access	Value	Description
7 to 4	-	-	0000	reserved
3	sync_at_lmfc_en	R/W	0	define the relation between the SYNC and the LMFC 0;SYNC is fetched directly (JESD204A mode) 1; SYNC is taken at next LMFC boundary ( Subclass 1 and Subclass 2)
2	-	-	0	reserved
1	sync_capture_path	R/W	0	SYNC mode 0;JESD204A mode 1; Subclass 1 and Subclass 2
0	-	-	0	reserved

**Table 45. IP\_DEBUG\_OUT1 register (address 0816h) bit description***Default settings are shown highlighted.*

Bit	Symbol	Access	Value	Description
7 to 2	-	-	000000	not used
1 to 0	PATTERN_OUT[9:8]	R/W	10	2 most significant bits of output stage debug word (inserted just before serializer)

**Table 46. IP\_DEBUG\_OUT2 register (address 0817h) bit description***Default settings are shown highlighted.*

Bit	Symbol	Access	Value	Description
7 to 0	PATTERN_OUT[7:0]	R/W	1010 1010	8 least significant bits of output stage debug word (inserted just before serializer)

**Table 47. IP\_DEBUG\_IN1 register (address 0818h) bit description***Default settings are shown highlighted.*

Bit	Symbol	Access	Value	Description
7 to 0	PATTERN_IN[15:8]	R/W	1010 1010	8 most significant bits of input stage debug word (inserted in place of ADC data)

**Table 48. IP\_DEBUG\_IN2 register (address 0819h) bit description**

Default settings are shown highlighted.

Bit	Symbol	Access	Value	Description
7 to 0	PATTERN_IN[7:0]	R/W	0000 0010	8 least significant bits of input stage debug word (inserted in place of ADC data)

**Table 49. IP\_TESTMODE register (address 081Bh) bit description**

Default settings are shown highlighted.

Bit	Symbol	Access	Value	Description
7	RESERVED	R/W	0	reserved
6	LOOP_ALIGN	R/W	*[1]	ILA sequence is repeated infinitely
5	DIS_REPL_CHAR	R/W	0	no replacement character is placed in the data flow
4	BYP_ALIGN	R/W	0	ILA is bypassed
3 to 0	RESERVED	R/W	0000	reserved

[1] ILA = Initial Lane Alignment Sequence (see JESD204 JEDEC standard).

**Table 50. IP\_EXPERT\_DOOR register (address 081Ch) bit description**

Default settings are shown highlighted.

Bit	Symbol	Access	Value	Description
7	KEY[7:0]	R/W	0000 0000	8-bit key to enable Write access for JESD204 control register

**Table 51. SYSREF\_CFG register (address 081Eh) bit description**

Default settings are shown highlighted.

Bit	Symbol	Access	Value	Description
7 to 4	RESERVED	R/W	0000	reserved
3	SYSREF_EN	R/W	0	1 : Enable SYSREFP/N path 0 : Disable SYSREFP/N path
2	SYSREF_SE			1 : SYSREFP is used as single ended SYSREF input 0 : SYSREFP/SYREFN are used as differential pair
1 to 0	RESERVED	R/W	00	reserved

**Table 52. CFG\_3\_SCR\_L register (address 0822h) bit description**

Default settings are shown highlighted.

Bit	Symbol	Access	Value	Description
7	SCR[0]	R/W	0	scrambling enabler
6 to 1	RESERVED	R/W	000000	reserved
0	L[0]	R/W	0	lanes number minus 1 (for example, for two lanes L = 1)  0x4A must be written in the IP_EXPERT_DOOR registers to obtain write access to this register

**Table 53. IP\_OUTBUF00\_SWING register (address 086Bh) bit description**

Default settings are shown highlighted.

Bit	Symbol	Access	Value	Description
7 to 3	RESERVED[4:0]	R/W	00000	reserved
2 to 0	SWING[2:0]	R/W		Configurable lane 0 output current
			000	12 mA; $\pm 300$ mV (p-p)
			001	14 mA; $\pm 350$ mV (p-p)
			010	16 mA; $\pm 400$ mV (p-p)
			011	18 mA; $\pm 450$ mV (p-p)
			100	20 mA; $\pm 500$ mV (p-p)
			<b>101</b>	<b>22 mA; <math>\pm 550</math> mV (p-p)</b>
			110	24 mA; $\pm 600$ mV (p-p)
			111	26 mA; $\pm 650$ mV (p-p)

**Table 54. IP\_OUTBUF01\_SWING register (address 086Ch) bit description**

Default settings are shown highlighted.

Bit	Symbol	Access	Value	Description
7 to 3	RESERVED[4:0]	R/W	00000	reserved
2 to 0	SWING[2:0]	R/W		Configurable lane 1 output current
			000	12 mA; $\pm 300$ mV (p-p)
			001	14 mA; $\pm 350$ mV (p-p)
			010	16 mA; $\pm 400$ mV (p-p)
			011	18 mA; $\pm 450$ mV (p-p)
			100	20 mA; $\pm 500$ mV (p-p)
			<b>101</b>	<b>22 mA; <math>\pm 550</math> mV (p-p)</b>
			110	24 mA; $\pm 600$ mV (p-p)
			111	26 mA; $\pm 650$ mV (p-p)

**Table 55. IP\_LANE00\_0\_CTRL register (address 0871h) bit description**

Default settings are shown highlighted.

Bit	Symbol	Access	Value	Description
7 to 5	RESERVED[2:0]	R/W	000	reserved
4 to 3	LANE_MODE[1:0]	R/W	00	debug option directly before serializer 0: normal mode, ADC path 1: toggle (0/1 toggle sent over the lanes) 2: A constant (value in IP_DEBUG_OUT) is sent over the lanes 3: PRBS polynom is sent over the lane
2	LANE_POL	R/W	0	if set to logic 1, lane P/N polarity is inverted
1	RESERVED	R/W	0	reserved
0	LANE_PD	R/W	*	if set to logic 1, lane enters power-down

**Table 56. IP\_LANE01\_0\_CTRL register (address 0872h) bit description***Default settings are shown highlighted.*

Bit	Symbol	Access	Value	Description
7 to 5	RESERVED[2:0]	R/W	000	reserved
4 to 3	LANE_MODE[1:0]	R/W	00	debug option directly before serializer 0: normal mode, ADC path 1: toggle (0/1 toggle sent over the lanes) 2: A constant (value in IP_DEBUG_OUT) is sent over the lanes 3: PRBS polynom is sent over the lane
2	LANE_POL	R/W	0	if set to logic 1, lane P/N polarity is inverted
1	RESERVED	R/W	0	reserved
0	LANE_PD	R/W	*	if set to logic 1, lane enters power-down

**Table 57. IP\_ADC00\_0\_CTRL register (address 0890h) bit description***Default settings are shown highlighted.*

Bit	Symbol	Access	Value	Description
7 to 6	RESERVED	R/W	00	reserved
5 to 4	ADC_MODE[1:0]	R/W	00	debug option to replace ADC core 0, 1: normal mode, ADC path 2: a constant (value in IP_Debug_in) is sent instead of ADC conversion output 3: PRBS polynom is sent instead of ADC
3 to 1	RESERVED	R/W	000	reserved
0	ADC_PD	R/W	0	if set to logic 1, ADC enters power-down

**Table 58. IP\_ADC01\_0\_CTRL register (address 0891h) bit description***Default settings are shown highlighted.*

Bit	Symbol	Access	Value	Description
7 to 6	RESERVED	R/W	00	reserved
5 to 4	ADC_MODE[1:0]	R/W	00	debug option to replace ADC core 0, 1: normal mode, ADC path 2: a constant (value in IP_Debug_in) is sent instead of ADC conversion output 3: PRBS polynom is sent instead of ADC
3 to 1	RESERVED	R/W	000	reserved
0	ADC_PD	R/W	0	if set to logic 1, ADC enters power-down

12. Package outline

HLQFN56R: plastic thermal enhanced low profile quad flat package; no leads; 56 terminals; resin based; body 8 x 8 x 1.35 mm

SOT935-2

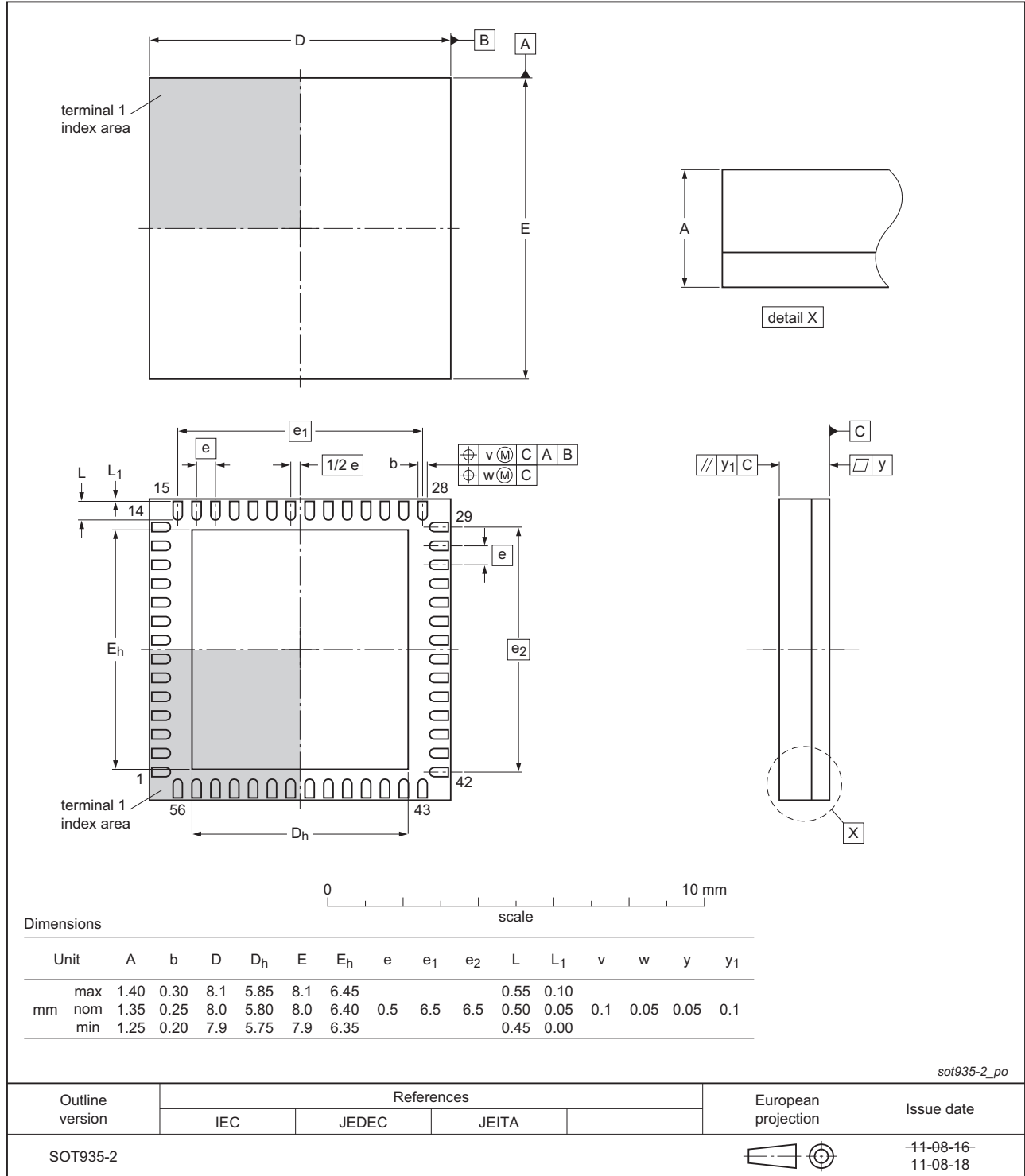

Fig 40. Package outline SOT935-2 (HLQFN56)

## 13. Abbreviations

**Table 59. Abbreviations**

Acronym	Description
ADC	Analog-to-Digital Converter
CDMA	Code Division Multiple Access
DAV	DAta Valid
ESD	ElectroStatic Discharge
FFT	Fast Fourier Transform
GSM	Global System for Mobile communications
ILA	Initial Lane Alignment
IMD3	third order InterMoDulation product
LSB	Least Significant Bit
LTE	Long-Term Evolution
LVDS DDR	Low Voltage Differential Signaling Double Data Rate
LVPECL	Low-Voltage Positive Emitter-Coupled Logic
MIMO	Multiple Input Multiple Output
MSB	Most Significant Bit
OTR	OuT-of-Range
SFDR	Spurious-Free Dynamic Range
SPI	Serial Peripheral Interface
SNR	Signal-to-Noise Ratio
TD-SCDMA	Time Division-Synchronous Code Division Multiple Access
WCDMA	Wideband Code Division Multiple Access
WiMAX	Worldwide interoperability for Microwave Access

## 14. Revision history

Table 60. Revision history

Document ID	Release date	Data sheet status	Change notice	Supersedes
ADC1443D_SER v.3.4	20121010	Data sheet	-	ADC1443D_SER v.3.3
ADC1443D_SER v.3.3	20120926	Objective data sheet	-	ADC1443D_SER v.3.2
ADC1443D_SER v.3.2	20120918	Objective data sheet	-	ADC1443D_SER v.3.1
ADC1443D_SER v.3.1	20120911	Objective data sheet	-	ADC1443D_SER v.3.0
ADC1443D_SER v.3.0	<tbd>	Objective data sheet	-	ADC1443D_SER v.2.0
Modifications:	<ul style="list-style-type: none"> <li>• Text and drawings updated throughout entire data sheet.</li> </ul>			
ADC1443D_SER v.2.0	20120630	Objective data sheet	-	ADC1443D_SER v.1.1
ADC1443_SER v.1.1	20110928	Objective data sheet	-	ADC1443D_SER v.1
ADC1443D_SER v.1	20110901	Objective data sheet	-	-

## Contact information



[www.IDT.com](http://www.IDT.com)

6024 Silver Creek Valley Road  
San Jose, California 95138

## 15. Contents

<b>1</b>	<b>General description</b> . . . . .	<b>1</b>	11.3.1	Digital output buffers . . . . .	24
<b>2</b>	<b>Features and benefits</b> . . . . .	<b>1</b>	11.3.2	JESD204A/JESD204B serializer . . . . .	25
<b>3</b>	<b>Applications</b> . . . . .	<b>2</b>	11.3.2.1	Digital JESD204A/JESD204B formatter . . . . .	25
<b>4</b>	<b>Ordering information</b> . . . . .	<b>2</b>	11.3.3	Out-of-Range (OTR) . . . . .	27
<b>5</b>	<b>Block diagram</b> . . . . .	<b>3</b>	11.3.4	Digital offset . . . . .	27
<b>6</b>	<b>Pinning information</b> . . . . .	<b>4</b>	11.3.5	Test patterns . . . . .	28
6.1	Pinning . . . . .	4	11.3.6	Output data format selection . . . . .	28
6.2	Pin description . . . . .	5	11.3.7	Output codes versus input voltage . . . . .	28
<b>7</b>	<b>Limiting values</b> . . . . .	<b>7</b>	11.4	Configuration pins (CFG0, CFG1, CFG2, CFG3) 29	
<b>8</b>	<b>Thermal characteristics</b> . . . . .	<b>7</b>	11.5	Serial Peripheral Interface (SPI) . . . . .	30
<b>9</b>	<b>Static characteristics</b> . . . . .	<b>7</b>	11.5.1	Register description . . . . .	30
<b>10</b>	<b>Dynamic characteristics</b> . . . . .	<b>10</b>	11.5.2	Register allocation map . . . . .	32
10.1	Dynamic characteristics . . . . .	10	11.5.3	Detailed register description . . . . .	35
10.2	Timing . . . . .	12	11.5.3.1	ADC control registers . . . . .	35
10.2.1	Clock timing . . . . .	12	11.5.3.2	JESD204A/JESD204B control registers . . . . .	39
10.2.2	SYSREF timing . . . . .	13	<b>12</b>	<b>Package outline</b> . . . . .	<b>46</b>
10.2.3	SPI timing . . . . .	13	<b>13</b>	<b>Abbreviations</b> . . . . .	<b>47</b>
10.3	Typical dynamic performances . . . . .	14	<b>14</b>	<b>Revision history</b> . . . . .	<b>48</b>
10.3.1	Typical FFT at 122.88 Msps . . . . .	14	<b>15</b>	<b>Contents</b> . . . . .	<b>49</b>
10.3.2	Typical FFT at 153.6 Msps . . . . .	15			
10.3.3	Typical SNR performances . . . . .	16			
10.3.4	Typical SFDR performances . . . . .	17			
10.3.5	Typical IMD3 performances . . . . .	18			
<b>11</b>	<b>Application information</b> . . . . .	<b>19</b>			
11.1	Analog inputs . . . . .	19			
11.1.1	Input stage . . . . .	19			
11.1.2	Common-mode input voltage ( $V_{I(cm)}$ ) . . . . .	19			
11.1.3	Pin VCM . . . . .	19			
11.1.4	Programmable full-scale . . . . .	20			
11.1.5	Anti-kickback circuitry . . . . .	20			
11.1.6	Transformer . . . . .	21			
11.2	Clock input . . . . .	22			
11.2.1	Drive modes . . . . .	22			
11.2.2	Equivalent input circuit . . . . .	23			
11.2.3	JESD204B harmonic clocking . . . . .	23			
11.2.4	JESD204B Deterministic Latency (pins SYSREFN and SYSREFP or SYNCBP and SYNCBN) . . . . .	24			
11.3	Digital outputs . . . . .	24			

### Disclaimer

Integrated Device Technology, Inc. (IDT) and its subsidiaries reserve the right to modify the products and/or specifications described herein at any time and at IDT's sole discretion. All information in this document, including descriptions of product features and performance, is subject to change without notice. Performance specifications and the operating parameters of the described products are determined in the independent state and are not guaranteed to perform the same way when installed in customer products. The information contained herein is provided without representation or warranty of any kind, whether express or implied, including, but not limited to, the suitability of IDT's products for any particular purpose, an implied warranty of merchantability, or non-infringement of the intellectual property rights of others. This document is presented only as a guide and does not convey any license under intellectual property rights of IDT or any third parties.

IDT's products are not intended for use in life support systems or similar devices where the failure or malfunction of an IDT product can be reasonably expected to significantly affect the health or safety of users. Anyone using an IDT product in such a manner does so at their own risk, absent an express, written agreement by IDT.

Integrated Device Technology, IDT and the IDT logo are registered trademarks of IDT. Other trademarks and service marks used herein, including protected names, logos and designs, are the property of IDT or their respective third party owners.

Copyright, 2012. All rights reserved.

