



3.3V CMOS 16-BIT BUS TRANSCEIVER WITH 3-STATE OUTPUTS, 5 VOLT TOLERANT I/O

IDT74LVC16245A

FEATURES:

- Typical $t_{sk(o)}$ (Output Skew) < 250ps
- ESD > 2000V per MIL-STD-883, Method 3015; > 200V using machine model (C = 200pF, R = 0)
- $V_{cc} = 3.3V \pm 0.3V$, Normal Range
- $V_{cc} = 2.7V$ to $3.6V$, Extended Range
- CMOS power levels (0.4 μ W typ. static)
- All inputs, outputs, and I/O are 5V tolerant
- Supports hot insertion
- Available in SSOP, TSSOP, and TVSOP packages

DRIVE FEATURES:

- High Output Drivers: $\pm 24mA$
- Reduced system switching noise

APPLICATIONS:

- 5V and 3.3V mixed voltage systems
- Data communication and telecommunication systems

DESCRIPTION:

This 16-bit bus transceiver is built using advanced dual metal CMOS technology. This high-speed, low power transceiver is ideal for asynchronous communication between two busses (A and B). The Direction and Output Enable controls are designed to operate this device as either two independent 8-bit transceivers or one 16-bit transceiver. The direction control pin (DIR) controls the direction of data flow. The output enable pin (\overline{OE}) overrides the direction control and disables both ports. All inputs are designed with hysteresis for improved noise margin.

All pins can be driven from either 3.3V or 5V devices. This feature allows the use of this device as a translator in a mixed 3.3V/5V supply system.

The LVC16245A has been designed with a $\pm 24mA$ output driver. This driver is capable of driving a moderate to heavy load while maintaining speed performance.

FUNCTIONAL BLOCK DIAGRAM

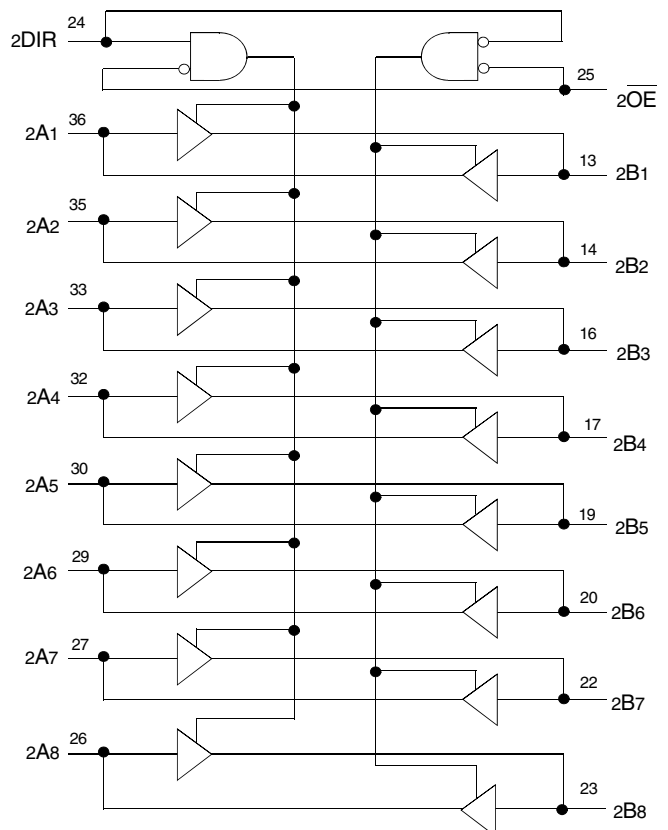
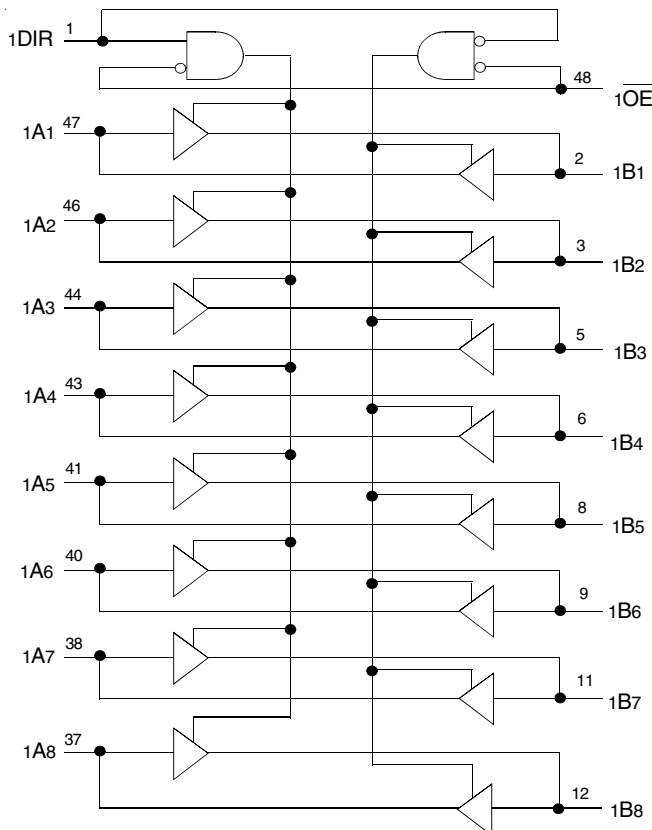

The IDT logo is a registered trademark of Integrated Device Technology, Inc.

INDUSTRIAL TEMPERATURE RANGE

JUNE 2006

PIN CONFIGURATION

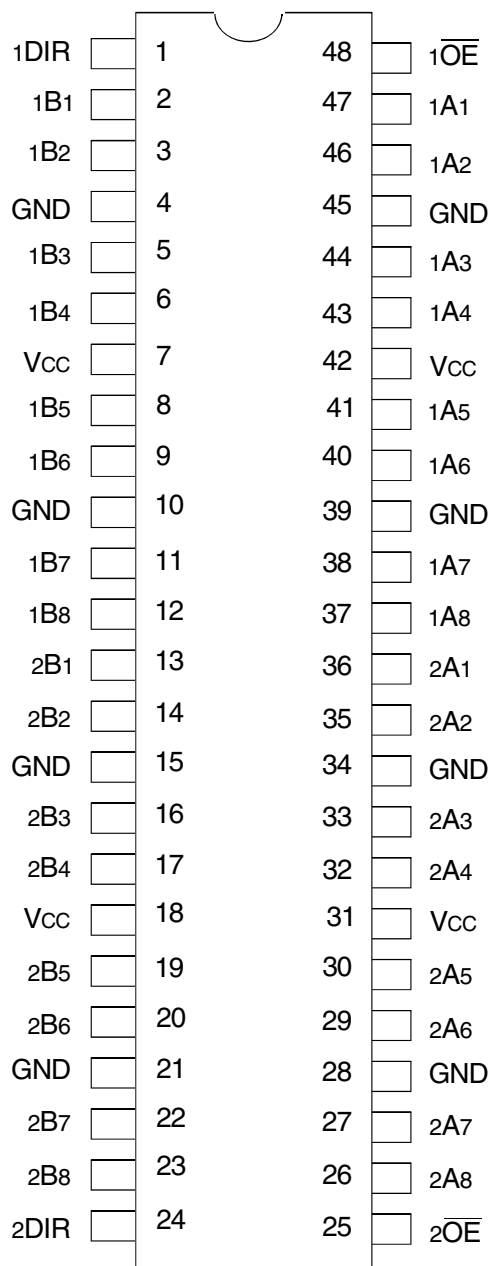

SSOP/ TSSOP/ TVSOP
TOP VIEW

ABSOLUTE MAXIMUM RATINGS⁽¹⁾

| Symbol | Description | Max | Unit |
|------------------------------------|---|--------------|------|
| VTERM ⁽²⁾ | Terminal Voltage with Respect to GND | -0.5 to +6.5 | V |
| VTERM ⁽³⁾ | Terminal Voltage with Respect to GND | -0.5 to +6.5 | V |
| TSTG | Storage Temperature | -65 to +150 | °C |
| IOUT | DC Output Current | -50 to +50 | mA |
| I _{IK} I _{OK} | Continuous Clamp Current, V _I < 0 or V _O < 0 | -50 | mA |
| I _{CC} I _{SS} | Continuous Current through each V _{CC} or GND | ±100 | mA |

NOTES:

- Stresses greater than those listed under ABSOLUTE MAXIMUM RATINGS may cause permanent damage to the device. This is a stress rating only and functional operation of the device at these or any other conditions above those indicated in the operational sections of this specification is not implied. Exposure to absolute maximum rating conditions for extended periods may affect reliability.
- V_{CC} terminals.
- All terminals except V_{CC}.

CAPACITANCE (T_A = +25°C, F = 1.0MHz)

| Symbol | Parameter ⁽¹⁾ | Conditions | Typ. | Max. | Unit |
|------------------|--------------------------|-----------------------|------|------|------|
| C _{IN} | Input Capacitance | V _{IN} = 0V | 4.5 | 6 | pF |
| C _{OUT} | Output Capacitance | V _{OUT} = 0V | 6.5 | 8 | pF |
| C _{I/O} | I/O Port Capacitance | V _{IN} = 0V | 6.5 | 8 | pF |

NOTE:

- As applicable to the device type.

PIN DESCRIPTION

| Pin Names | Description |
|-------------------|-----------------------------------|
| x \overline{OE} | Output Enable Inputs (Active LOW) |
| xDIR | Direction Control Input |
| xAx | Side A Inputs or 3-State Outputs |
| xBx | Side B Inputs or 3-State Outputs |

FUNCTION TABLE (EACH 8-BIT SECTION)⁽¹⁾

| Inputs | | Outputs |
|-------------------|------|---------------------|
| x \overline{OE} | xDIR | |
| L | L | Bus B Data to Bus A |
| L | H | Bus A Data to Bus B |
| H | X | Z |

NOTES:

- H = HIGH Voltage Level
X = Don't Care
L = LOW Voltage Level
Z = High-Impedance

DC ELECTRICAL CHARACTERISTICS OVER OPERATING RANGE

Following Conditions Apply Unless Otherwise Specified:

Operating Condition: $T_A = -40^{\circ}\text{C}$ to $+85^{\circ}\text{C}$

| Symbol | Parameter | Test Conditions | | Min. | Typ. ⁽¹⁾ | Max. | Unit |
|--|--|---|---|------|---------------------|------|------|
| V _{IH} | Input HIGH Voltage Level | V _{CC} = 2.3V to 2.7V | | 1.7 | — | — | V |
| | | V _{CC} = 2.7V to 3.6V | | 2 | — | — | |
| V _{IL} | Input LOW Voltage Level | V _{CC} = 2.3V to 2.7V | | — | — | 0.7 | V |
| | | V _{CC} = 2.7V to 3.6V | | — | — | 0.8 | |
| I _{IH} I _{IL} | Input Leakage Current | V _{CC} = 3.6V | V _I = 0 to 5.5V | — | — | ±5 | μA |
| I _{OZH} I _{OZL} | High Impedance Output Current (3-State Output pins) | V _{CC} = 3.6V | V _O = 0 to 5.5V | — | — | ±10 | μA |
| I _{OFF} | Input/Output Power Off Leakage | V _{CC} = 0V, V _{IN} or V _O ≤ 5.5V | | — | — | ±50 | μA |
| V _{IK} | Clamp Diode Voltage | V _{CC} = 2.3V, I _{IN} = -18mA | | — | -0.7 | -1.2 | V |
| V _H | Input Hysteresis | V _{CC} = 3.3V | | — | 100 | — | mV |
| I _{CC1} I _{CC2} I _{CC3} | Quiescent Power Supply Current | V _{CC} = 3.6V | V _{IN} = GND or V _{CC} | — | — | 10 | μA |
| | | | 3.6 ≤ V _{IN} ≤ 5.5V ⁽²⁾ | — | — | 10 | |
| ΔI _{CC} | Quiescent Power Supply Current Variation | One input at V _{CC} - 0.6V, other inputs at V _{CC} or GND | | — | — | 500 | μA |

NOTES:

1. Typical values are at V_{CC} = 3.3V, +25°C ambient.
2. This applies in the disabled state only.

OUTPUT DRIVE CHARACTERISTICS

| Symbol | Parameter | Test Conditions ⁽¹⁾ | | Min. | Max. | Unit |
|-----------------|---------------------|--------------------------------|--------------------------|----------------------|------|------|
| V _{OH} | Output HIGH Voltage | V _{CC} = 2.3V to 3.6V | I _{OH} = -0.1mA | V _{CC} -0.2 | — | V |
| | | V _{CC} = 2.3V | I _{OH} = -6mA | 2 | — | |
| | | V _{CC} = 2.3V | I _{OH} = -12mA | 1.7 | — | |
| | | V _{CC} = 2.7V | | 2.2 | — | |
| | | V _{CC} = 3V | | 2.4 | — | |
| | | V _{CC} = 3V | I _{OH} = -24mA | 2.2 | — | |
| V _{OL} | Output LOW Voltage | V _{CC} = 2.3V to 3.6V | I _{OL} = 0.1mA | — | 0.2 | V |
| | | V _{CC} = 2.3V | I _{OL} = 6mA | — | 0.4 | |
| | | | I _{OL} = 12mA | — | 0.7 | |
| | | V _{CC} = 2.7V | I _{OL} = 12mA | — | 0.4 | |
| | | V _{CC} = 3V | I _{OL} = 24mA | — | 0.55 | |

NOTE:

1. V_{IH} and V_{IL} must be within the min. or max. range shown in the DC ELECTRICAL CHARACTERISTICS OVER OPERATING RANGE table for the appropriate V_{CC} range. T_A = -40°C to +85°C.

OPERATING CHARACTERISTICS, $V_{CC} = 3.3V \pm 0.3V$, $T_A = 25^\circ C$

| Symbol | Parameter | Test Conditions | Typical | Unit |
|--------|--|---------------------------|---------|------|
| CPD | Power Dissipation Capacitance per Transceiver Outputs enabled | $C_L = 0pF$, $f = 10MHz$ | 38 | pF |
| CPD | Power Dissipation Capacitance per Transceiver Outputs disabled | | 4 | |

SWITCHING CHARACTERISTICS⁽¹⁾

| Symbol | Parameter | $V_{CC} = 2.7V$ | | $V_{CC} = 3.3V \pm 0.3V$ | | Unit |
|-------------|------------------------------------|-----------------|------|--------------------------|------|------|
| | | Min. | Max. | Min. | Max. | |
| t_{PLH} | Propagation Delay | — | 4.7 | 1 | 4 | ns |
| t_{PHL} | xAx to xBx , xBx to xAx | | | | | |
| t_{PZH} | Output Enable Time | — | 6.7 | 1.5 | 5.5 | ns |
| t_{PZL} | \overline{xOE} to xAx or xBx | | | | | |
| t_{PHZ} | Output Disable Time | — | 7.1 | 1.5 | 6.6 | ns |
| t_{PLZ} | \overline{xOE} to xAx or xBx | | | | | |
| $t_{SK(0)}$ | Output Skew ⁽²⁾ | — | — | — | 1 | ns |

NOTES:

1. See TEST CIRCUITS AND WAVEFORMS. $T_A = -40^\circ C$ to $+85^\circ C$.
2. Skew between any two outputs of the same package and switching in the same direction.

TEST CIRCUITS AND WAVEFORMS

TEST CONDITIONS

| Symbol | V _{CC} ⁽¹⁾ =3.3V±0.3V | V _{CC} ⁽¹⁾ =2.7V | V _{CC} ⁽²⁾ =2.5V±0.2V | Unit |
|-------------------|---|--------------------------------------|---|------|
| V _{LOAD} | 6 | 6 | 2 x V _{CC} | V |
| V _{IH} | 2.7 | 2.7 | V _{CC} | V |
| V _T | 1.5 | 1.5 | V _{CC} / 2 | V |
| V _{LZ} | 300 | 300 | 150 | mV |
| V _{HZ} | 300 | 300 | 150 | mV |
| C _L | 50 | 50 | 30 | pF |

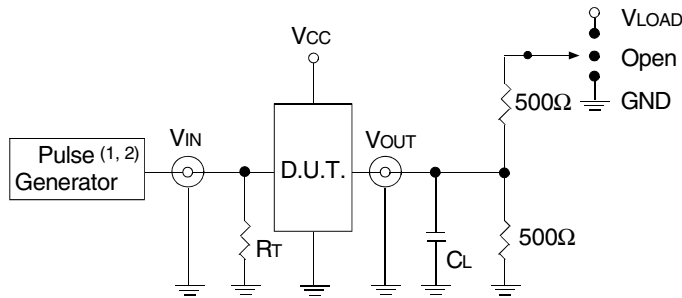

Test Circuit for All Outputs

DEFINITIONS:

C_L = Load capacitance: includes jig and probe capacitance.
R_T = Termination resistance: should be equal to Z_{OUT} of the Pulse Generator.

NOTES:

1. Pulse Generator for All Pulses: Rate ≤ 10MHz; t_F ≤ 2.5ns; t_R ≤ 2.5ns.
2. Pulse Generator for All Pulses: Rate ≤ 10MHz; t_F ≤ 2ns; t_R ≤ 2ns.

SWITCH POSITION

| Test | Switch |
|---|-------------------|
| Open Drain Disable Low Enable Low | V _{LOAD} |
| Disable High Enable High | GND |
| All Other Tests | Open |

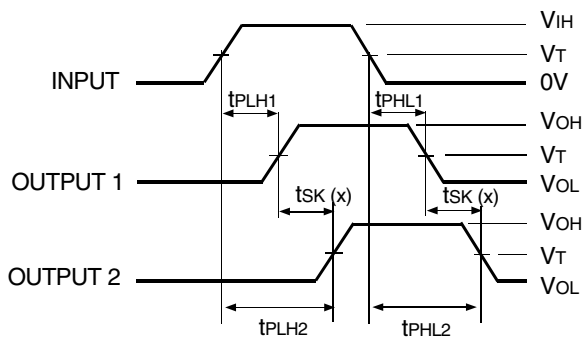

$$tsk(x) = |t_{PLH2} - t_{PLH1}| \text{ or } |t_{PHL2} - t_{PHL1}|$$

Output Skew - tsk(x)

NOTES:

1. For tsk(o) OUTPUT1 and OUTPUT2 are any two outputs.
2. For tsk(b) OUTPUT1 and OUTPUT2 are in the same bank.

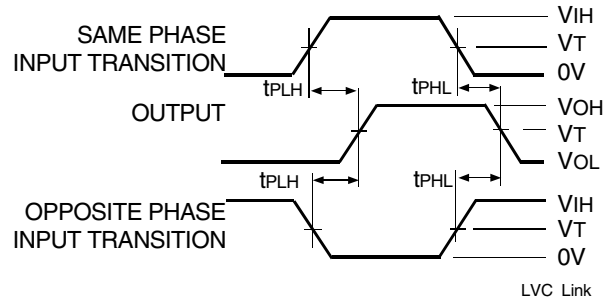

Propagation Delay

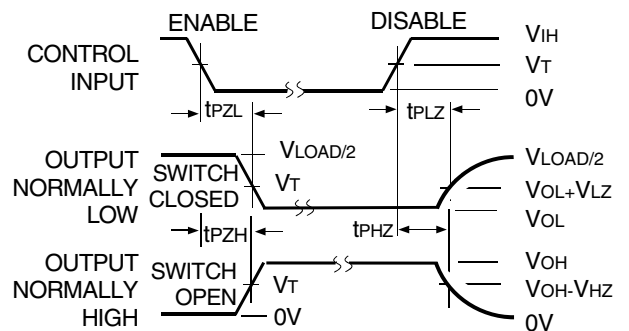

Enable and Disable Times

NOTE:

1. Diagram shown for input Control Enable-LOW and input Control Disable-HIGH.

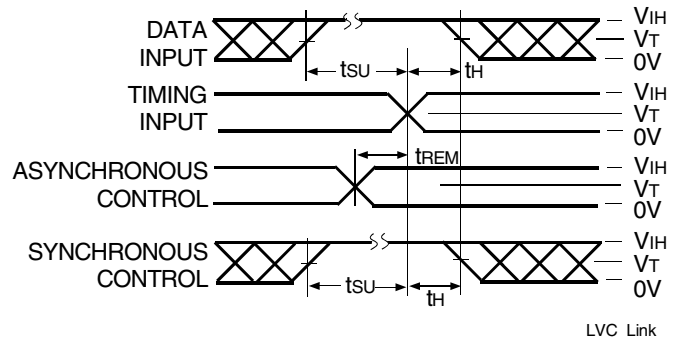

Set-up, Hold, and Release Times

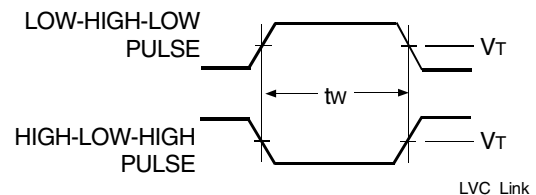

Pulse Width

ORDERING INFORMATION

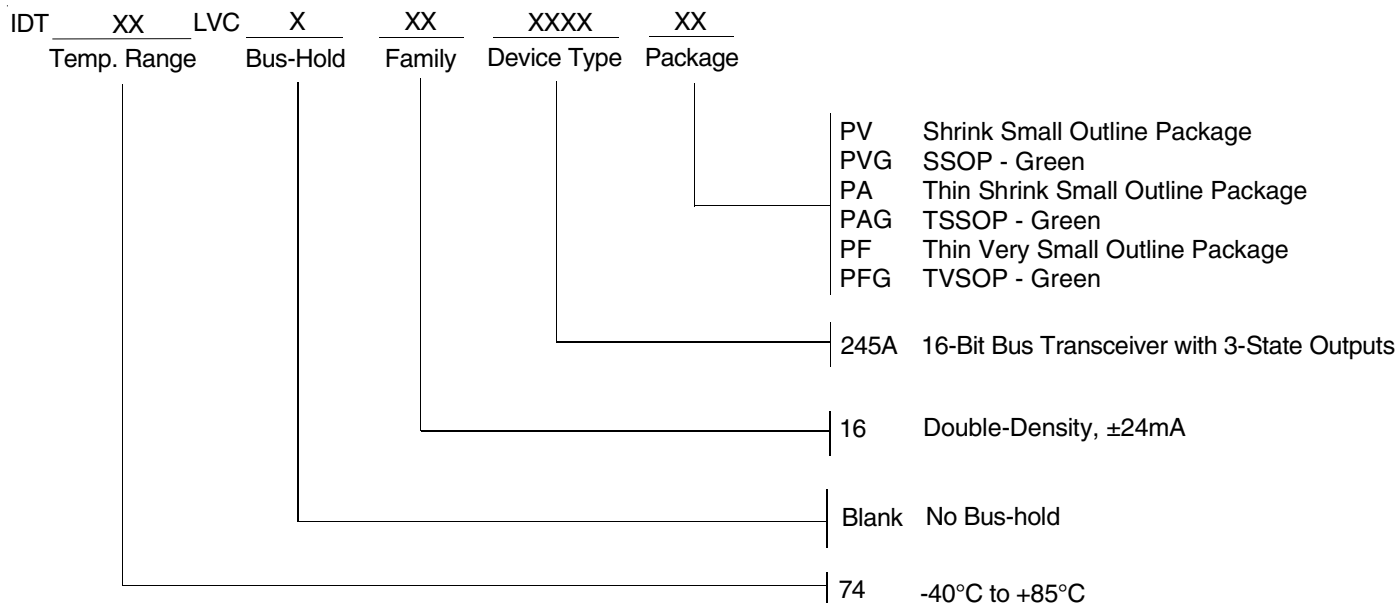

CORPORATE HEADQUARTERS
 6024 Silver Creek Valley Road
 San Jose, CA 95138

for SALES:
 800-345-7015 or 408-284-8200
 fax: 408-284-2775
 www.idt.com

for Tech Support:
 logichelp@idt.com