



## FAST CMOS OCTAL D FLIP-FLOP WITH CLOCK ENABLE

**IDT74FCT377AT/CT/DT**

### FEATURES:

- A, C, and D grades
- Low input and output leakage  $\leq 1\mu\text{A}$  (max.)
- CMOS power levels
- True TTL input and output compatibility:
  - $V_{OH} = 3.3V$  (typ.)
  - $V_{OL} = 0.3V$  (typ.)
- High Drive outputs (-15mA IOH, 48mA IOL)
- Meets or exceeds JEDEC standard 18 specifications
- Power off disable outputs permit "live insertion"
- Available in SOIC and QSOP packages

### DESCRIPTION:

The IDT74FCT377T is an octal D flip-flop built using an advanced dual metal CMOS technology. The IDT74FCT377T has eight edge-triggered, D-type flip-flops with individual D inputs and O outputs. The common buffered Clock (CP) input loads all flip-flops simultaneously when the Clock Enable ( $\overline{CE}$ ) is low. The register is fully edge-triggered. The state of each D input, one set-up time before the low-to-high clock transition, is transferred to the corresponding flip-flop's O output. The  $\overline{CE}$  input must be stable only one set-up time prior to the low-to-high transition for predictable operation.

### FUNCTIONAL BLOCK DIAGRAM

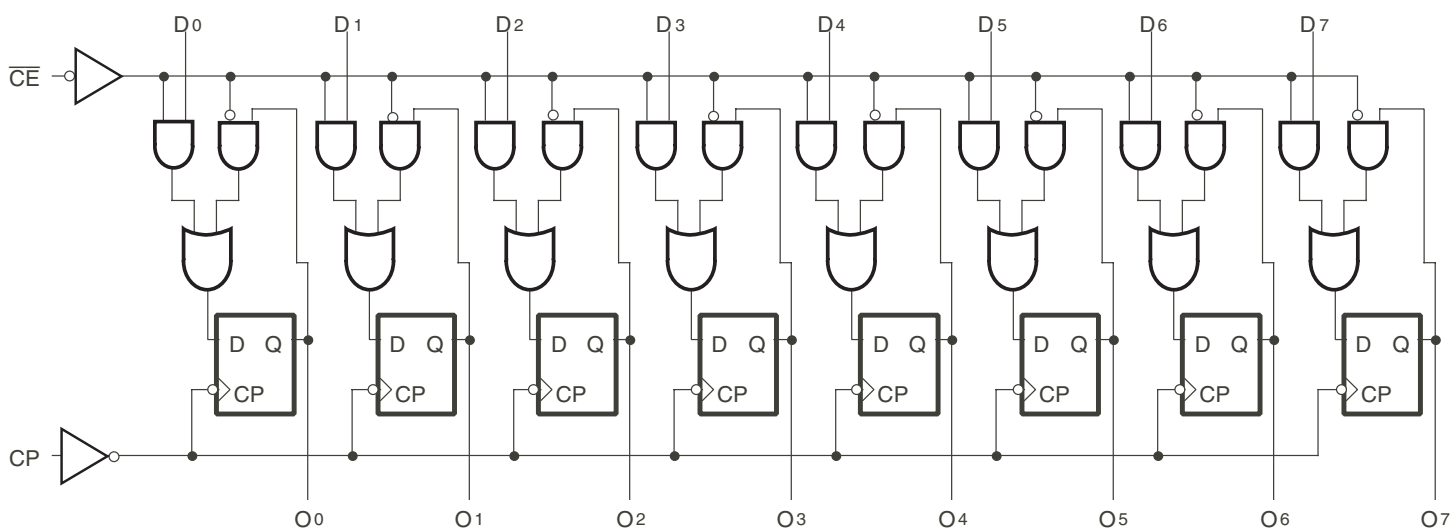

## PIN CONFIGURATION

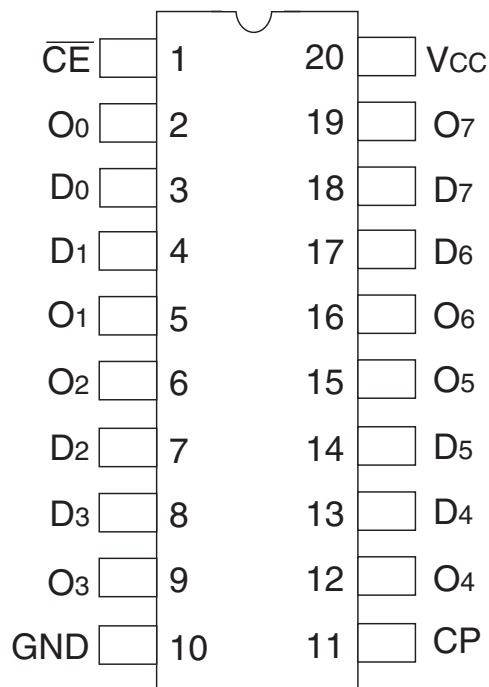

SOIC/ QSOP  
TOP VIEW

## ABSOLUTE MAXIMUM RATINGS<sup>(1)</sup>

Symbol	Description	Max	Unit
V <sub>TERM</sub> <sup>(2)</sup>	Terminal Voltage with Respect to GND	-0.5 to +7	V
V <sub>TERM</sub> <sup>(3)</sup>	Terminal Voltage with Respect to GND	-0.5 to V <sub>CC</sub> +0.5	V
T <sub>STG</sub>	Storage Temperature	-65 to +150	°C
I <sub>OUT</sub>	DC Output Current	-60 to +120	mA

### NOTES:

- Stresses greater than those listed under ABSOLUTE MAXIMUM RATINGS may cause permanent damage to the device. This is a stress rating only and functional operation of the device at these or any other conditions above those indicated in the operational sections of this specification is not implied. Exposure to absolute maximum rating conditions for extended periods may affect reliability. No terminal voltage may exceed V<sub>CC</sub> by +0.5V unless otherwise noted.
- Inputs and V<sub>CC</sub> terminals only.
- Output and I/O terminals only.

## CAPACITANCE (T<sub>A</sub> = +25°C, F = 1.0MHz)

Symbol	Parameter <sup>(1)</sup>	Conditions	Typ.	Max.	Unit
C <sub>IN</sub>	Input Capacitance	V <sub>IN</sub> = 0V	6	10	pF
C <sub>OUT</sub>	Output Capacitance	V <sub>OUT</sub> = 0V	8	12	pF

### NOTE:

- This parameter is measured at characterization but not tested.

## PIN DESCRIPTION

Pin Names	Description
D <sub>0</sub> – D <sub>7</sub>	Data Inputs
$\overline{CE}$	Clock Enable (Active LOW)
O <sub>0</sub> – O <sub>7</sub>	Data Outputs
CP	Clock Pulse Input

## FUNCTION TABLE<sup>(1)</sup>

Operating Mode	Inputs			Outputs
	CP	$\overline{CE}$	D	O
Load "1"	↑	l	h	H
Load "0"	↑	l	l	L
Hold	↑	h	X	No Change
	H	H	X	No Change

### NOTE:

- H = HIGH Voltage Level  
h = HIGH Voltage Level one setup time prior to the LOW-to-HIGH Clock Transition  
L = LOW Voltage Level  
l = LOW Voltage Level one setup time prior to the LOW-to-HIGH Clock Transition  
X = Don't Care  
↑ = LOW-to-HIGH Clock Transition

## DC ELECTRICAL CHARACTERISTICS OVER OPERATING RANGE

Following Conditions Apply Unless Otherwise Specified:

Industrial :  $T_A = -40^{\circ}\text{C}$  to  $+85^{\circ}\text{C}$ ,  $V_{CC} = 5.0\text{V} \pm 5\%$

Symbol	Parameter	Test Conditions <sup>(1)</sup>		Min.	Typ. <sup>(2)</sup>	Max.	Unit
$V_{IH}$	Input HIGH Level	Guaranteed Logic HIGH Level		2	—	—	V
$V_{IL}$	Input LOW Level	Guaranteed Logic LOW Level		—	—	0.8	V
$I_{IH}$	Input HIGH Current <sup>(4)</sup>	$V_{CC} = \text{Max.}$	$V_I = 2.7\text{V}$	—	—	$\pm 1$	$\mu\text{A}$
$I_{IL}$	Input LOW Current <sup>(4)</sup>	$V_{CC} = \text{Max.}$	$V_I = 0.5\text{V}$	—	—	$\pm 1$	$\mu\text{A}$
$I_I$	Input HIGH Current <sup>(4)</sup>	$V_{CC} = \text{Max.}, V_I = V_{CC} (\text{Max.})$		—	—	$\pm 1$	$\mu\text{A}$
$V_{IK}$	Clamp Diode Voltage	$V_{CC} = \text{Min.}, I_N = -18\text{mA}$		—	-0.7	-1.2	V
$I_{OS}$	Short Circuit Current	$V_{CC} = \text{Max.}^{(3)}, V_O = \text{GND}$		-60	-120	-225	mA
$V_{OH}$	Output HIGH Voltage	$V_{CC} = \text{Min.}$ $V_{IN} = V_{IH}$ or $V_{IL}$	$I_{OH} = -8\text{mA}$	2.4	3.3	—	V
			$I_{OH} = -12\text{mA}$	2	3	—	
$V_{OL}$	Output LOW Voltage	$V_{CC} = \text{Min.}$ $V_{IN} = V_{IH}$ or $V_{IL}$	$I_{OL} = 48\text{mA}$	—	0.3	0.5	V
$I_{OFF}$	Input/Output Power Off Leakage <sup>(5)</sup>	$V_{CC} = 0\text{V}, V_{IN}$ or $V_O = 4.5\text{V}$		—	—	$\pm 1$	$\mu\text{A}$
$V_H$	Input Hysteresis	—		—	200	—	mV
$I_{CC}$	Quiescent Power	$V_{CC} = \text{Max.}$		—	0.01	1	mA
	Supply Current	$V_{IN} = \text{GND}$ or $V_{CC}$					

### NOTES:

1. For conditions shown as Max. or Min., use appropriate value specified under Electrical Characteristics for the applicable device type.
2. Typical values are at  $V_{CC} = 5.0\text{V}$ ,  $+25^{\circ}\text{C}$  ambient.
3. Not more than one output should be shorted at one time. Duration of the short circuit test should not exceed one second.
4. The test limit for this parameter is  $\pm 5\mu\text{A}$  at  $T_A = -55^{\circ}\text{C}$ .
5. This parameter is guaranteed but not tested.

## POWER SUPPLY CHARACTERISTICS

Symbol	Parameter	Test Conditions <sup>(1)</sup>		Min.	Typ. <sup>(2)</sup>	Max.	Unit
$\Delta I_{CC}$	Quiescent Power Supply Current TTL Inputs HIGH	V <sub>CC</sub> = Max. V <sub>IN</sub> = 3.4V <sup>(3)</sup>		—	0.5	2	mA
I <sub>CCD</sub>	Dynamic Power Supply Current <sup>(4)</sup>	V <sub>CC</sub> = Max., Outputs Open $\overline{CE}$ = GND One Input Toggling 50% Duty Cycle	V <sub>IN</sub> = V <sub>CC</sub> V <sub>IN</sub> = GND	—	0.15	0.25	mA/ MHz
I <sub>C</sub>	Total Power Supply Current <sup>(6)</sup>	V <sub>CC</sub> = Max., Outputs Open f <sub>CP</sub> = 10MHz $\overline{CE}$ = GND One Bit Toggling f <sub>i</sub> = 5MHz 50% Duty Cycle	V <sub>IN</sub> = V <sub>CC</sub> V <sub>IN</sub> = GND	—	1.5	3.5	mA
			V <sub>IN</sub> = 3.4V V <sub>IN</sub> = GND	—	2	5.5	
		V <sub>CC</sub> = Max., Outputs Open f <sub>CP</sub> = 10MHz, 50% Duty Cycle $\overline{CE}$ = GND Eight Bits Toggling f <sub>i</sub> = 2.5MHz 50% Duty Cycle	V <sub>IN</sub> = V <sub>CC</sub> V <sub>IN</sub> = GND	—	3.8	7.3 <sup>(5)</sup>	
			V <sub>IN</sub> = 3.4V V <sub>IN</sub> = GND	—	6	16.3 <sup>(5)</sup>	

### NOTES:

- For conditions shown as Min. or Max., use appropriate value specified under Electrical Characteristics for the applicable device type.
- Typical values are at V<sub>CC</sub> = 5.0V, +25°C ambient.
- Per TTL driven input; (V<sub>IN</sub> = 3.4V). All other inputs at V<sub>CC</sub> or GND.
- This parameter is not directly testable, but is derived for use in Total Power Supply Calculations.
- Values for these conditions are examples of  $\Delta I_{CC}$  formula. These limits are guaranteed but not tested.
- I<sub>C</sub> = I<sub>QUIESCENT</sub> + I<sub>INPUTS</sub> + I<sub>DYNAMIC</sub>  
 $I_C = I_{CC} + \Delta I_{CC} D_H N_T + I_{CCD} (f_{CP}/2 + f_i N_i)$   
 I<sub>CC</sub> = Quiescent Current  
 $\Delta I_{CC}$  = Power Supply Current for a TTL High Input (V<sub>IN</sub> = 3.4V)  
 D<sub>H</sub> = Duty Cycle for TTL Inputs High  
 N<sub>T</sub> = Number of TTL Inputs at D<sub>H</sub>  
 I<sub>CCD</sub> = Dynamic Current caused by an Input Transition Pair (HLH or LHL)  
 f<sub>CP</sub> = Clock Frequency for Register Devices (Zero for Non-Register Devices)  
 f<sub>i</sub> = Output Frequency  
 N<sub>i</sub> = Number of Outputs at f<sub>i</sub>  
 All currents are in milliamps and all frequencies are in megahertz.

## SWITCHING CHARACTERISTICS OVER OPERATING RANGE

Symbol	Parameter	Condition <sup>(1)</sup>	74FCT377AT		74FCT377CT		74FCT377DT		Unit
			Min. <sup>(2)</sup>	Max.	Min. <sup>(2)</sup>	Max.	Min. <sup>(2)</sup>	Max.	
t <sub>PLH</sub>	Propagation Delay	C <sub>L</sub> = 50pF R <sub>L</sub> = 500Ω	2	7.2	2	5.2	2	4.4	ns
t <sub>PHL</sub>	CP to Qx		2	—	2	—	2	—	ns
t <sub>SU</sub>	Set-up Time HIGH or LOW Dx to CP		1.5	—	1.5	—	1	—	ns
t <sub>H</sub>	Hold Time HIGH or LOW Dx to CP		3.5	—	3.5	—	3	—	ns
t <sub>SU</sub>	Set-up Time HIGH or LOW $\overline{CE}$ to CP		1.5	—	1.5	—	0	—	ns
t <sub>H</sub>	Hold Time HIGH or LOW $\overline{CE}$ to CP		8	—	6	—	3	—	ns
t <sub>w</sub>	CP Pulse Width HIGH or LOW								

### NOTES:

- See test circuit and waveforms.
- Minimum limits are guaranteed but not tested on Propagation Delays.

## TEST CIRCUITS AND WAVEFORMS

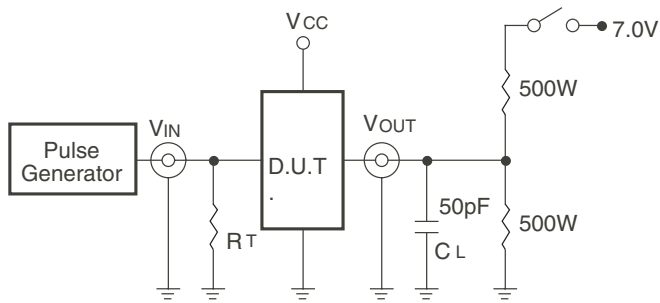

Octal Link

**Test Circuits for All Outputs**

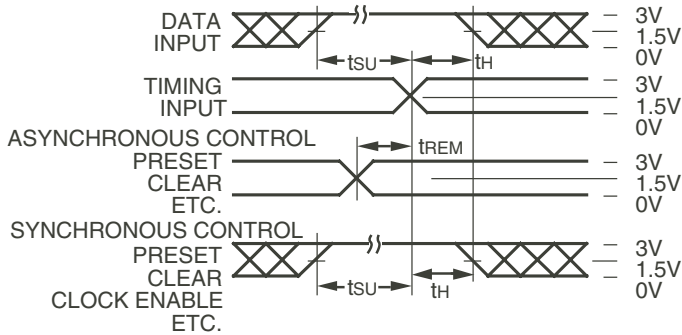

Octal Link

**Set-Up, Hold, and Release Times**

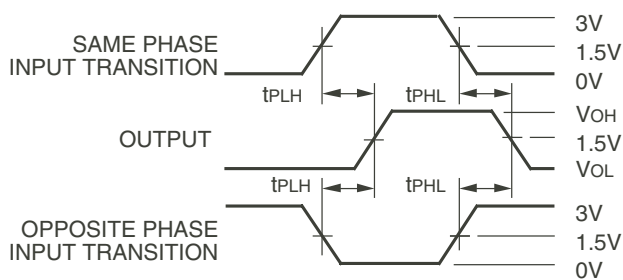

Octal Link

**Propagation Delay**

## SWITCH POSITION

Test	Switch
Open Drain Disable Low Enable Low	Closed
All Other Tests	Open

### DEFINITIONS:

$C_L$  = Load capacitance: includes jig and probe capacitance.

$R_T$  = Termination resistance: should be equal to  $Z_{OUT}$  of the Pulse Generator.

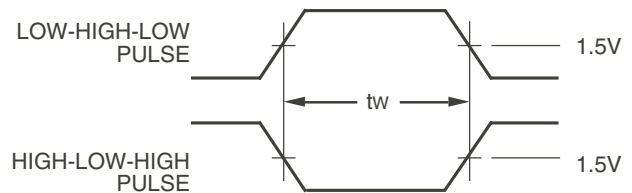

**Pulse Width**

Octal Link

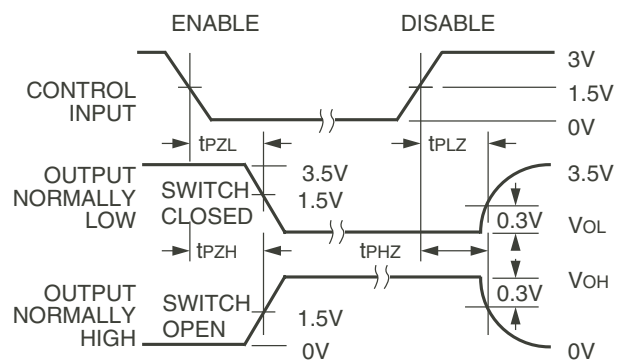

Octal Link

**Enable and Disable Times**

### NOTES:

- Diagram shown for input Control Enable-LOW and input Control Disable-HIGH.
- Pulse Generator for All Pulses: Rate  $\leq 1.0\text{MHz}$ ;  $t_r \leq 2.5\text{ns}$ ;  $t_f \leq 2.5\text{ns}$ .

## ORDERING INFORMATION

XX	FCT	XXXX	XX	X		
Temp. Range		Device Type	Package	Process		
					Blank	Industrial
					SOG	Small Outline IC - Green
					QG	Quarter-size Small Outline Package - Green
					377AT 377CT 377DT	Fast CMOS Octal D Flip-Flop with Clock Enable
					74	40 C to +85 C

## Datasheet Document History

10/03/09 Pg. 6 Updated the ordering information by removing the "IDT" notation and non RoHS part.



**CORPORATE HEADQUARTERS**  
 6024 Silver Creek Valley Road  
 San Jose, CA 95138

**for SALES:**  
 800-345-7015 or 408-284-8200  
 fax: 408-284-2775  
 www.idt.com

**for Tech Support:**  
 logichelp@idt.com