



## 3.3V CMOS OCTAL BIDIRECTIONAL TRANSCEIVER

**IDT74FCT3245/A**

### FEATURES:

- 0.5 MICRON CMOS Technology
- ESD > 2000V per MIL-STD-883, Method 3015; > 200V using machine model (C = 200pF, R = 0)
- $V_{CC} = 3.3V \pm 0.3V$ , Normal Range
- $V_{CC} = 2.7V$  to  $3.6V$ , Extended Range
- CMOS power levels ( $0.4\mu W$  typ. static)
- Rail-to-Rail output swing for increased noise margin
- Available in QSOP and TSSOP packages

### DESCRIPTION:

The FCT3245/A octal transceivers are built using advanced dual metal CMOS technology. These high-speed, low-power transceivers are ideal for asynchronous communication between two buses (A and B). The direction control pin (DIR) controls the direction of data flow. The output enable pin ( $\overline{OE}$ ) overrides the direction control and disables both ports. All inputs are designed with hysteresis for improved noise margin.

The FCT3245/A has series current limiting resistors. These offer low ground bounce, minimal undershoot, and controlled output fall times—reducing the need for external series terminating resistors.

### FUNCTIONAL BLOCK DIAGRAM

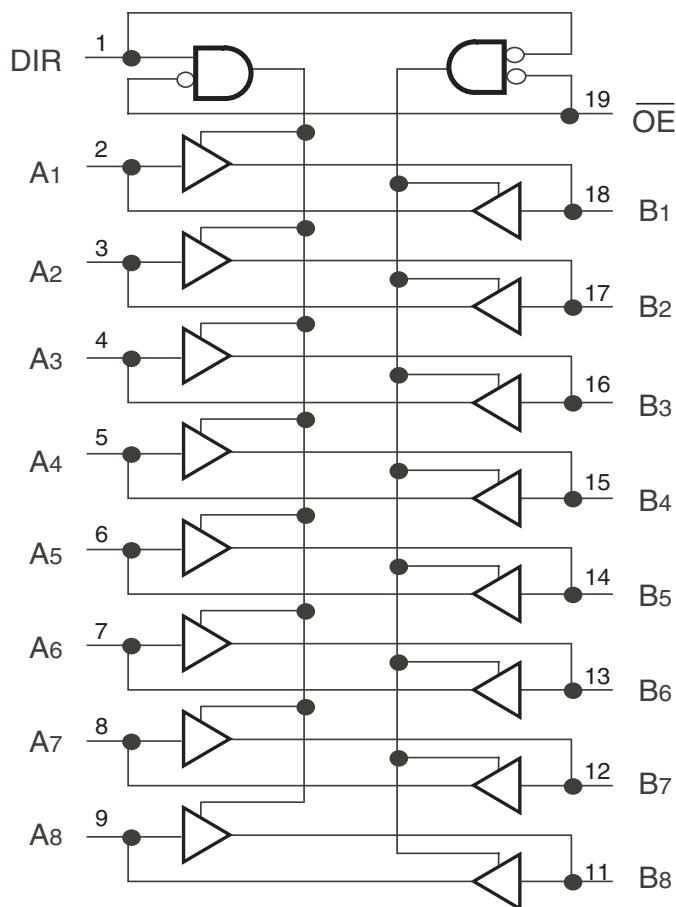

The IDT logo is a registered trademark of Integrated Device Technology, Inc.

**INDUSTRIAL TEMPERATURE RANGE**

**OCTOBER 2009**

## PIN CONFIGURATION

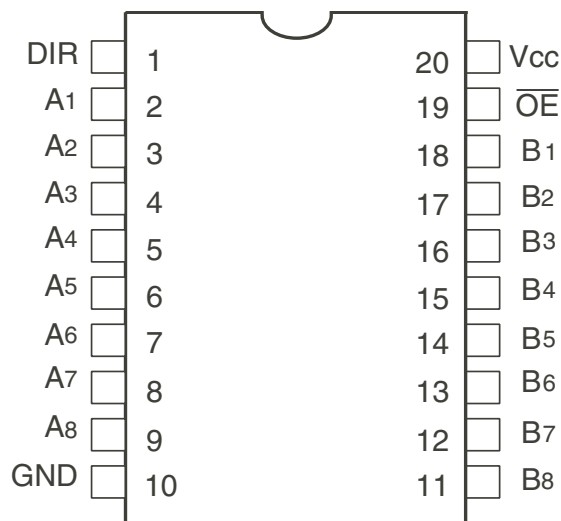

QSOP/TSSOP  
TOP VIEW

## ABSOLUTE MAXIMUM RATINGS<sup>(1)</sup>

Symbol	Description	Max	Unit
V <sub>TERM</sub> <sup>(2)</sup>	Terminal Voltage with Respect to GND	-0.5 to +4.6	V
V <sub>TERM</sub> <sup>(3)</sup>	Terminal Voltage with Respect to GND	-0.5 to +7	V
V <sub>TERM</sub> <sup>(4)</sup>	Terminal Voltage with Respect to GND	-0.5 to V <sub>CC</sub> +0.5	V
T <sub>STG</sub>	Storage Temperature	-65 to +150	°C
I <sub>OUT</sub>	DC Output Current	-60 to +60	mA

### NOTES:

- Stresses greater than those listed under ABSOLUTE MAXIMUM RATINGS may cause permanent damage to the device. This is a stress rating only and functional operation of the device at these or any other conditions above those indicated in the operational sections of this specification is not implied. Exposure to absolute maximum rating conditions for extended periods may affect reliability.
- V<sub>CC</sub> terminals.
- Input terminals.
- Outputs and I/O terminals.

## CAPACITANCE (T<sub>A</sub> = +25°C, F = 1.0MHz)

Symbol	Parameter <sup>(1)</sup>	Conditions	Typ.	Max.	Unit
C <sub>IN</sub>	Input Capacitance	V <sub>IN</sub> = 0V	3.5	6	pF
C <sub>OUT</sub>	Output Capacitance	V <sub>OUT</sub> = 0V	4	8	pF

### NOTE:

- This parameter is measured at characterization but not tested.

## PIN DESCRIPTION

Pin Names	Description
$\overline{OE}$	3-State Output Enable Inputs (Active LOW)
DIR	Direction Control Output
A <sub>x</sub>	Side A Inputs or 3-State Outputs
B <sub>x</sub>	Side B Inputs or 3-State Outputs

## FUNCTION TABLE<sup>(1)</sup>

Inputs		Outputs
$\overline{OE}$	DIR	
L	L	Bus B Data to Bus A
L	H	Bus A Data to Bus B
H	X	High Z State

### NOTE:

- H = HIGH Voltage Level  
X = Don't Care  
L = LOW Voltage Level  
Z = High Impedance

## DC ELECTRICAL CHARACTERISTICS OVER OPERATING RANGE

Following Conditions Apply Unless Otherwise Specified:

Industrial:  $T_A = -40^{\circ}\text{C}$  to  $+85^{\circ}\text{C}$ ,  $V_{CC} = 2.7\text{V}$  to  $3.6\text{V}$

Symbol	Parameter	Test Conditions <sup>(1)</sup>		Min.	Typ. <sup>(2)</sup>	Max.	Unit
V <sub>IH</sub>	Input HIGH Level (Input pins)	Guaranteed Logic HIGH Level		2	—	5.5	V
	Input HIGH Level (I/O pins)			2	—	V <sub>CC</sub> +0.5	
V <sub>IL</sub>	Input LOW Level (Input and I/O pins)	Guaranteed Logic LOW Level		-0.5	—	0.8	V
I <sub>IH</sub>	Input HIGH Current (Input pins)	V <sub>CC</sub> = Max.	V <sub>I</sub> = 5.5V	—	—	±1	μA
	Input HIGH Current (I/O pins)		V <sub>I</sub> = V <sub>CC</sub>	—	—	±1	
I <sub>IL</sub>	Input LOW Current (Input pins)		V <sub>I</sub> = GND	—	—	±1	
	Input LOW Current (I/O pins)		V <sub>I</sub> = GND	—	—	±1	
I <sub>OZH</sub>	High Impedance Output Current (3-State Output pins)	V <sub>CC</sub> = Max.	V <sub>O</sub> = V <sub>CC</sub>	—	—	±1	μA
			V <sub>O</sub> = GND	—	—	±1	
V <sub>IK</sub>	Clamp Diode Voltage	V <sub>CC</sub> = Min., I <sub>IN</sub> = -18mA		—	-0.7	-1.2	V
I <sub>ODH</sub>	Output HIGH Current	V <sub>CC</sub> = 3.3V, V <sub>IN</sub> = V <sub>IH</sub> or V <sub>IL</sub> , V <sub>O</sub> = 1.5V <sup>(3)</sup>		-36	-60	-110	mA
I <sub>ODL</sub>	Output LOW Current	V <sub>CC</sub> = 3.3V, V <sub>IN</sub> = V <sub>IH</sub> or V <sub>IL</sub> , V <sub>O</sub> = 1.5V <sup>(3)</sup>		50	90	200	mA
V <sub>OH</sub>	Output HIGH Voltage	V <sub>CC</sub> = Min.	I <sub>OH</sub> = -0.1mA	V <sub>CC</sub> -0.2	—	—	V
		V <sub>IN</sub> = V <sub>IH</sub> or V <sub>IL</sub>	I <sub>OH</sub> = -3mA	2.4	3	—	
		V <sub>CC</sub> = 3V V <sub>IN</sub> = V <sub>IH</sub> or V <sub>IL</sub>	I <sub>OH</sub> = -8mA	2.4 <sup>(5)</sup>	3	—	
V <sub>OL</sub>	Output LOW Voltage	V <sub>CC</sub> = Min.	I <sub>OL</sub> = 0.1mA	—	—	0.2	V
		V <sub>IN</sub> = V <sub>IH</sub> or V <sub>IL</sub>	I <sub>OL</sub> = 16mA	—	0.2	0.4	
			I <sub>OL</sub> = 24mA	—	0.3	0.55	
		V <sub>CC</sub> = 3V V <sub>IN</sub> = V <sub>IH</sub> or V <sub>IL</sub>	I <sub>OL</sub> = 24mA		0.3	0.5	
I <sub>OS</sub>	Short Circuit Current <sup>(4)</sup>	V <sub>CC</sub> = Max., V <sub>O</sub> = GND <sup>(3)</sup>		-60	-135	-240	mA
V <sub>H</sub>	Input Hysteresis	—		—	150	—	mV
I <sub>CCL</sub> I <sub>CCH</sub> I <sub>CCZ</sub>	Quiescent Power Supply Current	V <sub>CC</sub> = Max., V <sub>IN</sub> = GND or V <sub>CC</sub>		—	0.1	10	μA

### NOTES:

1. For conditions shown as Min. or Max., use appropriate value specified under Electrical Characteristics for the applicable device type.
2. Typical values are at V<sub>CC</sub> = 3.3V, +25°C ambient and maximum loading.
3. Not more than one output should be tested at one time. Duration of the test should not exceed one second.
4. This parameter is guaranteed but not tested.
5. V<sub>OH</sub> = V<sub>CC</sub> - 0.6V at rated current.

## POWER SUPPLY CHARACTERISTICS

Symbol	Parameter	Test Conditions <sup>(1)</sup>		Min.	Typ. <sup>(2)</sup>	Max.	Unit
I <sub>CC</sub>	Quiescent Power Supply Current	V <sub>CC</sub> = Max.	V <sub>IN</sub> = V <sub>CC</sub> - 0.6V	—	2	30	μA
I <sub>CCD</sub>	Dynamic Power Supply Current <sup>(4)</sup>	V <sub>CC</sub> = Max. Outputs Open $\overline{OE}$ = DIR = GND One Input Toggling 50% Duty Cycle	V <sub>IN</sub> = V <sub>CC</sub> V <sub>IN</sub> = GND	—	60	85	μA/ MHz
I <sub>C</sub>	Total Power Supply Current <sup>(6)</sup>	V <sub>CC</sub> = Max. Outputs Open f <sub>i</sub> = 10MHz 50% Duty Cycle $\overline{OE}$ = DIR = GND One Bit Toggling	V <sub>IN</sub> = V <sub>CC</sub> V <sub>IN</sub> = GND	—	0.6	0.9	mA
			V <sub>IN</sub> = V <sub>CC</sub> - 0.6V V <sub>IN</sub> = GND	—	0.6	0.9	
		V <sub>CC</sub> = Max. Outputs Open f <sub>i</sub> = 2.5MHz 50% Duty Cycle $\overline{OE}$ = DIR = GND Eight Bits Toggling	V <sub>IN</sub> = V <sub>CC</sub> V <sub>IN</sub> = GND	—	1.2	1.7 <sup>(5)</sup>	
			V <sub>IN</sub> = V <sub>CC</sub> - 0.6V V <sub>IN</sub> = GND	—	1.2	1.8 <sup>(5)</sup>	

### NOTES:

- For conditions shown as Min. or Max., use appropriate value specified under Electrical Characteristics for the applicable device type.
- Typical values are at V<sub>CC</sub> = 3.3V, +25°C ambient.
- Per TTL driven input. All other inputs at V<sub>CC</sub> or GND.
- This parameter is not directly testable, but is derived for use in Total Power Supply Calculations.
- Values for these conditions are examples of ΔI<sub>CC</sub> formula. These limits are guaranteed but not tested.
- I<sub>C</sub> = I<sub>QUIESCENT</sub> + I<sub>INPUTS</sub> + I<sub>DYNAMIC</sub>  
 $I_C = I_{CC} + \Delta I_{CC} D_H N_T + I_{CCD} (f_{CP} N_{CP} / 2 + f_i N_i)$   
 I<sub>CC</sub> = Quiescent Current (I<sub>CC</sub>, I<sub>CCH</sub>, and I<sub>CCZ</sub>)  
 ΔI<sub>CC</sub> = Power Supply Current for a TTL High Input  
 D<sub>H</sub> = Duty Cycle for TTL Inputs High  
 N<sub>T</sub> = Number of TTL Inputs at D<sub>H</sub>  
 I<sub>CCD</sub> = Dynamic Current caused by an Input Transition Pair (HLH or LHL)  
 f<sub>CP</sub> = Clock Frequency for register devices (zero for non-register devices)  
 N<sub>CP</sub> = Number of clock inputs at f<sub>CP</sub>  
 f<sub>i</sub> = Input Frequency  
 N<sub>i</sub> = Number of Inputs at f<sub>i</sub>

## SWITCHING CHARACTERISTICS OVER OPERATING RANGE<sup>(1)</sup>

Symbol	Parameter	Condition <sup>(2)</sup>	74FCT3245		74FCT3245A		Unit										
			Min. <sup>(3)</sup>	Max.	Min. <sup>(3)</sup>	Max.											
t <sub>PLH</sub>	Propagation Delay	C <sub>L</sub> = 50pF R <sub>L</sub> = 500Ω	1.5	7	1.5	4.6	ns										
t <sub>PHL</sub>	A to B, B to A																
t <sub>PZH</sub>	Output Enable Time							1.5	9.5	1.5	6.2	ns					
t <sub>PZL</sub>	$\overline{OE}$ to A or B																
t <sub>PHZ</sub>	Output Disable Time												1.5	7.5	1.5	5	ns
t <sub>PLZ</sub>	$\overline{OE}$ to A or B																
t <sub>PZH</sub>	Output Enable Time	1.5	9.5	1.5	6.2	ns											
t <sub>PZL</sub>	DIR to A or B <sup>(4)</sup>																
t <sub>PHZ</sub>	Output Disable Time						1.5	7.5	1.5	5	ns						
t <sub>PLZ</sub>	DIR to A or B <sup>(4)</sup>																

### NOTES:

- Propagation Delays and Enable/Disable times are with V<sub>CC</sub> = 3.3V ±0.3V, Normal Range. For V<sub>CC</sub> = 2.7V to 3.6V, Extended Range, all Propagation Delays and Enable/Disable times should be degraded by 20%.
- See test circuit and waveforms.
- Minimum limits are guaranteed but not tested on Propagation Delays.
- This parameter is guaranteed but not tested.

## TEST CIRCUITS AND WAVEFORMS

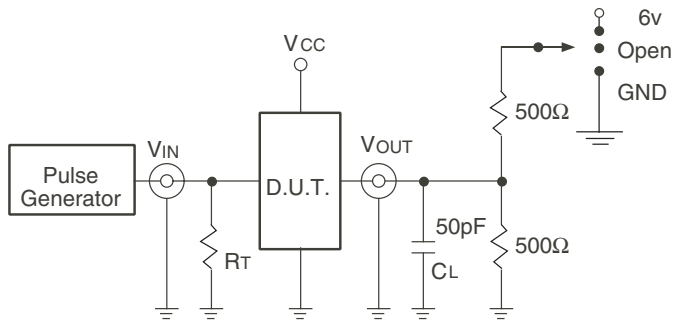

Test Circuits for All Outputs

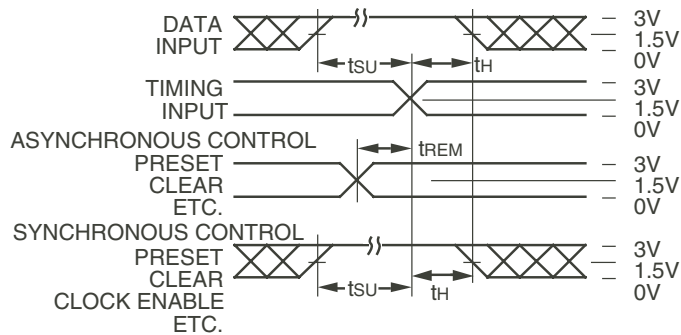

Set-Up, Hold, and Release Times

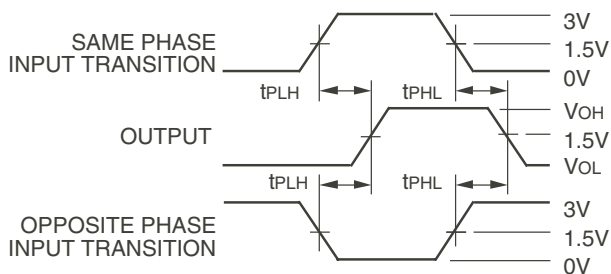

Propagation Delay

## SWITCH POSITION

Test	Switch
Open Drain Disable Low Enable Low	6V
Disable High Enable High	GND
All Other Tests	Open

### DEFINITIONS:

CL = Load capacitance: includes jig and probe capacitance.  
RT = Termination resistance: should be equal to ZOUT of the Pulse Generator.

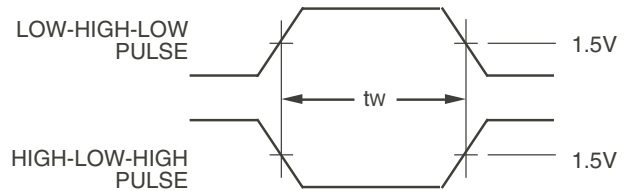

Pulse Width

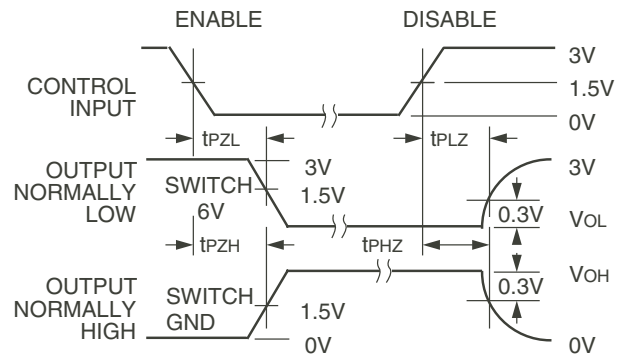

Enable and Disable Times

### NOTES:

1. Diagram shown for input Control Enable-LOW and input Control Disable-HIGH.
2. Pulse Generator for All Pulses: Rate  $\leq 1.0\text{MHz}$ ;  $Z_o \leq 50\Omega$ ;  $t_r \leq 2.5\text{ns}$ ;  $t_f \leq 2.5\text{ns}$ .
3. If Vcc is below 3V, input voltage swings should be adjusted not to exceed Vcc.

## ORDERING INFORMATION

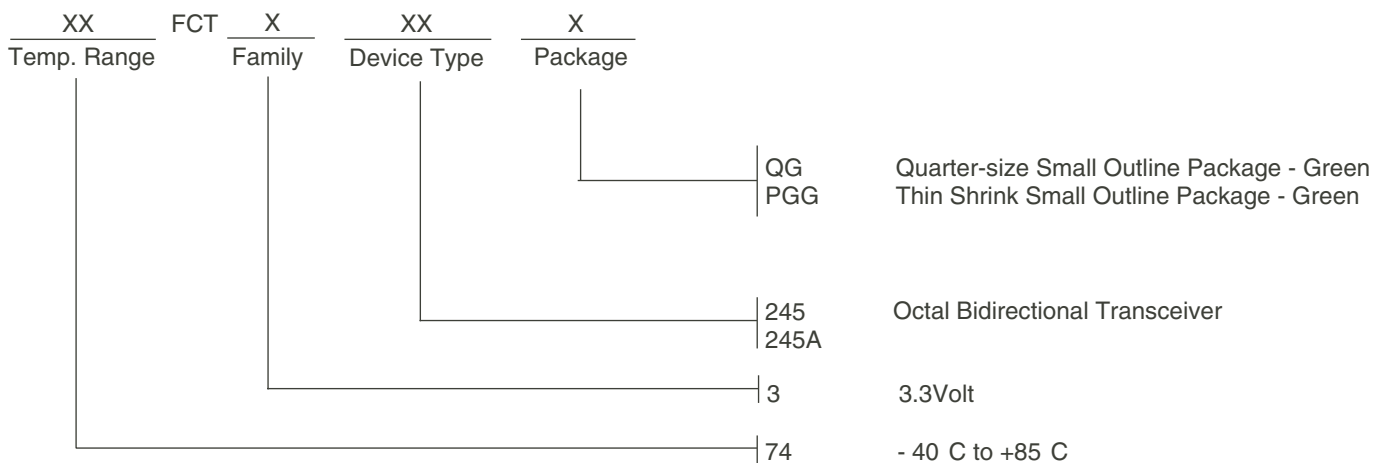

## Datasheet Document History

10/03/09 Pg. 6 Updated the ordering information by removing the "IDT" notation and non RoHS part.



**CORPORATE HEADQUARTERS**  
 6024 Silver Creek Valley Road  
 San Jose, CA 95138

**for SALES:**  
 800-345-7015 or 408-284-8200  
 fax: 408-284-2775  
 www.idt.com

**for Tech Support:**  
 logichelp@idt.com