



**128K X 36**  
**3.3V Synchronous SRAMs**  
**2.5V I/O, Pipelined Outputs,**  
**Burst Counter, Single Cycle Deselect**

**IDT71V25761YS/S**

**Features**

- ◆ 128K x 36 memory configuration
- ◆ Supports high system speed:
  - Commercial:
    - 200MHz 3.1ns clock access time
  - Commercial and Industrial:
    - 183MHz 3.3ns clock access time
    - 166MHz 3.5ns clock access time
- ◆ **LBO** input selects interleaved or linear burst mode
- ◆ Self-timed write cycle with global write control (**GW**), byte write enable (**BWE**), and byte writes (**BWx**)
- ◆ 3.3V core power supply
- ◆ Power down controlled by **ZZ** input
- ◆ 2.5V I/O
- ◆ Optional - Boundary Scan JTAG Interface (IEEE 1149.1 Compliant)
- ◆ Packaged in a JEDEC Standard 100-pin plastic thin quad flatpack (TQFP), 119 ball grid array (BGA) and 165 fine pitch ball grid array

**Description**

The IDT71V25761 are high-speed SRAMs organized as 128K x 36. The IDT71V25761 SRAMs contain write, data, address and control registers. Internal logic allows the SRAM to generate a self-timed write based upon a decision which can be left until the end of the write cycle.

The burst mode feature offers the highest level of performance to the system designer, as the IDT71V25761 can provide four cycles of data for a single address presented to the SRAM. An internal burst address counter accepts the first cycle address from the processor, initiating the access sequence. The first cycle of output data will be pipelined for one cycle before it is available on the next rising clock edge. If burst mode operation is selected (**ADV**=LOW), the subsequent three cycles of output data will be available to the user on the next three rising clock edges. The order of these three addresses are defined by the internal burst counter and the **LBO** input pin.

The IDT71V25761 SRAMs utilize IDT's latest high-performance CMOS process and are packaged in a JEDEC standard 14mm x 20mm 100-pin thin plastic quad flatpack (TQFP) as well as a 119 ball grid array (BGA) and 165 fine pitch ball grid array (fBGA).

**Pin Description Summary**

|   |                                   |        |              |
|---|-----------------------------------|--------|--------------|
| A0-A17  | Address Inputs                    | Input  | Synchronous  |
| $\overline{CE}$   | Chip Enable                       | Input  | Synchronous  |
| CS0, $\overline{CS1}$   | Chip Selects                      | Input  | Synchronous  |
| $\overline{OE}$   | Output Enable                     | Input  | Asynchronous |
| $\overline{GW}$   | Global Write Enable               | Input  | Synchronous  |
| $\overline{BWE}$  | Byte Write Enable                 | Input  | Synchronous  |
| $\overline{BW1}$ , $\overline{BW2}$ , $\overline{BW3}$ , $\overline{BW4}^{(1)}$ | Individual Byte Write Selects     | Input  | Synchronous  |
| CLK   | Clock                             | Input  | N/A          |
| $\overline{ADV}$  | Burst Address Advance             | Input  | Synchronous  |
| $\overline{ADSC}$   | Address Status (Cache Controller) | Input  | Synchronous  |
| $\overline{ADSP}$   | Address Status (Processor)        | Input  | Synchronous  |
| $\overline{LBO}$  | Linear / Interleaved Burst Order  | Input  | DC           |
| TMS   | Test Mode Select                  | Input  | Synchronous  |
| TDI   | Test Data Input                   | Input  | Synchronous  |
| TCK   | Test Clock                        | Input  | N/A          |
| TDO   | Test Data Output                  | Output | Synchronous  |
| $\overline{TRST}$   | JTAG Reset (Optional)             | Input  | Asynchronous |
| ZZ  | Sleep Mode                        | Input  | Asynchronous |
| I/O0-I/O31, I/OP1-I/OP4   | Data Input / Output               | I/O    | Synchronous  |
| VDD, VDDQ   | Core Power, I/O Power             | Supply | N/A          |
| VSS   | Ground                            | Supply | N/A          |

5297 tbl 01

**MAY 2010**

## Pin Definitions<sup>(1)</sup>

| Symbol                              | Pin Function                      | I/O | Active | Description  |
|-------------------------------------|-----------------------------------|-----|--------|--|
| A0-A17                              | Address Inputs                    | I   | N/A    | Synchronous Address inputs. The address register is triggered by a combination of the rising edge of CLK and $\overline{ADSC}$ Low or $\overline{ADSP}$ Low and $\overline{CE}$ Low.   |
| $\overline{ADSC}$                   | Address Status (Cache Controller) | I   | LOW    | Synchronous Address Status from Cache Controller. $\overline{ADSC}$ is an active LOW input that is used to load the address registers with new addresses.  |
| $\overline{ADSP}$                   | Address Status (Processor)        | I   | LOW    | Synchronous Address Status from Processor. $\overline{ADSP}$ is an active LOW input that is used to load the address registers with new addresses. $\overline{ADSP}$ is gated by $\overline{CE}$ .   |
| $\overline{ADV}$                    | Burst Address Advance             | I   | LOW    | Synchronous Address Advance. $\overline{ADV}$ is an active LOW input that is used to advance the internal burst counter, controlling burst access after the initial address is loaded. When the input is HIGH the burst counter is not incremented; that is, there is no address advance.  |
| $\overline{BWE}$                    | Byte Write Enable                 | I   | LOW    | Synchronous byte write enable gates the byte write inputs $\overline{BW1}$ - $\overline{BW4}$ . If $\overline{BWE}$ is LOW at the rising edge of CLK then $\overline{BWx}$ inputs are passed to the next stage in the circuit. If $\overline{BWE}$ is HIGH then the byte write inputs are blocked and only $\overline{GW}$ can initiate a write cycle. |
| $\overline{BW1}$ - $\overline{BW4}$ | Individual Byte Write Enables     | I   | LOW    | Synchronous byte write enables. $\overline{BW1}$ controls I/O0-7, I/Op1, $\overline{BW2}$ controls I/O8-15, I/Op2, etc. Any active byte write causes all outputs to be disabled.   |
| $\overline{CE}$                     | Chip Enable                       | I   | LOW    | Synchronous chip enable. $\overline{CE}$ is used with CS0 and $\overline{CS1}$ to enable the IDT71V25761/781. $\overline{CE}$ also gates $\overline{ADSP}$ .   |
| CLK                                 | Clock                             | I   | N/A    | This is the clock input. All timing references for the device are made with respect to this input.   |
| CS0                                 | Chip Select 0                     | I   | HIGH   | Synchronous active HIGH chip select. CS0 is used with $\overline{CE}$ and $\overline{CS1}$ to enable the chip.   |
| $\overline{CS1}$                    | Chip Select 1                     | I   | LOW    | Synchronous active LOW chip select. $\overline{CS1}$ is used with $\overline{CE}$ and CS0 to enable the chip.  |
| $\overline{GW}$                     | Global Write Enable               | I   | LOW    | Synchronous global write enable. This input will write all four 9-bit data bytes when LOW on the rising edge of CLK. $\overline{GW}$ supersedes individual byte write enables.   |
| I/O0-I/O31<br>I/Op1-I/Op4           | Data Input/Output                 | I/O | N/A    | Synchronous data input/output (I/O) pins. Both the data input path and data output path are registered and triggered by the rising edge of CLK.  |
| $\overline{LBO}$                    | Linear Burst Order                | I   | LOW    | Asynchronous burst order selection input. When $\overline{LBO}$ is HIGH, the interleaved burst sequence is selected. When $\overline{LBO}$ is LOW the Linear burst sequence is selected. $\overline{LBO}$ is a static input and must not change state while the device is operating.   |
| $\overline{OE}$                     | Output Enable                     | I   | LOW    | Asynchronous output enable. When $\overline{OE}$ is LOW the data output drivers are enabled on the I/O pins if the chip is also selected. When $\overline{OE}$ is HIGH the I/O pins are in a high-impedance state.   |
| TMS                                 | Test ModeSelect                   | I   | N/A    | Gives input command for TAP controller. Sampled on rising edge of TDK. This pin has an internal pullup.  |
| TDI                                 | Test Data Input                   | I   | N/A    | Serial input of registers placed between TDI and TDO. Sampled on rising edge of TCK. This pin has an internal pullup.  |
| TCK                                 | Test Clock                        | I   | N/A    | Clock input of TAP controller. Each TAP event is clocked. Test inputs are captured on rising edge of TCK, while test outputs are driven from the falling edge of TCK. This pin has an internal pullup.   |
| TDO                                 | Test DataOutput                   | O   | N/A    | Serial output of registers placed between TDI and TDO. This output is active depending on the state of the TAP controller.   |
| $\overline{TRST}$                   | JTAG Reset (Optional)             | I   | LOW    | Optional Asynchronous JTAG reset. Can be used to reset the TAP controller, but not required. JTAG reset occurs automatically at power up and also resets using TMS and TCK per IEEE 1149.1. If not used $\overline{TRST}$ can be left floating. This pin has an internal pullup. Only available in BGA package.  |
| ZZ                                  | Sleep Mode                        | I   | HIGH   | Asynchronous sleep mode input. ZZ HIGH will gate the CLK internally and power down the IDT71V25761/781 to its lowest power consumption level. Data retention is guaranteed in Sleep Mode. This pin has an internal pull down.  |
| VDD                                 | Power Supply                      | N/A | N/A    | 3.3V core power supply.  |
| VDDQ                                | Power Supply                      | N/A | N/A    | 2.5V I/O Supply.   |
| VSS                                 | Ground                            | N/A | N/A    | Ground.  |
| NC                                  | No Connect                        | N/A | N/A    | NC pins are not electrically connected to the device.  |

**NOTE:**

5297 t01 02

1. All synchronous inputs must meet specified setup and hold times with respect to CLK.

## Functional Block Diagram

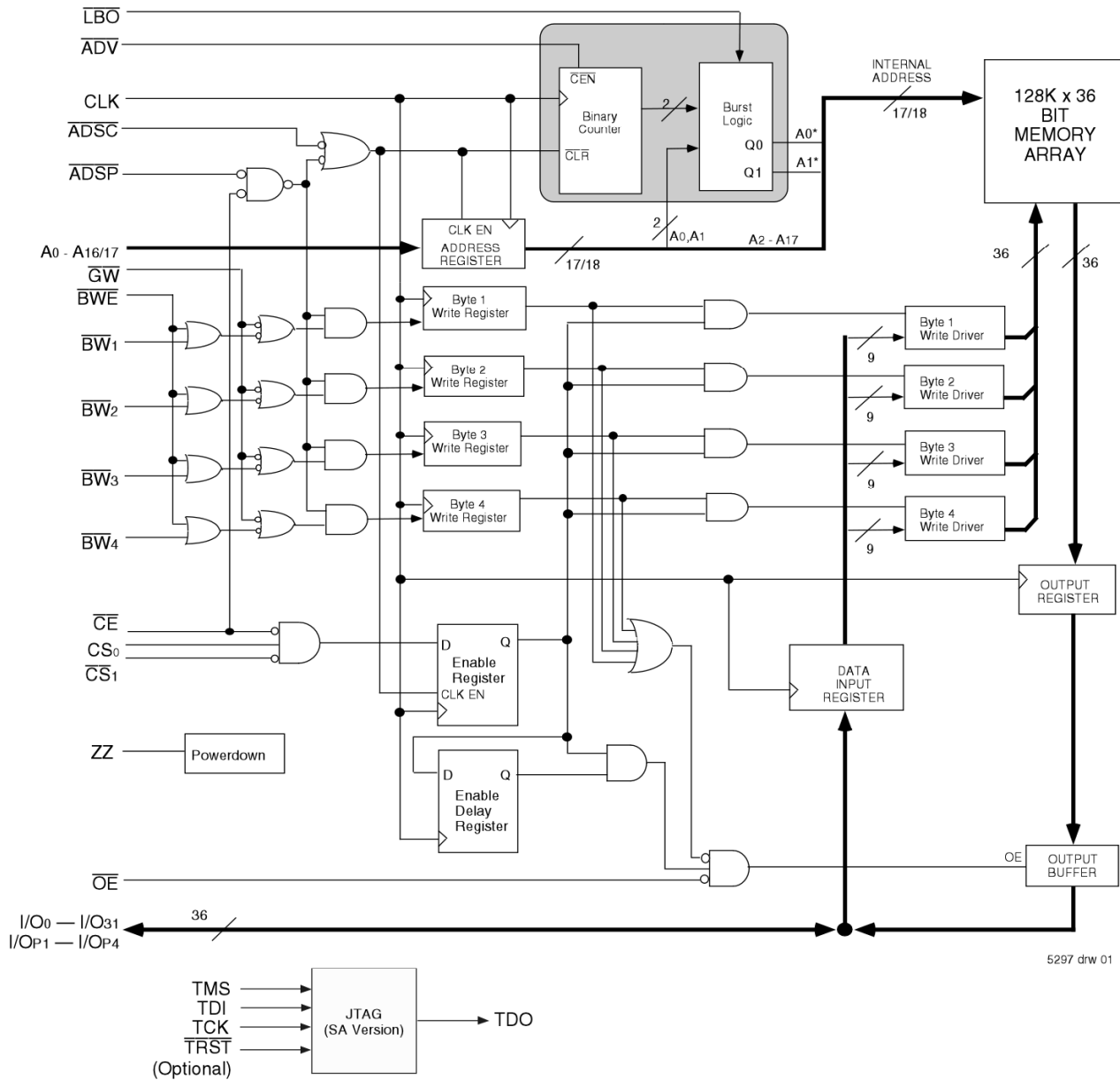

## Absolute Maximum Ratings<sup>(1)</sup>

| Symbol                             | Rating                               | Commercial & Industrial       | Unit |
|------------------------------------|--------------------------------------|-------------------------------|------|
| V <sub>TERM</sub> <sup>(2)</sup>   | Terminal Voltage with Respect to GND | -0.5 to +4.6                  | V    |
| V <sub>TERM</sub> <sup>(3,6)</sup> | Terminal Voltage with Respect to GND | -0.5 to V <sub>DD</sub>       | V    |
| V <sub>TERM</sub> <sup>(4,6)</sup> | Terminal Voltage with Respect to GND | -0.5 to V <sub>DD</sub> +0.5  | V    |
| V <sub>TERM</sub> <sup>(5,6)</sup> | Terminal Voltage with Respect to GND | -0.5 to V <sub>DDQ</sub> +0.5 | V    |
| T <sub>A</sub> <sup>(7)</sup>      | Commercial Operating Temperature     | -0 to +70                     | °C   |
|                                    | Industrial Operating Temperature     | -40 to +85                    | °C   |
| T <sub>BIAS</sub>                  | Temperature Under Bias               | -55 to +125                   | °C   |
| T <sub>STG</sub>                   | Storage Temperature                  | -55 to +125                   | °C   |
| P <sub>T</sub>                     | Power Dissipation                    | 2.0                           | W    |
| I <sub>OUT</sub>                   | DC Output Current                    | 50                            | mA   |

5297 tbl 03

### NOTES:

- Stresses greater than those listed under ABSOLUTE MAXIMUM RATINGS may cause permanent damage to the device. This is a stress rating only and functional operation of the device at these or any other conditions above those indicated in the operational sections of this specification is not implied. Exposure to absolute maximum rating conditions for extended periods may affect reliability.
- V<sub>DD</sub> terminals only.
- V<sub>DDQ</sub> terminals only.
- Input terminals only.
- I/O terminals only.
- This is a steady-state DC parameter that applies after the power supplies have ramped up. Power supply sequencing is not necessary; however, the voltage on any input or I/O pin cannot exceed V<sub>DDQ</sub> during power supply ramp up.
- T<sub>A</sub> is the "instant on" case temperature.

## 100 pin TQFP Capacitance

(T<sub>A</sub> = +25°C, f = 1.0MHz)

| Symbol          | Parameter <sup>(1)</sup> | Conditions             | Max. | Unit |
|-----------------|--------------------------|------------------------|------|------|
| C <sub>IN</sub> | Input Capacitance        | V <sub>IN</sub> = 3dV  | 5    | pF   |
| C <sub>VO</sub> | I/O Capacitance          | V <sub>OUT</sub> = 3dV | 7    | pF   |

5297 tbl 07

## 165 fBGA Capacitance

(T<sub>A</sub> = +25°C, f = 1.0MHz)

| Symbol          | Parameter <sup>(1)</sup> | Conditions             | Max. | Unit |
|-----------------|--------------------------|------------------------|------|------|
| C <sub>IN</sub> | Input Capacitance        | V <sub>IN</sub> = 3dV  | 7    | pF   |
| C <sub>VO</sub> | I/O Capacitance          | V <sub>OUT</sub> = 3dV | 7    | pF   |

5297 tbl 07b

### NOTE:

- This parameter is guaranteed by device characterization, but not production tested.

## Recommended Operating Temperature and Supply Voltage

| Grade      | Temperature <sup>(1)</sup> | V <sub>SS</sub> | V <sub>DD</sub> | V <sub>DDQ</sub> |
|------------|----------------------------|-----------------|-----------------|------------------|
| Commercial | 0°C to +70°C               | 0V              | 3.3V±5%         | 2.5V±5%          |
| Industrial | -40°C to +85°C             | 0V              | 3.3V±5%         | 2.5V±5%          |

### NOTES:

5297 tbl 04

- T<sub>A</sub> is the "instant on" case temperature.

## Recommended DC Operating Conditions

| Symbol           | Parameter                   | Min.                | Typ. | Max.                                 | Unit |
|------------------|-----------------------------|---------------------|------|--------------------------------------|------|
| V <sub>DD</sub>  | Core Supply Voltage         | 3.135               | 3.3  | 3.465                                | V    |
| V <sub>DDQ</sub> | I/O Supply Voltage          | 2.375               | 2.5  | 2.625                                | V    |
| V <sub>SS</sub>  | Supply Voltage              | 0                   | 0    | 0                                    | V    |
| V <sub>IH</sub>  | Input High Voltage - Inputs | 1.7                 | —    | V <sub>DD</sub> +0.3                 | V    |
| V <sub>IH</sub>  | Input High Voltage - I/O    | 1.7                 | —    | V <sub>DDQ</sub> +0.3 <sup>(1)</sup> | V    |
| V <sub>IL</sub>  | Input Low Voltage           | -0.3 <sup>(2)</sup> | —    | 0.7                                  | V    |

### NOTES:

5297 tbl 05

- V<sub>IH</sub> (max) = V<sub>DDQ</sub> + 1.0V for pulse width less than t<sub>CYC/2</sub>, once per cycle.
- V<sub>IL</sub> (min) = -1.0V for pulse width less than t<sub>CYC/2</sub>, once per cycle.

## 119 BGA Capacitance

(T<sub>A</sub> = +25°C, f = 1.0MHz)

| Symbol          | Parameter <sup>(1)</sup> | Conditions             | Max. | Unit |
|-----------------|--------------------------|------------------------|------|------|
| C <sub>IN</sub> | Input Capacitance        | V <sub>IN</sub> = 3dV  | 7    | pF   |
| C <sub>VO</sub> | I/O Capacitance          | V <sub>OUT</sub> = 3dV | 7    | pF   |

5297 tbl 07a

## Pin Configuration – 128K x 36

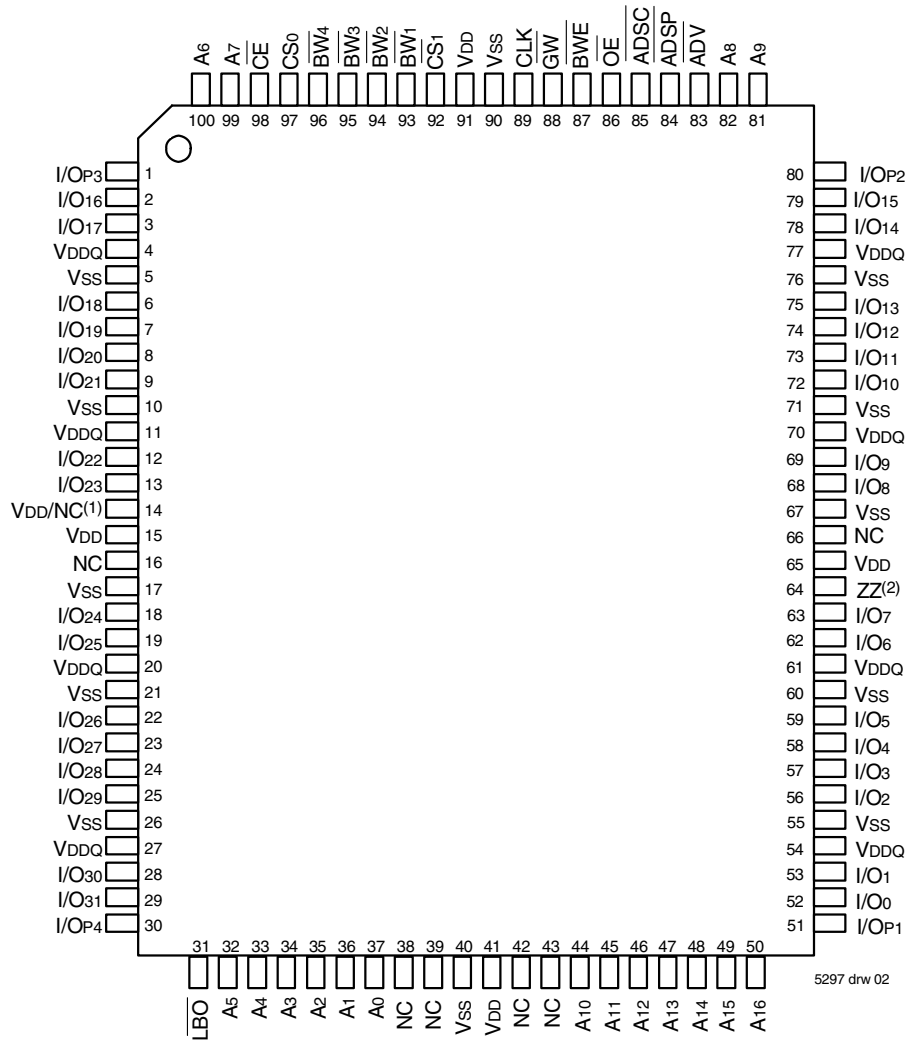

### 100 TQFP Top View

**NOTES:**

1. Pin 14 can either be directly connected to VDD, or connected to an input voltage  $\geq V_{IH}$ , or left unconnected.
2. Pin 64 can be left unconnected and the device will always remain in active mode.

## Pin Configuration – 128K x 36, 119 BGA

|   | 1     | 2                     | 3                     | 4                     | 5                       | 6                        | 7                 |
|---|-------|-----------------------|-----------------------|-----------------------|-------------------------|--------------------------|-------------------|
| A | VDDQ  | A6                    | A4                    | ADSP                  | A8                      | A16                      | VDDQ              |
| B | NC    | CS <sub>0</sub>       | A3                    | ADSC                  | A9                      | CS <sub>1</sub>          | NC                |
| C | NC    | A7                    | A2                    | VDD                   | A12                     | A15                      | NC                |
| D | I/O16 | I/OP3                 | VSS                   | NC                    | VSS                     | I/OP2                    | I/O15             |
| E | I/O17 | I/O18                 | VSS                   | CE                    | VSS                     | I/O13                    | I/O14             |
| F | VDDQ  | I/O19                 | VSS                   | OE                    | VSS                     | I/O12                    | VDDQ              |
| G | I/O20 | I/O21                 | BW <sub>3</sub>       | ADV                   | BW <sub>2</sub>         | I/O11                    | I/O10             |
| H | I/O22 | I/O23                 | VSS                   | GW                    | VSS                     | I/O9                     | I/O8              |
| J | VDDQ  | VDD                   | NC                    | VDD                   | NC                      | VDD                      | VDDQ              |
| K | I/O24 | I/O26                 | VSS                   | CLK                   | VSS                     | I/O6                     | I/O7              |
| L | I/O25 | I/O27                 | BW <sub>4</sub>       | NC                    | BW <sub>1</sub>         | I/O4                     | I/O5              |
| M | VDDQ  | I/O28                 | VSS                   | BWE                   | VSS                     | I/O3                     | VDDQ              |
| N | I/O29 | I/O30                 | VSS                   | A1                    | VSS                     | I/O2                     | I/O1              |
| P | I/O31 | I/OP4                 | VSS                   | A0                    | VSS                     | I/O0                     | I/OP1             |
| R | NC    | A5                    | LBO                   | VDD                   | VDD / NC <sup>(1)</sup> | A13                      | NC                |
| T | NC    | NC                    | A10                   | A11                   | A14                     | NC                       | ZZ <sup>(3)</sup> |
| U | VDDQ  | NC/TMS <sup>(2)</sup> | NC/TDI <sup>(2)</sup> | NC/TCK <sup>(2)</sup> | NC/TDO <sup>(2)</sup>   | NC/TRST <sup>(2,4)</sup> | VDDQ              |

5297 drw 04

### Top View

#### NOTES:

1. R5 can either be directly connected to VDD, or connected to an input voltage  $\geq V_{IH}$ , or left unconnected.
2. These pins are NC for the "S" version or the JTAG signal listed for the "SA" version. Note: If NC, these pins can either be tied to Vss, Vdd or left floating.
3. T7 can be left unconnected and the device will always remain in active mode.
4.  $\overline{\text{TRST}}$  is offered as an optional JTAG Reset if required in the application. If not needed, can be left floating and will internally be pulled to Vdd.

## Pin Configuration – 128K x 36, 165 fBGA

|   | 1                  | 2                 | 3                 | 4                 | 5                                      | 6                 | 7                     | 8                 | 9                 | 10    | 11                |
|---|--------------------|-------------------|-------------------|-------------------|--|-------------------|-----------------------|-------------------|-------------------|-------|-------------------|
| A | NC <sup>(4)</sup>  | A7                | $\overline{CE}_1$ | $\overline{BW}_3$ | $\overline{BW}_2$                      | $\overline{CS}_1$ | $\overline{BWE}$      | $\overline{ADSC}$ | $\overline{ADV}$  | A8    | NC                |
| B | NC                 | A6                | CS0               | $\overline{BW}_4$ | $\overline{BW}_1$                      | CLK               | $\overline{GW}$       | $\overline{OE}$   | $\overline{ADSP}$ | A9    | NC <sup>(4)</sup> |
| C | I/OP3              | NC                | VDDQ              | VSS               | VSS                                    | VSS               | VSS                   | VSS               | VDDQ              | NC    | I/OP2             |
| D | I/O17              | I/O16             | VDDQ              | VDD               | VSS                                    | VSS               | VSS                   | VDD               | VDDQ              | I/O15 | I/O14             |
| E | I/O19              | I/O18             | VDDQ              | VDD               | VSS                                    | VSS               | VSS                   | VDD               | VDDQ              | I/O13 | I/O12             |
| F | I/O21              | I/O20             | VDDQ              | VDD               | VSS                                    | VSS               | VSS                   | VDD               | VDDQ              | I/O11 | I/O10             |
| G | I/O23              | I/O22             | VDDQ              | VDD               | VSS                                    | VSS               | VSS                   | VDD               | VDDQ              | I/O9  | I/O8              |
| H | VDD <sup>(1)</sup> | NC                | NC                | VDD               | VSS                                    | VSS               | VSS                   | VDD               | NC                | NC    | ZZ <sup>(3)</sup> |
| J | I/O25              | I/O24             | VDDQ              | VDD               | VSS                                    | VSS               | VSS                   | VDD               | VDDQ              | I/O7  | I/O6              |
| K | I/O27              | I/O26             | VDDQ              | VDD               | VSS                                    | VSS               | VSS                   | VDD               | VDDQ              | I/O5  | I/O4              |
| L | I/O29              | I/O28             | VDDQ              | VDD               | VSS                                    | VSS               | VSS                   | VDD               | VDDQ              | I/O3  | I/O2              |
| M | I/O31              | I/O30             | VDDQ              | VDD               | VSS                                    | VSS               | VSS                   | VDD               | VDDQ              | I/O1  | I/O0              |
| N | I/OP4              | NC                | VDDQ              | VSS               | NC/ $\overline{TRST}$ <sup>(2,5)</sup> | NC <sup>(4)</sup> | NC                    | VSS               | VDDQ              | NC    | I/OP1             |
| P | NC                 | NC <sup>(4)</sup> | A5                | A2                | NC/TDI <sup>(2)</sup>                  | A1                | NC/TDO <sup>(2)</sup> | A10               | A13               | A14   | NC <sup>(4)</sup> |
| R | $\overline{LB}_0$  | NC <sup>(4)</sup> | A4                | A3                | NC/TMS <sup>(2)</sup>                  | A0                | NC/TCK <sup>(2)</sup> | A11               | A12               | A15   | A16               |

5297 tbl 17

### NOTES:

- H1 can either be directly connected to VDD, or connected to an input voltage  $\geq V_{IH}$ , or left unconnected.
- These pins are NC for the "S" version or the JTAG signal listed for the "SA" version. Note: If NC, these pins can either be tied to VSS, VDD or left floating.
- H11 can be left unconnected and the device will always remain in active mode.
- Pins P11, N6, B11, A1, R2 and P2 are reserved for 9M, 18M, 36M, 72M, 144M and 288M respectively.
- $\overline{TRST}$  is offered as an optional JTAG Reset if required in the application. If not needed, can be left floating and will internally be pulled to VDD.

## DC Electrical Characteristics Over the Operating Temperature and Supply Voltage Range ( $V_{DD} = 3.3V \pm 5\%$ )

| Symbol    | Parameter  | Test Conditions  | Min. | Max. | Unit    |
|-----------|--|--|------|------|---------|
| $I_{LIL}$ | Input Leakage Current  | $V_{DD} = \text{Max.}, V_{IN} = 0V \text{ to } V_{DD}$ | —    | 5    | $\mu A$ |
| $I_{LZZ}$ | ZZ, $\overline{LBO}$ and JTAG Input Leakage Current <sup>(1)</sup> | $V_{DD} = \text{Max.}, V_{IN} = 0V \text{ to } V_{DD}$ | —    | 30   | $\mu A$ |
| $I_{LOL}$ | Output Leakage Current   | $V_{OUT} = 0V \text{ to } V_{DDQ}$ , Device Deselected | —    | 5    | $\mu A$ |
| $V_{OL}$  | Output Low Voltage   | $I_{OL} = +6mA, V_{DD} = \text{Min.}$                  | —    | 0.4  | V       |
| $V_{OH}$  | Output High Voltage  | $I_{OH} = -6mA, V_{DD} = \text{Min.}$                  | 2.0  | —    | V       |

5297 tbl 08

**NOTE:**

- The  $\overline{LBO}$ , TMS, TDI, TCK and TRST pins will be internally pulled to  $V_{DD}$  and the ZZ pin will be internally pulled to  $V_{SS}$  if they are not actively driven in the application.

## DC Electrical Characteristics Over the Operating Temperature and Supply Voltage Range<sup>(1)</sup>

| Symbol    | Parameter                          | Test Conditions   | 200MHz     |       | 183MHz |       | 166MHz |    | Unit |
|-----------|------------------------------------|---|------------|-------|--------|-------|--------|----|------|
|           |                                    |   | Com'l Only | Com'l | Ind    | Com'l | Ind    |    |      |
| $I_{DD}$  | Operating Power Supply Current     | Device Selected, Outputs Open, $V_{DD} = \text{Max.}, V_{DDQ} = \text{Max.}, V_{IN} \geq V_{IH} \text{ or } \leq V_{IL}, f = f_{MAX}^{(2)}$     | 360        | 340   | 350    | 320   | 330    | mA |      |
| $I_{SB1}$ | CMOS Standby Power Supply Current  | Device Deselected, Outputs Open, $V_{DD} = \text{Max.}, V_{DDQ} = \text{Max.}, V_{IN} \geq V_{HD} \text{ or } \leq V_{LD}, f = 0^{(2,3)}$       | 30         | 30    | 35     | 30    | 35     | mA |      |
| $I_{SB2}$ | Clock Running Power Supply Current | Device Deselected, Outputs Open, $V_{DD} = \text{Max.}, V_{DDQ} = \text{Max.}, V_{IN} \geq V_{HD} \text{ or } \leq V_{LD}, f = f_{MAX}^{(2,3)}$ | 130        | 120   | 130    | 110   | 120    | mA |      |
| $I_{ZZ}$  | Full Sleep Mode Supply Current     | $ZZ \geq V_{HD}, V_{DD} = \text{Max.}$  | 30         | 30    | 35     | 30    | 35     | mA |      |

5297 tbl 09

**NOTES:**

- All values are maximum guaranteed values.
- At  $f = f_{MAX}$ , inputs are cycling at the maximum frequency of read cycles of  $1/t_{CYC}$  while  $\overline{ADSC} = \text{LOW}$ ;  $f=0$  means no input lines are changing.
- For I/Os  $V_{HD} = V_{DDQ} - 0.2V, V_{LD} = 0.2V$ . For other inputs  $V_{HD} = V_{DD} - 0.2V, V_{LD} = 0.2V$ .

## AC Test Conditions ( $V_{DDQ} = 2.5V$ )

|                                |               |
|--------------------------------|---------------|
| Input Pulse Levels             | 0 to 2.5V     |
| Input Rise/Fall Times          | 2ns           |
| Input Timing Reference Levels  | $(V_{DDQ}/2)$ |
| Output Timing Reference Levels | $(V_{DDQ}/2)$ |
| AC Test Load                   | See Figure 1  |

5297 tbl 10

## AC Test Load

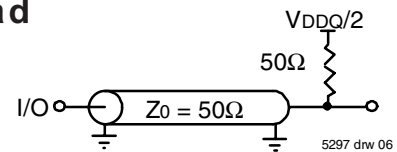

Figure 1. AC Test Load

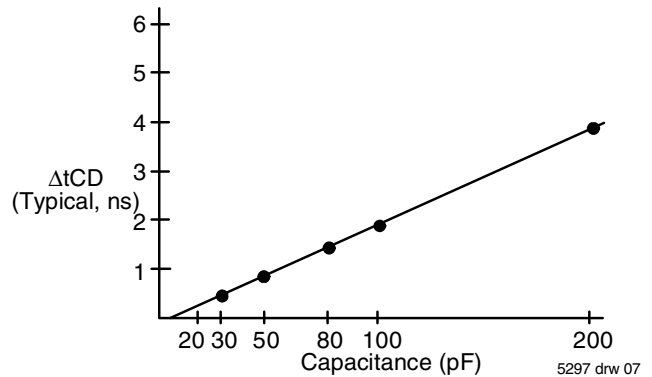

Figure 2. Lumped Capacitive Load, Typical Derating

## Synchronous Truth Table<sup>(1,3)</sup>

| Operation                    | Address Used | $\overline{CE}$ | $CS_0$ | $\overline{CS}_1$ | $\overline{ADSP}$ | $\overline{ADSC}$ | $\overline{ADV}$ | $\overline{GW}$ | $\overline{BWE}$ | $\overline{BW}_x$ | $\overline{OE}$ (2) | CLK | I/O  |
|------------------------------|--------------|-----------------|--------|-------------------|-------------------|-------------------|------------------|-----------------|------------------|-------------------|---------------------|-----|------|
| Deselected Cycle, Power Down | None         | H               | X      | X                 | X                 | L                 | X                | X               | X                | X                 | X                   | -   | HI-Z |
| Deselected Cycle, Power Down | None         | L               | X      | H                 | L                 | X                 | X                | X               | X                | X                 | X                   | -   | HI-Z |
| Deselected Cycle, Power Down | None         | L               | L      | X                 | L                 | X                 | X                | X               | X                | X                 | X                   | -   | HI-Z |
| Deselected Cycle, Power Down | None         | L               | X      | H                 | X                 | L                 | X                | X               | X                | X                 | X                   | -   | HI-Z |
| Deselected Cycle, Power Down | None         | L               | L      | X                 | X                 | L                 | X                | X               | X                | X                 | X                   | -   | HI-Z |
| Read Cycle, Begin Burst      | External     | L               | H      | L                 | L                 | X                 | X                | X               | X                | X                 | L                   | -   | DOUT |
| Read Cycle, Begin Burst      | External     | L               | H      | L                 | L                 | X                 | X                | X               | X                | X                 | H                   | -   | HI-Z |
| Read Cycle, Begin Burst      | External     | L               | H      | L                 | H                 | L                 | X                | H               | H                | X                 | L                   | -   | DOUT |
| Read Cycle, Begin Burst      | External     | L               | H      | L                 | H                 | L                 | X                | H               | L                | H                 | L                   | -   | DOUT |
| Read Cycle, Begin Burst      | External     | L               | H      | L                 | H                 | L                 | X                | H               | L                | H                 | H                   | -   | HI-Z |
| Write Cycle, Begin Burst     | External     | L               | H      | L                 | H                 | L                 | X                | H               | L                | L                 | X                   | -   | DIN  |
| Write Cycle, Begin Burst     | External     | L               | H      | L                 | H                 | L                 | X                | L               | X                | X                 | X                   | -   | DIN  |
| Read Cycle, Continue Burst   | Next         | X               | X      | X                 | H                 | H                 | L                | H               | H                | X                 | L                   | -   | DOUT |
| Read Cycle, Continue Burst   | Next         | X               | X      | X                 | H                 | H                 | L                | H               | H                | X                 | H                   | -   | HI-Z |
| Read Cycle, Continue Burst   | Next         | X               | X      | X                 | H                 | H                 | L                | H               | X                | H                 | L                   | -   | DOUT |
| Read Cycle, Continue Burst   | Next         | X               | X      | X                 | H                 | H                 | L                | H               | X                | H                 | H                   | -   | HI-Z |
| Read Cycle, Continue Burst   | Next         | H               | X      | X                 | X                 | H                 | L                | H               | H                | X                 | L                   | -   | DOUT |
| Read Cycle, Continue Burst   | Next         | H               | X      | X                 | X                 | H                 | L                | H               | H                | X                 | H                   | -   | HI-Z |
| Read Cycle, Continue Burst   | Next         | H               | X      | X                 | X                 | H                 | L                | H               | X                | H                 | L                   | -   | DOUT |
| Read Cycle, Continue Burst   | Next         | H               | X      | X                 | X                 | H                 | L                | H               | X                | H                 | H                   | -   | HI-Z |
| Write Cycle, Continue Burst  | Next         | X               | X      | X                 | H                 | H                 | L                | H               | L                | L                 | X                   | -   | DIN  |
| Write Cycle, Continue Burst  | Next         | X               | X      | X                 | H                 | H                 | L                | L               | X                | X                 | X                   | -   | DIN  |
| Write Cycle, Continue Burst  | Next         | H               | X      | X                 | X                 | H                 | L                | H               | L                | L                 | X                   | -   | DIN  |
| Write Cycle, Continue Burst  | Next         | H               | X      | X                 | X                 | H                 | L                | L               | X                | X                 | X                   | -   | DIN  |
| Read Cycle, Suspend Burst    | Current      | X               | X      | X                 | H                 | H                 | H                | H               | H                | X                 | L                   | -   | DOUT |
| Read Cycle, Suspend Burst    | Current      | X               | X      | X                 | H                 | H                 | H                | H               | H                | X                 | H                   | -   | HI-Z |
| Read Cycle, Suspend Burst    | Current      | X               | X      | X                 | H                 | H                 | H                | H               | X                | H                 | L                   | -   | DOUT |
| Read Cycle, Suspend Burst    | Current      | X               | X      | X                 | H                 | H                 | H                | H               | X                | H                 | H                   | -   | HI-Z |
| Read Cycle, Suspend Burst    | Current      | H               | X      | X                 | X                 | H                 | H                | H               | H                | X                 | L                   | -   | DOUT |
| Read Cycle, Suspend Burst    | Current      | H               | X      | X                 | X                 | H                 | H                | H               | H                | X                 | H                   | -   | HI-Z |
| Read Cycle, Suspend Burst    | Current      | H               | X      | X                 | X                 | H                 | H                | H               | X                | H                 | L                   | -   | DOUT |
| Read Cycle, Suspend Burst    | Current      | H               | X      | X                 | X                 | H                 | H                | H               | X                | H                 | H                   | -   | HI-Z |
| Write Cycle, Suspend Burst   | Current      | X               | X      | X                 | H                 | H                 | H                | H               | L                | L                 | X                   | -   | DIN  |
| Write Cycle, Suspend Burst   | Current      | X               | X      | X                 | H                 | H                 | H                | L               | X                | X                 | X                   | -   | DIN  |
| Write Cycle, Suspend Burst   | Current      | H               | X      | X                 | X                 | H                 | H                | H               | L                | L                 | X                   | -   | DIN  |
| Write Cycle, Suspend Burst   | Current      | H               | X      | X                 | X                 | H                 | H                | L               | X                | X                 | X                   | -   | DIN  |

**NOTES:**

1. L =  $V_{IL}$ , H =  $V_{IH}$ , X = Don't Care.
2.  $\overline{OE}$  is an asynchronous input.
3. ZZ = low for this table.

5297 tbl 11

### Synchronous Write Function Truth Table<sup>(1)</sup>

| Operation                   | $\overline{G\overline{W}}$ | $\overline{B\overline{W}E}$ | $\overline{B\overline{W}}_1$ | $\overline{B\overline{W}}_2$ | $\overline{B\overline{W}}_3$ | $\overline{B\overline{W}}_4$ |
|-----------------------------|----------------------------|-----------------------------|------------------------------|------------------------------|------------------------------|------------------------------|
| Read                        | H                          | H                           | X                            | X                            | X                            | X                            |
| Read                        | H                          | L                           | H                            | H                            | H                            | H                            |
| Write all Bytes             | L                          | X                           | X                            | X                            | X                            | X                            |
| Write all Bytes             | H                          | L                           | L                            | L                            | L                            | L                            |
| Write Byte 1 <sup>(3)</sup> | H                          | L                           | L                            | H                            | H                            | H                            |
| Write Byte 2 <sup>(3)</sup> | H                          | L                           | H                            | L                            | H                            | H                            |
| Write Byte 3 <sup>(3)</sup> | H                          | L                           | H                            | H                            | L                            | H                            |
| Write Byte 4 <sup>(3)</sup> | H                          | L                           | H                            | H                            | H                            | L                            |

5297 tbl 12

**NOTES:**

1. L =  $V_{IL}$ , H =  $V_{IH}$ , X = Don't Care.
3. Multiple bytes may be selected during the same cycle.

### Asynchronous Truth Table<sup>(1)</sup>

| Operation <sup>(2)</sup> | $\overline{O\overline{E}}$ | ZZ | I/O Status       | Power   |
|--------------------------|----------------------------|----|------------------|---------|
| Read                     | L                          | L  | Data Out         | Active  |
| Read                     | H                          | L  | High-Z           | Active  |
| Write                    | X                          | L  | High-Z – Data In | Active  |
| Deselected               | X                          | L  | High-Z           | Standby |
| Sleep Mode               | X                          | H  | High-Z           | Sleep   |

5297 tbl 13

**NOTES:**

1. L =  $V_{IL}$ , H =  $V_{IH}$ , X = Don't Care.
2. Synchronous function pins must be biased appropriately to satisfy operation requirements.

### Interleaved Burst Sequence Table ( $\overline{L\overline{B\overline{O}}}=V_{DD}$ )

|                               | Sequence 1 |    | Sequence 2 |    | Sequence 3 |    | Sequence 4 |    |
|-------------------------------|------------|----|------------|----|------------|----|------------|----|
|                               | A1         | A0 | A1         | A0 | A1         | A0 | A1         | A0 |
| First Address                 | 0          | 0  | 0          | 1  | 1          | 0  | 1          | 1  |
| Second Address                | 0          | 1  | 0          | 0  | 1          | 1  | 1          | 0  |
| Third Address                 | 1          | 0  | 1          | 1  | 0          | 0  | 0          | 1  |
| Fourth Address <sup>(1)</sup> | 1          | 1  | 1          | 0  | 0          | 1  | 0          | 0  |

5297 tbl 14

**NOTE:**

1. Upon completion of the Burst sequence the counter wraps around to its initial state.

### Linear Burst Sequence Table ( $\overline{L\overline{B\overline{O}}}=V_{SS}$ )

|                               | Sequence 1 |    | Sequence 2 |    | Sequence 3 |    | Sequence 4 |    |
|-------------------------------|------------|----|------------|----|------------|----|------------|----|
|                               | A1         | A0 | A1         | A0 | A1         | A0 | A1         | A0 |
| First Address                 | 0          | 0  | 0          | 1  | 1          | 0  | 1          | 1  |
| Second Address                | 0          | 1  | 1          | 0  | 1          | 1  | 0          | 0  |
| Third Address                 | 1          | 0  | 1          | 1  | 0          | 0  | 0          | 1  |
| Fourth Address <sup>(1)</sup> | 1          | 1  | 0          | 0  | 0          | 1  | 1          | 0  |

5297 tbl 15

**NOTE:**

1. Upon completion of the Burst sequence the counter wraps around to its initial state.

## AC Electrical Characteristics

(VDD = 3.3V ±5%, Commercial and Industrial Temperature Ranges)

| Symbol   | Parameter                           | 200MHz <sup>(5)</sup> |      | 183MHz |      | 166MHz |      | Unit |
|--|-------------------------------------|-----------------------|------|--------|------|--------|------|------|
|  |                                     | Min.                  | Max. | Min.   | Max. | Min.   | Max. |      |
| t <sub>CYC</sub>                               | Clock Cycle Time                    | 5                     | —    | 5.5    | —    | 6      | —    | ns   |
| t <sub>CH</sub> <sup>(1)</sup>                 | Clock High Pulse Width              | 2                     | —    | 2.2    | —    | 2.4    | —    | ns   |
| t <sub>CL</sub> <sup>(1)</sup>                 | Clock Low Pulse Width               | 2                     | —    | 2.2    | —    | 2.4    | —    | ns   |
| <b>Output Parameters</b>                       |                                     |                       |      |        |      |        |      |      |
| t <sub>CD</sub>                                | Clock High to Valid Data            | —                     | 3.1  | —      | 3.3  | —      | 3.5  | ns   |
| t <sub>DC</sub>                                | Clock High to Data Change           | 1.0                   | —    | 1.0    | —    | 1.0    | —    | ns   |
| t <sub>CLZ</sub> <sup>(2)</sup>                | Clock High to Output Active         | 0                     | —    | 0      | —    | 0      | —    | ns   |
| t <sub>CHZ</sub> <sup>(2)</sup>                | Clock High to Data High-Z           | 1.5                   | 3.1  | 1.5    | 3.3  | 1.5    | 3.5  | ns   |
| t <sub>OE</sub>                                | Output Enable Access Time           | —                     | 3.1  | —      | 3.3  | —      | 3.5  | ns   |
| t <sub>OLZ</sub> <sup>(2)</sup>                | Output Enable Low to Output Active  | 0                     | —    | 0      | —    | 0      | —    | ns   |
| t <sub>OHZ</sub> <sup>(2)</sup>                | Output Enable High to Output High-Z | —                     | 3.1  | —      | 3.3  | —      | 3.5  | ns   |
| <b>Set Up Times</b>                            |                                     |                       |      |        |      |        |      |      |
| t <sub>SA</sub>                                | Address Setup Time                  | 1.2                   | —    | 1.5    | —    | 1.5    | —    | ns   |
| t <sub>SS</sub>                                | Address Status Setup Time           | 1.2                   | —    | 1.5    | —    | 1.5    | —    | ns   |
| t <sub>SD</sub>                                | Data In Setup Time                  | 1.2                   | —    | 1.5    | —    | 1.5    | —    | ns   |
| t <sub>SW</sub>                                | Write Setup Time                    | 1.2                   | —    | 1.5    | —    | 1.5    | —    | ns   |
| t <sub>SAV</sub>                               | Address Advance Setup Time          | 1.2                   | —    | 1.5    | —    | 1.5    | —    | ns   |
| t <sub>SC</sub>                                | Chip Enable/Select Setup Time       | 1.2                   | —    | 1.5    | —    | 1.5    | —    | ns   |
| <b>Hold Times</b>                              |                                     |                       |      |        |      |        |      |      |
| t <sub>HA</sub>                                | Address Hold Time                   | 0.4                   | —    | 0.5    | —    | 0.5    | —    | ns   |
| t <sub>HS</sub>                                | Address Status Hold Time            | 0.4                   | —    | 0.5    | —    | 0.5    | —    | ns   |
| t <sub>HD</sub>                                | Data In Hold Time                   | 0.4                   | —    | 0.5    | —    | 0.5    | —    | ns   |
| t <sub>HW</sub>                                | Write Hold Time                     | 0.4                   | —    | 0.5    | —    | 0.5    | —    | ns   |
| t <sub>HAV</sub>                               | Address Advance Hold Time           | 0.4                   | —    | 0.5    | —    | 0.5    | —    | ns   |
| t <sub>HC</sub>                                | Chip Enable/Select Hold Time        | 0.4                   | —    | 0.5    | —    | 0.5    | —    | ns   |
| <b>Sleep Mode and Configuration Parameters</b> |                                     |                       |      |        |      |        |      |      |
| t <sub>ZZPW</sub>                              | ZZ Pulse Width                      | 100                   | —    | 100    | —    | 100    | —    | ns   |
| t <sub>ZZR</sub> <sup>(3)</sup>                | ZZ Recovery Time                    | 100                   | —    | 100    | —    | 100    | —    | ns   |
| t <sub>CFG</sub> <sup>(4)</sup>                | Configuration Set-up Time           | 20                    | —    | 22     | —    | 24     | —    | ns   |

4876 tbl 16

### NOTES:

1. Measured as HIGH above V<sub>IH</sub> and LOW below V<sub>IL</sub>.
2. Transition is measured ±200mV from steady-state.
3. Device must be deselected when powered-up from sleep mode.
4. t<sub>CFG</sub> is the minimum time required to configure the device based on the  $\overline{\text{LBO}}$  input.  $\overline{\text{LBO}}$  is a static input and must not change during normal operation.
5. Commercial temperature range only.

Timing Waveform of Pipeline Read Cycle (1,2)

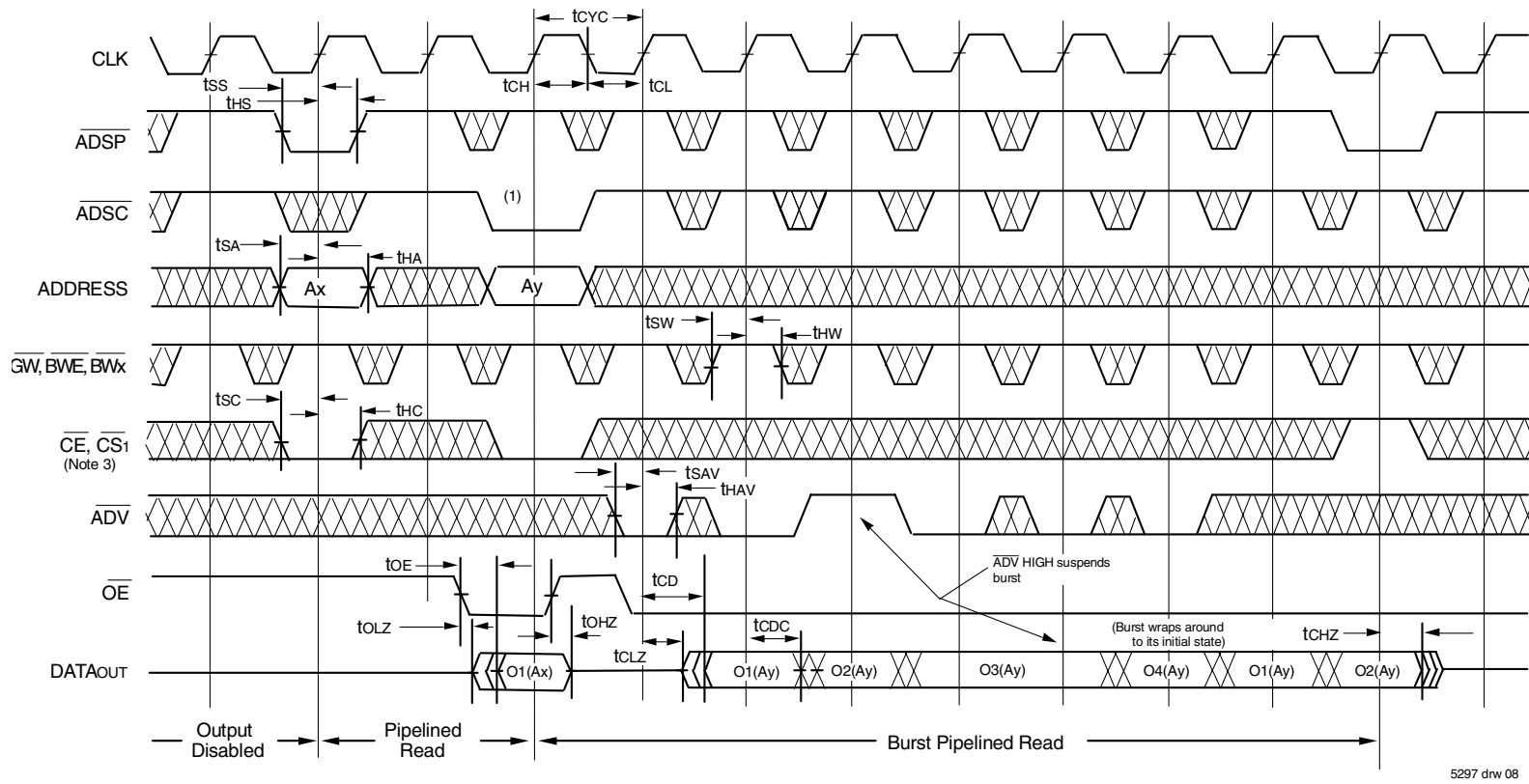

5297 dnr 08

NOTES:

1. O1 (Ax) represents the first output from the external address Ax. O1 (Ay) represents the first output from the external address Ay; O2 (Ay) represents the next output data in the burst sequence of the base address Ay, etc. where A0 and A1 are advancing for the four word burst in the sequence defined by the state of the LBO input.
2. ZZ input is LOW and  $\overline{LBO}$  is Don't Care for this cycle.
3. CS0 timing transitions are identical but inverted to the  $\overline{CE}$  and  $\overline{CS1}$  signals. For example, when  $\overline{CE}$  and  $\overline{CS1}$  are LOW on this waveform, CS0 is HIGH.

Timing Waveform of Combined Pipelined Read and Write Cycles (1,2,3)

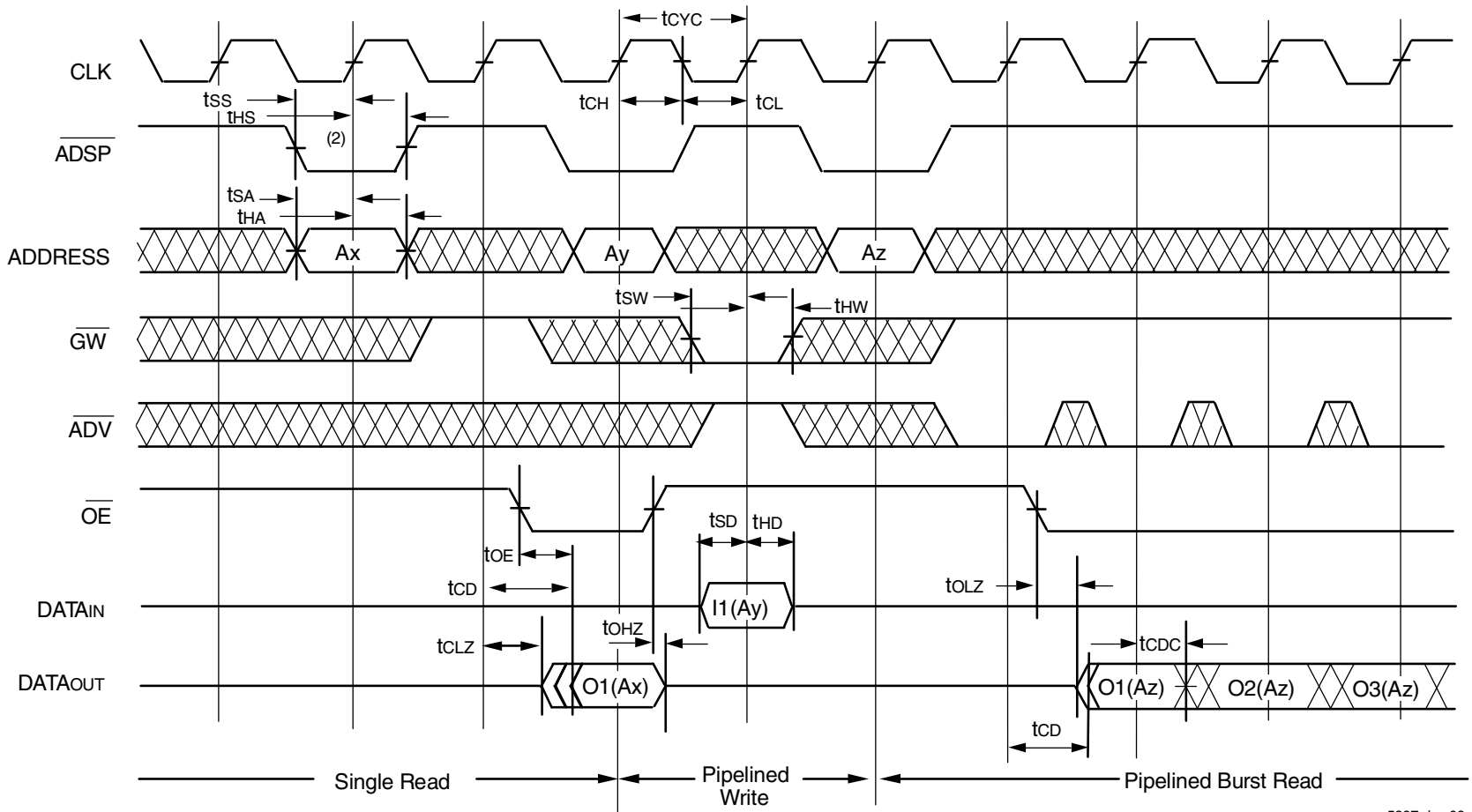

5297 drw 09

NOTES:

1. Device is selected through entire cycle;  $\overline{CE}$  and  $\overline{CS}1$  are LOW,  $CS0$  is HIGH.
2.  $\overline{ZZ}$  input is LOW and  $\overline{LBO}$  is Don't Care for this cycle.
3.  $O1(Ax)$  represents the first output from the external address  $Ax$ ;  $I1(Ay)$  represents the first input from the external address  $Ay$ ;  $O1(Az)$  represents the first output from the external address  $Az$ ;  $O2(Az)$  represents the next output data in the burst sequence of the base address  $Az$ , etc. where  $A0$  and  $A1$  are advancing for the four word burst in the sequence defined by the state of the  $\overline{LBO}$  input.

Timing Waveform of Write Cycle No. 1 — GW Controlled (1,2,3)

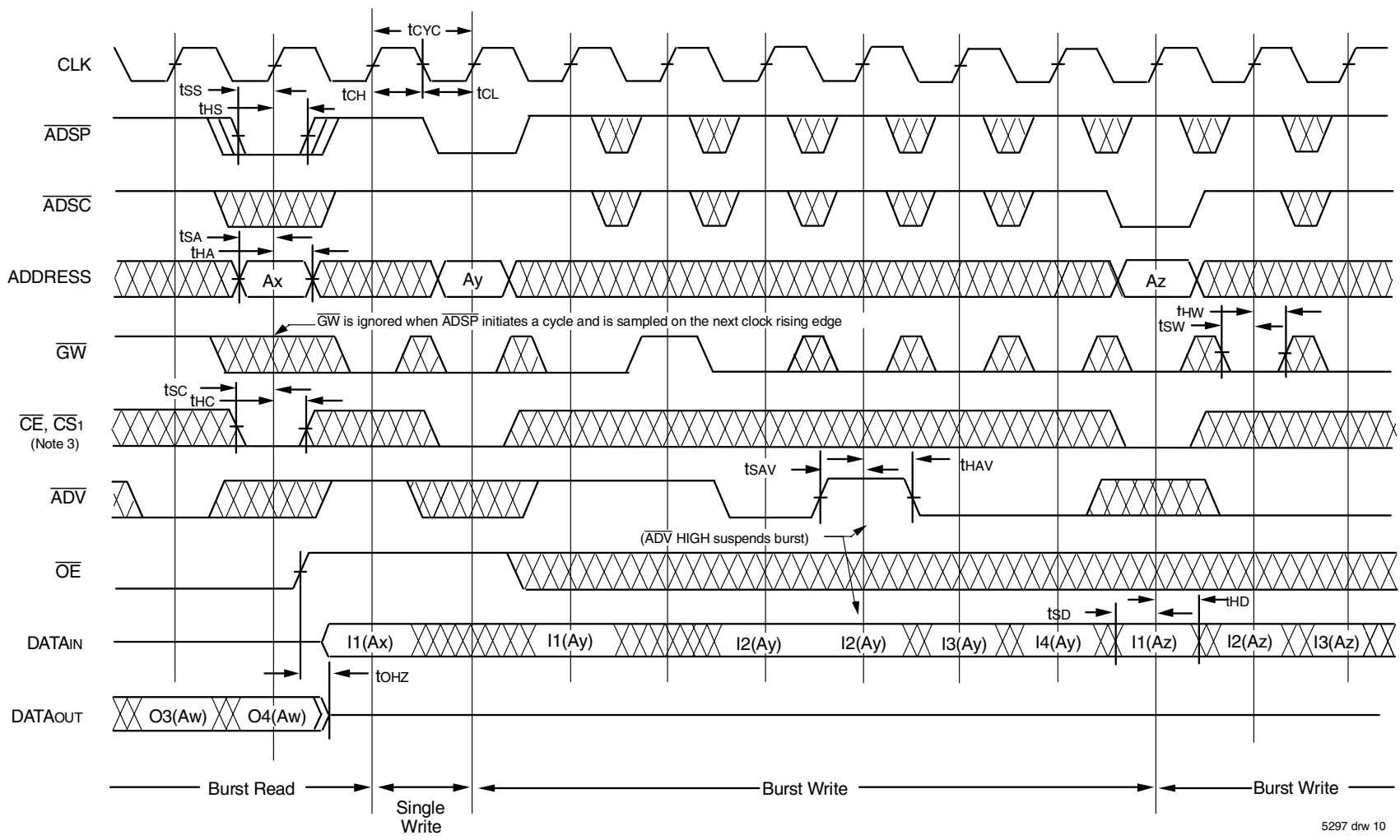

5297 drw 10

NOTES:

1. ZZ input is LOW, BWE is HIGH and LBO is Don't Care for this cycle.
2. O4 (Aw) represents the final output data in the burst sequence of the base address Aw. I1 (Ax) represents the first input from the external address Ax. I1 (Ay) represents the first input from the external address Ay; I2 (Ay) represents the next input data in the burst sequence of the base address Ay, etc. where A0 and A1 are advancing for the four word burst in the sequence defined by the state of the LBO input. In the case of input I2 (Ay) this data is valid for two cycles because ADV is high and has suspended the burst.
3. CS0 timing transitions are identical but inverted to the CE and CS1 signals. For example, when CE and CS1 are LOW on this waveform, CS0 is HIGH.

Timing Waveform of Write Cycle No. 2 — Byte Controlled(1,2,3)

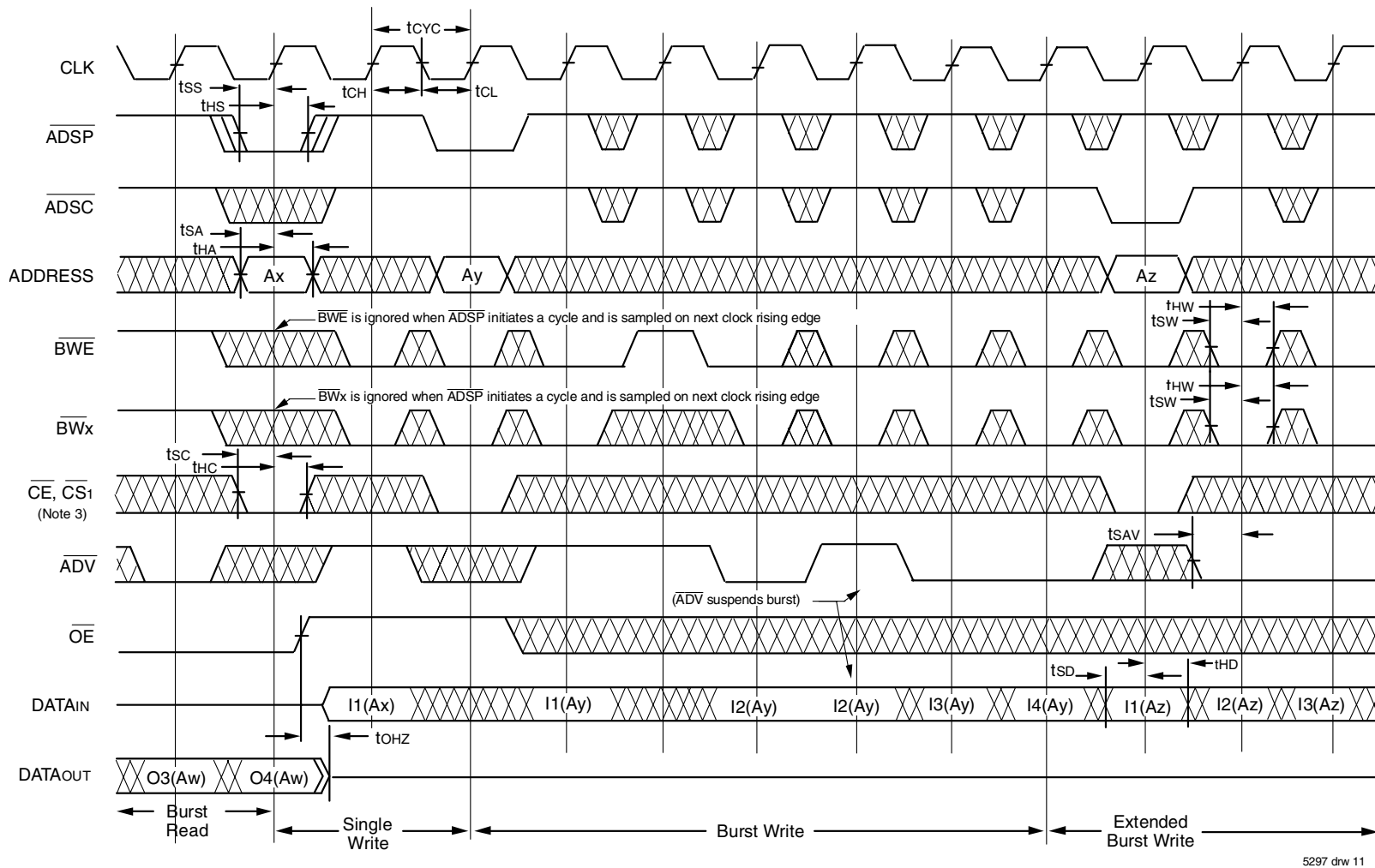

5297 drw 11

NOTES:

1. ZZ input is LOW,  $\overline{GW}$  is HIGH and  $\overline{LB0}$  is Don't Care for this cycle.
2. O4 (Aw) represents the final output data in the burst sequence of the base address Aw. I1 (Ax) represents the first input from the external address Ax. I1 (Ay) represents the first input from the external address Ay; I2 (Ay) represent the next input data in the burst sequence of the base address Ay, etc. where A0 and A1 are advancing for the four word burst in the sequence defined by the state of the  $\overline{LB0}$  input. In the case of input I2 (Ay) this data is valid for two cycles because  $\overline{ADV}$  is high and has suspended the burst.
3. CS0 timing transitions are identical but inverted to the  $\overline{CE}$  and  $\overline{CS1}$  signals. For example, when  $\overline{CE}$  and  $\overline{CS1}$  are LOW on this waveform, CS0 is HIGH.

Timing Waveform of Sleep (ZZ) and Power-Down Modes (1,2,3)

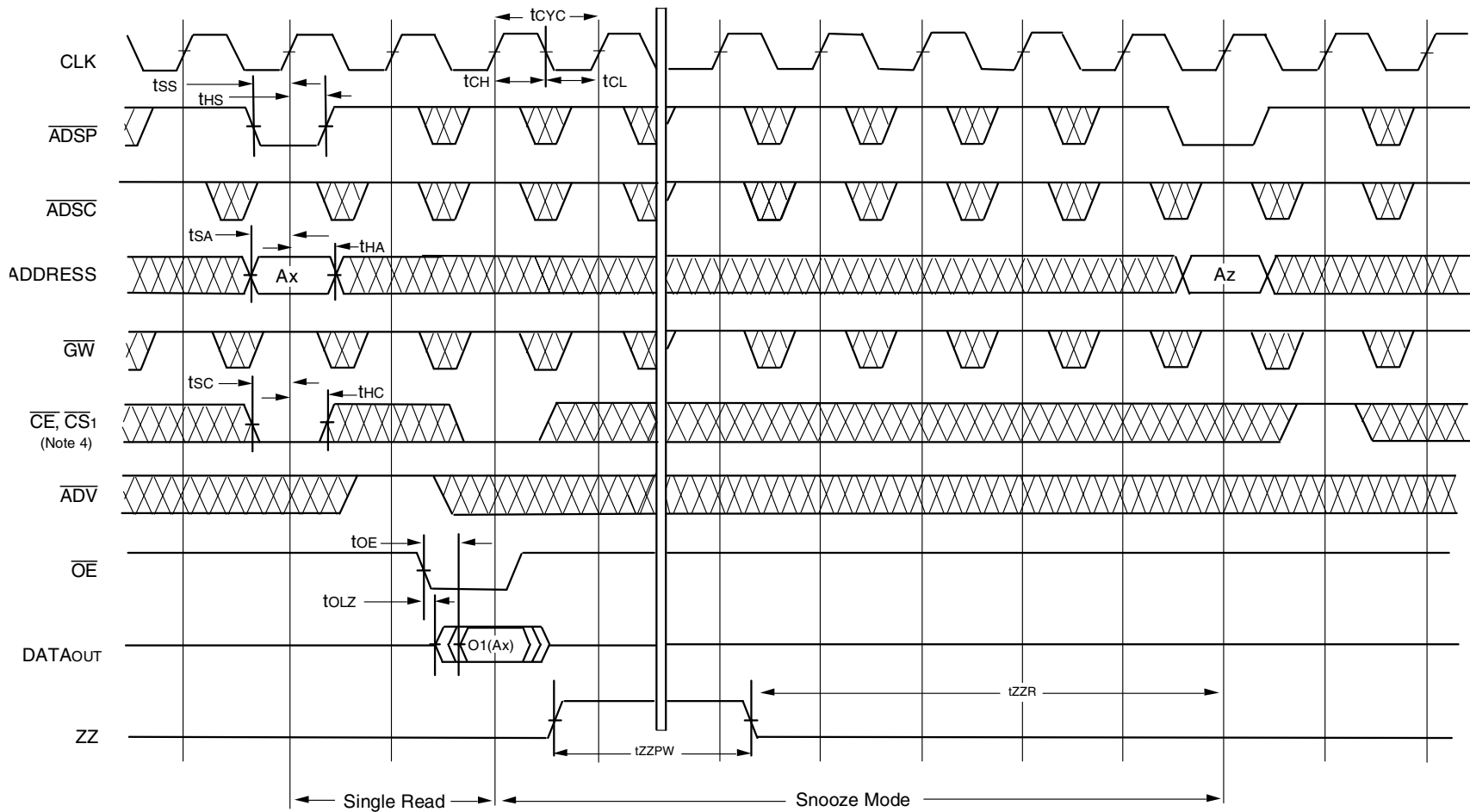

5297 drw 12

NOTES:

1. Device must power up in deselected Mode.
2. LBO is Don't Care for this cycle.
3. It is not necessary to retain the state of the input registers throughout the Power-down cycle.
4. CS0 timing transitions are identical but inverted to the CE and CS1 signals. For example, when CE and CS1 are LOW on this waveform, CS0 is HIGH.

## Non-Burst Read Cycle Timing Waveform

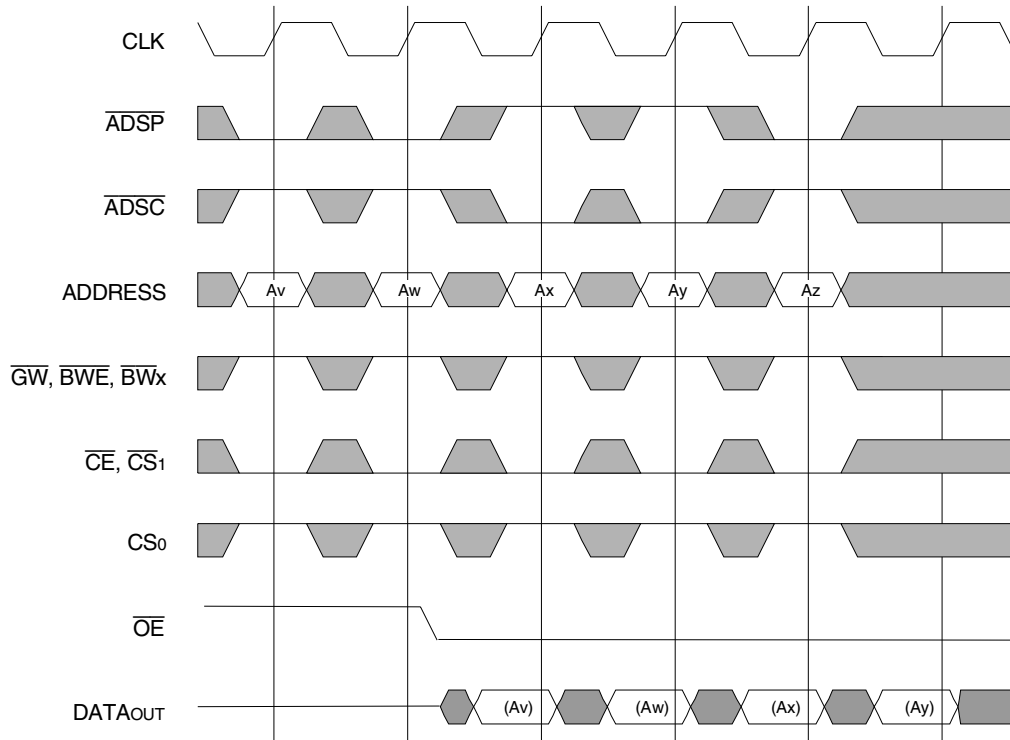

**NOTES:**

1. ZZ input is LOW,  $\overline{ADV}$  is HIGH and  $\overline{LBO}$  is Don't Care for this cycle.
2. (Ax) represents the data for address Ax, etc.
3. For read cycles,  $\overline{ADSP}$  and  $\overline{ADSC}$  function identically and are therefore interchangeable.

5297 drw 14

## Non-Burst Write Cycle Timing Waveform

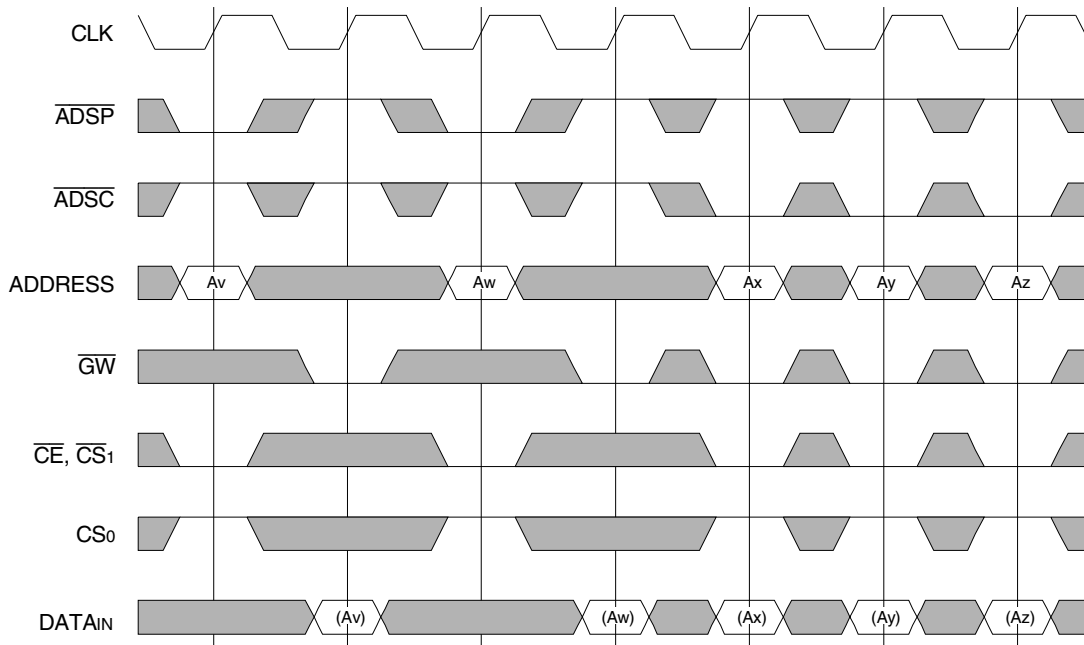

**NOTES:**

1. ZZ input is LOW,  $\overline{ADV}$  and  $\overline{OE}$  are HIGH, and  $\overline{LBO}$  is Don't Care for this cycle.
2. (Ax) represents the data for address Ax, etc.
3. Although only  $\overline{GW}$  writes are shown, the functionality of  $\overline{BWE}$  and  $\overline{BWx}$  together is the same as  $\overline{GW}$ .
4. For write cycles,  $\overline{ADSP}$  and  $\overline{ADSC}$  have different limitations.

5297 drw 15

## JTAG Interface Specification (SA Version only)

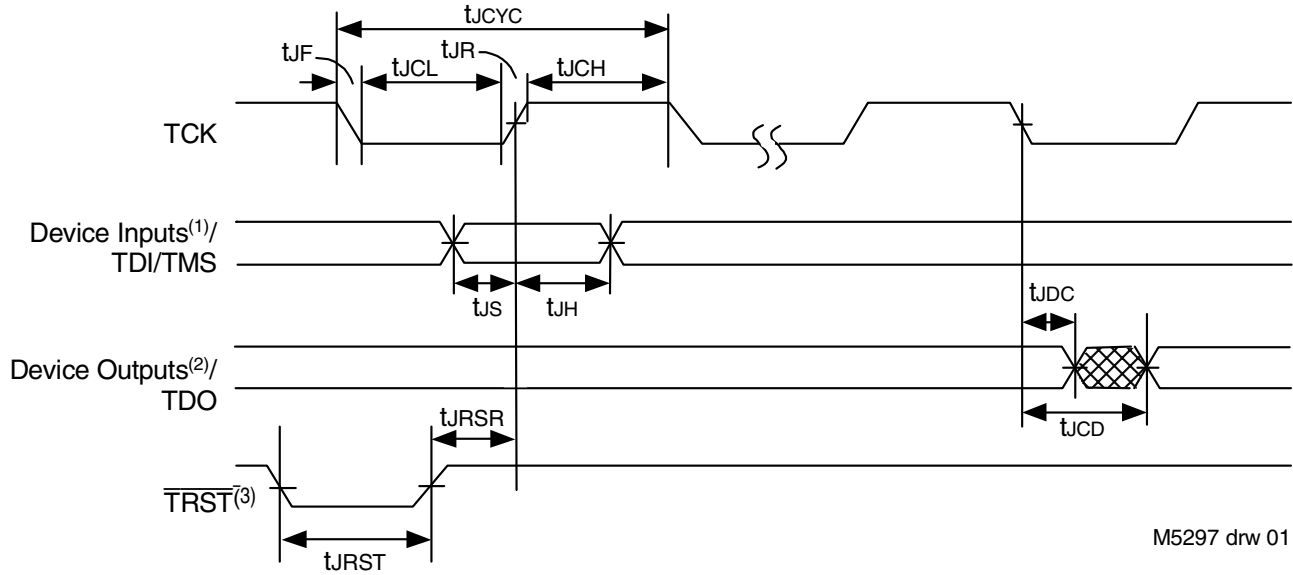

**NOTES:**

1. Device inputs = All device inputs except TDI, TMS and  $\overline{TRST}$ .
2. Device outputs = All device outputs except TDO.
3. During power up,  $\overline{TRST}$  could be driven low or not be used since the JTAG circuit resets automatically.  $\overline{TRST}$  is an optional JTAG reset.

## JTAG AC Electrical Characteristics<sup>(1,2,3,4)</sup>

| Symbol     | Parameter               |      |                  |       |
|------------|-------------------------|------|------------------|-------|
|            |                         | Min. | Max.             | Units |
| $t_{JCYC}$ | JTAG Clock Input Period | 100  | —                | ns    |
| $t_{JCH}$  | JTAG Clock HIGH         | 40   | —                | ns    |
| $t_{JCL}$  | JTAG Clock Low          | 40   | —                | ns    |
| $t_{JR}$   | JTAG Clock Rise Time    | —    | 5 <sup>(1)</sup> | ns    |
| $t_{JF}$   | JTAG Clock Fall Time    | —    | 5 <sup>(1)</sup> | ns    |
| $t_{Jrst}$ | JTAG Reset              | 50   | —                | ns    |
| $t_{JRSR}$ | JTAG Reset Recovery     | 50   | —                | ns    |
| $t_{JCD}$  | JTAG Data Output        | —    | 20               | ns    |
| $t_{JDC}$  | JTAG Data Output Hold   | 0    | —                | ns    |
| $t_{JS}$   | JTAG Setup              | 25   | —                | ns    |
| $t_{JH}$   | JTAG Hold               | 25   | —                | ns    |

15297 tbl 01

**NOTES:**

1. Guaranteed by design.
2. AC Test Load (Fig. 1) on external output signals.
3. Refer to AC Test Conditions stated earlier in this document.
4. JTAG operations occur at one speed (10MHz). The base device may run at any speed specified in this datasheet.

## Scan Register Sizes

| Register Name              | Bit Size |
|----------------------------|----------|
| Instruction (IR)           | 4        |
| Bypass (BYR)               | 1        |
| JTAG Identification (JIDR) | 32       |
| Boundary Scan (BSR)        | Note (1) |

15297 tbl 03

**NOTE:**

1. The Boundary Scan Descriptive Language (BSDL) file for this device is available by contacting your local IDT sales representative.

## JTAG Identification Register Definitions (SA Version only)

| Instruction Field                 | Value        | Description  |
|-----------------------------------|--------------|--|
| Revision Number (31:28)           | 0x2          | Reserved for version number.                                     |
| IDT Device ID (27:12)             | 0x23D, 0x23F | Defines IDT part number 71V25761SA and 71V25781SA, respectively. |
| IDT JEDEC ID (11:1)               | 0x33         | Allows unique identification of device vendor as IDT.            |
| ID Register Indicator Bit (Bit 0) | 1            | Indicates the presence of an ID register.                        |

15297 tbl 02

## Available JTAG Instructions

| Instruction    | Description   | OPCODE |
|----------------|---|--------|
| EXTEST         | Forces contents of the boundary scan cells onto the device outputs <sup>(1)</sup> . Places the boundary scan register (BSR) between TDI and TDO.  | 0000   |
| SAMPLE/PRELOAD | Places the boundary scan register (BSR) between TDI and TDO. SAMPLE allows data from device inputs <sup>(2)</sup> and outputs <sup>(1)</sup> to be captured in the boundary scan cells and shifted serially through TDO. PRELOAD allows data to be input serially into the boundary scan cells via the TDI. | 0001   |
| DEVICE_ID      | Loads the JTAG ID register (JIDR) with the vendor ID code and places the register between TDI and TDO.  | 0010   |
| HIGHZ          | Places the bypass register (BYR) between TDI and TDO. Forces all device output drivers to a High-Z state.   | 0011   |
| RESERVED       | Several combinations are reserved. Do not use codes other than those identified for EXTEST, SAMPLE/PRELOAD, DEVICE_ID, HIGHZ, CLAMP, VALIDATE and BYPASS instructions.  | 0100   |
| RESERVED       |   | 0101   |
| RESERVED       |   | 0110   |
| RESERVED       |   | 0111   |
| CLAMP          | Uses BYR. Forces contents of the boundary scan cells onto the device outputs. Places the bypass register (BYR) between TDI and TDO.   | 1000   |
| RESERVED       | Same as above.  | 1001   |
| RESERVED       |   | 1010   |
| RESERVED       |   | 1011   |
| RESERVED       |   | 1100   |
| VALIDATE       | Automatically loaded into the instruction register whenever the TAP controller passes through the CAPTURE-IR state. The lower two bits '01' are mandated by the IEEE std. 1149.1 specification.   | 1101   |
| RESERVED       | Same as above.  | 1110   |
| BYPASS         | The BYPASS instruction is used to truncate the boundary scan register as a single bit in length.  | 1111   |

15297 tbl 04

### NOTES:

1. Device outputs = All device outputs except TDO.
2. Device inputs = All device inputs except TDI, TMS, and  $\overline{\text{TRST}}$ .

## Ordering Information

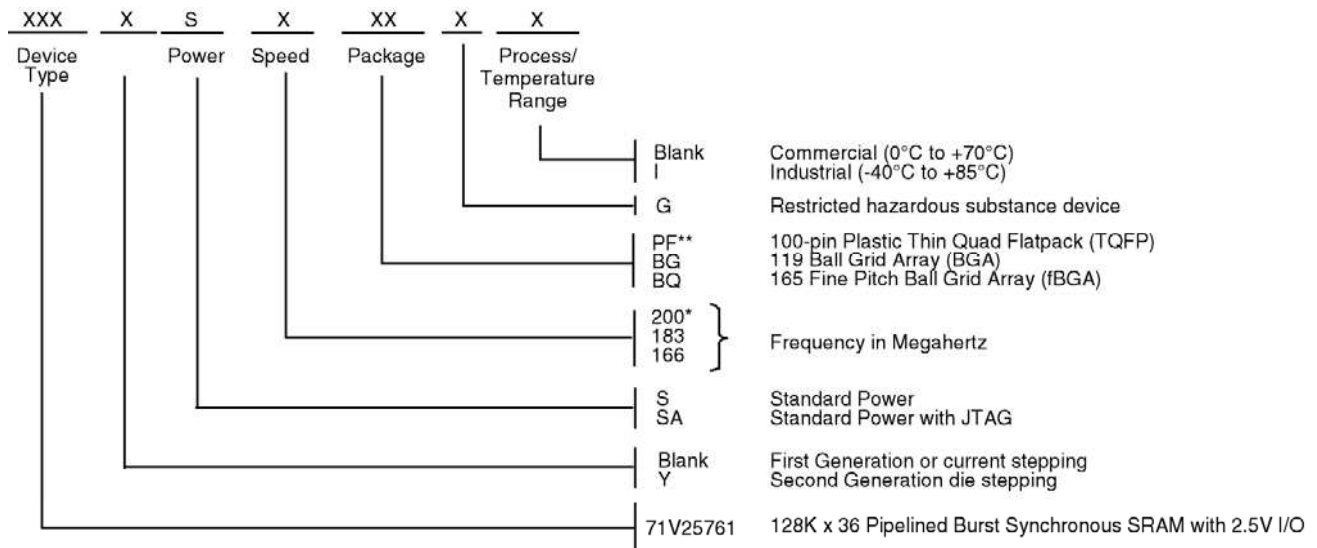

5297 drw 13

\*Available in commercial range only

\*\* JTAG (SA version) is not available with 100-pin TQFP package

## Package Information

100-Pin Thin Quad Plastic Flatpack (TQFP)

119 Ball Grid Array (BGA)

165 Fine Pitch Ball Grid Array (fBGA)

Information available on the IDT website

## Datasheet Document History

|          |                 |  |
|----------|-----------------|--|
| 12/31/99 |                 | Created new datasheet from 71V2576 and 71V2578 datasheets  |
|          | Pg. 1, 4, 8, 19 | Added Industrial Temperature range offerings   |
| 04/04/00 | Pg. 18          | Added 100pin TQFP Package Diagram Outline  |
|          | Pg. 4           | Add capacitance table for BGA package; Add Industrial temperature to table; Insert note to Absolute Max Ratings and Recommended Operating Temperature tables |
| 06/01/00 |                 | Add new package offering, 13 x 15mm 165 fBGA   |
|          | Pg. 20          | Correct BG119 Package Diagram Outline  |
| 07/15/00 | Pg. 7           | Add note reference to BG119 pinout   |
|          | Pg. 8           | Add DNU note to BQ165 pinout   |
|          | Pg. 20          | Update BG119 Package Diagram Outline Dimensions  |
| 10/25/00 |                 | Remove Preliminary from datasheet  |
|          | Pg. 8           | Add reference note to pin N5 in BQ165 pinout, reserved for JTAG, $\overline{\text{TRST}}$  |
| 04/22/03 | Pg.4            | Updated 165 BGA table information from TBD to 7  |
| 06/30/03 | Pg. 1,2,3,5-9   | Updated datasheet with JTAG information  |
|          | Pg. 5-8         | Removed note for NC pins (38,39(PF package); L4, U4 (BG package) H2, N7 (BQ package)) requiring NC or connection to Vss.                                     |
|          | Pg. 19,20       | Added two pages of JTAG Specification, AC Electrical, Definitions and Instructions   |
|          | Pg. 21-23       | Removed old package information from the datasheet   |
|          | Pg. 24          | Updated ordering information with JTAG and Y stepping information. Added information regarding packages available IDT website.                               |
| 03/13/09 | Pg.21           | Removed "IDT" from orderable part number   |
| 05/27/10 | Pg.21           | Added "Restricted hazardous substance device" to the ordering information  |
|          | Pg.1-21         | Removed IDT71V25781S/SA from datasheet.  |



**CORPORATE HEADQUARTERS**  
6024 Silver Creek Valley Road  
San Jose, CA 95138

**for SALES:**  
800-345-7015 or  
408-284-8200  
fax: 408-284-2775  
www.idt.com

**for Tech Support:**  
ipchelp@idt.com  
800-345-7015

The IDT logo is a registered trademark of Integrated Device Technology, Inc.