



HIGH-SPEED 3.3V 32/16K x 16 SYNCHRONOUS DUAL-PORT STATIC RAM

IDT70V9279/69S/L

Features:

- ◆ True Dual-Ported memory cells which allow simultaneous access of the same memory location
- ◆ High-speed clock to data access
 - Commercial: 6.5/7.5/9/12/15ns (max.)
 - Industrial: 7.5ns (max.)
- ◆ Low-power operation
 - IDT70V9279/69S
Active: 429mW (typ.)
Standby: 3.3mW (typ.)
 - IDT70V9279/69L
Active: 429mW (typ.)
Standby: 1.32mW (typ.)
- ◆ Flow-through or Pipelined output mode on either port via the FT/PIPE pin
- ◆ Counter enable and reset features
- ◆ Dual chip enables allow for depth expansion without additional logic
- ◆ Full synchronous operation on both ports
 - 4ns setup to clock and 1ns hold on all control, data, and address inputs
 - Data input, address, and control registers
 - Fast 6.5ns clock to data out in the Pipelined output mode
 - Self-timed write allows fast cycle time
 - 10ns cycle time, 100MHz operation in Pipelined output mode
- ◆ Separate upper-byte and lower-byte controls for multiplexed bus and bus matching compatibility
- ◆ LVTTTL-compatible, single 3.3V (±0.3V) power supply
- ◆ Industrial temperature range (–40°C to +85°C) is available for selected speeds
- ◆ Available in a 128-pin Thin Quad Flatpack (TQFP) package
- ◆ Green parts available, see ordering information

Functional Block Diagram

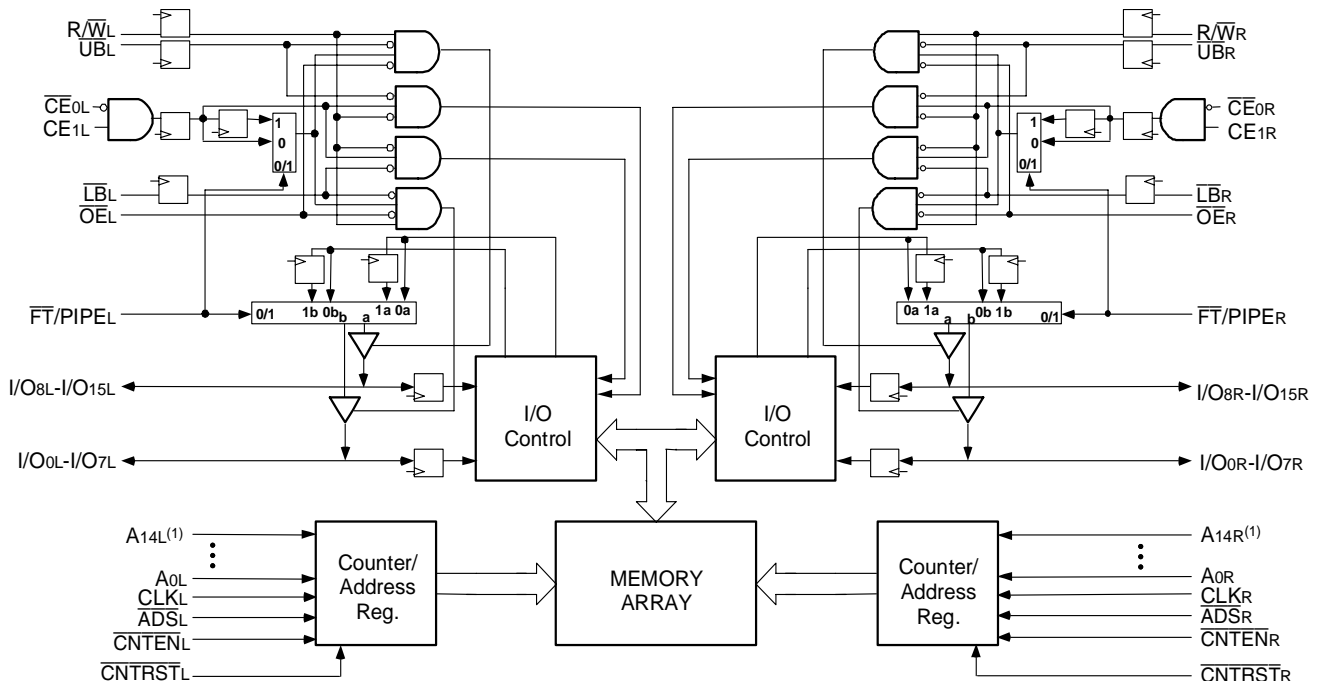

3743 drw 01

NOTE:

1. A14x is a NC for IDT70V9269.

OCTOBER 2008

Description:

The IDT70V9279/69 is a high-speed 32/16K x 16 bit synchronous Dual-Port RAM. The memory array utilizes Dual-Port memory cells to allow simultaneous access of any address from both ports. Registers on control, data, and address inputs provide minimal setup and hold times. The timing latitude provided by this approach allows systems to be designed with very short cycle times.

With an input data register, the IDT70V9279/69 has been optimized for applications having unidirectional or bidirectional data flow in bursts. An automatic power down feature, controlled by \overline{CE}_0 and CE_1 , permits the on-chip circuitry of each port to enter a very low standby power mode. Fabricated using IDT's CMOS high-performance technology, these devices typically operate on only 429mW of power.

Pin Configuration^(2,3,4)

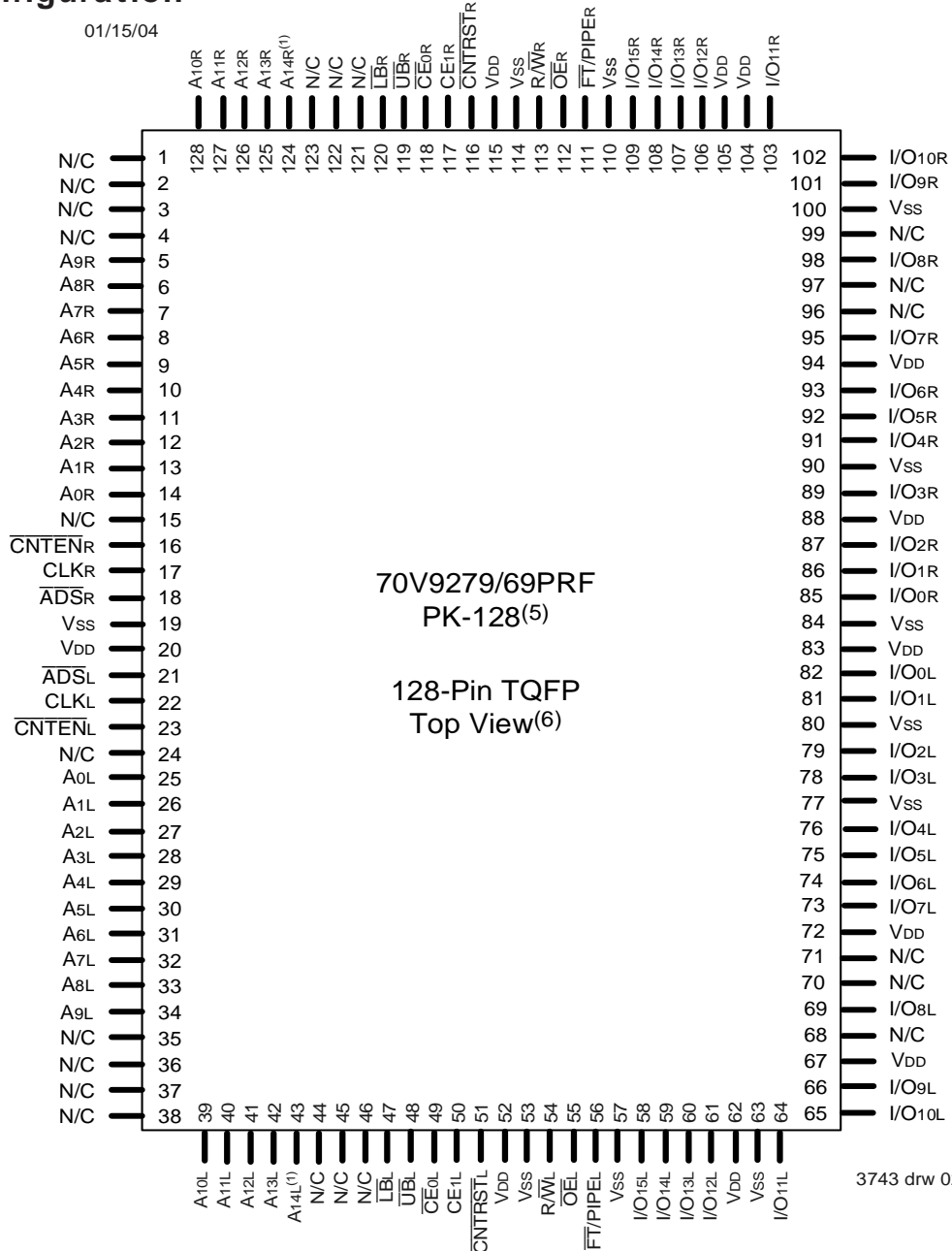

NOTES:

1. A14x is a NC for IDT70V9269.
2. All V_{DD} pins must be connected to power supply.
3. All V_{SS} pins must be connected to ground.
4. Package body is approximately 14mm x 20mm x 1.4mm.
5. This package code is used to reference the package diagram.
6. This text does not indicate orientation of the actual part-marking.

Pin Names

Left Port	Right Port	Names
\overline{CE}_{0L} , CE1L	\overline{CE}_{0R} , CE1R	Chip Enables ⁽³⁾
R/ \overline{WL}	R/ \overline{WR}	Read/Write Enable
\overline{OE}_L	\overline{OE}_R	Output Enable
A0L - A14L ⁽¹⁾	A0R - A14R ⁽¹⁾	Address
I/O0L - I/O15L	I/O0R - I/O15R	Data Input/Output
CLKL	CLKR	Clock
\overline{UB}_L	\overline{UB}_R	Upper Byte Select ⁽²⁾
\overline{LB}_L	\overline{LB}_R	Lower Byte Select ⁽²⁾
\overline{ADS}_L	\overline{ADS}_R	Address Strobe Enable
\overline{CNTEN}_L	\overline{CNTEN}_R	Counter Enable
\overline{CNTRST}_L	\overline{CNTRST}_R	Counter Reset
$\overline{FT/PIPE}_L$	$\overline{FT/PIPE}_R$	Flow-Through / Pipeline
V _{DD}		Power (3.3V)
V _{SS}		Ground (0V)

3743 tbl 01

NOTES:

1. Address A_{14x} is a NC for IDT70V9269.
2. \overline{LB} and \overline{UB} are single buffered regardless of state of $\overline{FT/PIPE}$.
3. \overline{CE}_0 and CE₁ are single buffered when $\overline{FT/PIPE} = V_{IL}$, \overline{CE}_0 and CE₁ are double buffered when $\overline{FT/PIPE} = V_{IH}$, i.e. the signals take two cycles to deselect.

Truth Table I—Read/Write and Enable Control^(1,2,3)

\overline{OE}	CLK	\overline{CE}_0 ⁽⁵⁾	CE ₁ ⁽⁵⁾	\overline{UB} ⁽⁴⁾	\overline{LB} ⁽⁴⁾	R/ \overline{W}	Upper Byte I/O ₈₋₁₅	Lower Byte I/O ₀₋₇	MODE
X	↑	H	X	X	X	X	High-Z	High-Z	Deselected—Power Down
X	↑	X	L	X	X	X	High-Z	High-Z	Deselected—Power Down
X	↑	L	H	H	H	X	High-Z	High-Z	Both Bytes Deselected
X	↑	L	H	L	H	L	D _{IN}	High-Z	Write to Upper Byte Only
X	↑	L	H	H	L	L	High-Z	D _{ATA_{IN}}	Write to Lower Byte Only
X	↑	L	H	L	L	L	D _{ATA_{IN}}	D _{ATA_{IN}}	Write to Both Bytes
L	↑	L	H	L	H	H	D _{ATA_{OUT}}	High-Z	Read Upper Byte Only
L	↑	L	H	H	L	H	High-Z	D _{ATA_{OUT}}	Read Lower Byte Only
L	↑	L	H	L	L	H	D _{ATA_{OUT}}	D _{ATA_{OUT}}	Read Both Bytes
H	↑	L	H	L	L	X	High-Z	High-Z	Outputs Disabled

3743 tbl 02

NOTES:

1. "H" = V_{IH}, "L" = V_{IL}, "X" = Don't Care.
2. \overline{ADS} , \overline{CNTEN} , \overline{CNTRST} = X.
3. \overline{OE} is an asynchronous input signal.
4. \overline{LB} and \overline{UB} are single buffered regardless of state of $\overline{FT/PIPE}$.
5. \overline{CE}_0 and CE₁ are single buffered when $\overline{FT/PIPE} = V_{IL}$. \overline{CE}_0 and CE₁ are double buffered when $\overline{FT/PIPE} = V_{IH}$, i.e. the signals take two cycles to deselect.

Truth Table II—Address Counter Control^(1,2,3)

External Address	Previous Internal Address	Internal Address Used	CLK	\overline{ADS}	\overline{CNTEN}	\overline{CNRST}	I/O ⁽³⁾	MODE
An	X	An	↑	L ⁽⁴⁾	X	H	D _{I/O} (n)	External Address Used
X	An	An + 1	↑	H	L ⁽⁵⁾	H	D _{I/O} (n+1)	Counter Enabled—Internal Address generation
X	An + 1	An + 1	↑	H	H	H	D _{I/O} (n+1)	External Address Blocked—Counter disabled (An + 1 reused)
X	X	A0	↑	X	X	L ⁽⁴⁾	D _{I/O} (0)	Counter Reset to Address 0

NOTES:

- "H" = V_{IH}, "L" = V_{IL}, "X" = Don't Care.
- $\overline{CE_0}$, \overline{LB} , \overline{UB} , and \overline{OE} = V_{IL}; CE₁ and R \overline{W} = V_{IH}.
- Outputs configured in Flow-Through Output mode; if outputs are in Pipelined mode the data out will be delayed by one cycle.
- \overline{ADS} and \overline{CNRST} are independent of all other signals including $\overline{CE_0}$, CE₁, \overline{UB} and \overline{LB} .
- The address counter advances if \overline{CNTEN} = V_{IL} on the rising edge of CLK, regardless of all other signals including $\overline{CE_0}$, CE₁, \overline{UB} and \overline{LB} .

3743 tbl 03

Recommended Operating Temperature and Supply Voltage^(1,2)

Grade	Ambient Temperature	GND	V _{DD}
Commercial	0°C to +70°C	0V	3.3V ± 0.3V
Industrial	-40°C to +85°C	0V	3.3V ± 0.3V

NOTES:

- Industrial temperature: for specific speeds, packages and powers contact your sales office.
- This is the parameter T_A. This is the "instant on" case temperature.

3743 tbl 04

Recommended DC Operating Conditions

Symbol	Parameter	Min.	Typ.	Max.	Unit
V _{DD}	Supply Voltage	3.0	3.3	3.6	V
V _{SS}	Ground	0	0	0	V
V _{IH}	Input High Voltage	2.2	—	V _{DD} +0.3V ⁽²⁾	V
V _{IL}	Input Low Voltage	-0.3 ⁽¹⁾	—	0.8	V

NOTES:

- V_{IL} ≥ -1.5V for pulse width less than 10 ns.
- V_{TERM} must not exceed V_{DD} + 0.3V.

3743 tbl 05

Absolute Maximum Ratings⁽¹⁾

Symbol	Rating	Commercial & Industrial	Unit
V _{TERM} ⁽²⁾	Terminal Voltage with Respect to GND	-0.5 to +4.6	V
T _{BIAS} ⁽³⁾	Temperature Under Bias	-55 to +125	°C
T _{STG}	Storage Temperature	-65 to +150	°C
T _{JN}	Junction Temperature	+150	°C
I _{OUT}	DC Output Current	50	mA

NOTES:

- Stresses greater than those listed under ABSOLUTE MAXIMUM RATINGS may cause permanent damage to the device. This is a stress rating only and functional operation of the device at these or any other conditions above those indicated in the operational sections of this specification is not implied. Exposure to absolute maximum rating conditions for extended periods may affect reliability.
- V_{TERM} must not exceed V_{DD} + 0.3V for more than 25% of the cycle time or 10ns maximum, and is limited to ≤ 20mA for the period of V_{TERM} ≥ V_{DD} + 0.3V.
- Ambient Temperature Under DC Bias. No AC Conditions. Chip Deselected.

3743 tbl 06

Capacitance⁽¹⁾(T_A = +25°C, f = 1.0MHz)

Symbol	Parameter	Conditions	Max.	Unit
C _{IN}	Input Capacitance	V _{IN} = 0V	9	pF
C _{OUT} ⁽²⁾	Output Capacitance	V _{OUT} = 0V	10	pF

NOTES:

- These parameters are determined by device characterization, but are not production tested.
- C_{OUT} also references C_{I/O}.

3743 tbl 07

DC Electrical Characteristics Over the Operating Temperature and Supply Voltage Range ($V_{DD} = 3.3V \pm 0.3V$)

Symbol	Parameter	Test Conditions	70V9279/69S		70V9279/69L		Unit
			Min.	Max.	Min.	Max.	
II _L	Input Leakage Current ⁽¹⁾	$V_{DD} = 3.6V, V_{IN} = 0V \text{ to } V_{DD}$	—	10	—	5	μA
II _O	Output Leakage Current	$\overline{CE}0 = V_{IH} \text{ or } CE1 = V_{IL}, V_{OUT} = 0V \text{ to } V_{DD}$	—	10	—	5	μA
V _{OL}	Output Low Voltage	I _{OL} = +4mA	—	0.4	—	0.4	V
V _{OH}	Output High Voltage	I _{OH} = -4mA	2.4	—	2.4	—	V

3743 tbl 08

NOTE:

- At $V_{DD} \leq 2.0V$ input leakages are undefined.

DC Electrical Characteristics Over the Operating Temperature Supply Voltage Range^(3,6) ($V_{DD} = 3.3V \pm 0.3V$)

Symbol	Parameter	Test Condition	Version	70V9279/69X6 Com'l Only		70V9279/69X7 Com'l & Ind		70V9279/69X9 Com'l Only		Unit	
				Typ. ⁽⁴⁾	Max.	Typ. ⁽⁴⁾	Max.	Typ. ⁽⁴⁾	Max.		
I _{DD}	Dynamic Operating Current (Both Ports Active)	$\overline{CE}L \text{ and } \overline{CE}R = V_{IL},$ Outputs Disabled, $f = f_{MAX}^{(1)}$	COM'L	S	220	395	200	335	180	260	mA
				L	220	350	200	290	180	225	
I _{SB1}	Standby Current (Both Ports - TTL Level Inputs)	$\overline{CE}L = \overline{CE}R = V_{IH}$ $f = f_{MAX}^{(1)}$	COM'L	S	70	145	60	115	50	75	mA
				L	70	130	60	100	50	65	
I _{SB2}	Standby Current (One Port - TTL Level Inputs)	$\overline{CE}^*A = V_{IL} \text{ and } \overline{CE}^*B = V_{IH}^{(5)}$ Active Port Outputs Disabled, $f = f_{MAX}^{(1)}$	COM'L	S	150	280	130	240	110	170	mA
				L	150	250	130	210	110	150	
I _{SB3}	Full Standby Current (Both Ports - CMOS Level Inputs)	Both Ports $\overline{CE}L$ and $\overline{CE}R \geq V_{DD} - 0.2V,$ $V_{IN} \geq V_{DD} - 0.2V$ or $V_{IN} \leq 0.2V, f = 0^{(2)}$	COM'L	S	1.0	5	1.0	5	1.0	5	mA
				L	0.4	3	0.4	3	0.4	3	
I _{SB4}	Full Standby Current (One Port - CMOS Level Inputs)	$\overline{CE}^*A \leq 0.2V$ and $\overline{CE}^*B \geq V_{DD} - 0.2V^{(5)}$ $V_{IN} \geq V_{DD} - 0.2V$ or $V_{IN} \leq 0.2V, \text{ Active Port,}$ Outputs Disabled, $f = f_{MAX}^{(1)}$	COM'L	S	140	270	120	230	100	160	mA
				L	140	240	120	200	100	140	
			IND	S	—	—	130	265	—	—	
				L	—	—	130	240	—	—	

3743 tbl 09a

NOTES:

- At $f = f_{MAX}$, address and control lines (except Output Enable) are cycling at the maximum frequency clock cycle of $1/f_{cyc}$, using "AC TEST CONDITIONS" at input levels of V_{SS} to $3V$.
- $f = 0$ means no address, clock, or control lines change. Applies only to input at CMOS level standby.
- Port "A" may be either left or right port. Port "B" is the opposite from port "A".
- $V_{DD} = 3.3V, T_A = 25^\circ C$ for Typ, and are not production tested. I_{DD DC}($f=0$) = 90mA (Typ).
- $\overline{CE}X = V_{IL}$ means $\overline{CE}0X = V_{IL}$ and $CE1X = V_{IH}$
 $\overline{CE}X = V_{IH}$ means $\overline{CE}0X = V_{IH}$ or $CE1X = V_{IL}$
 $\overline{CE}X \leq 0.2V$ means $\overline{CE}0X \leq 0.2V$ and $CE1X \geq V_{DD} - 0.2V$
 $\overline{CE}X \geq V_{DD} - 0.2V$ means $\overline{CE}0X \geq V_{DD} - 0.2V$ or $CE1X \leq 0.2V$
 'X' represents "L" for left port or "R" for right port.
- 'X' in part numbers indicate power rating (S or L).

DC Electrical Characteristics Over the Operating Temperature Supply Voltage Range^(3,6) ($V_{DD} = 3.3V \pm 0.3V$)(Cont'd)

Symbol	Parameter	Test Condition	Version	70V9279/69X12 Com'l Only		70V9279/69X15 Com'l Only		Unit	
				Typ. ⁽⁴⁾	Max.	Typ. ⁽⁴⁾	Max.		
IDD	Dynamic Operating Current (Both Ports Active)	\overline{CE}_L and $\overline{CE}_R = V_{IL}$, Outputs Disabled, $f = f_{MAX}^{(1)}$	COM'L	S	150	240	130	220	mA
				L	150	205	130	185	
			IND	S	—	—	—	—	
				L	—	—	—	—	
ISB1	Standby Current (Both Ports - TTL Level Inputs)	$\overline{CE}_L = \overline{CE}_R = V_{IH}$ $f = f_{MAX}^{(1)}$	COM'L	S	40	65	30	55	mA
				L	40	50	30	35	
			IND	S	—	—	—	—	
				L	—	—	—	—	
ISB2	Standby Current (One Port - TTL Level Inputs)	$\overline{CE}^*A^* = V_{IL}$ and $\overline{CE}^*B^* = V_{IH}^{(5)}$ Active Port Outputs Disabled, $f = f_{MAX}^{(1)}$	COM'L	S	100	160	90	150	mA
				L	100	140	90	130	
			IND	S	—	—	—	—	
				L	—	—	—	—	
ISB3	Full Standby Current (Both Ports - CMOS Level Inputs)	Both Ports \overline{CE}_L and $\overline{CE}_R \geq V_{DD} - 0.2V$, $V_{IN} \geq V_{DD} - 0.2V$ or $V_{IN} \leq 0.2V$, $f = 0^{(2)}$	COM'L	S	1.0	5	1.0	5	mA
				L	0.4	3	0.4	3	
			IND	S	—	—	—	—	
				L	—	—	—	—	
ISB4	Full Standby Current (One Port - CMOS Level Inputs)	$\overline{CE}^*A^* \leq 0.2V$ and $\overline{CE}^*B^* \geq V_{DD} - 0.2V^{(6)}$ $V_{IN} \geq V_{DD} - 0.2V$ or $V_{IN} \leq 0.2V$, Active Port, Outputs Disabled, $f = f_{MAX}^{(1)}$	COM'L	S	90	150	80	140	mA
				L	90	130	80	120	
			IND	S	—	—	—	—	
				L	—	—	—	—	

3743 tbl 09b

NOTES:

- At $f = f_{MAX}$, address and control lines (except Output Enable) are cycling at the maximum frequency clock cycle of $1/t_{cvc}$, using "AC TEST CONDITIONS" at input levels of V_{SS} to $3V$.
- $f = 0$ means no address, clock, or control lines change. Applies only to input at CMOS level standby.
- Port "A" may be either left or right port. Port "B" is the opposite from port "A".
- $V_{DD} = 3.3V$, $T_A = 25^\circ C$ for Typ, and are not production tested. $I_{DD\ dc}(f=0) = 90mA$ (Typ).
- $\overline{CE}_X = V_{IL}$ means $\overline{CE}_{0X} = V_{IL}$ and $CE_{1X} = V_{IH}$
 $\overline{CE}_X = V_{IH}$ means $\overline{CE}_{0X} = V_{IH}$ or $CE_{1X} = V_{IL}$
 $\overline{CE}_X \leq 0.2V$ means $\overline{CE}_{0X} \leq 0.2V$ and $CE_{1X} \geq V_{DD} - 0.2V$
 $\overline{CE}_X \geq V_{DD} - 0.2V$ means $\overline{CE}_{0X} \geq V_{DD} - 0.2V$ or $CE_{1X} \leq 0.2V$
 'X' represents "L" for left port or "R" for right port.
- 'X' in part numbers indicate power rating (S or L).

AC Test Conditions

Input Pulse Levels	GND to 3.0V
Input Rise/Fall Times	3ns
Input Timing Reference Levels	1.5V
Output Reference Levels	1.5V
Output Load	Figures 1, 2, and 3

7343 tbl 10

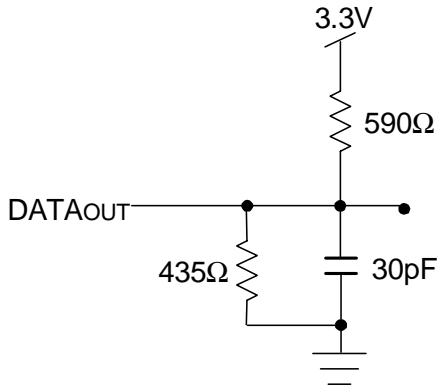

3743 drw 03

Figure 1. AC Output Test load.

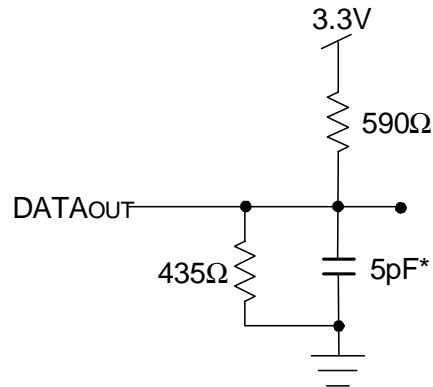

3743 drw 04

Figure 2. Output Test Load
(For tCKLZ, tCKHZ, tOLZ, and tOHZ).
*Including scope and jig.

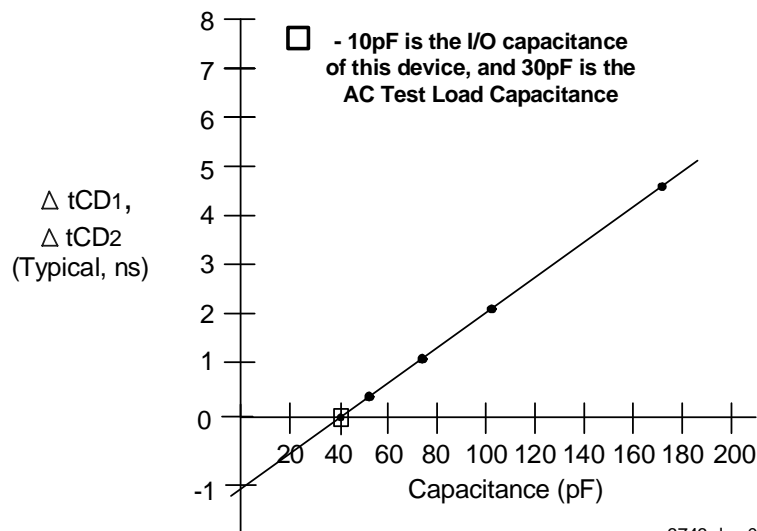

3743 drw 05

Figure 3. Typical Output Derating (Lumped Capacitive Load).

AC Electrical Characteristics Over the Operating Temperature Range (Read and Write Cycle Timing)^(3,4) ($V_{DD} = 3.3V \pm 0.3V$, $T_A = 0^\circ C$ to $+70^\circ C$)

Symbol	Parameter	70V9279/69X6 Com'1 Only		70V9279/69X7 Com'1 & Ind		70V9279/69X9 Com'1 Only		Unit
		Min.	Max.	Min.	Max.	Min.	Max.	
t _{CYC1}	Clock Cycle Time (Flow-Through) ⁽²⁾	19	—	22	—	25	—	ns
t _{CYC2}	Clock Cycle Time (Pipelined) ⁽²⁾	10	—	12	—	15	—	ns
t _{CH1}	Clock High Time (Flow-Through) ⁽²⁾	6.5	—	7.5	—	12	—	ns
t _{CL1}	Clock Low Time (Flow-Through) ⁽²⁾	6.5	—	7.5	—	12	—	ns
t _{CH2}	Clock High Time (Pipelined) ⁽²⁾	4	—	5	—	6	—	ns
t _{CL2}	Clock Low Time (Pipelined) ⁽²⁾	4	—	5	—	6	—	ns
t _r	Clock Rise Time	—	3	—	3	—	3	ns
t _f	Clock Fall Time	—	3	—	3	—	3	ns
t _{SA}	Address Setup Time	3.5	—	4	—	4	—	ns
t _{HA}	Address Hold Time	0	—	0	—	1	—	ns
t _{SC}	Chip Enable Setup Time	3.5	—	4	—	4	—	ns
t _{HC}	Chip Enable Hold Time	0	—	0	—	1	—	ns
t _{SW}	R/W Setup Time	3.5	—	4	—	4	—	ns
t _{HW}	R/W Hold Time	0	—	0	—	1	—	ns
t _{SD}	Input Data Setup Time	3.5	—	4	—	4	—	ns
t _{HD}	Input Data Hold Time	0	—	0	—	1	—	ns
t _{SAD}	\overline{ADS} Setup Time	3.5	—	4	—	4	—	ns
t _{HAD}	\overline{ADS} Hold Time	0	—	0	—	1	—	ns
t _{SCN}	\overline{CNTEN} Setup Time	3.5	—	4	—	4	—	ns
t _{HCN}	\overline{CNTEN} Hold Time	0	—	0	—	1	—	ns
t _{SRST}	\overline{CNRST} Setup Time	3.5	—	4	—	4	—	ns
t _{HRST}	\overline{CNRST} Hold Time	0	—	0	—	1	—	ns
t _{OE}	Output Enable to Data Valid	—	6.5	—	7.5	—	9	ns
t _{OLZ}	Output Enable to Output Low-Z ⁽¹⁾	2	—	2	—	2	—	ns
t _{OHZ}	Output Enable to Output High-Z ⁽¹⁾	1	7	1	7	1	7	ns
t _{CD1}	Clock to Data Valid (Flow-Through) ⁽²⁾	—	15	—	18	—	20	ns
t _{CD2}	Clock to Data Valid (Pipelined) ⁽²⁾	—	6.5	—	7.5	—	9	ns
t _{DC}	Data Output Hold After Clock High	2	—	2	—	2	—	ns
t _{CKHZ}	Clock High to Output High-Z ⁽¹⁾	2	9	2	9	2	9	ns
t _{CKLZ}	Clock High to Output Low-Z ⁽¹⁾	2	—	2	—	2	—	ns
Port-to-Port Delay								
t _{CWDD}	Write Port Clock High to Read Data Delay	—	24	—	28	—	35	ns
t _{CCS}	Clock-to-Clock Setup Time	—	9	—	10	—	15	ns

NOTES:

3743 tbl 11a

- Transition is measured 0mV from Low or High-impedance voltage with the Output Test Load (Figure 2). This parameter is guaranteed by device characterization, but is not production tested.
- The Pipelined output parameters (t_{CYC2}, t_{CD2}) apply to either or both left and right ports when $\overline{FT}/PIPE = V_{IH}$. Flow-through parameters (t_{CYC1}, t_{CD1}) apply when $\overline{FT}/PIPE = V_{IL}$ for that port.
- All input signals are synchronous with respect to the clock except for the asynchronous Output Enable (\overline{OE}) and $\overline{FT}/PIPE$. $\overline{FT}/PIPE$ should be treated as a DC signal, i.e. steady state during operation.
- 'X' in part number indicates power rating (S or L).

AC Electrical Characteristics Over the Operating Temperature Range (Read and Write Cycle Timing)^(3,4) ($V_{DD} = 3.3V \pm 0.3V$, $T_A = 0^\circ C$ to $+70^\circ C$)(Cont'd)

Symbol	Parameter	70V9279/69X12 Com'l Only		70V9279/69X15 Com'l Only		Unit
		Min.	Max.	Min.	Max.	
t _{CYC1}	Clock Cycle Time (Flow-Through) ⁽²⁾	30	—	35	—	ns
t _{CYC2}	Clock Cycle Time (Pipelined) ⁽²⁾	20	—	25	—	ns
t _{CH1}	Clock High Time (Flow-Through) ⁽²⁾	12	—	12	—	ns
t _{CL1}	Clock Low Time (Flow-Through) ⁽²⁾	12	—	12	—	ns
t _{CH2}	Clock High Time (Pipelined) ⁽²⁾	8	—	10	—	ns
t _{CL2}	Clock Low Time (Pipelined) ⁽²⁾	8	—	10	—	ns
t _R	Clock Rise Time	—	3	—	3	ns
t _F	Clock Fall Time	—	3	—	3	ns
t _{SA}	Address Setup Time	4	—	4	—	ns
t _{HA}	Address Hold Time	1	—	1	—	ns
t _{SC}	Chip Enable Setup Time	4	—	4	—	ns
t _{HC}	Chip Enable Hold Time	1	—	1	—	ns
t _{SW}	R/W Setup Time	4	—	4	—	ns
t _{HW}	R/W Hold Time	1	—	1	—	ns
t _{SD}	Input Data Setup Time	4	—	4	—	ns
t _{HD}	Input Data Hold Time	1	—	1	—	ns
t _{SAD}	\overline{ADS} Setup Time	4	—	4	—	ns
t _{HAD}	\overline{ADS} Hold Time	1	—	1	—	ns
t _{SCN}	\overline{CNTEN} Setup Time	4	—	4	—	ns
t _{HCN}	\overline{CNTEN} Hold Time	1	—	1	—	ns
t _{SRST}	\overline{CNRST} Setup Time	4	—	4	—	ns
t _{HRST}	\overline{CNRST} Hold Time	1	—	1	—	ns
t _{OE}	Output Enable to Data Valid	—	12	—	15	ns
t _{OLZ}	Output Enable to Output Low-Z ⁽¹⁾	2	—	2	—	ns
t _{OHZ}	Output Enable to Output High-Z ⁽¹⁾	1	7	1	7	ns
t _{CD1}	Clock to Data Valid (Flow-Through) ⁽²⁾	—	25	—	30	ns
t _{CD2}	Clock to Data Valid (Pipelined) ⁽²⁾	—	12	—	15	ns
t _{DC}	Data Output Hold After Clock High	2	—	2	—	ns
t _{CKHZ}	Clock High to Output High-Z ⁽¹⁾	2	9	2	9	ns
t _{CKLZ}	Clock High to Output Low-Z ⁽¹⁾	2	—	2	—	ns
Port-to-Port Delay						
t _{CWDD}	Write Port Clock High to Read Data Delay	—	40	—	50	ns
t _{CCS}	Clock-to-Clock Setup Time	—	15	—	20	ns

3743 tbl 11b

NOTES:

1. Transition is measured 0mV from Low or High-impedance voltage with the Output Test Load (Figure 2). This parameter is guaranteed by device characterization, but is not production tested.
2. The Pipelined output parameters (t_{CYC2}, t_{CD2}) apply to either or both left and right ports when $\overline{FT}/PIPE = V_{IH}$. Flow-through parameters (t_{CYC1}, t_{CD1}) apply when $\overline{FT}/PIPE = V_{IL}$ for that port.
3. All input signals are synchronous with respect to the clock except for the asynchronous Output Enable (\overline{OE}) and $\overline{FT}/PIPE$. $\overline{FT}/PIPE$ should be treated as a DC signal, i.e. steady state during operation.
4. 'X' in part number indicates power rating (S or L).

Timing Waveform of Read Cycle for Flow-through Output ($\overline{FT}/PIPE "x" = V_{IL}$)(3,7)

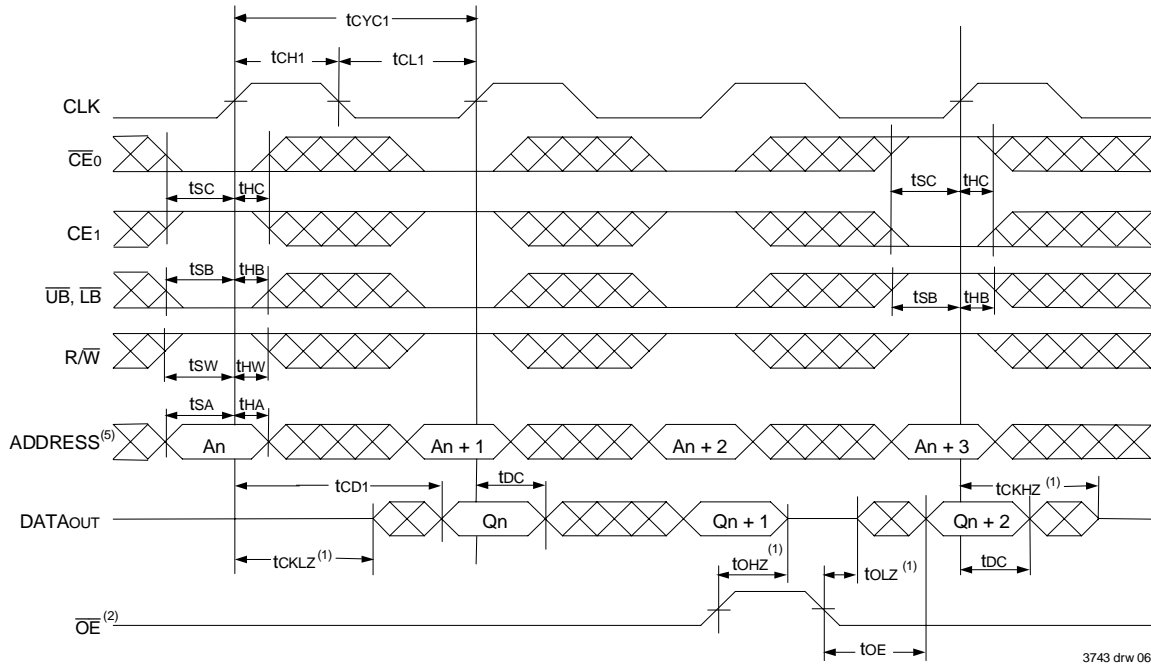

3743 drw 06

Timing Waveform of Read Cycle for Pipelined Output ($\overline{FT}/PIPE "x" = V_{IH}$)(3,7)

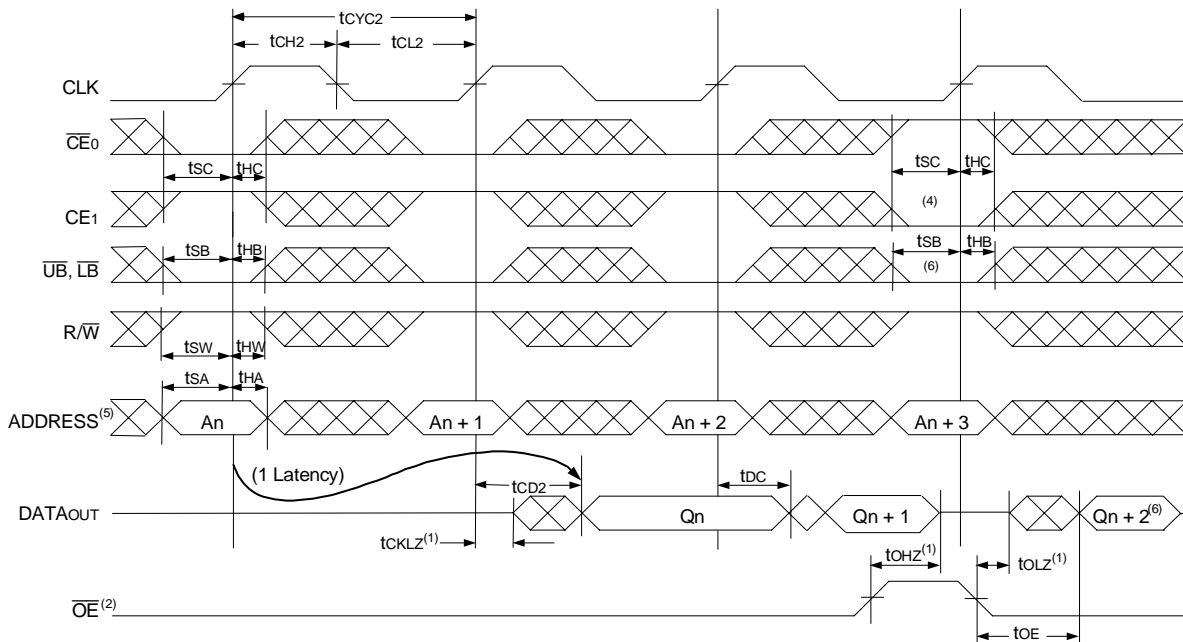

3743 drw 07

NOTES:

1. Transition is measured 0mV from Low or High-impedance voltage with the Output Test Load (Figure 2).
2. \overline{OE} is asynchronously controlled; all other inputs are synchronous to the rising clock edge.
3. $\overline{ADS} = V_{IL}$, \overline{CNTEN} and $\overline{CNRST} = V_{IH}$.
4. The output is disabled (High-Impedance state) by $\overline{CE}_0 = V_{IH}$ or $CE_1 = V_{IL}$ following the next rising edge of the clock. Refer to Truth Table 1.
5. Addresses do not have to be accessed sequentially since $\overline{ADS} = V_{IL}$ constantly loads the address on the rising edge of the CLK; numbers are for reference use only.
6. If \overline{UB} or \overline{LB} was HIGH, then the Upper Byte and/or Lower Byte of DATAout for $Q_n + 2$ would be disabled (High-Impedance state).
7. "x" denotes Left or Right port. The diagram is with respect to that port.

Timing Waveform of a Bank Select Pipelined Read^(1,2)

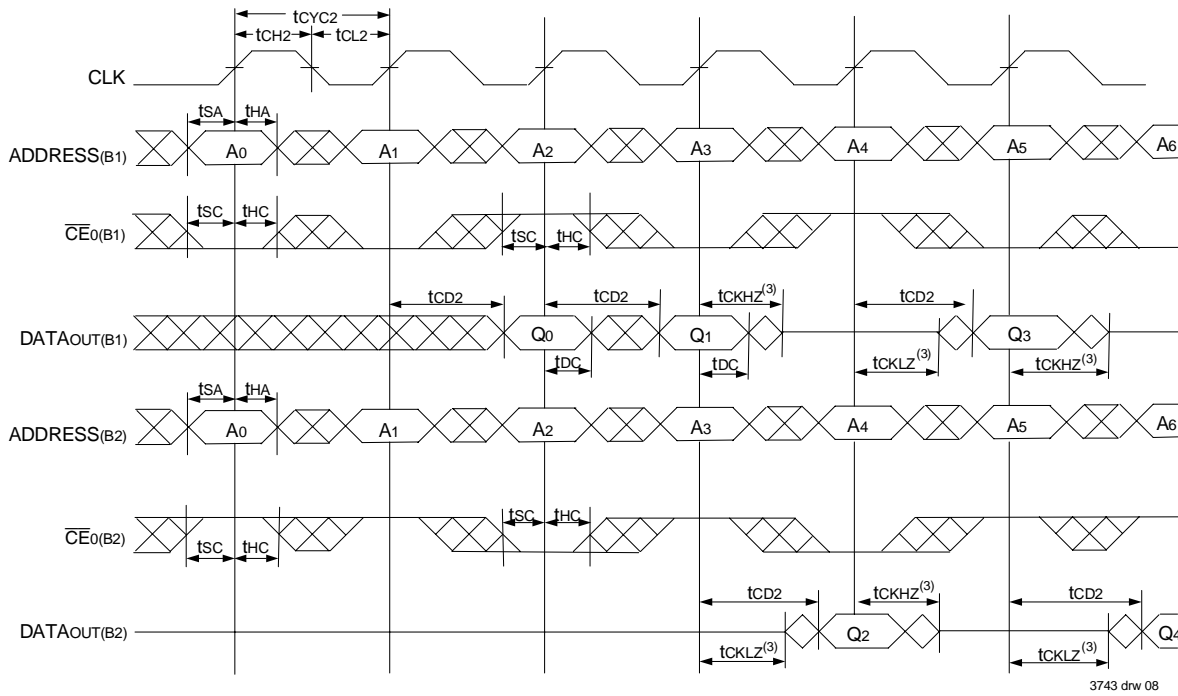

3743 drw 08

Timing Waveform of a Bank Select Flow-Through Read⁽⁶⁾

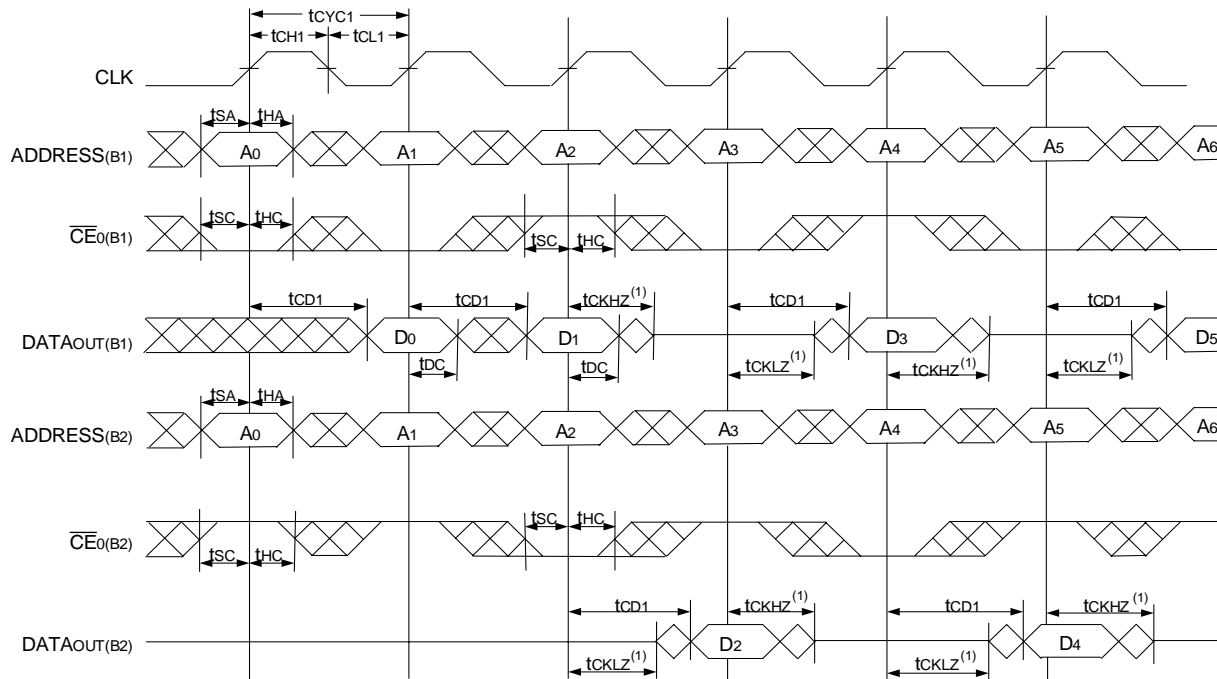

3743 drw 08a

NOTES:

1. B1 Represents Bank #1; B2 Represents Bank #2. Each Bank consists of one IDT70V9279/69 for this waveform, and are setup for depth expansion in this example. ADDRESS(B1) = ADDRESS(B2) in this situation.
2. \overline{UB} , \overline{LB} , \overline{OE} , and $\overline{ADS} = V_{IL}$; $CE_{1(B1)}$, $CE_{1(B2)}$, R/\overline{W} , \overline{CNTEN} , and $\overline{CNTRST} = V_{IH}$.
3. Transition is measured 0mV from Low or High-impedance voltage with the Output Test Load (Figure 2).
4. \overline{CE}_0 , \overline{UB} , \overline{LB} , and $\overline{ADS} = V_{IL}$; CE_1 , \overline{CNTEN} , and $\overline{CNTRST} = V_{IH}$.
5. $\overline{OE} = V_{IL}$ for the Right Port, which is being read from. $\overline{OE} = V_{IH}$ for the Left Port, which is being written to.
6. If $t_{CCS} \leq$ maximum specified, then data from right port READ is not valid until the maximum specified for t_{CWD} . If $t_{CCS} >$ maximum specified, then data from right port READ is not valid until $t_{CCS} + t_{CD1}$. t_{CWD} does not apply in this case.

Timing Waveform with Port-to-Port Flow-Through Read(1,2,3,5)

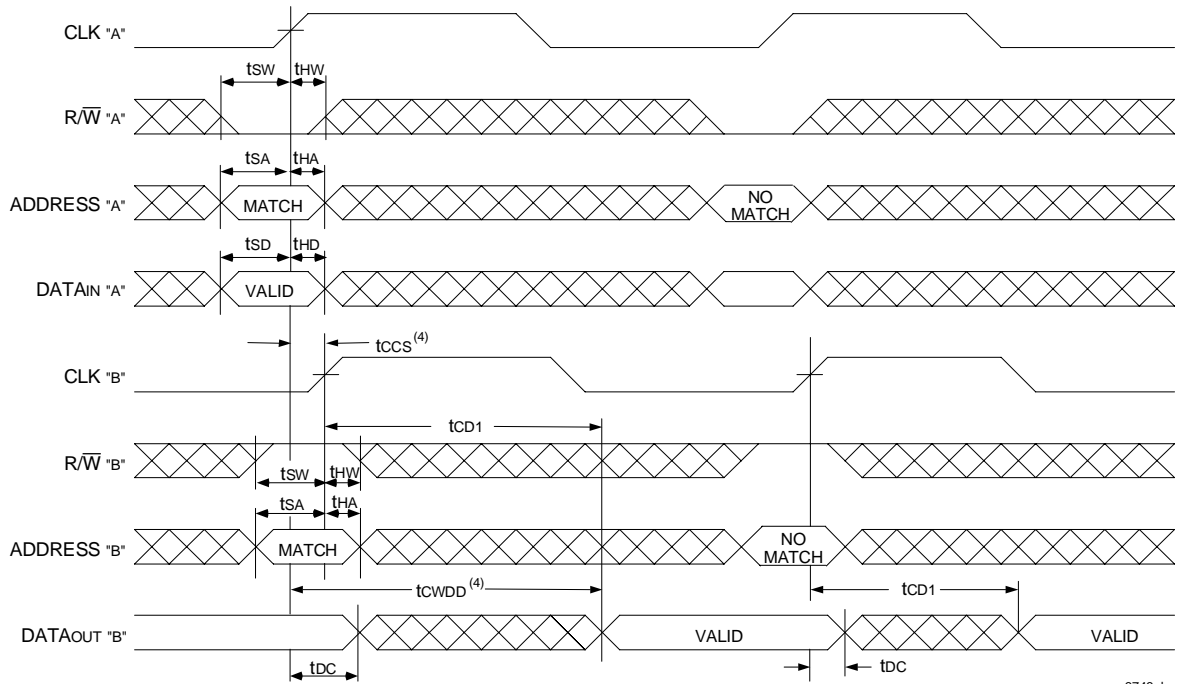

3743 drw 09

NOTES:

1. Transition is measured 0mV from Low or High-impedance voltage with the Output Test Load (Figure 2).
2. \overline{CE}_0 , \overline{UB} , \overline{LB} , and $\overline{ADS} = V_{IL}$; CE_1 , \overline{CNTEN} , and $\overline{CNTRST} = V_{IH}$.
3. $\overline{OE} = V_{IL}$ for the Right Port, which is being read from. $\overline{OE} = V_{IH}$ for the Left Port, which is being written to.
4. If $t_{CCS} \leq$ maximum specified, then data from right port READ is not valid until the maximum specified for t_{CWD} . If $t_{CCS} >$ maximum specified, then data from right port READ is not valid until $t_{CCS} + t_{CD1}$. t_{CWD} does not apply in this case.
5. All timing is the same for both left and right ports. Port "A" may be either left or right port. Port "B" is the opposite of Port "A".

Timing Waveform of Left Port Write to Pipelined Right Port Read(1,2,4)

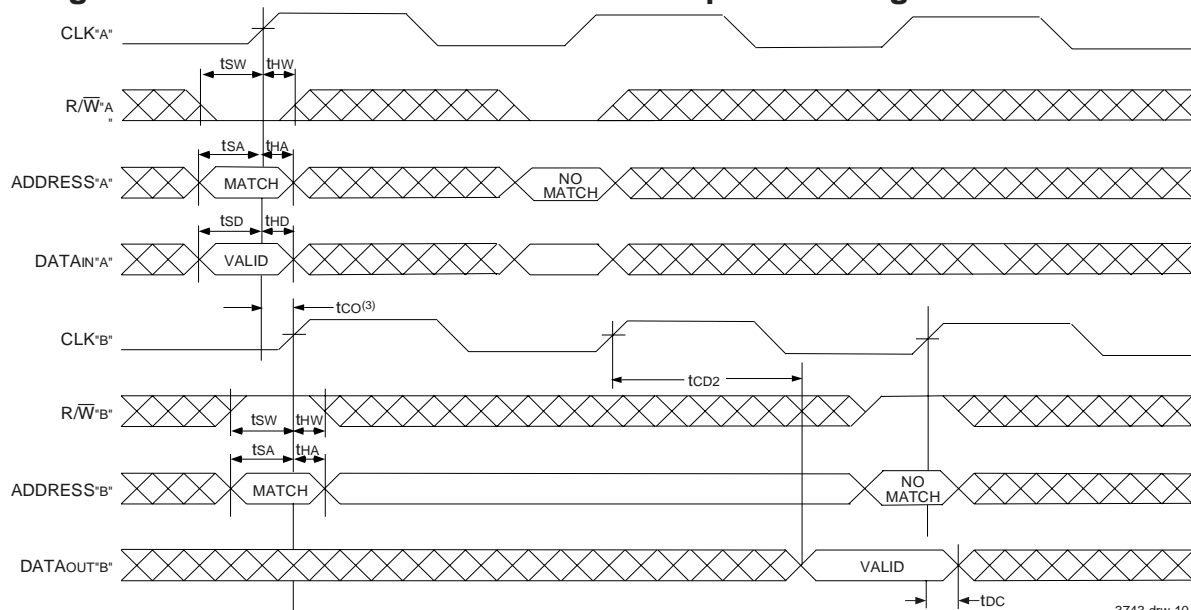

3743 drw 10

NOTES:

1. \overline{CE}_0 , \overline{BE}_n , and $\overline{ADS} = V_{IL}$; CE_1 , \overline{CNTEN} , and $\overline{REPEAT} = V_{IH}$.
2. $\overline{OE} = V_{IL}$ for Port "B", which is being read from. $\overline{OE} = V_{IH}$ for Port "A", which is being written to.
3. If $t_{CO} \leq$ minimum specified, then data from Port "B" read is not valid until following Port "B" clock cycle (ie, time from write to valid read on opposite port will be $t_{CO} + 2 t_{CYC2} + t_{CD2}$). If $t_{CO} >$ minimum, then data from Port "B" read is available on first Port "B" clock cycle (ie, time from write to valid read on opposite port will be $t_{CO} + t_{CYC2} + t_{CD2}$).
4. All timing is the same for Left and Right ports. Port "A" may be either Left or Right port. Port "B" is the opposite of Port "A"

Timing Waveform of Pipelined Read-to-Write-to-Read ($\overline{OE} = V_{IL}$)⁽³⁾

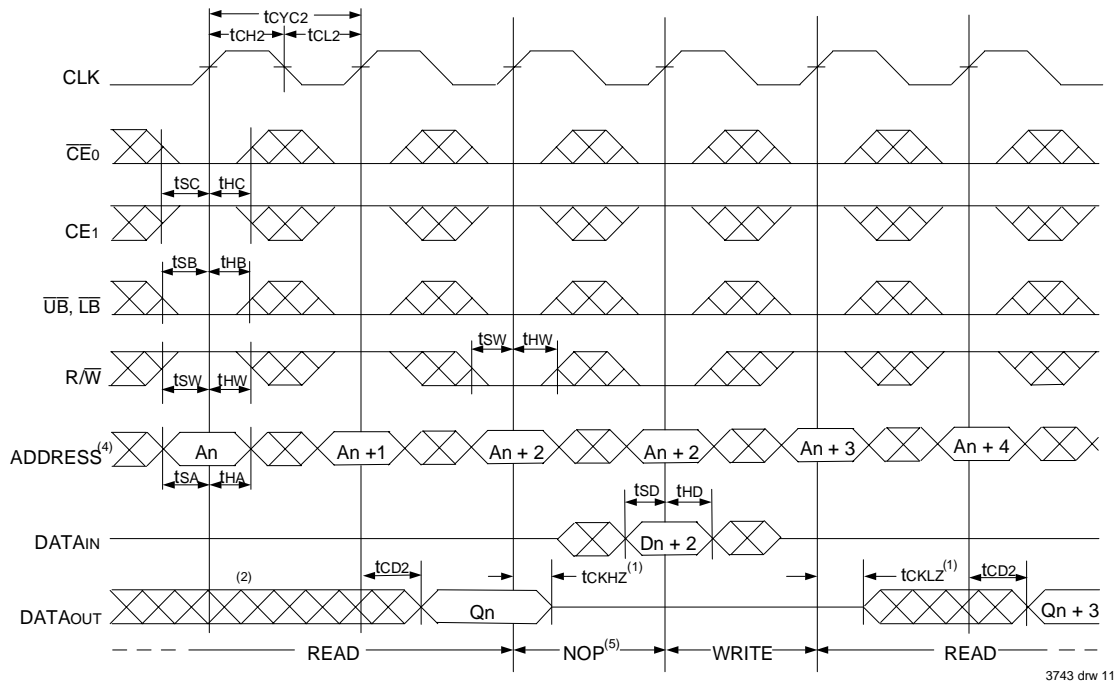

Timing Waveform of Pipelined Read-to-Write-to-Read (\overline{OE} Controlled)⁽³⁾

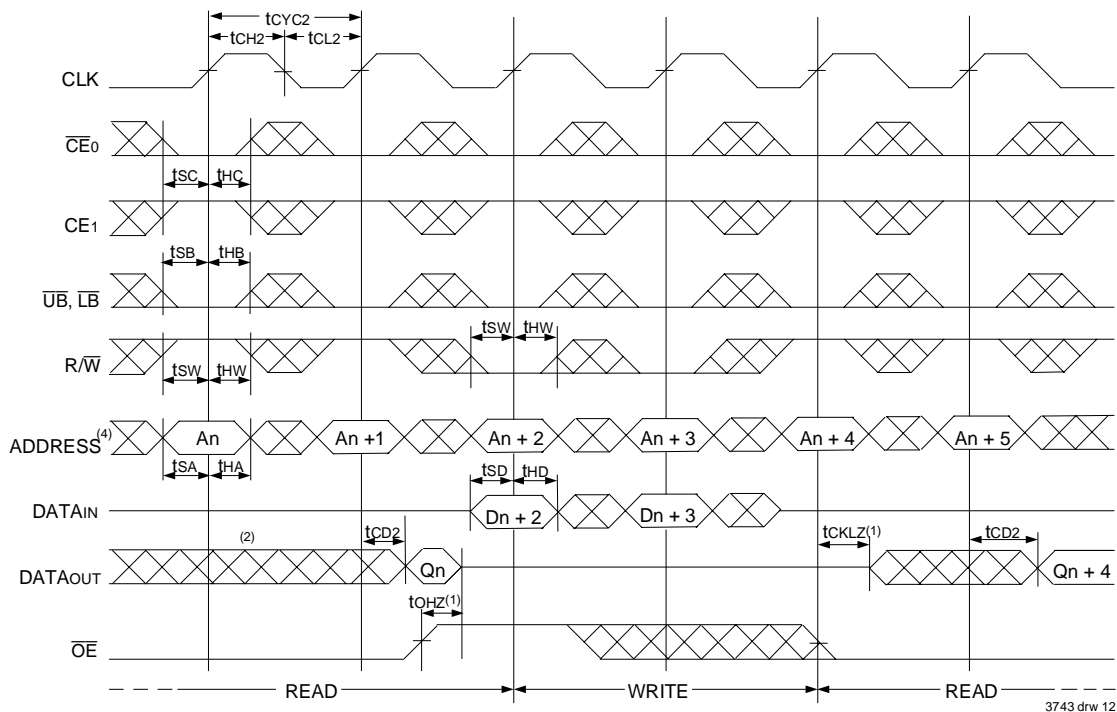

NOTES:

1. Transition is measured 0mV from Low or High-impedance voltage with the Output Test Load (Figure 2).
2. Output state (High, Low, or High-impedance) is determined by the previous cycle control signals.
3. \overline{CE}_0 , \overline{UB} , \overline{LB} , and $\overline{ADS} = V_{IL}$; \overline{CE}_1 , \overline{CNTEN} , and $\overline{CNTRST} = V_{IH}$.
4. Addresses do not have to be accessed sequentially since $\overline{ADS} = V_{IL}$ constantly loads the address on the rising edge of the CLK; numbers are for reference use only.
5. "NOP" is "No Operation." Data in memory at the selected address may be corrupted and should be re-written to guarantee data integrity.

Timing Waveform of Flow-Through Read-to-Write-to-Read ($\overline{OE} = V_{IL}$)⁽³⁾

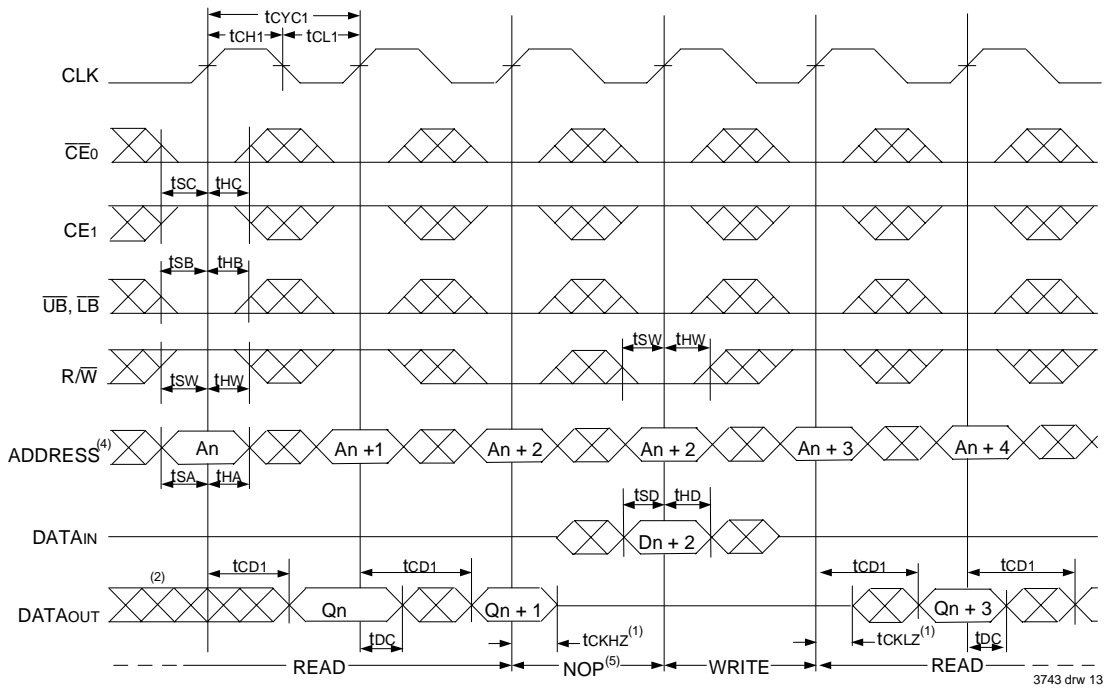

Timing Waveform of Flow-Through Read-to-Write-to-Read (\overline{OE} Controlled)⁽³⁾

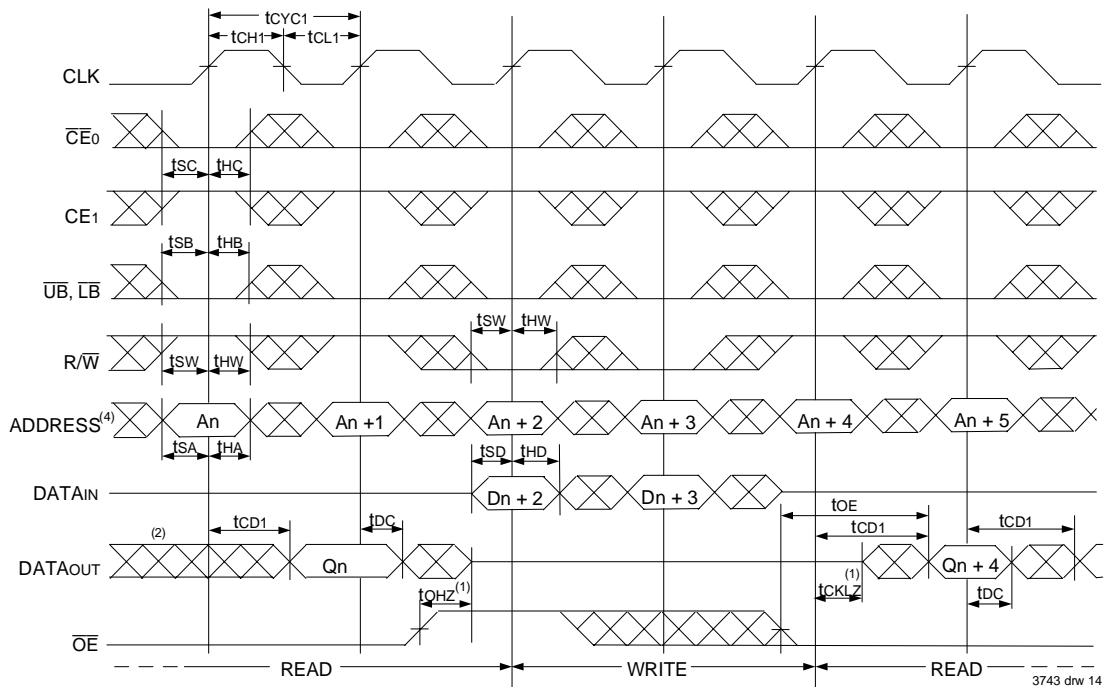

NOTES:

1. Transition is measured 0mV from Low or High-impedance voltage with the Output Test Load (Figure 2).
2. Output state (High, Low, or High-impedance) is determined by the previous cycle control signals.
3. $\overline{CE0}$, \overline{UB} , \overline{LB} , and $\overline{ADS} = V_{IL}$; $\overline{CE1}$, \overline{CNTEN} , and $\overline{CNTNST} = V_{IH}$.
4. Addresses do not have to be accessed sequentially since $\overline{ADS} = V_{IL}$ constantly loads the address on the rising edge of the CLK; numbers are for reference use only.
5. "NOP" is "No Operation." Data in memory at the selected address may be corrupted and should be re-written to guarantee data integrity.

Timing Waveform of Pipelined Read with Address Counter Advance ⁽¹⁾

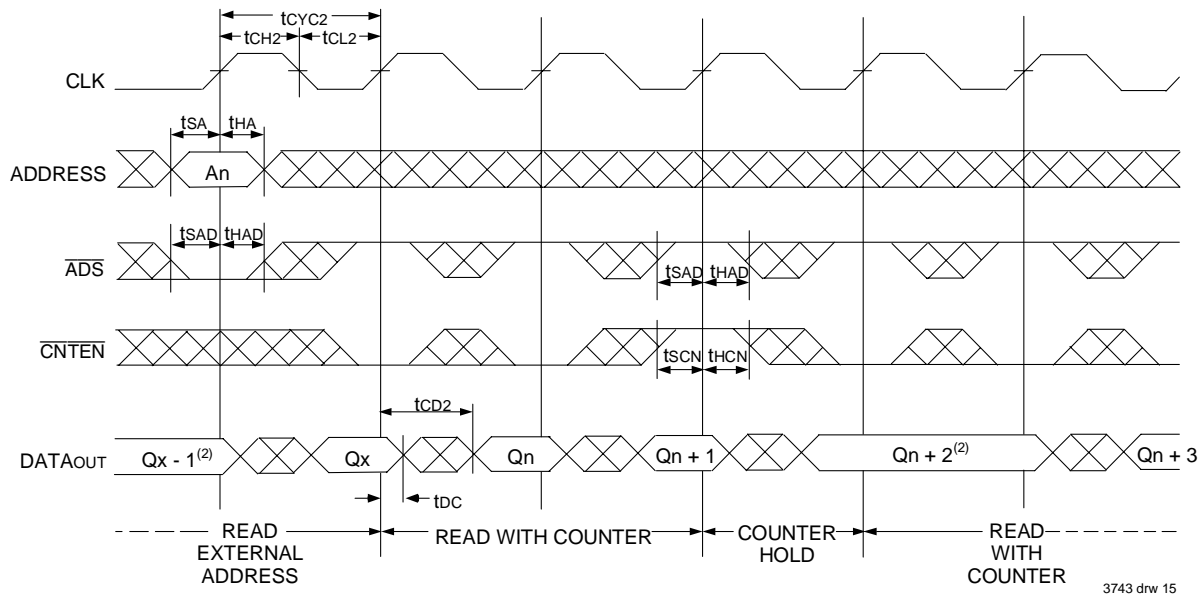

Timing Waveform of Flow-Through Read with Address Counter Advance ⁽¹⁾

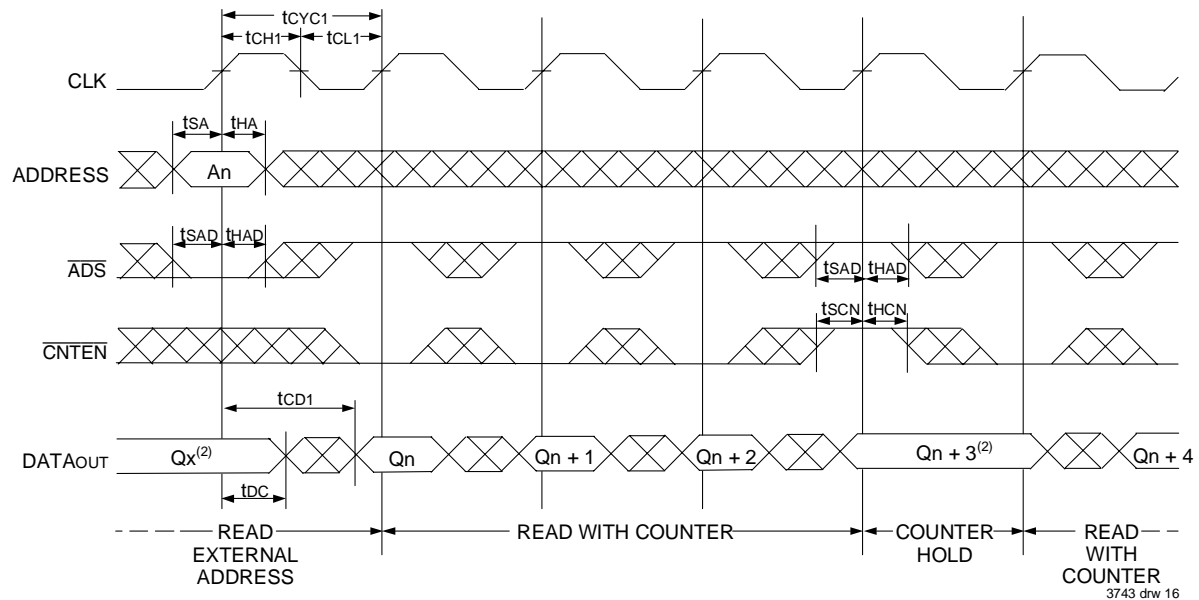

NOTES:

1. \overline{CE}_0 , \overline{OE} , \overline{UB} , and $\overline{LB} = V_{IL}$; CE_1 , $R\overline{W}$, and $\overline{CNTRST} = V_{IH}$.

2. If there is no address change via $ADS = V_{IL}$ (loading a new address) or $\overline{CNTEN} = V_{IL}$ (advancing the address), i.e. $\overline{ADS} = V_{IH}$ and $\overline{CNTEN} = V_{IH}$, then the data output remains constant for subsequent clocks.

Timing Waveform of Write with Address Counter Advance (Flow-Through or Pipelined Outputs)⁽¹⁾

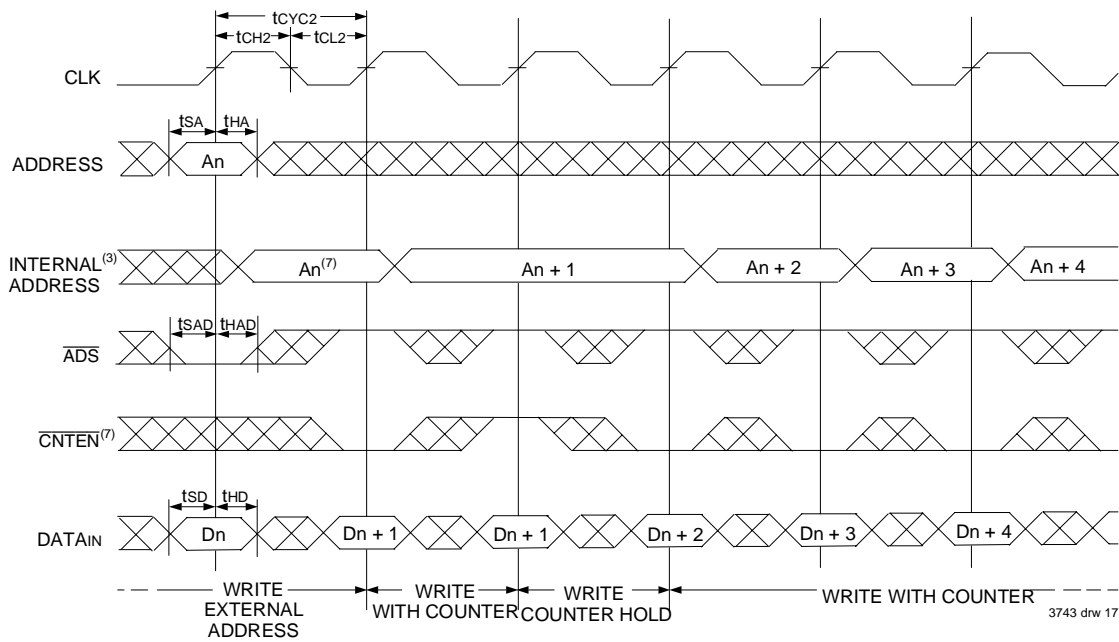

Timing Waveform of Counter Reset (Pipelined Outputs)⁽²⁾

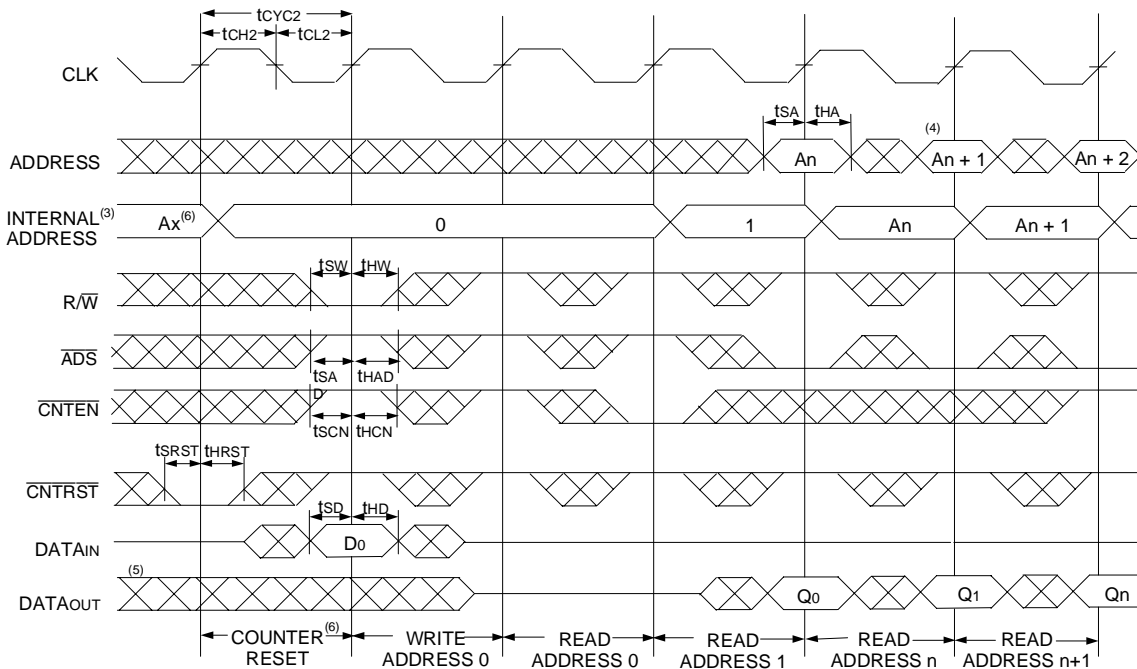

NOTES:

- \overline{CE}_0 , \overline{UB} , \overline{LB} , and $R/\overline{W} = V_{IL}$; CE_1 and $\overline{CNTRST} = V_{IH}$.
- \overline{CE}_0 , \overline{UB} , $\overline{LB} = V_{IL}$; $CE_1 = V_{IH}$.
- The "Internal Address" is equal to the "External Address" when $\overline{ADS} = V_{IL}$ and equals the counter output when $\overline{ADS} = V_{IH}$.
- Addresses do not have to be accessed sequentially since $\overline{ADS} = V_{IL}$ constantly loads the address on the rising edge of the CLK; numbers are for reference use only.
- Output state (High, Low, or High-impedance) is determined by the previous cycle control signals.
- No dead cycle exists during counter reset. A READ or WRITE cycle may be coincidental with the counter reset cycle. ADDR₀ will be accessed. Extra cycles are shown here simply for clarification.
- $\overline{CNTEN} = V_{IL}$ advances Internal Address from 'An' to 'An + 1'. The transition shown indicates the time required for the counter to advance. The 'An + 1' Address is written to during this cycle.

Functional Description

The IDT70V9279/69 provides a true synchronous Dual-Port Static RAM interface. Registered inputs provide minimal set-up and hold times on address, data, and all critical control inputs. All internal registers are clocked on the rising edge of the clock signal, however, the self-timed internal write pulse is independent of the LOW to HIGH transition of the clock signal.

An asynchronous output enable is provided to ease asynchronous bus interfacing. Counter enable inputs are also provided to staff the operation of the address counters for fast interleaved memory applications.

A HIGH on $\overline{CE_0}$ or a LOW on CE_1 for one clock cycle will power down the internal circuitry to reduce static power consumption. Multiple chip enables allow easier banking of multiple IDT70V9279/69's for depth expansion configurations. When the Pipelined output mode is enabled, two cycles are required with $\overline{CE_0}$ LOW and CE_1 HIGH to re-activate the outputs.

Depth and Width Expansion

The IDT70V9279/69 features dual chip enables (refer to Truth Table I) in order to facilitate rapid and simple depth expansion with no requirements for external logic. Figure 4 illustrates how to control the various chip enables in order to expand two devices in depth.

The IDT70V9279/69 can also be used in applications requiring expanded width, as indicated in Figure 4. Since the banks are allocated at the discretion of the user, the external controller can be set up to drive the input signals for the various devices as required to allow for 32-bit or wider applications.

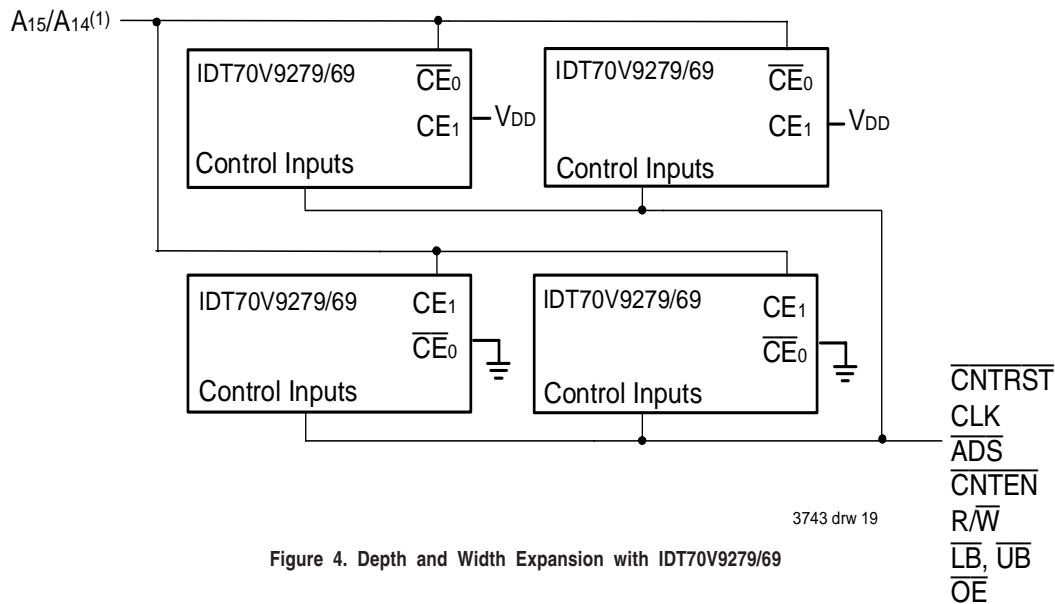
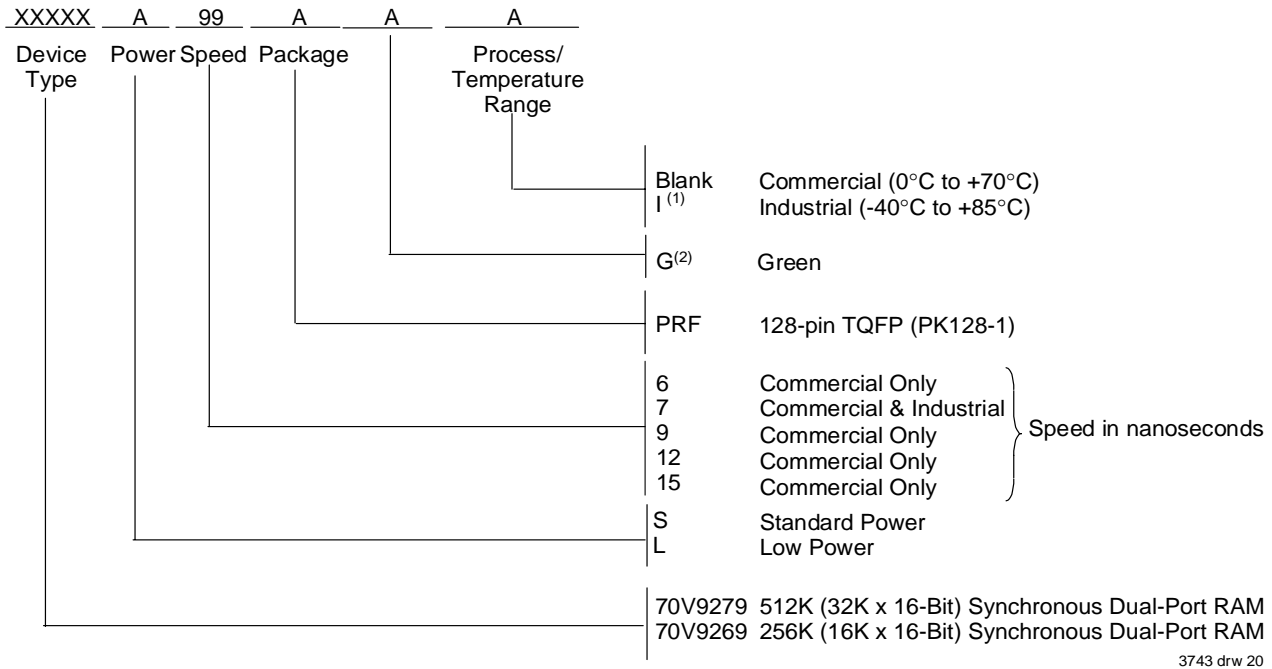

Figure 4. Depth and Width Expansion with IDT70V9279/69

NOTE:

1. A15 is for IDT70V9279. A14 is for IDT70V9269.

Ordering Information



NOTE:

1. Contact your local sales office for industrial temp. range for other speeds, packages and powers.
2. Green parts available. For specific speeds, packages and powers contact your local sales office.

Ordering Information for Flow-through Devices

Old Flow-through Part	New Combined Part
70V927S/L25	70V9279S/L12
70V927S/L30	70V9279S/L15

3743 tbl 12

IDT Clock Solution for IDT70V9279/69 Dual-Port

IDT Dual-Port Part Number	Dual-Port I/O Specifications		Clock Specifications				IDT PLL Clock Device	IDT Non-PLL Clock Device
	Voltage	I/O	Input Capacitance	Input Duty Cycle Requirement	Maximum Frequency	Jitter Tolerance		
70V9279/69	3.3	LVTTTL	9pF	40%	100	150ps	2305 2308 2309	49FCT3805 49FCT3805D/E 74FCT3807 74FCT3807D/E

3743 tbl 13

Datasheet Document History

01/12/99:		Initiated datasheet document history Converted to new format Cosmetic and typographical corrections Added additional notes to pin configurations
06/15/99:	Page 14	Added Depth & Width Expansion section
09/29/99:	Page 4	Deleted note 6 for Table II
11/10/99:	Page 7	Corrected typo in heading
03/31/00:		Replaced IDT logo Combined Pipelined 70V9279/69 family and Flow-through 70V927 family offerings into one data sheet Changed $\pm 200\text{mV}$ in waveform notes to 0mV Added corresponding part chart with ordering information
01/017/01:	Page 4	Changed information in Truth Table II Increased storage temperature parameters Clarified TA parameter
	Page 5	DC Electrical parameters—changed wording from "open" to "disabled" Removed Preliminary status
02/25/04:		Consolidated multiple devices into one datasheet Changed naming conventions from V _{CC} to V _{DD} and from GND to V _{SS}
	Page 2	Added date revision for pin configuration
	Page 3	Added footnotes for $\overline{\text{UB}}$, $\overline{\text{LB}}$, $\overline{\text{CE}}_0$ and CE1 buffer conditions when $\overline{\text{FT}}$ or PIPE
	Page 4	Added junction temperature to Absolute Maximum Ratings Table Added Ambient Temperature footnote
	Page 5	Added I-temp numbers for 9ns speed to DC Electrical Characteristics Table Added 6ns speed DC power numbers to the DC Electrical Characteristics Table
	Page 7	Added I-temp for 9ns speed to AC Electrical Characteristics Table Added 6ns speed AC timing numbers to the AC Electrical Characteristics Table
	Page 18	Added 6ns speed grade and 9ns I-temp to ordering information Added IDT Clock Solution Table
05/04/04:	Page 1 & 19	Updated IDT logo, replaced IDT™ logo with IDT® logo
	Page 1 & 18	Added 7ns speed grade to ordering information
	Page 5	Added 7ns speed DC power numbers to the DC Electrical Characteristics Table
	Page 8	Added 7ns speed AC timing numbers to the AC Electrical Characteristics Table
10/11/04:	Page 4	Updated Capacitance table
	Page 5	Added 7ns I-temp and removed 9ns I-temp DC power numbers from the DC Electrical Characteristics table
	Page 8	Added 7ns I-temp and removed 9ns I-temp from the AC Electrical Characteristics table
	Page 12	Added Timing Waveform of Left Port Write to Pipelined Right Port Read
	Page 18	Added 7ns I-temp and removed 9ns I-temp from ordering information
01/19/06:	Page 1	Added green availability to features
	Page 18	Added green indicator to ordering information
10/23/08:	Page 18	Removed "IDT" from orderable part number

CORPORATE HEADQUARTERS

6024 Silver Creek Valley Road
San Jose, CA 95138

for SALES:

800-345-7015 or 408-284-8200
fax: 408-284-2775
www.idt.com

for Tech Support:

408-284-2794
DualPortHelp@idt.com

The IDT logo is a registered trademark of Integrated Device Technology, Inc.