



**HIGH-SPEED 3.3V 32K x 36  
SYNCHRONOUS PIPELINED  
DUAL-PORT STATIC RAM  
WITH 3.3V OR 2.5V INTERFACE**

**IDT70V3579S**

**Features:**

- ◆ True Dual-Port memory cells which allow simultaneous access of the same memory location
- ◆ High-speed clock to data access
  - Commercial: 4.2/5/6ns (max.)
  - Industrial: 5ns (max)
- ◆ Pipelined output mode
- ◆ Counter enable and reset features
- ◆ Dual chip enables allow for depth expansion without additional logic
- ◆ Full synchronous operation on both ports
  - 7.5ns cycle time, 133MHz operation (9.6 Gbps bandwidth)
  - Fast 4.2ns clock to data out
  - 1.8ns setup to clock and 0.7ns hold on all control, data, and address inputs @ 133MHz

- Data input, address, byte enable and control registers
- Self-timed write allows fast cycle time
- ◆ Separate byte controls for multiplexed bus and bus matching compatibility
- ◆ LVTTTL-compatible, single 3.3V (±150mV) power supply for core
- ◆ LVTTTL compatible, selectable 3.3V (±150mV)/2.5V (±125mV) power supply for I/Os and control signals on each port
- ◆ Industrial temperature range (-40°C to +85°C) is available for selected speeds
- ◆ Available in a 208-pin Plastic Quad Flatpack (PQFP) and 208-pin fine pitch Ball Grid Array, and 256-pin Ball Grid Array
- ◆ Green parts available, see ordering information

**Functional Block Diagram**

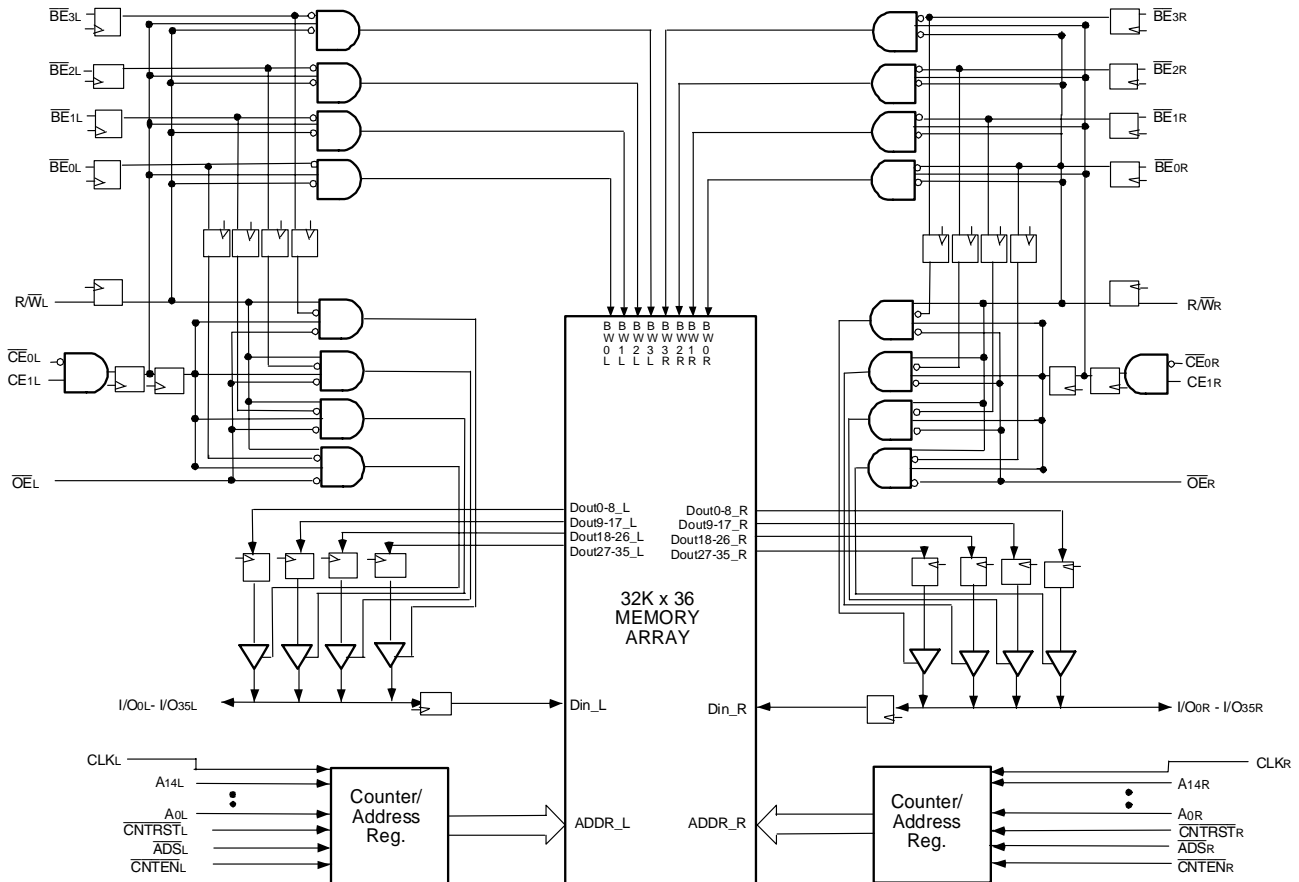

4830 tbl 01

**OCTOBER 2008**

## Description:

The IDT70V3579 is a high-speed 32K x 36 bit synchronous Dual-Port RAM. The memory array utilizes Dual-Port memory cells to allow simultaneous access of any address from both ports. Registers on control, data, and address inputs provide minimal setup and hold times. The timing latitude provided by this approach allows systems to be designed with very short cycle times. With an input data register, the IDT70V3579 has been optimized for applications having unidirectional or

bidirectional data flow in bursts. An automatic power down feature, controlled by  $\overline{CE}_0$  and  $\overline{CE}_1$ , permits the on-chip circuitry of each port to enter a very low standby power mode.

The 70V3579 can support an operating voltage of either 3.3V or 2.5V on one or both ports, controllable by the OPT pins. The power supply for the core of the device (VDD) remains at 3.3V.

## Pin Configuration<sup>(1,2,3,4)</sup>

12/12/01

A1 I/O19L	A2 I/O18L	A3 VSS	A4 NC	A5 NC	A6 NC	A7 A12L	A8 A8L	A9 $\overline{BE}_{1L}$	A10 VDD	A11 CLKL	A12 $\overline{CNTENL}$	A13 A4L	A14 A0L	A15 OPTL	A16 I/O17L	A17 VSS	
B1 I/O20R	B2 VSS	B3 I/O18R	B4 VSS	B5 NC	B6 A13L	B7 A9L	B8 $\overline{BE}_{2L}$	B9 $\overline{CE}_{0L}$	B10 VSS	B11 ADSL	B12 A5L	B13 A1L	B14 VSS	B15 VDDQR	B16 I/O16L	B17 I/O15R	
C1 VDDQL	C2 I/O19R	C3 VDDQR	C4 VDD	C5 NC	C6 A14L	C7 A10L	C8 $\overline{BE}_{3L}$	C9 $\overline{CE}_{1L}$	C10 VSS	C11 R/WL	C12 A6L	C13 A2L	C14 VDD	C15 I/O16R	C16 I/O15L	C17 VSS	
D1 I/O22L	D2 VSS	D3 I/O21L	D4 I/O20L	D5 NC	D6 A11L	D7 A7L	D8 $\overline{BE}_{0L}$	D9 VDD	D10 $\overline{OE}_{L}$	D11 $\overline{CNTBSTL}$	D12 A3L	D13 VDD	D14 I/O17R	D15 VDDQL	D16 I/O14L	D17 I/O14R	
E1 I/O23L	E2 I/O22R	E3 VDDQR	E4 I/O21R	<b>70V3579BF</b> <b>BF-208<sup>(5)</sup></b>  <b>208-Pin fpBGA</b> <b>Top View<sup>(6)</sup></b>										E14 I/O12L	E15 I/O13R	E16 VSS	E17 I/O13L
F1 VDDQL	F2 I/O23R	F3 I/O24L	F4 VSS											F14 VSS	F15 I/O12R	F16 I/O11L	F17 VDDQR
G1 I/O26L	G2 VSS	G3 I/O25L	G4 I/O24R											G14 I/O9L	G15 VDDQL	G16 I/O10L	G17 I/O11R
H1 VDD	H2 I/O26R	H3 VDDQR	H4 I/O25R											H14 VDD	H15 I/O9R	H16 VSS	H17 I/O10R
J1 VDDQL	J2 VDD	J3 VSS	J4 VSS											J14 VSS	J15 VDD	J16 VSS	J17 VDDQR
K1 I/O28R	K2 VSS	K3 I/O27R	K4 VSS											K14 I/O7R	K15 VDDQL	K16 I/O8R	K17 VSS
L1 I/O29R	L2 I/O28L	L3 VDDQR	L4 I/O27L											L14 I/O6R	L15 I/O7L	L16 VSS	L17 I/O8L
M1 VDDQL	M2 I/O29L	M3 I/O30R	M4 VSS											M14 VSS	M15 I/O6L	M16 I/O5R	M17 VDDQR
N1 I/O31L	N2 VSS	N3 I/O31R	N4 I/O30L											N14 I/O3R	N15 VDDQL	N16 I/O4R	N17 I/O5L
P1 I/O32R	P2 I/O32L	P3 VDDQR	P4 I/O35R											P5 NC	P6 NC	P7 A12R	P8 A8R
R1 VSS	R2 I/O33L	R3 I/O34R	R4 NC	R5 NC	R6 A13R	R7 A9R	R8 $\overline{BE}_{2R}$	R9 $\overline{CE}_{0R}$	R10 VSS	R11 ADSR	R12 A5R	R13 A1R	R14 VSS	R15 VDDQL	R16 I/O1R	R17 VDDQR	
T1 I/O33R	T2 I/O34L	T3 VDDQL	T4 VSS	T5 NC	T6 A14R	T7 A10R	T8 $\overline{BE}_{3R}$	T9 $\overline{CE}_{1R}$	T10 VSS	T11 R/WR	T12 A6R	T13 A2R	T14 VSS	T15 I/O0R	T16 VSS	T17 I/O2R	
U1 VSS	U2 I/O35L	U3 VDD	U4 NC	U5 NC	U6 A11R	U7 A7R	U8 $\overline{BE}_{0R}$	U9 VDD	U10 $\overline{OE}_{R}$	U11 $\overline{CNTBSTR}$	U12 A3R	U13 A0R	U14 VDD	U15 OPTR	U16 I/O0L	U17 I/O1L	

4830 drw 02c

### NOTES:

1. All VDD pins must be connected to 3.3V power supply.
2. All VDDQ pins must be connected to appropriate power supply: 3.3V if OPT pin for that port is set to V<sub>IH</sub> (3.3V), and 2.5V if OPT pin for that port is set to V<sub>IL</sub> (0V).
3. All VSS pins must be connected to ground supply.
4. Package body is approximately 15mm x 15mm x 1.4mm, with 0.8mm ball-pitch.
5. This package code is used to reference the package diagram.
6. This text does not indicate orientation of the actual part-marking.

Pin Configuration<sup>(1,2,3,4)</sup> (con't.)

70V3579BC  
BC-256<sup>(5)</sup>

256-Pin BGA  
Top View<sup>(6)</sup>

12/12/01

A1 NC	A2 NC	A3 NC	A4 NC	A5 A14L	A6 A11L	A7 A8L	A8 $\overline{BE}2L$	A9 CE1L	A10 $\overline{OE}L$	A11 $\overline{CNTEN}L$	A12 A5L	A13 A2L	A14 A0L	A15 NC	A16 NC
B1 I/O18L	B2 NC	B3 NC	B4 NC	B5 NC	B6 A12L	B7 A9L	B8 $\overline{BE}3L$	B9 $\overline{CE}0L$	B10 R/WL	B11 $\overline{CNTRST}L$	B12 A4L	B13 A1L	B14 VDD	B15 I/O17L	B16 NC
C1 I/O18R	C2 I/O19L	C3 VSS	C4 NC	C5 A13L	C6 A10L	C7 A7L	C8 $\overline{BE}1L$	C9 $\overline{BE}0L$	C10 CLKL	C11 $\overline{ADS}L$	C12 A6L	C13 A3L	C14 OPTL	C15 I/O17R	C16 I/O16L
D1 I/O20R	D2 I/O19R	D3 I/O20L	D4 VDD	D5 VDDQL	D6 VDDQL	D7 VDDQR	D8 VDDQR	D9 VDDQL	D10 VDDQL	D11 VDDQR	D12 VDDQR	D13 VDD	D14 I/O15R	D15 I/O15L	D16 I/O16R
E1 I/O21R	E2 I/O21L	E3 I/O22L	E4 VDDQL	E5 VDD	E6 VDD	E7 VSS	E8 VSS	E9 VSS	E10 VSS	E11 VDD	E12 VDD	E13 VDDQR	E14 I/O13L	E15 I/O14L	E16 I/O14R
F1 I/O23L	F2 I/O22R	F3 I/O23R	F4 VDDQL	F5 VDD	F6 VSS	F7 VSS	F8 VSS	F9 VSS	F10 VSS	F11 VSS	F12 VDD	F13 VDDQR	F14 I/O12R	F15 I/O13R	F16 I/O12L
G1 I/O24R	G2 I/O24L	G3 I/O25L	G4 VDDQR	G5 VSS	G6 VSS	G7 VSS	G8 VSS	G9 VSS	G10 VSS	G11 VSS	G12 VSS	G13 VDDQL	G14 I/O10L	G15 I/O11L	G16 I/O11R
H1 I/O26L	H2 I/O25R	H3 I/O26R	H4 VDDQR	H5 VSS	H6 VSS	H7 VSS	H8 VSS	H9 VSS	H10 VSS	H11 VSS	H12 VSS	H13 VDDQL	H14 I/O9R	H15 I/O9L	H16 I/O10R
J1 I/O27L	J2 I/O28R	J3 I/O27R	J4 VDDQL	J5 VSS	J6 VSS	J7 VSS	J8 VSS	J9 VSS	J10 VSS	J11 VSS	J12 VSS	J13 VDDQR	J14 I/O8R	J15 I/O7R	J16 I/O8L
K1 I/O29R	K2 I/O29L	K3 I/O28L	K4 VDDQL	K5 VSS	K6 VSS	K7 VSS	K8 VSS	K9 VSS	K10 VSS	K11 VSS	K12 VSS	K13 VDDQR	K14 I/O6R	K15 I/O6L	K16 I/O7L
L1 I/O30L	L2 I/O31R	L3 I/O30R	L4 VDDQR	L5 VDD	L6 VSS	L7 VSS	L8 VSS	L9 VSS	L10 VSS	L11 VSS	L12 VDD	L13 VDDQL	L14 I/O5L	L15 I/O4R	L16 I/O5R
M1 I/O32R	M2 I/O32L	M3 I/O31L	M4 VDDQR	M5 VDD	M6 VDD	M7 VSS	M8 VSS	M9 VSS	M10 VSS	M11 VDD	M12 VDD	M13 VDDQL	M14 I/O3R	M15 I/O3L	M16 I/O4L
N1 I/O33L	N2 I/O34R	N3 I/O33R	N4 VDD	N5 VDDQR	N6 VDDQR	N7 VDDQL	N8 VDDQL	N9 VDDQR	N10 VDDQR	N11 VDDQL	N12 VDDQL	N13 VDD	N14 I/O2L	N15 I/O1R	N16 I/O2R
P1 I/O35R	P2 I/O34L	P3 NC	P4 NC	P5 A13R	P6 A10R	P7 A7R	P8 $\overline{BE}1R$	P9 $\overline{BE}0R$	P10 CLKR	P11 $\overline{ADS}R$	P12 A6R	P13 A3R	P14 I/O0L	P15 I/O0R	P16 I/O1L
R1 I/O35L	R2 NC	R3 NC	R4 NC	R5 NC	R6 A12R	R7 A9R	R8 $\overline{BE}3R$	R9 $\overline{CE}0R$	R10 R/WR	R11 $\overline{CNTRST}R$	R12 A4R	R13 A1R	R14 OPTR	R15 NC	R16 NC
T1 NC	T2 NC	T3 NC	T4 NC	T5 A14R	T6 A11R	T7 A8R	T8 $\overline{BE}2R$	T9 CE1R	T10 $\overline{OE}R$	T11 $\overline{CNTEN}R$	T12 A5R	T13 A2R	T14 A0R	T15 NC	T16 NC

4830 drw 02d

NOTES:

1. All VDD pins must be connected to 3.3V power supply.
2. All VDDQ pins must be connected to appropriate power supply: 3.3V if OPT pin for that port is set to VIH (3.3V), and 2.5V if OPT pin for that port is set to VIL (0V).
3. All VSS pins must be connected to ground supply.
4. Package body is approximately 17mm x 17mm x 1.4mm, with 1.0mm ball-pitch.
5. This package code is used to reference the package diagram.
6. This text does not indicate orientation of the actual part-marking.

**Pin Configuration<sup>(1,2,3,4)</sup> (con't.)**

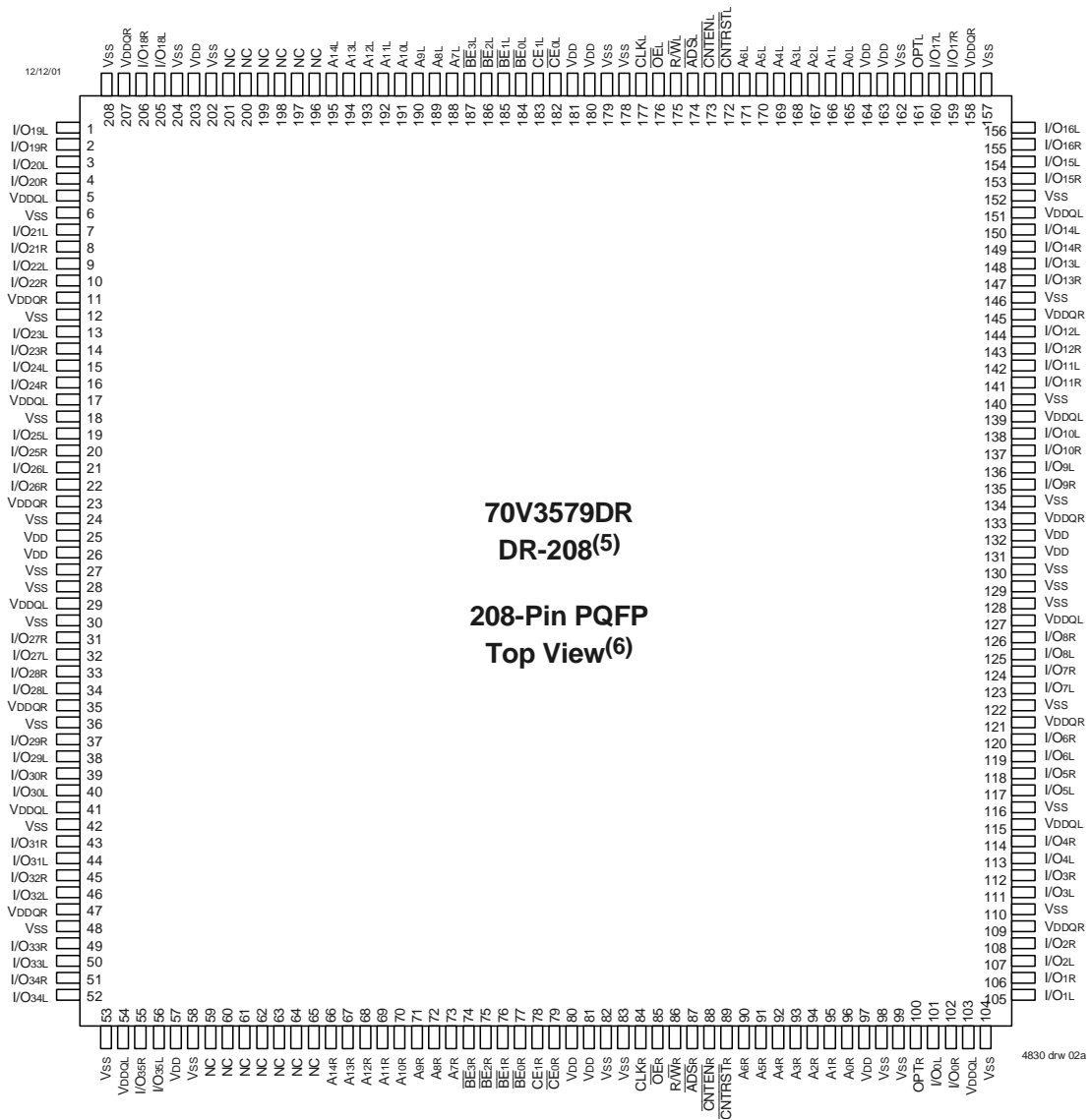

**NOTES:**

1. All VDD pins must be connected to 3.3V power supply.
2. All VDDQ pins must be connected to appropriate power supply: 3.3V if OPT pin for that port is set to VIH (3.3V), and 2.5V if OPT pin for that port is set to VIL (0V).
3. All VSS pins must be connected to ground supply.
4. Package body is approximately 28mm x 28mm x 3.5mm.
5. This package code is used to reference the package diagram.
6. This text does not indicate orientation of the actual part-marking.

## Pin Names

Left Port	Right Port	Names
$\overline{CE}_{0L}$ , $CE_{1L}$	$\overline{CE}_{0R}$ , $CE_{1R}$	Chip Enables
$R/\overline{WL}$	$R/\overline{WR}$	Read/Write Enable
$\overline{OE}_L$	$\overline{OE}_R$	Output Enable
$A_{0L}$ - $A_{14L}$	$A_{0R}$ - $A_{14R}$	Address
$I/O_{0L}$ - $I/O_{35L}$	$I/O_{0R}$ - $I/O_{35R}$	Data Input/Output
$CLK_L$	$CLK_R$	Clock
$\overline{ADS}_L$	$\overline{ADS}_R$	Address Strobe Enable
$\overline{CNTEN}_L$	$\overline{CNTEN}_R$	Counter Enable
$\overline{CNTRST}_L$	$\overline{CNTRST}_R$	Counter Reset
$\overline{BE}_{0L}$ - $\overline{BE}_{3L}$	$\overline{BE}_{0R}$ - $\overline{BE}_{3R}$	Byte Enables (9-bit bytes)
$V_{DDQL}$	$V_{DDQR}$	Power (I/O Bus) (3.3V or 2.5V) <sup>(1)</sup>
$OPT_L$	$OPT_R$	Option for selecting $V_{DDQX}$ <sup>(1,2)</sup>
$V_{DD}$		Power (3.3V) <sup>(1)</sup>
$V_{SS}$		Ground (0V)

4830 tbl 01

### NOTES:

- $V_{DD}$ ,  $OPT_X$ , and  $V_{DDQX}$  must be set to appropriate operating levels prior to applying inputs on the I/Os and controls for that port.
- $OPT_X$  selects the operating voltage levels on that port. If  $OPT_X$  is set to VIH (3.3V), then that port's I/Os and controls will operate at 3.3V levels and  $V_{DDQX}$  must be supplied at 3.3V. If  $OPT_X$  is set to VIL (0V), then that port's I/Os and controls will operate at 2.5V levels and  $V_{DDQX}$  must be supplied at 2.5V. The OPT pins are independent of one another—both ports can operate at 3.3V levels, both can operate at 2.5V levels, or either can operate at 3.3V with the other at 2.5V.

## Truth Table I—Read/Write and Enable Control<sup>(1,2,3,4)</sup>

$\overline{OE}$	CLK	$\overline{CE}_0$	$CE_1$	$\overline{BE}_3$	$\overline{BE}_2$	$\overline{BE}_1$	$\overline{BE}_0$	$R/\overline{W}$	Byte 3 I/O <sub>27-35</sub>	Byte 2 I/O <sub>18-26</sub>	Byte 1 I/O <sub>9-17</sub>	Byte 0 I/O <sub>0-8</sub>	MODE
X	↑	H	X	X	X	X	X	X	High-Z	High-Z	High-Z	High-Z	Deselected—Power Down
X	↑	X	L	X	X	X	X	X	High-Z	High-Z	High-Z	High-Z	Deselected—Power Down
X	↑	L	H	H	H	H	H	X	High-Z	High-Z	High-Z	High-Z	All Bytes Deselected
X	↑	L	H	H	H	H	L	L	High-Z	High-Z	High-Z	DIN	Write to Byte 0 Only
X	↑	L	H	H	H	L	H	L	High-Z	High-Z	DIN	High-Z	Write to Byte 1 Only
X	↑	L	H	H	L	H	H	L	High-Z	DIN	High-Z	High-Z	Write to Byte 2 Only
X	↑	L	H	L	H	H	H	L	DIN	High-Z	High-Z	High-Z	Write to Byte 3 Only
X	↑	L	H	H	H	L	L	L	High-Z	High-Z	DIN	DIN	Write to Lower 2 Bytes Only
X	↑	L	H	L	L	H	H	L	DIN	DIN	High-Z	High-Z	Write to Upper 2 bytes Only
X	↑	L	H	L	L	L	L	L	DIN	DIN	DIN	DIN	Write to All Bytes
L	↑	L	H	H	H	H	L	H	High-Z	High-Z	High-Z	DOUT	Read Byte 0 Only
L	↑	L	H	H	H	L	H	H	High-Z	High-Z	DOUT	High-Z	Read Byte 1 Only
L	↑	L	H	H	L	H	H	H	High-Z	DOUT	High-Z	High-Z	Read Byte 2 Only
L	↑	L	H	L	H	H	H	H	DOUT	High-Z	High-Z	High-Z	Read Byte 3 Only
L	↑	L	H	H	H	L	L	H	High-Z	High-Z	DOUT	DOUT	Read Lower 2 Bytes Only
L	↑	L	H	L	L	H	H	H	DOUT	DOUT	High-Z	High-Z	Read Upper 2 Bytes Only
L	↑	L	H	L	L	L	L	H	DOUT	DOUT	DOUT	DOUT	Read All Bytes
H	↑	L	H	L	L	L	L	X	High-Z	High-Z	High-Z	High-Z	Outputs Disabled

### NOTES:

- "H" = VIH, "L" = VIL, "X" = Don't Care.
- $\overline{ADS}$ ,  $\overline{CNTEN}$ ,  $\overline{CNTRST}$  = X.
- $\overline{OE}$  is an asynchronous input signal.
- It is possible to read or write any combination of bytes during a given access. A few representative samples have been illustrated here.

4830 tbl 02

Truth Table II—Address Counter Control<sup>(1,2)</sup>

Address	Previous Address	Addr Used	CLK <sup>(6)</sup>	$\overline{ADS}$	$\overline{CNTEN}$	$\overline{CNTRST}$	I/O <sup>(9)</sup>	MODE
X	X	0	↑	X	X	L <sup>(4)</sup>	D <sub>IO</sub> (0)	Counter Reset to Address 0
An	X	An	↑	L <sup>(4)</sup>	X	H	D <sub>IO</sub> (n)	External Address Used
An	Ap	Ap	↑	H	H	H	D <sub>IO</sub> (p)	External Address Blocked—Counter disabled (Ap reused)
X	Ap	Ap + 1	↑	H	L <sup>(5)</sup>	H	D <sub>IO</sub> (p+1)	Counter Enabled—Internal Address generation

## NOTES:

- "H" = V<sub>IH</sub>, "L" = V<sub>IL</sub>, "X" = Don't Care.
- Read and write operations are controlled by the appropriate setting of R $\overline{W}$ ,  $\overline{CE_0}$ , CE<sub>1</sub>,  $\overline{BEn}$  and  $\overline{OE}$ .
- Outputs are in Pipelined mode: the data out will be delayed by one cycle.
- $\overline{ADS}$  and  $\overline{CNTRST}$  are independent of all other memory control signals including  $\overline{CE_0}$ , CE<sub>1</sub> and  $\overline{BEn}$ .
- The address counter advances if  $\overline{CNTEN} = V_{IL}$  on the rising edge of CLK, regardless of all other memory control signals including  $\overline{CE_0}$ , CE<sub>1</sub>,  $\overline{BEn}$ .

4830 tbl 03

Recommended Operating Temperature and Supply Voltage<sup>(1)</sup>

Grade	Ambient Temperature	GND	V <sub>DD</sub>
Commercial	0°C to +70°C	0V	3.3V ± 150mV
Industrial	-40°C to +85°C	0V	3.3V ± 150mV

## NOTES:

- Industrial temperature: for specific speeds, packages and powers contact your sales office.

4830 tbl 04

Recommended DC Operating Conditions with V<sub>DDQ</sub> at 2.5V

Symbol	Parameter	Min.	Typ.	Max.	Unit
V <sub>DD</sub>	Core Supply Voltage	3.15	3.3	3.45	V
V <sub>DDQ</sub>	I/O Supply Voltage <sup>(6)</sup>	2.375	2.5	2.625	V
V <sub>SS</sub>	Ground	0	0	0	V
V <sub>IH</sub>	Input High Voltage <sup>(9)</sup> (Address & Control Inputs)	1.7	—	V <sub>DDQ</sub> + 125mV <sup>(2)</sup>	V
V <sub>IH</sub>	Input High Voltage - I/O <sup>(9)</sup>	1.7	—	V <sub>DDQ</sub> + 125mV <sup>(2)</sup>	V
V <sub>IL</sub>	Input Low Voltage	-0.3 <sup>(1)</sup>	—	0.7	V

## NOTES:

- V<sub>IL</sub> ≥ -1.5V for pulse width less than 10 ns.
- V<sub>TERM</sub> must not exceed V<sub>DDQ</sub> + 125mV.
- To select operation at 2.5V levels on the I/Os and controls of a given port, the OPT pin for that port must be set to V<sub>IL</sub> (0V), and V<sub>DDQX</sub> for that port must be supplied as indicated above.

4830 tbl 05a

Absolute Maximum Ratings<sup>(1)</sup>

Symbol	Rating	Commercial & Industrial	Unit
V <sub>TERM</sub> <sup>(2)</sup>	Terminal Voltage with Respect to GND	-0.5 to +4.6	V
T <sub>BIAS</sub>	Temperature Under Bias	-55 to +125	°C
T <sub>STG</sub>	Storage Temperature	-65 to +150	°C
I <sub>OUT</sub>	DC Output Current	50	mA

## NOTES:

- Stresses greater than those listed under ABSOLUTE MAXIMUM RATINGS may cause permanent damage to the device. This is a stress rating only and functional operation of the device at these or any other conditions above those indicated in the operational sections of this specification is not implied. Exposure to absolute maximum rating conditions for extended periods may affect reliability.
- V<sub>TERM</sub> must not exceed V<sub>DD</sub> + 150mV for more than 25% of the cycle time or 4ns maximum, and is limited to ≤ 20mA for the period of V<sub>TERM</sub> ≥ V<sub>DD</sub> + 150mV.

4830 tbl 06

Recommended DC Operating Conditions with V<sub>DDQ</sub> at 3.3V

Symbol	Parameter	Min.	Typ.	Max.	Unit
V <sub>DD</sub>	Core Supply Voltage	3.15	3.3	3.45	V
V <sub>DDQ</sub>	I/O Supply Voltage <sup>(6)</sup>	3.15	3.3	3.45	V
V <sub>SS</sub>	Ground	0	0	0	V
V <sub>IH</sub>	Input High Voltage (Address & Control Inputs) <sup>(9)</sup>	2.0	—	V <sub>DDQ</sub> + 150mV <sup>(2)</sup>	V
V <sub>IH</sub>	Input High Voltage - I/O <sup>(9)</sup>	2.0	—	V <sub>DDQ</sub> + 150mV <sup>(2)</sup>	V
V <sub>IL</sub>	Input Low Voltage	-0.3 <sup>(1)</sup>	—	0.8	V

## NOTES:

- V<sub>IL</sub> ≥ -1.5V for pulse width less than 10 ns.
- V<sub>TERM</sub> must not exceed V<sub>DDQ</sub> + 150mV.
- To select operation at 3.3V levels on the I/Os and controls of a given port, the OPT pin for that port must be set to V<sub>IH</sub> (3.3V), and V<sub>DDQX</sub> for that port must be supplied as indicated above.

4830 tbl 05b

## Capacitance<sup>(1)</sup>

( $T_A = +25^\circ\text{C}$ ,  $F = 1.0\text{MHz}$ ) PQFP ONLY

Symbol	Parameter	Conditions <sup>(2)</sup>	Max.	Unit
C <sub>IN</sub>	Input Capacitance	V <sub>IN</sub> = 3dV	8	pF
C <sub>OUT</sub> <sup>(3)</sup>	Output Capacitance	V <sub>OUT</sub> = 3dV	10.5	pF

4830 tbl 07

### NOTES:

- These parameters are determined by device characterization, but are not production tested.
- 3dV references the interpolated capacitance when the input and output switch from 0V to 3V or from 3V to 0V.
- C<sub>OUT</sub> also references C<sub>IO</sub>.

## DC Electrical Characteristics Over the Operating Temperature and Supply Voltage Range ( $V_{DD} = 3.3\text{V} \pm 150\text{mV}$ )

Symbol	Parameter	Test Conditions	70V3579S		Unit
			Min.	Max.	
I <sub>L</sub> I	Input Leakage Current <sup>(1)</sup>	V <sub>DDQ</sub> = Max., V <sub>IN</sub> = 0V to V <sub>DDQ</sub>	—	10	μA
I <sub>L</sub> O	Output Leakage Current	$\overline{CE_0} = V_{IH}$ or $CE_1 = V_{IL}$ , V <sub>OUT</sub> = 0V to V <sub>DDQ</sub>	—	10	μA
V <sub>OL</sub> (3.3V)	Output Low Voltage <sup>(2)</sup>	I <sub>OL</sub> = +4mA, V <sub>DDQ</sub> = Min.	—	0.4	V
V <sub>OH</sub> (3.3V)	Output High Voltage <sup>(2)</sup>	I <sub>OH</sub> = -4mA, V <sub>DDQ</sub> = Min.	2.4	—	V
V <sub>OL</sub> (2.5V)	Output Low Voltage <sup>(2)</sup>	I <sub>OL</sub> = +2mA, V <sub>DDQ</sub> = Min.	—	0.4	V
V <sub>OH</sub> (2.5V)	Output High Voltage <sup>(2)</sup>	I <sub>OH</sub> = -2mA, V <sub>DDQ</sub> = Min.	2.0	—	V

4830 tbl 08

### NOTE:

- At V<sub>DD</sub> ≤ -2.0V input leakages are undefined.
- V<sub>DDQ</sub> is selectable (3.3V/2.5V) via OPT pins. Refer to p.4 for details.

## DC Electrical Characteristics Over the Operating Temperature and Supply Voltage Range<sup>(3)</sup> ( $V_{DD} = 3.3V \pm 150mV$ )

Symbol	Parameter	Test Condition	Version	70V3579S4 Com'l Only		70V3579S5 Com'l & Ind		70V3579S6 Com'l Only		Unit	
				Typ. <sup>(4)</sup>	Max.	Typ. <sup>(4)</sup>	Max.	Typ. <sup>(4)</sup>	Max.		
IDD	Dynamic Operating Current (Both Ports Active)	$\overline{CE}_L$ and $\overline{CE}_R = V_{IL}$ , Outputs Disabled, $f = f_{MAX}^{(1)}$	COM'L	S	375	460	285	360	245	310	mA
			IND	S	—	—	285	415	245	360	
ISB1	Standby Current (Both Ports - TTL Level Inputs)	$\overline{CE}_L = \overline{CE}_R = V_{IH}$ $f = f_{MAX}^{(1)}$	COM'L	S	145	190	105	145	95	125	mA
			IND	S	—	—	105	175	95	150	
ISB2	Standby Current (One Port - TTL Level Inputs)	$\overline{CE}^*A^* = V_{IL}$ and $\overline{CE}^*B^* = V_{IH}^{(5)}$ Active Port Outputs Disabled, $f = f_{MAX}^{(1)}$	COM'L	S	265	325	190	260	175	225	mA
			IND	S	—	—	190	300	175	260	
ISB3	Full Standby Current (Both Ports - CMOS Level Inputs)	Both Ports $\overline{CE}_L$ and $\overline{CE}_R \geq V_{DDQ} - 0.2V$ , $V_{IN} \geq V_{DDQ} - 0.2V$ or $V_{IN} \leq 0.2V$ , $f = 0^{(2)}$	COM'L	S	6	15	6	15	6	15	mA
			IND	S	—	—	6	30	6	30	
ISB4	Full Standby Current (One Port - CMOS Level Inputs)	$\overline{CE}^*A^* \leq 0.2V$ and $\overline{CE}^*B^* \geq V_{DDQ} - 0.2V^{(5)}$ $V_{IN} \geq V_{DDQ} - 0.2V$ or $V_{IN} \leq 0.2V$ , Active Port, Outputs Disabled, $f = f_{MAX}^{(1)}$	COM'L	S	265	325	180	260	170	225	mA
			IND	S	—	—	180	300	170	260	

4830 tbl 09

**NOTES:**

- At  $f = f_{MAX}$ , address and control lines (except Output Enable) are cycling at the maximum frequency clock cycle of 1/tcvc, using "AC TEST CONDITIONS" at input levels of GND to 3V.
- $f = 0$  means no address, clock, or control lines change. Applies only to input at CMOS level standby.
- Port "A" may be either left or right port. Port "B" is the opposite from port "A".
- $V_{DD} = 3.3V$ ,  $T_A = 25^\circ C$  for Typ, and are not production tested.  $I_{DD} DC(f=0) = 120mA$  (Typ).
- $\overline{CE}_X = V_{IL}$  means  $\overline{CE}_{0X} = V_{IL}$  and  $CE_{1X} = V_{IH}$   
 $\overline{CE}_X = V_{IH}$  means  $\overline{CE}_{0X} = V_{IH}$  or  $CE_{1X} = V_{IL}$   
 $\overline{CE}_X \leq 0.2V$  means  $\overline{CE}_{0X} \leq 0.2V$  and  $CE_{1X} \geq V_{DDQ} - 0.2V$   
 $\overline{CE}_X \geq V_{DDQ} - 0.2V$  means  $\overline{CE}_{0X} \geq V_{DDQ} - 0.2V$  or  $CE_{1X} = 0.2V$   
"X" represents "L" for left port or "R" for right port.

### AC Test Conditions (V<sub>DDQ</sub> - 3.3V/2.5V)

Input Pulse Levels (Address & Controls)	GND to 3.0V/GND to 2.35V
Input Pulse Levels (I/Os)	GND to 3.0V/GND to 2.35V
Input Rise/Fall Times	3ns
Input Timing Reference Levels	1.5V/1.25V
Output Reference Levels	1.5V/1.25V
Output Load	Figures 1, 2, and 3

4830 tbl 10

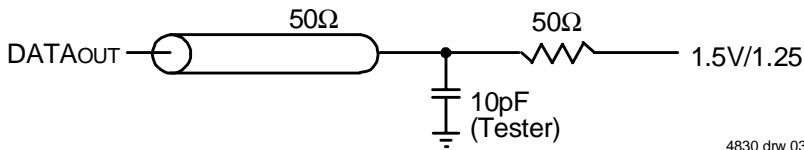
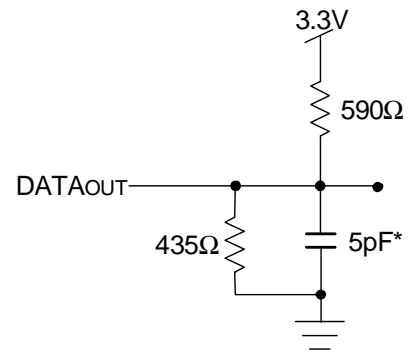
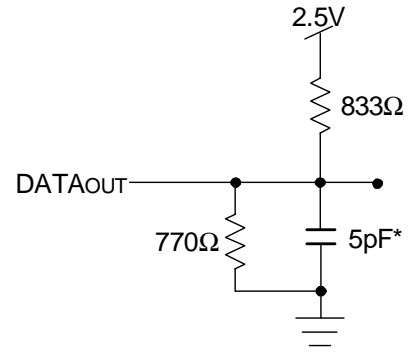

Figure 1. AC Output Test load.

4830 drw 03



4830 drw 04

Figure 2. Output Test Load  
(For t<sub>CKLZ</sub>, t<sub>CKHZ</sub>, t<sub>OLZ</sub>, and t<sub>OHZ</sub>).  
\*Including scope and jig.

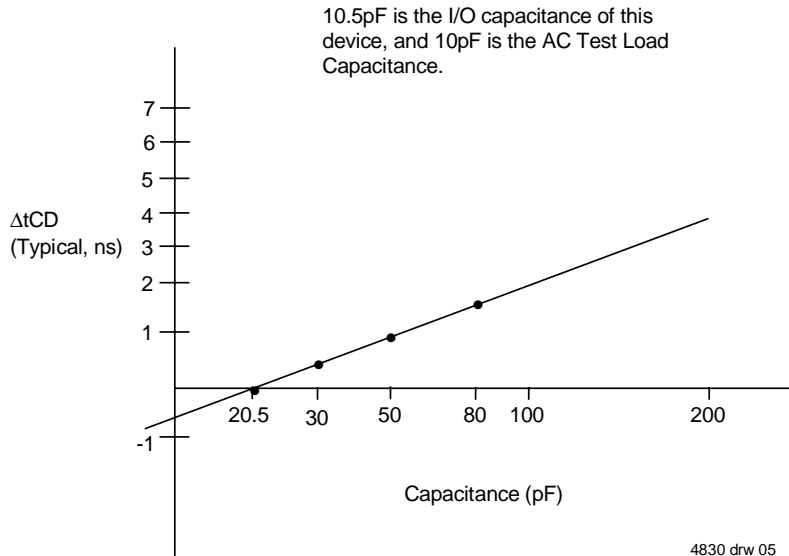

4830 drw 05

Figure 3. Typical Output Derating (Lumped Capacitive Load).

## AC Electrical Characteristics Over the Operating Temperature Range (Read and Write Cycle Timing)<sup>(1,2)</sup>

(V<sub>DD</sub> = 3.3V ± 150mV, T<sub>A</sub> = 0°C to +70°C)

Symbol	Parameter	70V3579S4 Com'l Only		70V3579S5 Com'l & Ind		70V3579S6 Com'l Only		Unit
		Min.	Max.	Min.	Max.	Min.	Max.	
t <sub>CYC2</sub>	Clock Cycle Time (Pipelined)	7.5	—	10	—	12	—	ns
t <sub>CH2</sub>	Clock High Time (Pipelined)	3	—	4	—	5	—	ns
t <sub>CL2</sub>	Clock Low Time (Pipelined)	3	—	4	—	5	—	ns
t <sub>R</sub>	Clock Rise Time	—	3	—	3	—	3	ns
t <sub>F</sub>	Clock Fall Time	—	3	—	3	—	3	ns
t <sub>SA</sub>	Address Setup Time	1.8	—	2.0	—	2.0	—	ns
t <sub>HA</sub>	Address Hold Time	0.7	—	0.7	—	1.0	—	ns
t <sub>SC</sub>	Chip Enable Setup Time	1.8	—	2.0	—	2.0	—	ns
t <sub>HC</sub>	Chip Enable Hold Time	0.7	—	0.7	—	1.0	—	ns
t <sub>SB</sub>	Byte Enable Setup Time	1.8	—	2.0	—	2.0	—	ns
t <sub>HB</sub>	Byte Enable Hold Time	0.7	—	0.7	—	1.0	—	ns
t <sub>SW</sub>	R/W Setup Time	1.8	—	2.0	—	2.0	—	ns
t <sub>HW</sub>	R/W Hold Time	0.7	—	0.7	—	1.0	—	ns
t <sub>SD</sub>	Input Data Setup Time	1.8	—	2.0	—	2.0	—	ns
t <sub>HD</sub>	Input Data Hold Time	0.7	—	0.7	—	1.0	—	ns
t <sub>SAD</sub>	$\overline{ADS}$ Setup Time	1.8	—	2.0	—	2.0	—	ns
t <sub>HAD</sub>	$\overline{ADS}$ Hold Time	0.7	—	0.7	—	1.0	—	ns
t <sub>SCN</sub>	$\overline{CNTEN}$ Setup Time	1.8	—	2.0	—	2.0	—	ns
t <sub>HCN</sub>	$\overline{CNTEN}$ Hold Time	0.7	—	0.7	—	1.0	—	ns
t <sub>SRST</sub>	$\overline{CNTNST}$ Setup Time	1.8	—	2.0	—	2.0	—	ns
t <sub>HRST</sub>	$\overline{CNTNST}$ Hold Time	0.7	—	0.7	—	1.0	—	ns
t <sub>OE<sup>(1)</sup></sub>	Output Enable to Data Valid	—	4	—	5	—	6	ns
t <sub>OLZ</sub>	Output Enable to Output Low-Z	0	—	0	—	0	—	ns
t <sub>OHZ</sub>	Output Enable to Output High-Z	1	4	1	4.5	1	5	ns
t <sub>CD2</sub>	Clock to Data Valid (Pipelined)	—	4.2	—	5	—	6	ns
t <sub>DC</sub>	Data Output Hold After Clock High	1	—	1	—	1	—	ns
t <sub>CKHZ</sub>	Clock High to Output High-Z	1	3	1	4.5	1.5	6	ns
t <sub>CKLZ</sub>	Clock High to Output Low-Z	1	—	1	—	1	—	ns
<b>Port-to-Port Delay</b>								
t <sub>CO</sub>	Clock-to-Clock Offset	6	—	8	—	10	—	ns

**NOTES:**

1. All input signals are synchronous with respect to the clock except for the asynchronous Output Enable ( $\overline{OE}$ ).
2. These values are valid for either level of V<sub>DD0</sub> (3.3V/2.5V). See page 4 for details on selecting the desired I/O voltage levels for each port.

4830 bl 11

## Timing Waveform of Read Cycle for Pipelined Operation<sup>(2)</sup>

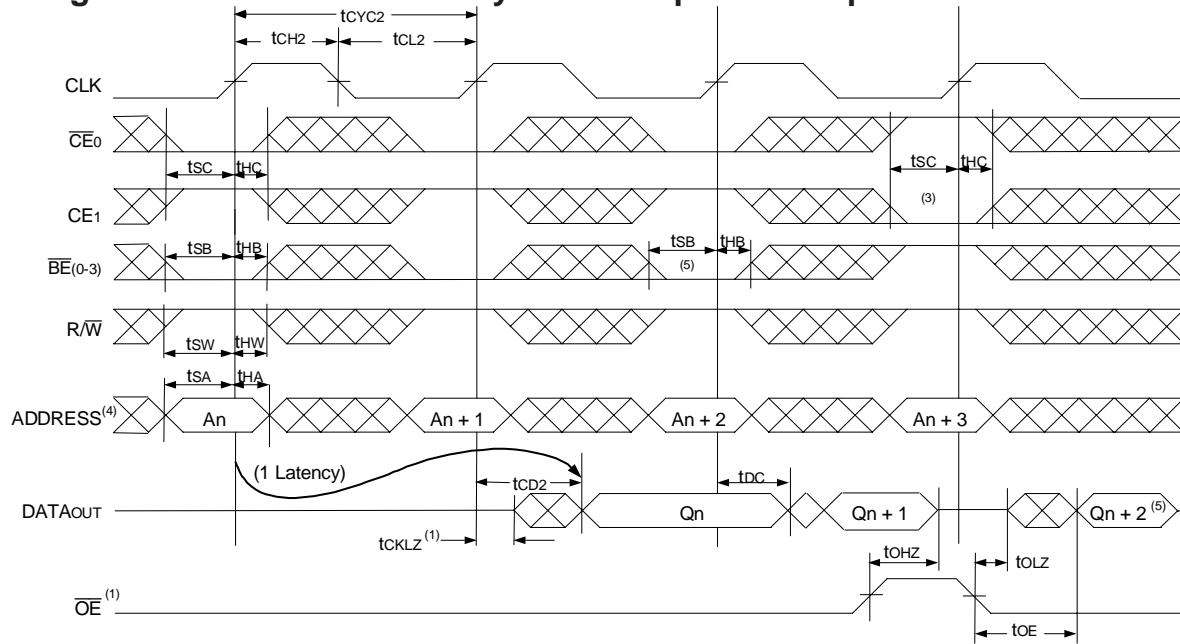

**NOTES:**

1.  $\overline{OE}$  is asynchronously controlled; all other inputs are synchronous to the rising clock edge.
2.  $\overline{ADS} = V_{IL}$ ,  $\overline{CNTEN}$  and  $\overline{CNRST} = V_{IH}$ .
3. The output is disabled (High-Impedance state) by  $\overline{CE}_0 = V_{IH}$ ,  $CE_1 = V_{IL}$ ,  $\overline{BE}_n = V_{IH}$  following the next rising edge of the clock. Refer to Truth Table 1.
4. Addresses do not have to be accessed sequentially since  $\overline{ADS} = V_{IL}$  constantly loads the address on the rising edge of the CLK; numbers are for reference use only.
5. If  $\overline{BE}_n$  was HIGH, then the appropriate Byte of DATAOUT for  $Q_{n+2}$  would be disabled (High-Impedance state).

4830 drw 06

## Timing Waveform of a Multi-Device Pipelined Read<sup>(1,2)</sup>

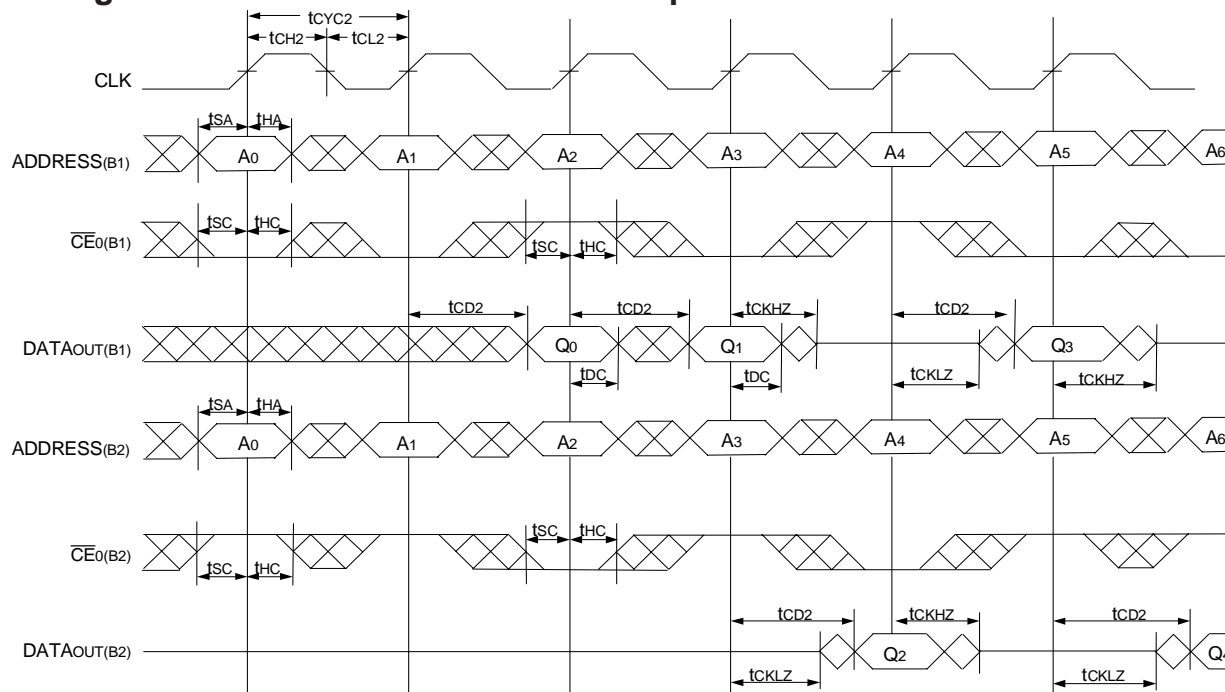

**NOTES:**

1. B1 Represents Device #1; B2 Represents Device #2. Each Device consists of one IDT70V3579 for this waveform, and are setup for depth expansion in this example.  $ADDRESS_{(B1)} = ADDRESS_{(B2)}$  in this situation.
2.  $\overline{BE}_n$ ,  $\overline{OE}$ , and  $\overline{ADS} = V_{IL}$ ;  $CE_1(B1)$ ,  $CE_1(B2)$ ,  $R/\overline{W}$ ,  $\overline{CNTEN}$ , and  $\overline{CNRST} = V_{IH}$ .

4830 drw 07



## Timing Waveform of Pipelined Read-to-Write-to-Read ( $\overline{OE}$ Controlled)<sup>(2)</sup>

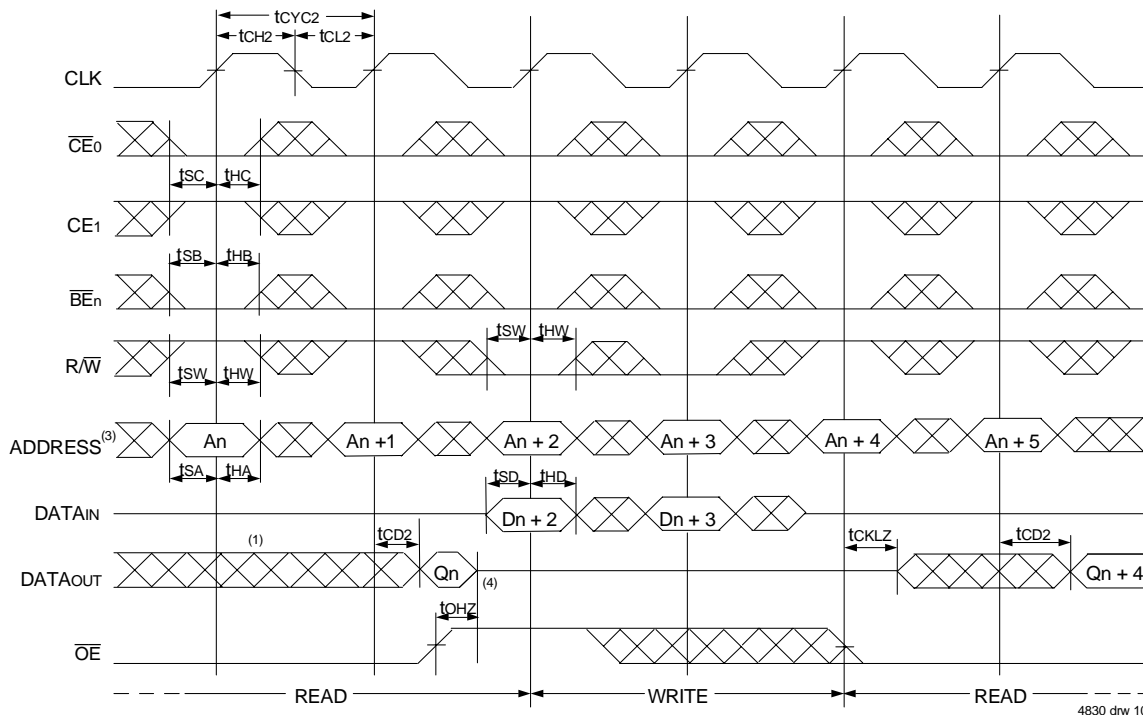

**NOTES:**

1. Output state (High, Low, or High-impedance) is determined by the previous cycle control signals.
2.  $\overline{CE}_0$ ,  $\overline{BE}_n$ , and  $\overline{ADS} = V_{IL}$ ;  $\overline{CE}_1$ ,  $\overline{CNTEN}$ , and  $\overline{CNTNST} = V_{IH}$ .
3. Addresses do not have to be accessed sequentially since  $\overline{ADS} = V_{IL}$  constantly loads the address on the rising edge of the CLK; numbers are for reference use only.
4. This timing does not meet requirements for fastest speed grade. This waveform indicates how logically it could be done if timing so allows.

## Timing Waveform of Pipelined Read with Address Counter Advance<sup>(1)</sup>

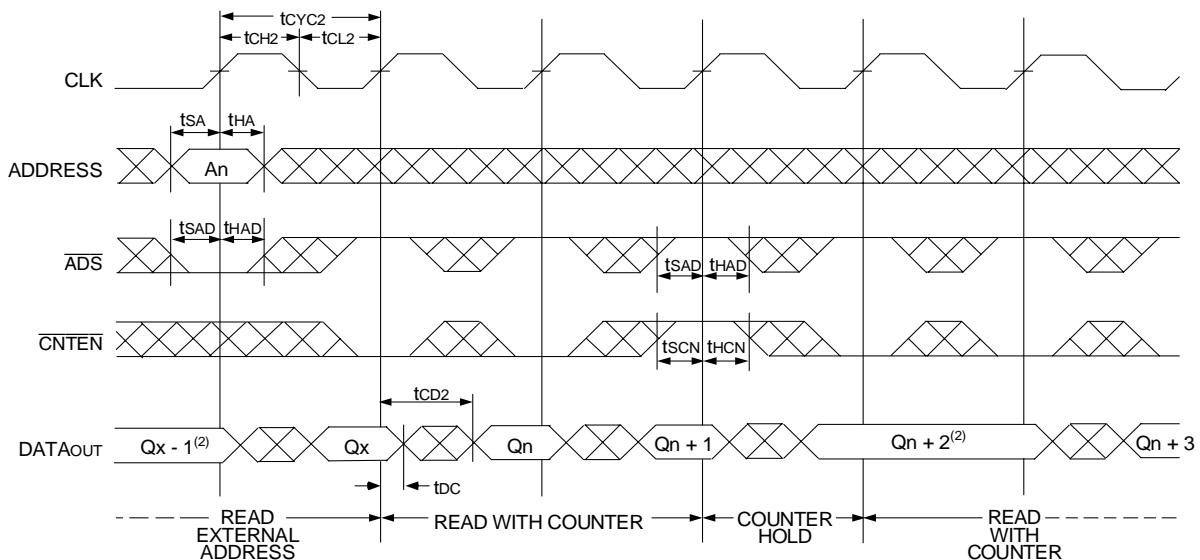

**NOTES:**

1.  $\overline{CE}_0$ ,  $\overline{OE}$ ,  $\overline{BE}_n = V_{IL}$ ;  $\overline{CE}_1$ ,  $\overline{R/W}$ , and  $\overline{CNTNST} = V_{IH}$ .
2. If there is no address change via  $\overline{ADS} = V_{IL}$  (loading a new address) or  $\overline{CNTEN} = V_{IL}$  (advancing the address), i.e.  $\overline{ADS} = V_{IH}$  and  $\overline{CNTEN} = V_{IH}$ , then the data output remains constant for subsequent clocks.

### Timing Waveform of Write with Address Counter Advance<sup>(1)</sup>

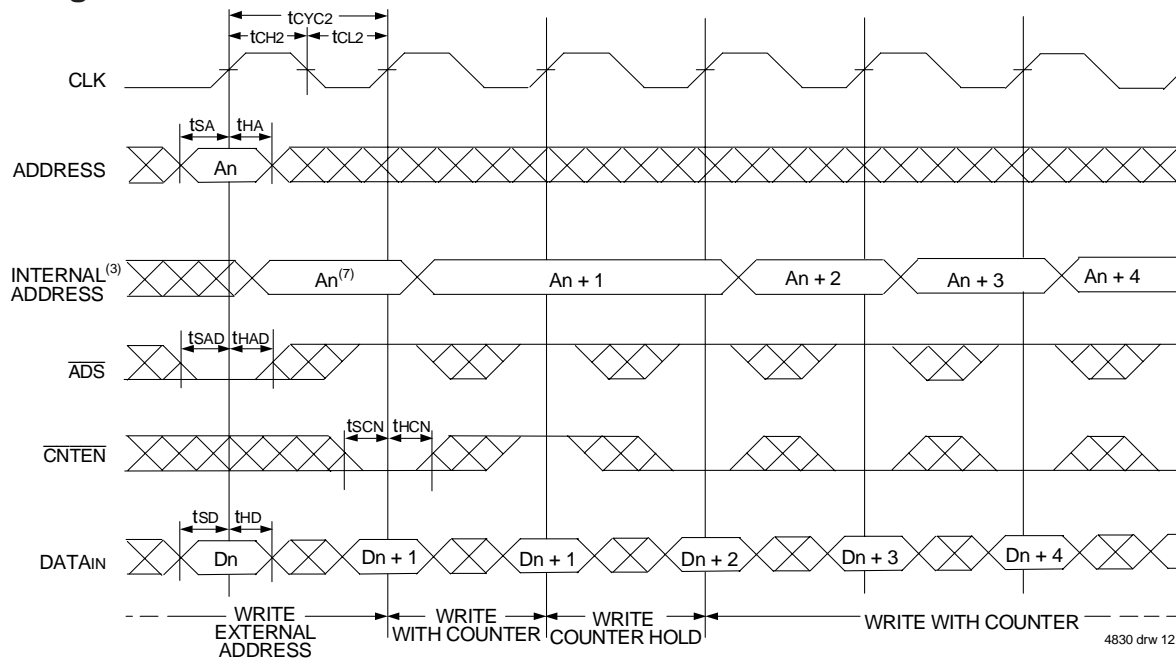

### Timing Waveform of Counter Reset<sup>(2)</sup>

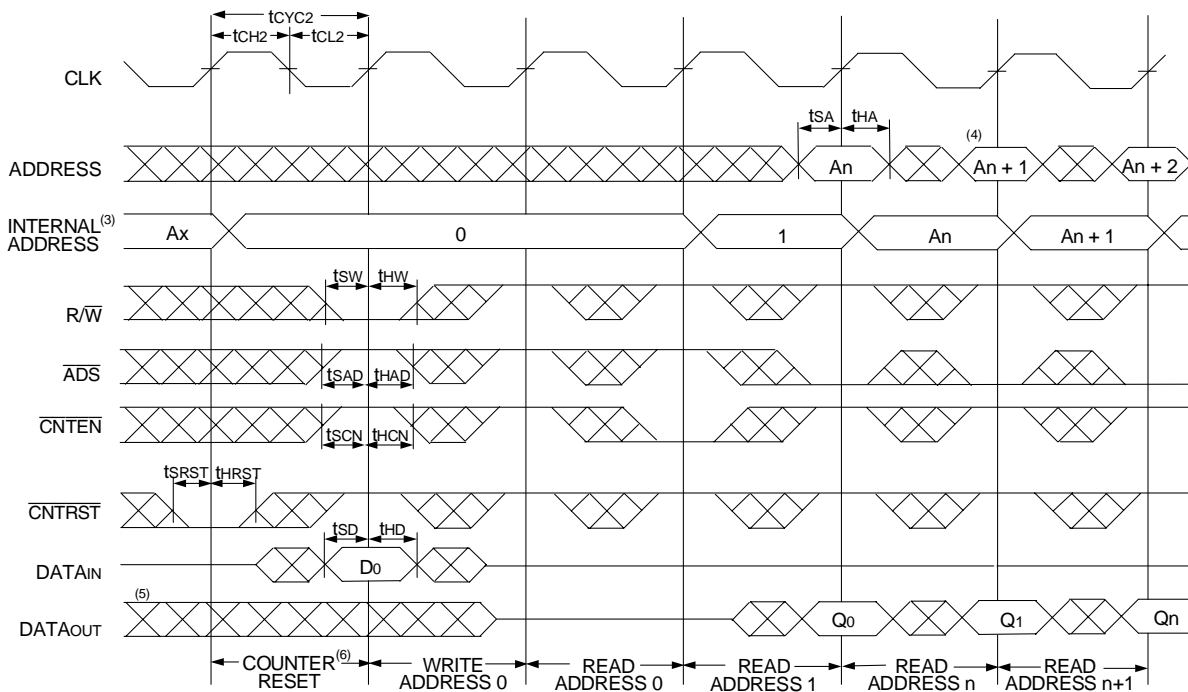

**NOTES:**

1.  $\overline{CE}_0$ ,  $\overline{BE}_n$ , and  $R/\overline{W} = V_{IL}$ ;  $CE_1$  and  $\overline{CNTRST} = V_{IH}$ .
2.  $\overline{CE}_0$ ,  $\overline{BE}_n = V_{IL}$ ;  $CE_1 = V_{IH}$ .
3. The "Internal Address" is equal to the "External Address" when  $\overline{ADS} = V_{IL}$  and equals the counter output when  $\overline{ADS} = V_{IH}$ .
4. Addresses do not have to be accessed sequentially since  $\overline{ADS} = V_{IL}$  constantly loads the address on the rising edge of the CLK; numbers are for reference use only.
5. Output state (High, Low, or High-impedance) is determined by the previous cycle control signals.
6. No dead cycle exists during counter reset. A READ or WRITE cycle may be coincidental with the counter reset cycle: Addr 0 will be accessed. Extra cycles are shown here simply for clarification.
7.  $CNTEN = V_{IL}$  advances Internal Address from 'An' to 'An + 1'. The transition shown indicates the time required for the counter to advance. The 'An + 1' Address is written to during this cycle.

## Functional Description

The IDT70V3579 provides a true synchronous Dual-Port Static RAM interface. Registered inputs provide minimal set-up and hold times on address, data, and all critical control inputs. All internal registers are clocked on the rising edge of the clock signal, however, the self-timed internal write pulse is independent of the LOW to HIGH transition of the clock signal.

An asynchronous output enable is provided to ease asynchronous bus interfacing. Counter enable inputs are also provided to stall the operation of the address counters for fast interleaved memory applications.

A HIGH on  $\overline{CE_0}$  or a LOW on  $CE_1$  for one clock cycle will power down the internal circuitry to reduce static power consumption. Multiple chip enables allow easier banking of multiple IDT70V3579s for depth expansion configurations. Two cycles are required with  $\overline{CE_0}$  LOW and  $CE_1$  HIGH to re-activate the outputs.

## Depth and Width Expansion

The IDT70V3579 features dual chip enables (refer to Truth Table I) in order to facilitate rapid and simple depth expansion with no requirements for external logic. Figure 4 illustrates how to control the various chip enables in order to expand two devices in depth.

The IDT70V3579 can also be used in applications requiring expanded width, as indicated in Figure 4. Through combining the control signals, the devices can be grouped as necessary to accommodate applications needing 72-bits or wider.

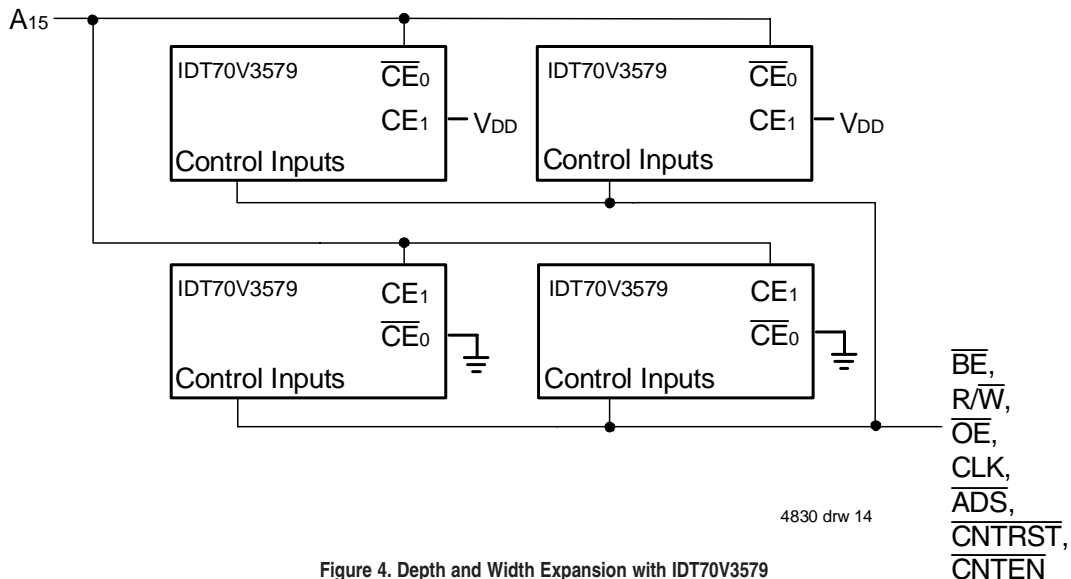
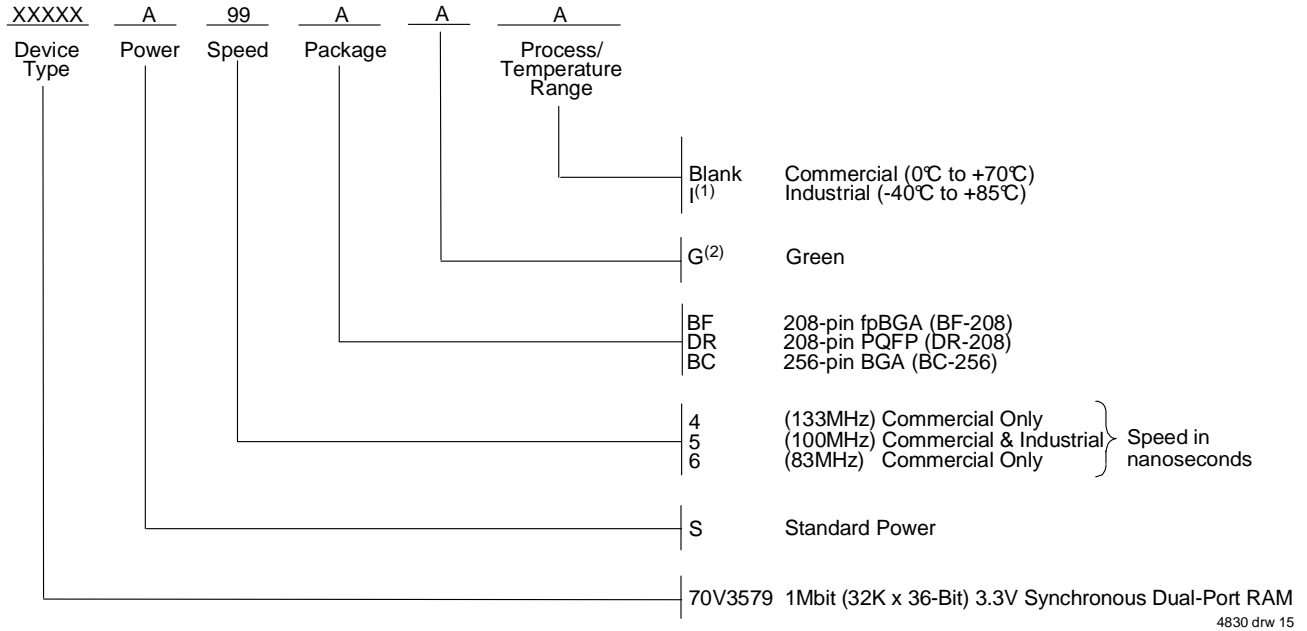

Figure 4. Depth and Width Expansion with IDT70V3579

## Ordering Information



**NOTE:**

1. Contact your local sales office for Industrial temp range in other speeds, packages and powers.
2. Green parts available. For specific speeds, packages and powers contact your local sales office.

## Datasheet Document History

- 12/9/98: Initial Public Release
- 3/12/99: Added fpBGA package
- 4/28/99: Fixed typo on page 10
- 6/8/99: Changed drawing format
  - Page 2 Changed package body dimensions
- 6/15/99: Page 5 Deleted note 6 for Table II
- 8/4/99: Page 6 Improved power numbers
- 10/4/99: Upgraded speed to 133MHz, added 2.5V I/O capability
- 10/19/99: Page 4 Corrected I/O numbers in Truth Table I
- 11/12/99: Replaced IDT logo
- 4/10/00: Added new BGA package, added full 2.5V interface capability
- 1/12/01: Page 6 Updated Truth Table II
  - Increated storage temperature parameter
  - Clarified TA Parameter
- Page 8 DC Electrical parameters—changed wording from "open" to "disabled"
  - Removed note 7 on DC Electrical Characteristics table
- Removed Preliminary status

## Datasheet Document History (cont'd)

4/10/01:	Added Industrial Temperature Ranges and removed related notes
7/19/01:	Page 3 Replaced incorrect BGA package drawing
12/12/01:	Page 2, 3 & 4 Added date revision to pin configurations Page 6 Removed industrial temp footnote from table 04 Page 8 & 10 Removed industrial temp for 6ns from DC & AC Electrical Characteristics Page 16 Removed industrial temp from 6ns in ordering information Added industrial temp footnote Page 1 & 17 Replaced $\text{TM}$ logo with $\text{®}$ logo
02/07/06:	Page 1 Added green availability to features Page 5 Changed footnote 2 for Truth Table I from $\overline{\text{ADS}}, \overline{\text{CNTEN}}, \overline{\text{CNTRST}} = V_{\text{IH}}$ to $\overline{\text{ADS}}, \overline{\text{CNTEN}}, \overline{\text{CNTRST}} = X$ Page 16 Added green indicator to ordering information
07/25/08:	Page 8 Corrected a typo in the DC Chars table
10/23/08:	Page 16 Removed "IDT" from orderable part number



**CORPORATE HEADQUARTERS**  
6024 Silver Creek Valley Road  
San Jose, CA 95138

**for SALES:**  
800-345-7015 or 408-284-8200  
fax: 408-284-2775  
www.idt.com

**for Tech Support:**  
408-284-2794  
DualPortHelp@idt.com

The IDT logo is a registered trademark of Integrated Device Technology, Inc.