



# HIGH-SPEED 32/16K x 18 SYNCHRONOUS PIPELINED DUAL-PORT STATIC RAM

IDT709379/69L

## Features

- ◆ True Dual-Ported memory cells which allow simultaneous access of the same memory location
- ◆ High-speed clock to data access
  - Commercial: 6.5/7.5/9/12ns (max.)
  - Industrial: 9ns (max.)
- ◆ Low-power operation
  - IDT709379/69L
  - Active: 1.2W (typ.)
  - Standby: 2.5mW (typ.)
- ◆ Flow-Through or Pipelined output mode on either Port via the  $\overline{\text{FT}}/\text{PIPE}$  pins
- ◆ Counter enable and reset features
- ◆ Dual chip enables allow for depth expansion without additional logic
- ◆ Full synchronous operation on both ports
  - 4ns setup to clock and 0ns hold on all control, data, and address inputs
  - Data input, address, and control registers
  - Fast 6.5ns clock to data out in the Pipelined output mode
  - Self-timed write allows fast cycle time
  - 10ns cycle time, 100MHz operation in Pipelined output mode
- ◆ Separate upper-byte and lower-byte controls for multiplexed bus and bus matching compatibility
- ◆ TTL-compatible, single 5V ( $\pm 10\%$ ) power supply
- ◆ Industrial temperature range ( $-40^{\circ}\text{C}$  to  $+85^{\circ}\text{C}$ ) is available for selected speeds
- ◆ Available in a 100-pin Thin Quad Flatpack (TQFP) package
- ◆ Green parts available, see ordering information

## Functional Block Diagram

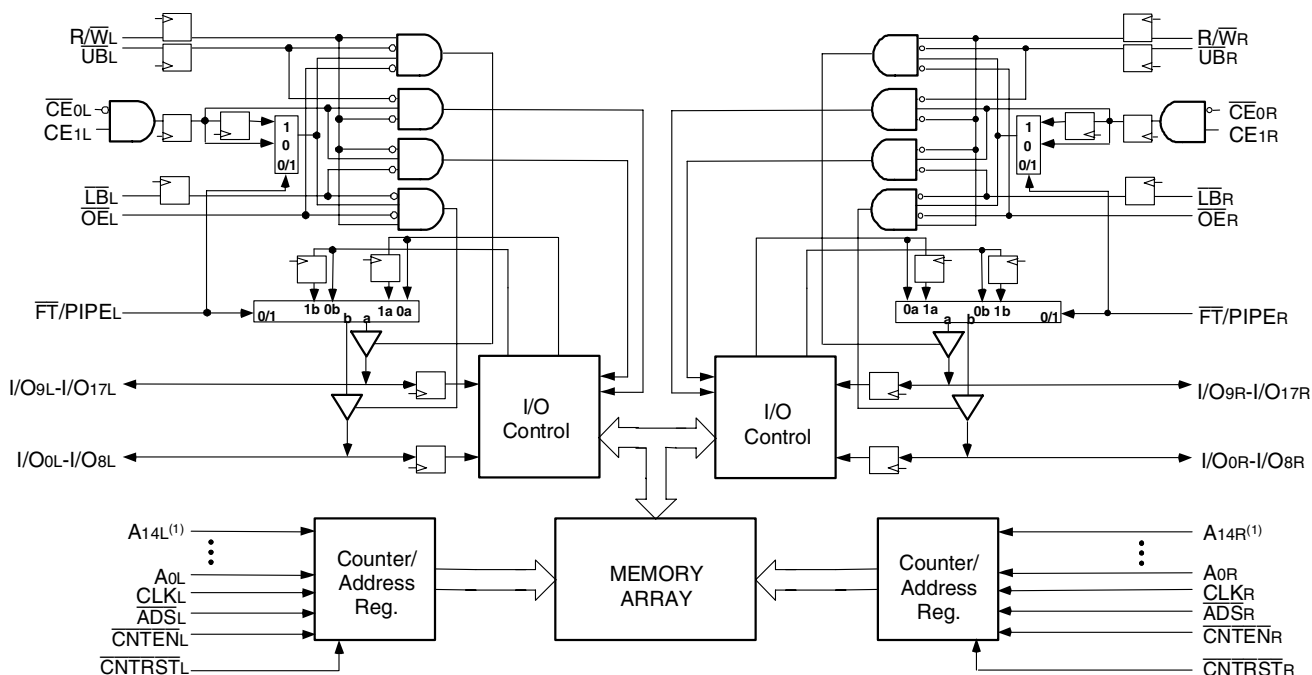

4845 drw 01

### NOTE:

1. A14x is a NC for IDT709369.

JULY 2010

## Description

The IDT709379/69 is a high-speed 32/16K x 18 bit synchronous Dual-Port RAM. The memory array utilizes Dual-Port memory cells to allow simultaneous access of any address from both ports. Registers on control, data, and address inputs provide minimal setup and hold times. The timing latitude provided by this approach allows systems to be designed with very short cycle times.

With an input data register, the IDT709379/69 has been optimized for applications having unidirectional or bidirectional data flow in bursts. An automatic power down feature, controlled by  $\overline{CE0}$  and  $CE1$ , permits the on-chip circuitry of each port to enter a very low standby power mode. Fabricated using IDT's CMOS high-performance technology, these devices typically operate on only 1.2W of power.

## Pin Configurations<sup>(1,2,3)</sup>

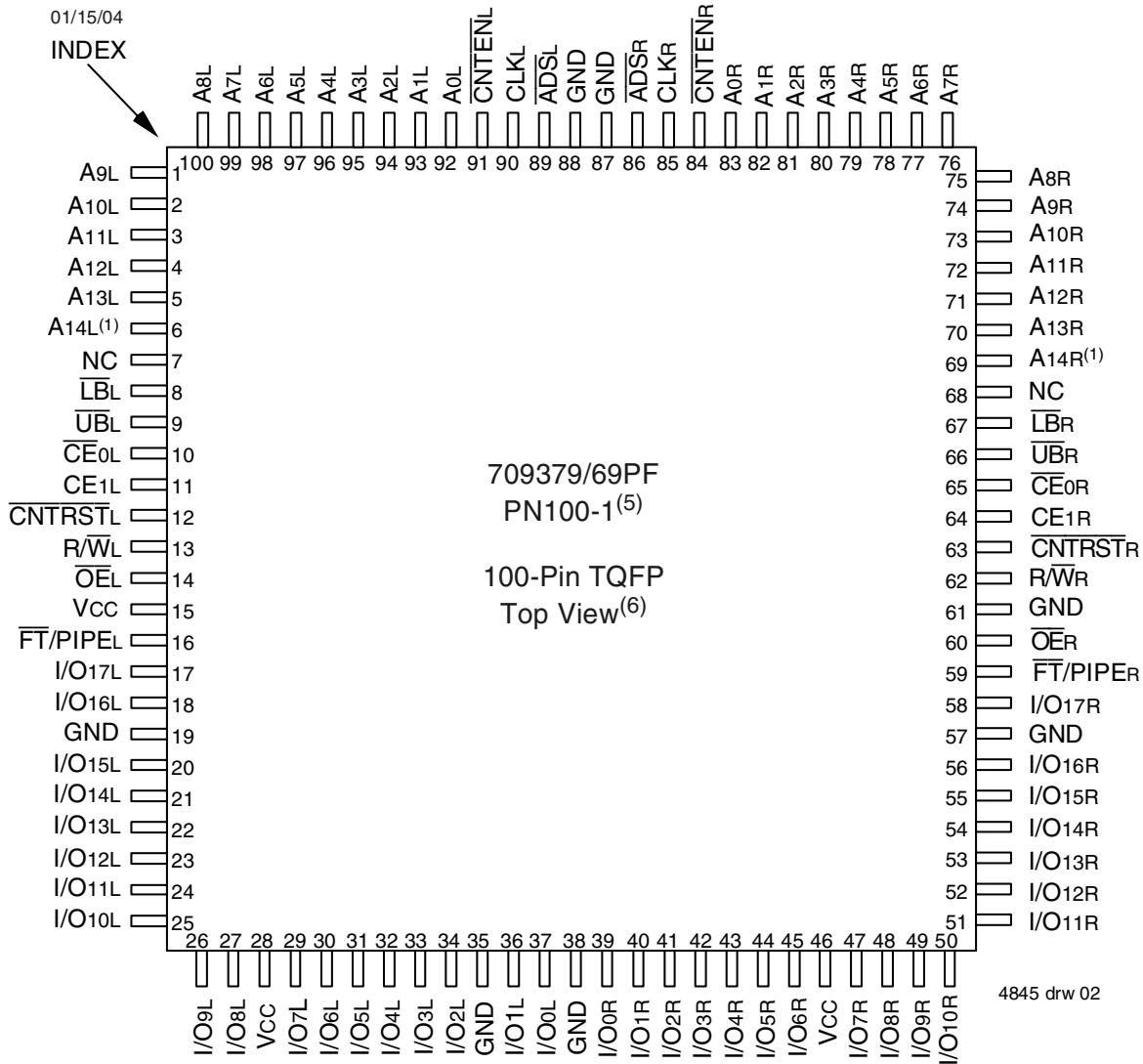

### NOTES:

1. A14x is a NC for IDT709369.
2. All Vcc pins must be connected to power supply.
3. All GND pins must be connected to ground.
4. Package body is approximately 14mm x 14mm x 1.4mm
5. This package code is used to reference the package diagram.
6. This text does not indicate orientation of the actual part-marking.

## Pin Names

| Left Port                     | Right Port                    | Names                            |
|-------------------------------|-------------------------------|----------------------------------|
| $\overline{CE}_{0L}, CE_{1L}$ | $\overline{CE}_{0R}, CE_{1R}$ | Chip Enables <sup>(3)</sup>      |
| $R/\overline{W}_L$            | $R/\overline{W}_R$            | Read/Write Enable                |
| $\overline{OE}_L$             | $\overline{OE}_R$             | Output Enable                    |
| $A_{0L} - A_{14L}^{(1)}$      | $A_{0R} - A_{14R}^{(1)}$      | Address                          |
| $I/O_{0L} - I/O_{17L}$        | $I/O_{0R} - I/O_{17R}$        | Data Input/Output                |
| CLKL                          | CLKR                          | Clock                            |
| $\overline{UB}_L$             | $\overline{UB}_R$             | Upper Byte Select <sup>(2)</sup> |
| $\overline{LB}_L$             | $\overline{LB}_R$             | Lower Byte Select <sup>(2)</sup> |
| $\overline{ADS}_L$            | $\overline{ADS}_R$            | Address Strobe                   |
| $\overline{CNTEN}_L$          | $\overline{CNTEN}_R$          | Counter Enable                   |
| $\overline{CNTRST}_L$         | $\overline{CNTRST}_R$         | Counter Reset                    |
| $\overline{FT}/PIPE_L$        | $\overline{FT}/PIPE_R$        | Flow-Through/Pipeline            |
| VCC                           |                               | Power                            |
| GND                           |                               | Ground                           |

4845 tbl 01

### NOTES:

1. A14x is a NC for IDT709369.
2.  $\overline{LB}$  and  $\overline{UB}$  are single buffered regardless of state of  $\overline{FT}/PIPE$ .
3.  $\overline{CE}_0$  and  $CE_1$  are single buffered when  $\overline{FT}/PIPE = V_{IL}$ ,  $\overline{CE}_0$  and  $CE_1$  are double buffered when  $\overline{FT}/PIPE = V_{IH}$ , i.e. the signals take two cycles to deselect.

## Truth Table I—Read/Write and Enable Control<sup>(1,2,3)</sup>

| $\overline{OE}$ | CLK | $\overline{CE}_0$ | $CE_1$ | $\overline{UB}$ | $\overline{LB}$ | $R/\overline{W}$ | Upper Byte<br>I/O <sub>9-17</sub> | Lower Byte<br>I/O <sub>0-8</sub> | Mode                     |
|-----------------|-----|-------------------|--------|-----------------|-----------------|------------------|-----------------------------------|----------------------------------|--------------------------|
| X               | ↑   | H                 | X      | X               | X               | X                | High-Z                            | High-Z                           | Deselected—Power Down    |
| X               | ↑   | X                 | L      | X               | X               | X                | High-Z                            | High-Z                           | Deselected—Power Down    |
| X               | ↑   | L                 | H      | H               | H               | X                | High-Z                            | High-Z                           | Both Bytes Deselected    |
| X               | ↑   | L                 | H      | L               | H               | L                | DATA <sub>IN</sub>                | High-Z                           | Write to Upper Byte Only |
| X               | ↑   | L                 | H      | H               | L               | L                | High-Z                            | DATA <sub>IN</sub>               | Write to Lower Byte Only |
| X               | ↑   | L                 | H      | L               | L               | L                | DATA <sub>IN</sub>                | DATA <sub>IN</sub>               | Write to Both Bytes      |
| L               | ↑   | L                 | H      | L               | H               | H                | DATA <sub>OUT</sub>               | High-Z                           | Read Upper Byte Only     |
| L               | ↑   | L                 | H      | H               | L               | H                | High-Z                            | DATA <sub>OUT</sub>              | Read Lower Byte Only     |
| L               | ↑   | L                 | H      | L               | L               | H                | DATA <sub>OUT</sub>               | DATA <sub>OUT</sub>              | Read Both Bytes          |
| H               | X   | L                 | H      | L               | L               | X                | High-Z                            | High-Z                           | Outputs Disabled         |

4845 tbl 02

### NOTES:

1. "H" =  $V_{IH}$ , "L" =  $V_{IL}$ , "X" = Don't Care.
2.  $\overline{ADS}$ ,  $\overline{CNTEN}$ ,  $\overline{CNTRST}$  = X.
3.  $\overline{OE}$  is an asynchronous input signal.

**Truth Table II—Address Counter Control<sup>(1,2,6)</sup>**

| External Address | Previous Internal Address | Internal Address Used | CLK | $\overline{ADS}$ | $\overline{CNTEN}$ | $\overline{CNTRST}$ | I/O <sup>(3)</sup>     | MODE  |
|------------------|---------------------------|-----------------------|-----|------------------|--------------------|---------------------|------------------------|---|
| An               | X                         | An                    | ↑   | L <sup>(4)</sup> | X                  | H                   | D <sub>I/O</sub> (n)   | External Address Used                                     |
| X                | An                        | An + 1                | ↑   | H                | L <sup>(5)</sup>   | H                   | D <sub>I/O</sub> (n+1) | Counter Enabled—Internal Address generation               |
| X                | An + 1                    | An + 1                | ↑   | H                | H                  | H                   | D <sub>I/O</sub> (n+1) | External Address Blocked—Counter disabled (An + 1 reused) |
| X                | X                         | A <sub>0</sub>        | ↑   | X                | X                  | L <sup>(4)</sup>    | D <sub>I/O</sub> (0)   | Counter Reset to Address 0                                |

4845 tbl 03

**NOTES:**

- "H" = V<sub>IH</sub>, "L" = V<sub>IL</sub>, "X" = Don't Care.
- $\overline{CE_0}$ ,  $\overline{LB}$ ,  $\overline{UB}$ , and  $\overline{OE}$  = V<sub>IL</sub>; CE<sub>1</sub> and R/W = V<sub>IH</sub>.
- Outputs configured in Flow-Through Output mode: if outputs are in Pipelined mode the data out will be delayed by one cycle.
- $\overline{ADS}$  is independent of all other signals including  $\overline{CE_0}$ , CE<sub>1</sub>,  $\overline{UB}$  and  $\overline{LB}$ .
- The address counter advances if  $\overline{CNTEN}$  = V<sub>IL</sub> on the rising edge of CLK, regardless of all other signals including  $\overline{CE_0}$ , CE<sub>1</sub>,  $\overline{UB}$  and  $\overline{LB}$ .
- While an external address is being loaded ( $\overline{ADS}$  = V<sub>IL</sub>), R/W = V<sub>IH</sub> is recommended to ensure data is not written arbitrarily.

**Recommended Operating Temperature and Supply Voltage**

| Grade      | Ambient Temperature <sup>(2)</sup> | GND | V <sub>CC</sub> |
|------------|------------------------------------|-----|-----------------|
| Commercial | 0°C to +70°C                       | 0V  | 5.0V ± 10%      |
| Industrial | -40°C to +85°C                     | 0V  | 5.0V ± 10%      |

4845 tbl 04

**NOTES:**

- This is the parameter T<sub>A</sub>. This is the "instant on" case temperature.

**Recommended DC Operating Conditions**

| Symbol          | Parameter          | Min.                | Typ. | Max.               | Unit |
|-----------------|--------------------|---------------------|------|--------------------|------|
| V <sub>CC</sub> | Supply Voltage     | 4.5                 | 5.0  | 5.5                | V    |
| GND             | Ground             | 0                   | 0    | 0                  | V    |
| V <sub>IH</sub> | Input High Voltage | 2.2                 | —    | 6.0 <sup>(1)</sup> | V    |
| V <sub>IL</sub> | Input Low Voltage  | -0.5 <sup>(2)</sup> | —    | 0.8                | V    |

4845 tbl 05

**NOTES:**

- V<sub>TERM</sub> must not exceed V<sub>CC</sub> + 10%.
- V<sub>IL</sub> ≥ -1.5V for pulse width less than 10ns.

**Absolute Maximum Ratings<sup>(1)</sup>**

| Symbol                           | Rating                               | Commercial & Industrial | Unit |
|----------------------------------|--------------------------------------|-------------------------|------|
| V <sub>TERM</sub> <sup>(2)</sup> | Terminal Voltage with Respect to GND | -0.5 to +7.0            | V    |
| T <sub>BIAS</sub>                | Temperature Under Bias               | -55 to +125             | °C   |
| T <sub>STG</sub>                 | Storage Temperature                  | -65 to +150             | °C   |
| T <sub>JN</sub>                  | Junction Temperature                 | +150                    | °C   |
| I <sub>OUT</sub>                 | DC Output Current                    | 50                      | mA   |

4845 tbl 06

**NOTES:**

- Stresses greater than those listed under ABSOLUTE MAXIMUM RATINGS may cause permanent damage to the device. This is a stress rating only and functional operation of the device at these or any other conditions above those indicated in the operational sections of this specification is not implied. Exposure to absolute maximum rating conditions for extended periods may affect reliability.
- V<sub>TERM</sub> must not exceed V<sub>CC</sub> + 10% for more than 25% of the cycle time or 10ns maximum, and is limited to ≤ 20mA for the period of V<sub>TERM</sub> ≥ V<sub>CC</sub> + 10%.
- Ambient Temperature Under Bias. No AC Conditions. Chip Deselected.

**Capacitance<sup>(1)</sup>**(T<sub>A</sub> = +25°C, f = 1.0MHz)

| Symbol                          | Parameter          | Conditions <sup>(2)</sup> | Max. | Unit |
|---------------------------------|--------------------|---------------------------|------|------|
| C <sub>IN</sub>                 | Input Capacitance  | V <sub>IN</sub> = 3dV     | 9    | pF   |
| C <sub>OUT</sub> <sup>(3)</sup> | Output Capacitance | V <sub>OUT</sub> = 3dV    | 10   | pF   |

4845 tbl 07

**NOTES:**

- These parameters are determined by device characterization, but are not production tested.
- 3dV references the interpolated capacitance when the input and output switch from 0V to 3V or from 3V to 0V.
- C<sub>OUT</sub> also references C<sub>I/O</sub>.

## DC Electrical Characteristics Over the Operating Temperature Supply Voltage Range ( $V_{CC} = 5.0V \pm 10\%$ )

| Symbol          | Parameter                            | Test Conditions   | 709379/69L |      | Unit    |
|-----------------|--------------------------------------|---|------------|------|---------|
|                 |                                      |   | Min.       | Max. |         |
| II <sub>L</sub> | Input Leakage Current <sup>(1)</sup> | $V_{CC} = 5.5V, V_{IN} = 0V \text{ to } V_{CC}$                                       | —          | 5    | $\mu A$ |
| II <sub>O</sub> | Output Leakage Current               | $\overline{CE}_0 = V_{IH} \text{ or } CE_1 = V_{IL}, V_{OUT} = 0V \text{ to } V_{CC}$ | —          | 5    | $\mu A$ |
| V <sub>OL</sub> | Output Low Voltage                   | I <sub>OL</sub> = +4mA  | —          | 0.4  | V       |
| V <sub>OH</sub> | Output High Voltage                  | I <sub>OH</sub> = -4mA  | 2.4        | —    | V       |

4845 tbl 08

**NOTE:**

- At  $V_{CC} \leq 2.0V$  input leakages are undefined.

## DC Electrical Characteristics Over the Operating Temperature and Supply Voltage Range<sup>(3)</sup> ( $V_{CC} = 5V \pm 10\%$ )

| Symbol           | Parameter   | Test Condition   | Version | 709379/69L6<br>Com'l Only |      | 709379/69L7<br>Com'l Only |      | 709379/69L9<br>Com'l<br>& Ind |      | 709379/69L12<br>Com'l Only |      | Unit |    |
|------------------|---|--|---------|---------------------------|------|---------------------------|------|-------------------------------|------|----------------------------|------|------|----|
|                  |   |  |         | Typ. <sup>(4)</sup>       | Max. | Typ. <sup>(4)</sup>       | Max. | Typ. <sup>(4)</sup>           | Max. | Typ. <sup>(4)</sup>        | Max. |      |    |
| I <sub>CC</sub>  | Dynamic Operating Current<br>(Both Ports Active)            | $\overline{CE}_L \text{ and } \overline{CE}_R = V_{IL}$<br>Outputs Disabled<br>$f = f_{MAX}^{(1)}$   | COM'L   | L                         | 270  | 525                       | 250  | 440                           | 250  | 400                        | 230  | 355  | mA |
|                  |   |  | IND     | L                         | —    | —                         | —    | —                             | 300  | 430                        | —    | —    |    |
| I <sub>SB1</sub> | Standby Current<br>(Both Ports - TTL<br>Level Inputs)       | $\overline{CE}_L = \overline{CE}_R = V_{IH}$<br>$f = f_{MAX}^{(1)}$  | COM'L   | L                         | 80   | 175                       | 65   | 145                           | 80   | 135                        | 70   | 110  | mA |
|                  |   |  | IND     | L                         | —    | —                         | —    | —                             | 95   | 160                        | —    | —    |    |
| I <sub>SB2</sub> | Standby Current<br>(One Port - TTL<br>Level Inputs)         | $\overline{CE}^*A = V_{IL}$ and<br>$\overline{CE}^*B = V_{IH}^{(3)}$<br>Active Port Outputs<br>Disabled, $f = f_{MAX}^{(1)}$   | COM'L   | L                         | 180  | 360                       | 160  | 295                           | 175  | 275                        | 150  | 240  | mA |
|                  |   |  | IND     | L                         | —    | —                         | —    | —                             | 175  | 295                        | —    | —    |    |
| I <sub>SB3</sub> | Full Standby Current<br>(Both Ports -<br>CMOS Level Inputs) | Both Ports $\overline{CE}_R$ and<br>$\overline{CE}_L \geq V_{CC} - 0.2V$<br>$V_{IN} \geq V_{CC} - 0.2V$ or<br>$V_{IN} \leq 0.2V, f = 0^{(2)}$  | COM'L   | L                         | 0.2  | 5                         | 0.2  | 5.0                           | 0.5  | 3.0                        | 0.5  | 3.0  | mA |
|                  |   |  | IND     | L                         | —    | —                         | —    | —                             | 0.5  | 6.0                        | —    | —    |    |
| I <sub>SB4</sub> | Full Standby Current<br>(One Port -<br>CMOS Level Inputs)   | $\overline{CE}^*A \leq 0.2V$ and<br>$\overline{CE}^*B \geq V_{CC} - 0.2V^{(5)}$<br>$V_{IN} \geq V_{CC} - 0.2V$ or<br>$V_{IN} \leq 0.2V$ , Active Port<br>Outputs Disabled, $f = f_{MAX}^{(1)}$ | COM'L   | L                         | 170  | 340                       | 150  | 290                           | 170  | 270                        | 140  | 225  | mA |
|                  |   |  | IND     | L                         | —    | —                         | —    | —                             | 190  | 290                        | —    | —    |    |

4845 tbl 09

**NOTES:**

- At  $f = f_{MAX}$ , address and control lines (except Output Enable) are cycling at the maximum frequency clock cycle of  $1/t_{cyc}$ , using "AC TEST CONDITIONS" at input levels of GND to 3V.
- $f = 0$  means no address, clock, or control lines change. Applies only to input at CMOS level standby.
- Port "A" may be either left or right port. Port "B" is the opposite from port "A".
- $V_{CC} = 5V, T_A = 25^\circ C$  for Typ, and are not production tested.  $I_{CC} DC(f=0) = 150mA$  (Typ).
- $\overline{CE}_X = V_{IL}$  means  $\overline{CE}_{0X} = V_{IL}$  and  $\overline{CE}_{1X} = V_{IH}$   
 $\overline{CE}_X = V_{IH}$  means  $\overline{CE}_{0X} = V_{IH}$  or  $\overline{CE}_{1X} = V_{IL}$   
 $\overline{CE}_X \leq 0.2V$  means  $\overline{CE}_{0X} \leq 0.2V$  and  $\overline{CE}_{1X} \geq V_{CC} - 0.2V$   
 $\overline{CE}_X \geq V_{CC} - 0.2V$  means  $\overline{CE}_{0X} \geq V_{CC} - 0.2V$  or  $\overline{CE}_{1X} \leq 0.2V$   
"X" represents "L" for left port or "R" for right port.

### AC Test Conditions

|                               |                   |
|-------------------------------|-------------------|
| Input Pulse Levels            | GND to 3.0V       |
| Input Rise/Fall Times         | 3ns Max.          |
| Input Timing Reference Levels | 1.5V              |
| Output Reference Levels       | 1.5V              |
| Output Load                   | Figures 1,2 and 3 |

4845 tbl 10

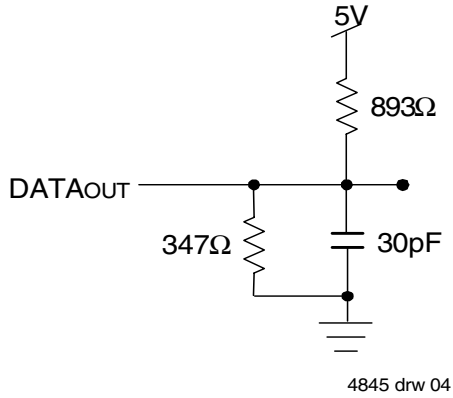

Figure 1. AC Output Test load.

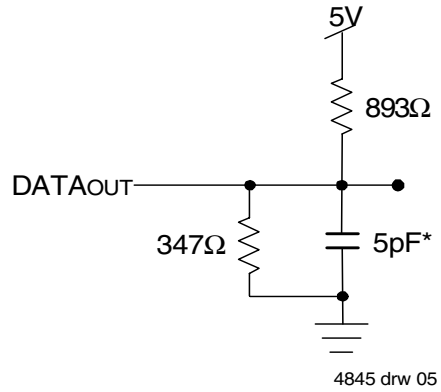

Figure 2. Output Test Load  
(For t<sub>CKLZ</sub>, t<sub>CKHZ</sub>, t<sub>OLZ</sub>, and t<sub>OHZ</sub>).  
\*Including scope and jig.

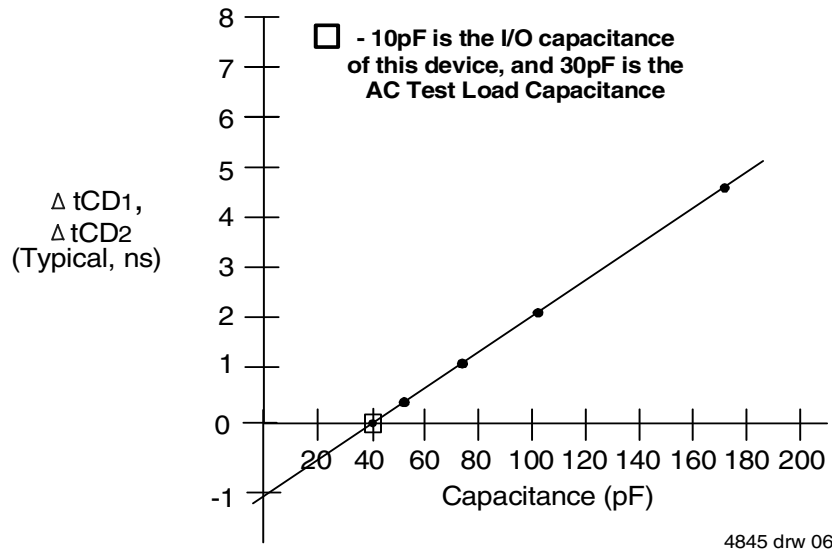

Figure 3. Typical Output Derating (Lumped Capacitive Load).

## AC Electrical Characteristics Over the Operating Temperature Range (Read and Write Cycle Timing)<sup>(3)</sup> (V<sub>CC</sub> = 5V ± 10%)

| Symbol                    | Parameter   | 709379/69L6<br>Com'l Only |      | 709379/69L7<br>Com'l Only |      | 709379/69L9<br>Com'l & Ind |      | 709379/69L12<br>Com'l Only |      | Unit |
|---------------------------|---|---------------------------|------|---------------------------|------|----------------------------|------|----------------------------|------|------|
|                           |   | Min.                      | Max. | Min.                      | Max. | Min.                       | Max. | Min.                       | Max. |      |
| t <sub>CYC1</sub>         | Clock Cycle Time (Flow-Through) <sup>(2)</sup>    | 19                        | —    | 22                        | —    | 25                         | —    | 30                         | —    | ns   |
| t <sub>CYC2</sub>         | Clock Cycle Time (Pipelined) <sup>(2)</sup>       | 10                        | —    | 12                        | —    | 15                         | —    | 20                         | —    | ns   |
| t <sub>CH1</sub>          | Clock High Time (Flow-Through) <sup>(2)</sup>     | 6.5                       | —    | 7.5                       | —    | 12                         | —    | 12                         | —    | ns   |
| t <sub>CL1</sub>          | Clock Low Time (Flow-Through) <sup>(2)</sup>      | 6.5                       | —    | 7.5                       | —    | 12                         | —    | 12                         | —    | ns   |
| t <sub>CH2</sub>          | Clock High Time (Pipelined) <sup>(2)</sup>        | 4                         | —    | 5                         | —    | 6                          | —    | 8                          | —    | ns   |
| t <sub>CL2</sub>          | Clock Low Time (Pipelined) <sup>(2)</sup>         | 4                         | —    | 5                         | —    | 6                          | —    | 8                          | —    | ns   |
| t <sub>R</sub>            | Clock Rise Time                                   | —                         | 3    | —                         | 3    | —                          | 3    | —                          | 3    | ns   |
| t <sub>F</sub>            | Clock Fall Time                                   | —                         | 3    | —                         | 3    | —                          | 3    | —                          | 3    | ns   |
| t <sub>SA</sub>           | Address Setup Time                                | 3.5                       | —    | 4                         | —    | 4                          | —    | 4                          | —    | ns   |
| t <sub>HA</sub>           | Address Hold Time                                 | 0                         | —    | 0                         | —    | 1                          | —    | 1                          | —    | ns   |
| t <sub>SC</sub>           | Chip Enable Setup Time                            | 3.5                       | —    | 4                         | —    | 4                          | —    | 4                          | —    | ns   |
| t <sub>HC</sub>           | Chip Enable Hold Time                             | 0                         | —    | 0                         | —    | 1                          | —    | 1                          | —    | ns   |
| t <sub>SB</sub>           | Byte Enable Setup Time                            | 3.5                       | —    | 4                         | —    | 4                          | —    | 4                          | —    | ns   |
| t <sub>HB</sub>           | Byte Enable Hold Time                             | 0                         | —    | 0                         | —    | 1                          | —    | 1                          | —    | ns   |
| t <sub>SW</sub>           | R/W Setup Time                                    | 3.5                       | —    | 4                         | —    | 4                          | —    | 4                          | —    | ns   |
| t <sub>HW</sub>           | R/W Hold Time                                     | 0                         | —    | 0                         | —    | 1                          | —    | 1                          | —    | ns   |
| t <sub>SD</sub>           | Input Data Setup Time                             | 3.5                       | —    | 4                         | —    | 4                          | —    | 4                          | —    | ns   |
| t <sub>HD</sub>           | Input Data Hold Time                              | 0                         | —    | 0                         | —    | 1                          | —    | 1                          | —    | ns   |
| t <sub>SAD</sub>          | $\overline{ADS}$ Setup Time                       | 3.5                       | —    | 4                         | —    | 4                          | —    | 4                          | —    | ns   |
| t <sub>HAD</sub>          | $\overline{ADS}$ Hold Time                        | 0                         | —    | 0                         | —    | 1                          | —    | 1                          | —    | ns   |
| t <sub>SCN</sub>          | $\overline{CNTEN}$ Setup Time                     | 3.5                       | —    | 4                         | —    | 4                          | —    | 4                          | —    | ns   |
| t <sub>HCN</sub>          | $\overline{CNTEN}$ Hold Time                      | 0                         | —    | 0                         | —    | 1                          | —    | 1                          | —    | ns   |
| t <sub>SRST</sub>         | $\overline{CNTRST}$ Setup Time                    | 3.5                       | —    | 4                         | —    | 4                          | —    | 4                          | —    | ns   |
| t <sub>HRST</sub>         | $\overline{CNTRST}$ Hold Time                     | 0                         | —    | 0                         | —    | 1                          | —    | 1                          | —    | ns   |
| t <sub>OE</sub>           | Output Enable to Data Valid                       | —                         | 6.5  | —                         | 7.5  | —                          | 9    | —                          | 12   | ns   |
| t <sub>OLZ</sub>          | Output Enable to Output Low-Z <sup>(1)</sup>      | 2                         | —    | 2                         | —    | 2                          | —    | 2                          | —    | ns   |
| t <sub>OZH</sub>          | Output Enable to Output High-Z <sup>(1)</sup>     | 1                         | 7    | 1                         | 7    | 1                          | 7    | 1                          | 7    | ns   |
| t <sub>CD1</sub>          | Clock to Data Valid (Flow-Through) <sup>(2)</sup> | —                         | 15   | —                         | 18   | —                          | 20   | —                          | 25   | ns   |
| t <sub>CD2</sub>          | Clock to Data Valid (Pipelined) <sup>(2)</sup>    | —                         | 6.5  | —                         | 7.5  | —                          | 9    | —                          | 12   | ns   |
| t <sub>DC</sub>           | Data Output Hold After Clock High                 | 2                         | —    | 2                         | —    | 2                          | —    | 2                          | —    | ns   |
| t <sub>CKHZ</sub>         | Clock High to Output High-Z <sup>(1)</sup>        | 2                         | 9    | 2                         | 9    | 2                          | 9    | 2                          | 9    | ns   |
| t <sub>CKLZ</sub>         | Clock High to Output Low-Z <sup>(1)</sup>         | 2                         | —    | 2                         | —    | 2                          | —    | 2                          | —    | ns   |
| <b>Port-to-Port Delay</b> |   |                           |      |                           |      |                            |      |                            |      |      |
| t <sub>CWDD</sub>         | Write Port Clock High to Read Data Delay          | —                         | 24   | —                         | 28   | —                          | 35   | —                          | 40   | ns   |
| t <sub>CCS</sub>          | Clock-to-Clock Setup Time                         | —                         | 9    | —                         | 10   | —                          | 15   | —                          | 15   | ns   |

**NOTES:**

4845 tbl 11

1. Transition is measured 0mV from Low or High-impedance voltage with the Output Test Load (Figure 2). This parameter is guaranteed by device characterization, but is not production tested.
2. The Pipelined output parameters (t<sub>CYC2</sub>, t<sub>CD2</sub>) to either the Left or Right ports when  $\overline{FT}/PIPE = V_{IH}$ . Flow-Through parameters (t<sub>CYC1</sub>, t<sub>CD1</sub>) apply when  $\overline{FT}/PIPE = V_{IL}$  for that port.
3. All input signals are synchronous with respect to the clock except for the asynchronous Output Enable ( $\overline{OE}$ ),  $\overline{FT}/PIPE_R$  and  $\overline{FT}/PIPE_L$ .

### Timing Waveform of Read Cycle for Flow-Through Output ( $\overline{FT}/PIPE"X" = V_{IL}$ )<sup>(3,7)</sup>

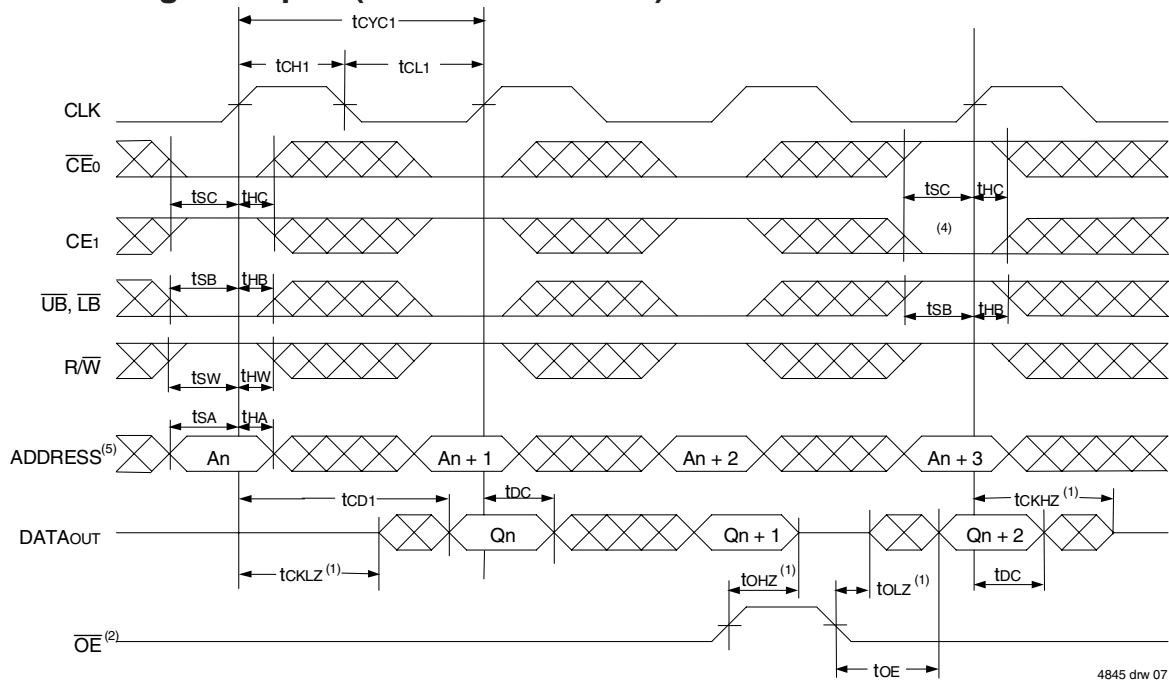

4845 drw 07

### Timing Waveform of Read Cycle for Pipelined Operation ( $\overline{FT}/PIPE"X" = V_{IH}$ )<sup>(3,7)</sup>

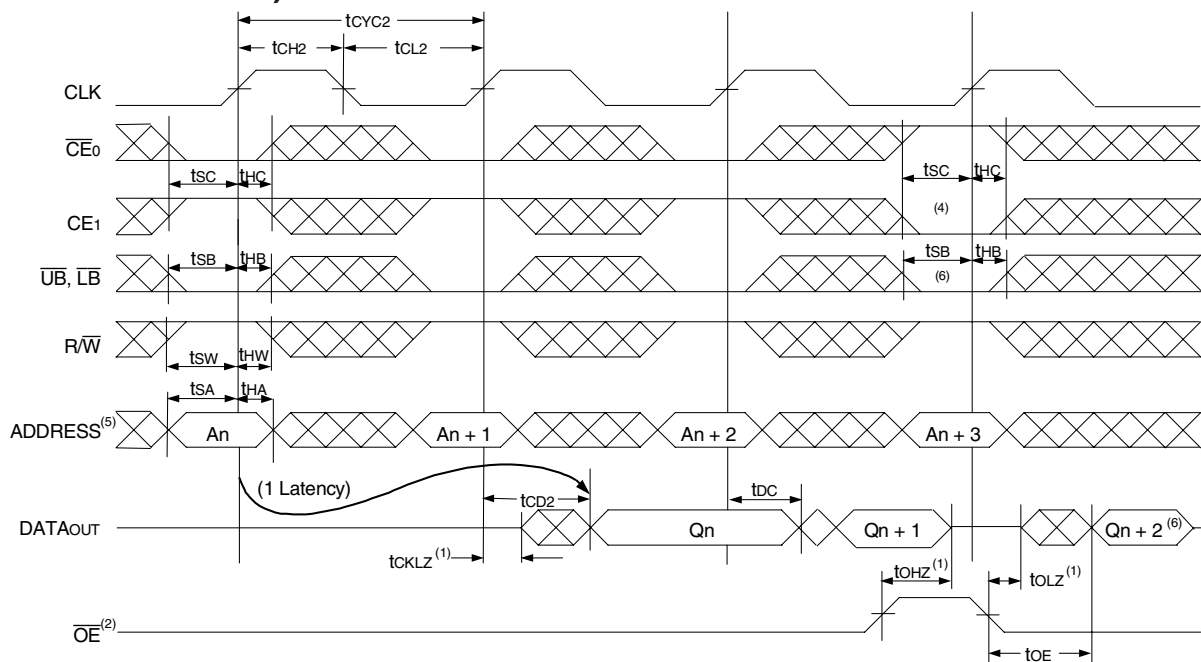

4845 drw 08

**NOTES:**

1. Transition is measured 0mV from Low or High-impedance voltage with the Output Test Load (Figure 2).
2.  $\overline{OE}$  is asynchronously controlled; all other inputs are synchronous to the rising clock edge.
3.  $\overline{ADS} = V_{IL}$  and  $\overline{CNTRST} = V_{IH}$ .
4. The output is disabled (High-Impedance state) by  $\overline{CE0} = V_{IH}$ ,  $CE1 = V_{IL}$ ,  $\overline{UB} = V_{IH}$ , or  $\overline{LB} = V_{IH}$  following the next rising edge of the clock. Refer to Truth Table 1.
5. Addresses do not have to be accessed sequentially since  $\overline{ADS} = V_{IL}$  constantly loads the address on the rising edge of the CLK; numbers are for reference use only.
6. If  $\overline{UB}$  or  $\overline{LB}$  was HIGH, then the Upper Byte and/or Lower Byte of DATAout for  $Q_{n+2}$  would be disabled (High-Impedance state).
7. "X" here denotes Left or Right port. The diagram is with respect to that port.

### Timing Waveform of a Bank Select Pipelined Read<sup>(1,2)</sup>

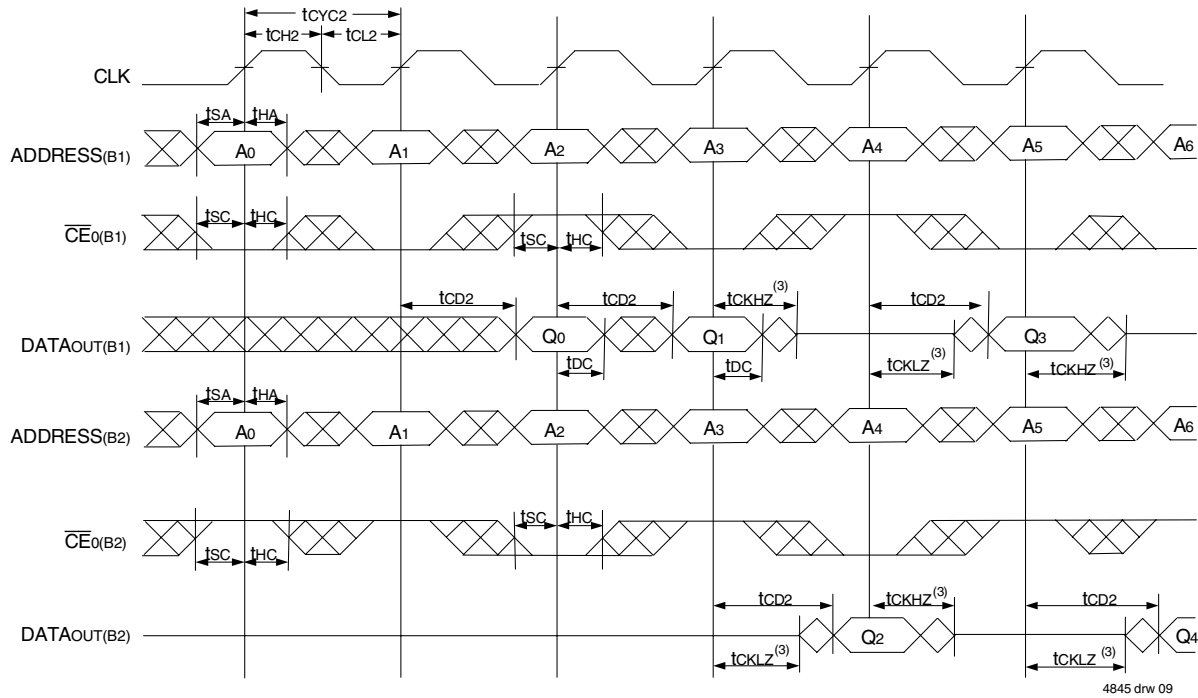

4845 drw 09

### Timing Waveform of Write with Port-to-Port Flow-Through Read<sup>(4,5,7)</sup>

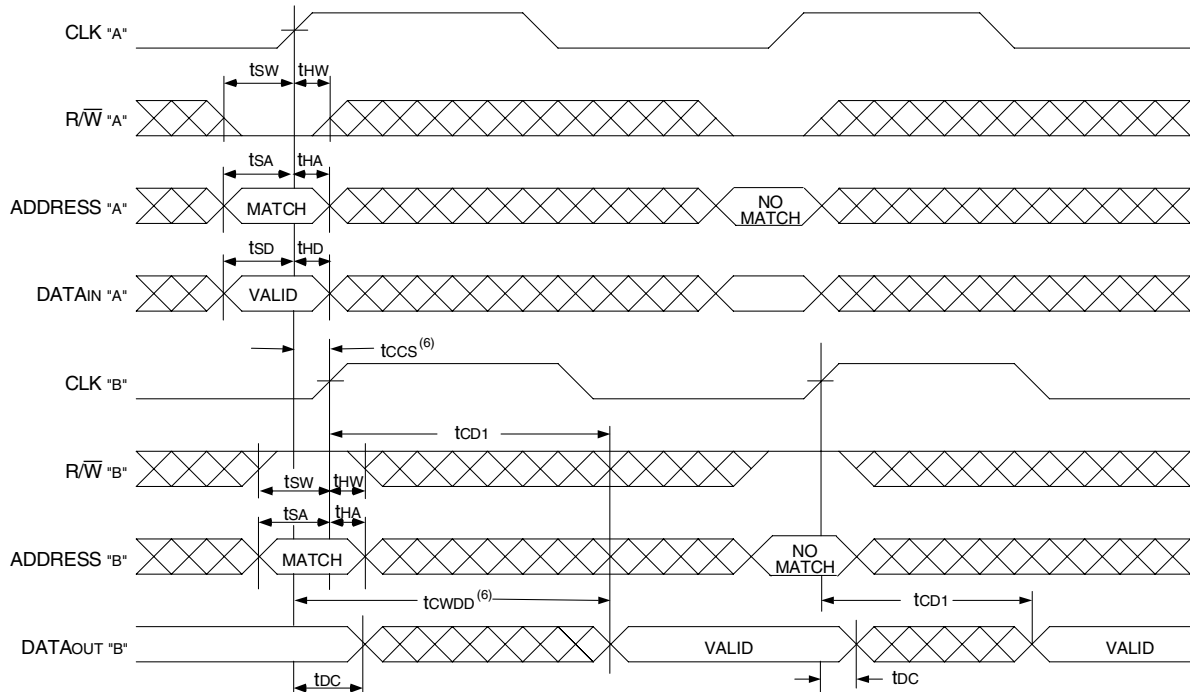

4845 drw 10

**NOTES:**

- B1 Represents Bank #1; B2 Represents Bank #2. Each Bank consists of one IDT709379/69 for this waveform, and are setup for depth expansion in this example. ADDRESS(B1) = ADDRESS(B2) in this situation.
- $\overline{UB}$ ,  $\overline{LB}$ ,  $\overline{OE}$ , and  $\overline{ADS} = V_{IL}$ ;  $CE_{1(B1)}$ ,  $CE_{1(B2)}$ ,  $R/\overline{W}$  and  $\overline{CNTRST} = V_{IH}$ .
- Transition is measured 0mV from Low or High-impedance voltage with the Output Test Load (Figure 2).
- $\overline{CE}_0$ ,  $\overline{UB}$ ,  $\overline{LB}$ , and  $\overline{ADS} = V_{IL}$ ;  $CE_1$  and  $\overline{CNTRST} = V_{IH}$ .
- $\overline{OE} = V_{IL}$  for the Right Port, which is being read from.  $\overline{OE} = V_{IH}$  for the Left Port, which is being written to.
- If  $t_{CCS} \leq$  maximum specified, then data from right port READ is not valid until the maximum specified for  $t_{CWDD}$ . If  $t_{CCS} >$  maximum specified, then data from right port READ is not valid until  $t_{CCS} + t_{CD1}$ .  $t_{CWDD}$  does not apply in this case.
- All timing is the same for both Left and Right ports. Port "A" may be either Left or Right port. Port "B" is the opposite from Port "A".

### Timing Waveform of Pipelined Read-to-Write-to-Read ( $\overline{OE} = V_{IL}$ )<sup>(3)</sup>

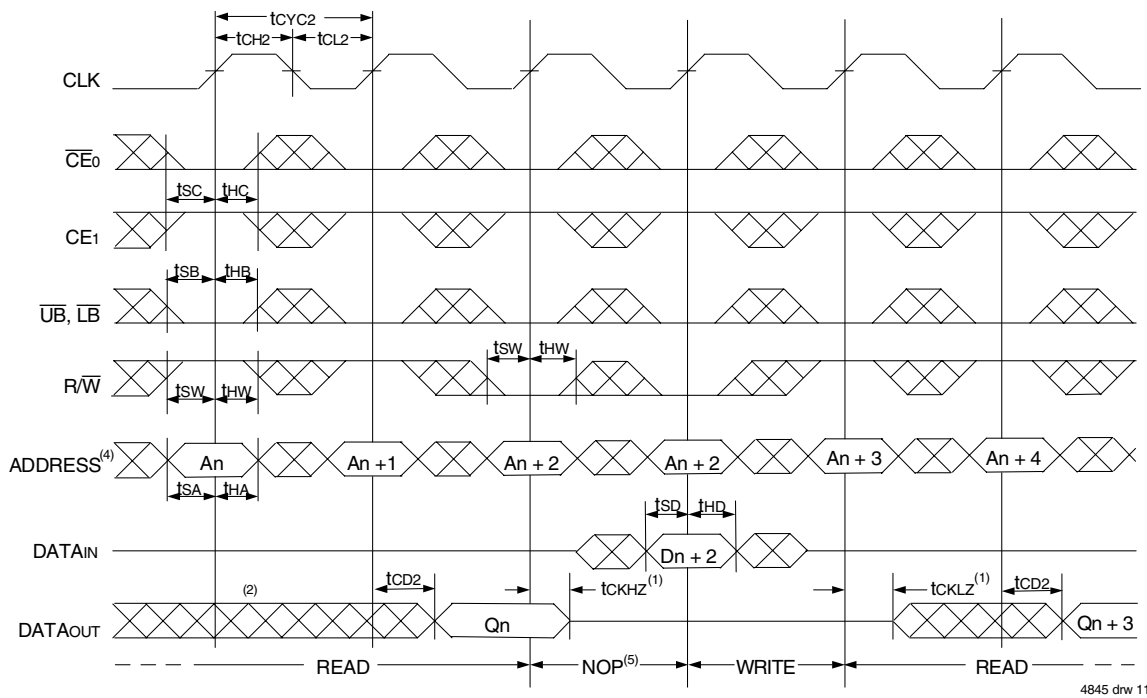

### Timing Waveform of Pipelined Read-to-Write-to-Read ( $\overline{OE}$ Controlled)<sup>(3)</sup>

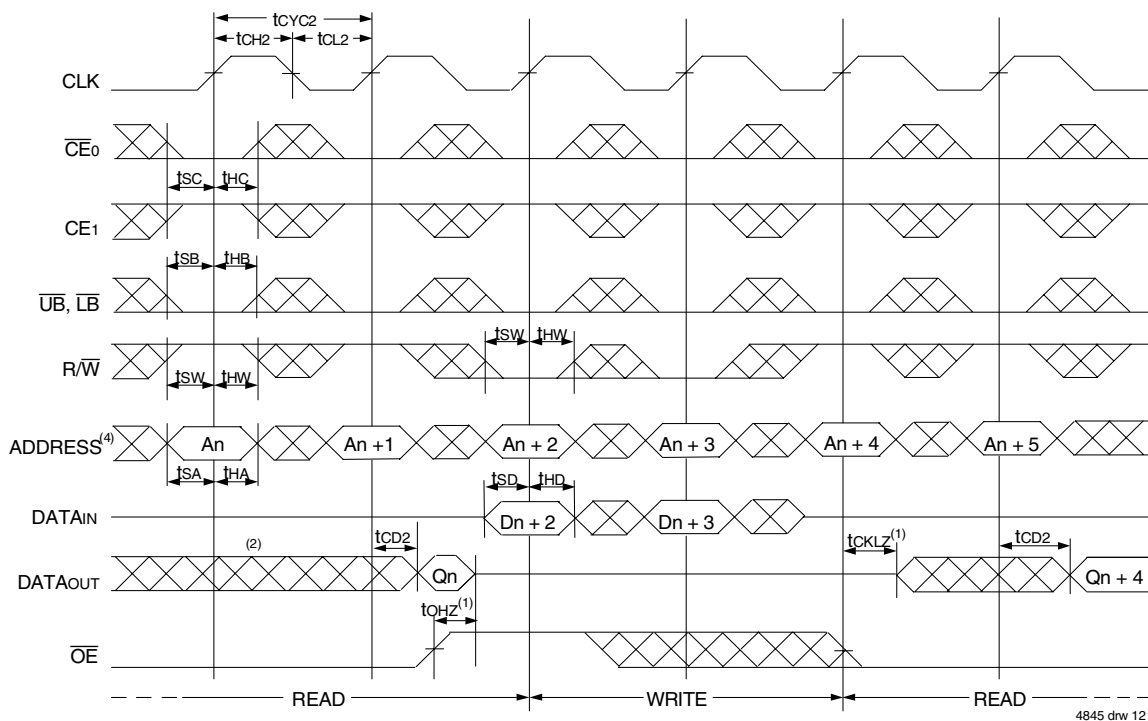

**NOTES:**

1. Transition is measured 0mV from Low or High-impedance voltage with the Output Test Load (Figure 2).
2. Output state (High, Low, or High-impedance) is determined by the previous cycle control signals.
3.  $\overline{CE0}$ ,  $\overline{UB}$ ,  $\overline{LB}$ , and  $\overline{ADS} = V_{IL}$ ;  $CE1$  and  $\overline{CNTRST} = V_{IH}$ . "NOP" is "No Operation".
4. Addresses do not have to be accessed sequentially since  $\overline{ADS} = V_{IL}$  constantly loads the address on the rising edge of the CLK; numbers are for reference use only.
5. "NOP" is "No Operation." Data in memory at the selected address may be corrupted and should be re-written to guarantee data integrity.

### Timing Waveform of Flow-Through Read-to-Write-to-Read ( $\overline{OE} = V_{IL}$ )<sup>(3)</sup>

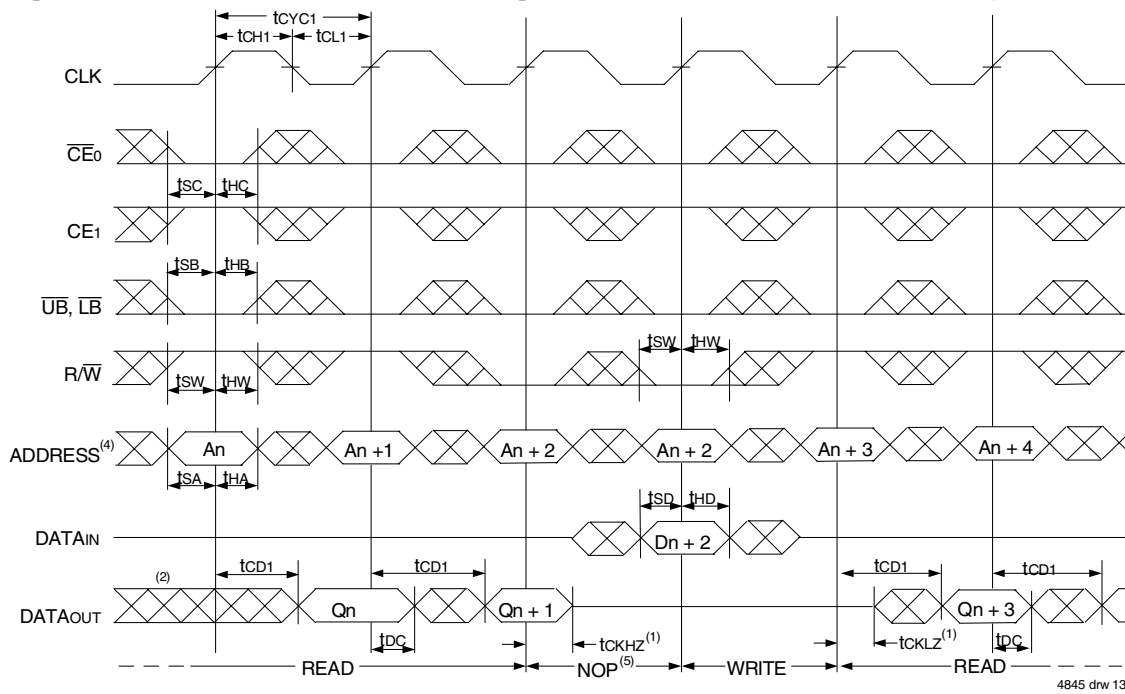

### Timing Waveform of Flow-Through Read-to-Write-to-Read ( $\overline{OE}$ Controlled)<sup>(3)</sup>

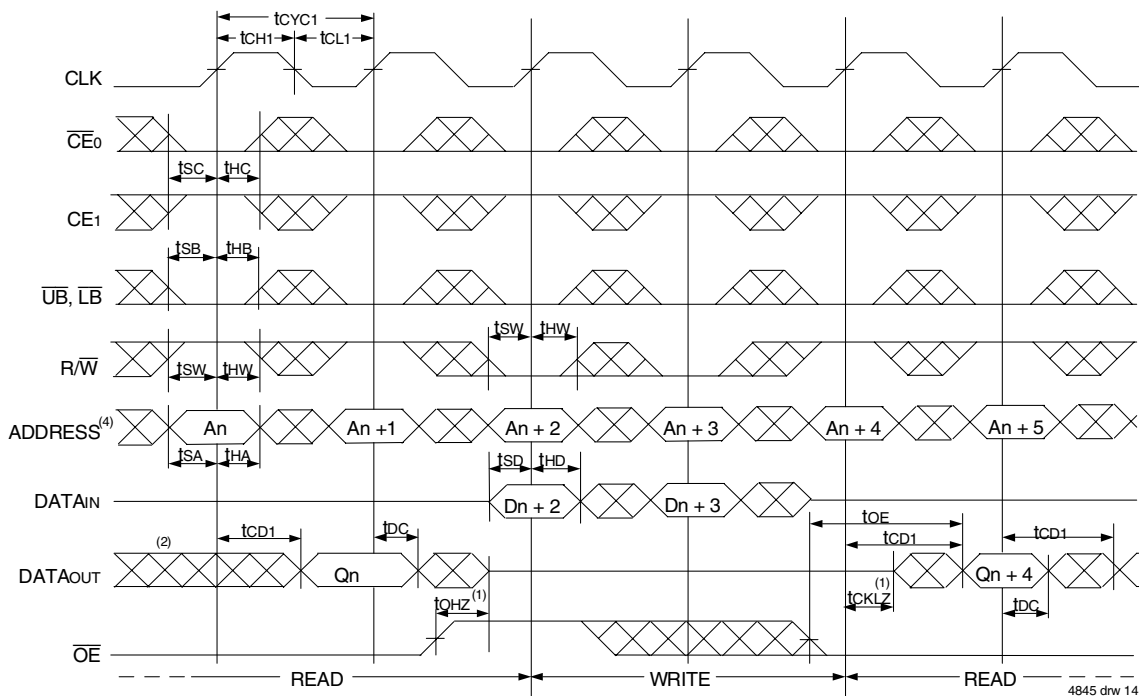

**NOTES:**

1. Transition is measured 0mV from Low or High-impedance voltage with the Output Test Load (Figure 2).
2. Output state (High, Low, or High-impedance) is determined by the previous cycle control signals.
3.  $\overline{CE0}$ ,  $\overline{UB}$ ,  $\overline{LB}$ , and  $\overline{ADS} = V_{IL}$ ;  $CE1$  and  $\overline{CNTRST} = V_{IH}$ . "NOP" is "No Operation".
4. Addresses do not have to be accessed sequentially since  $\overline{ADS} = V_{IL}$  constantly loads the address on the rising edge of the CLK; numbers are for reference use only.
5. "NOP" is "No Operation." Data in memory at the selected address may be corrupted and should be re-written to guarantee data integrity.

### Timing Waveform of Pipelined Read with Address Counter Advance<sup>(1)</sup>

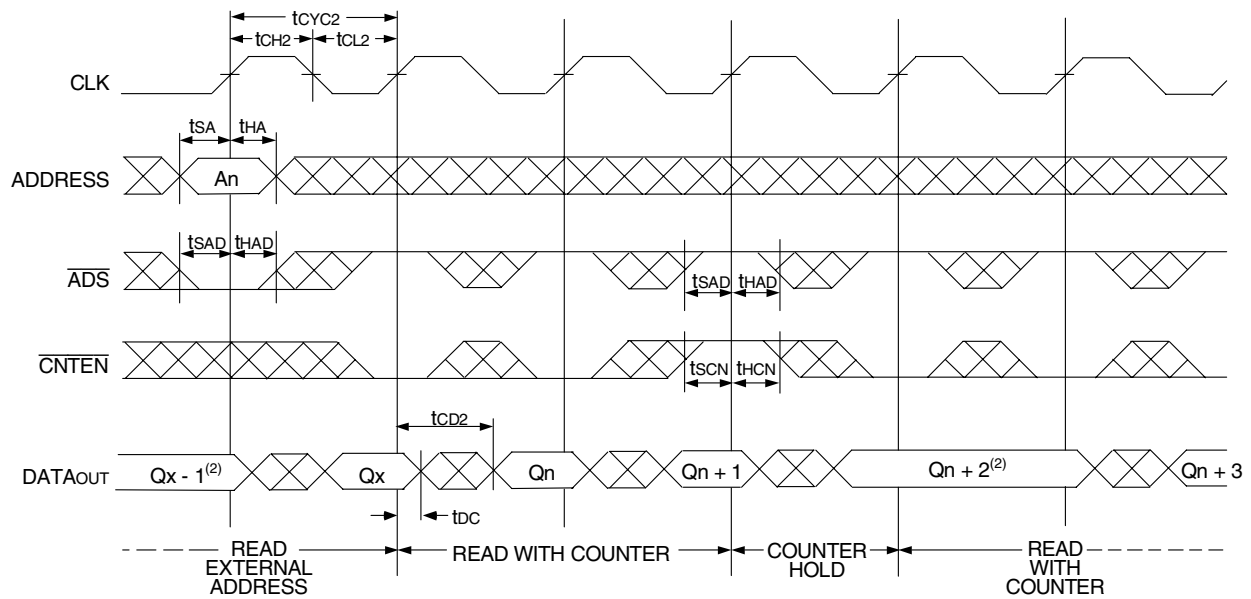

4845 drw 15

### Timing Waveform of Flow-Through Read with Address Counter Advance<sup>(1)</sup>

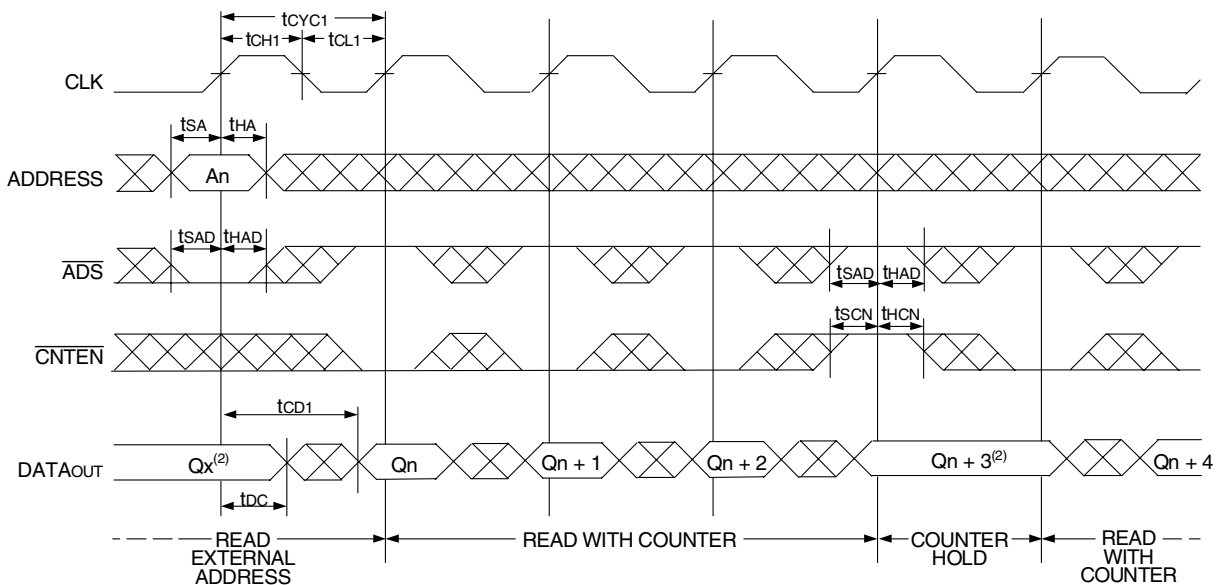

4845 drw 16

**NOTES:**

1.  $\overline{CE}_0$ ,  $\overline{OE}$ ,  $\overline{UB}$ , and  $\overline{LB} = V_{IL}$ ;  $CE_1$ ,  $R/\overline{W}$ , and  $\overline{CNTRST} = V_{IH}$ .
2. If there is no address change via  $\overline{ADS} = V_{IL}$  (loading a new address) or  $\overline{CNTEN} = V_{IL}$  (advancing the address), i.e.  $\overline{ADS} = V_{IH}$  and  $\overline{CNTEN} = V_{IH}$ , then the data output remains constant for subsequent clocks.

## Timing Waveform of Write with Address Counter Advance (Flow-Through or Pipelined Outputs)<sup>(1)</sup>

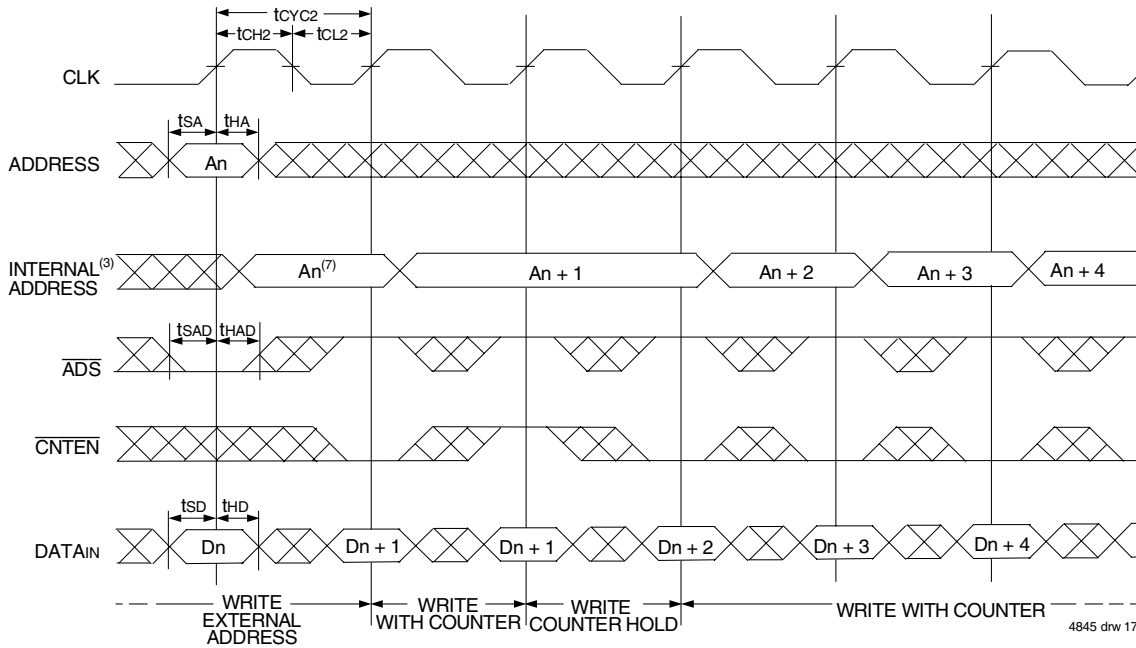

4845 drw 17

## Timing Waveform of Counter Reset (Pipelined Outputs)<sup>(2)</sup>

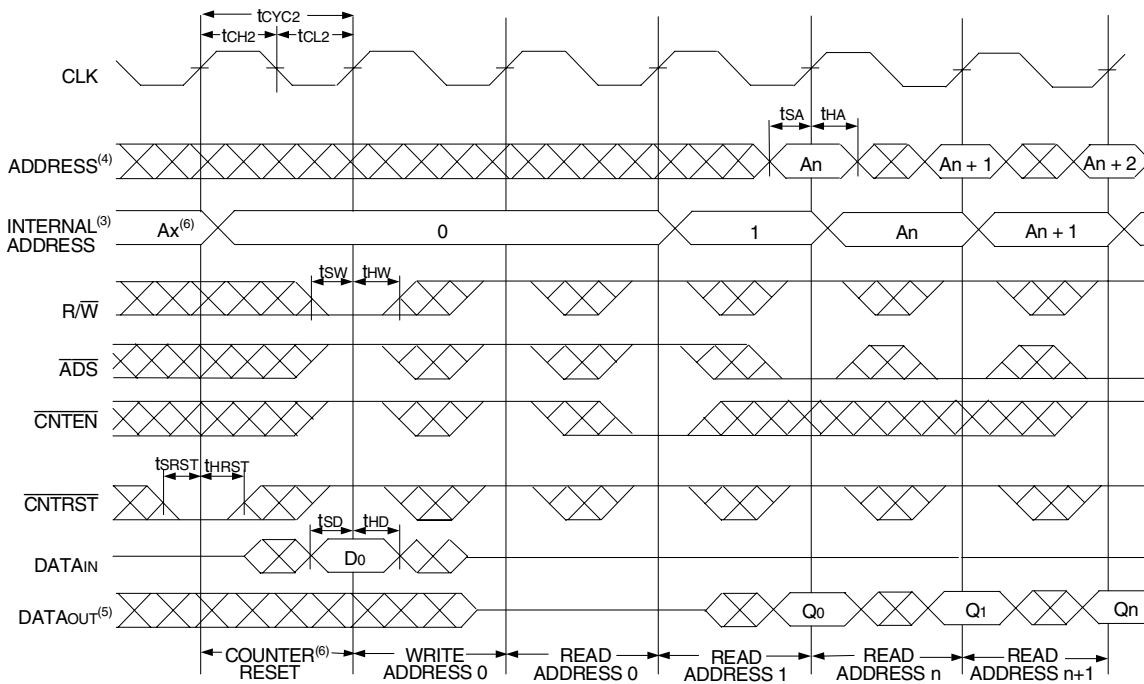

4845 drw 18

### NOTES:

- $\overline{CE}_0, \overline{UB}, \overline{LB}$ , and  $R/\overline{W} = V_{IL}$ ;  $CE_1$  and  $\overline{CNTRST} = V_{IH}$ .
- $\overline{CE}_0, \overline{UB}, \overline{LB} = V_{IL}$ ;  $CE_1 = V_{IH}$ .
- The "Internal Address" is equal to the "External Address" when  $\overline{ADS} = V_{IL}$  and equals the counter output when  $\overline{ADS} = V_{IH}$ .
- Addresses do not have to be accessed sequentially since  $\overline{ADS} = V_{IL}$  constantly loads the address on the rising edge of the CLK; numbers are for reference use only.
- Output state (High, Low, or High-impedance) is determined by the previous cycle control signals.
- No dead cycle exists during counter reset. A READ or WRITE cycle may be coincidental with the counter reset cycle.
- $\overline{CNTEN} = V_{IL}$  advances Internal Address from 'An' to 'An + 1'. The transition shown indicates the time required for the counter to advance. The 'An + 1' Address is written to during this cycle.

## A Functional Description

The IDT709379/69 provides a true synchronous Dual-Port Static RAM interface. Registered inputs provide minimal set-up and hold times on address, data, and all critical control inputs. All internal registers are clocked on the rising edge of the clock signal, however, the self-timed internal write pulse is independent of the LOW to HIGH transition of the clock signal.

An asynchronous output enable is provided to ease asynchronous bus interfacing. Counter enable inputs are also provided to stall the operation of the address counters for fast interleaved memory applications.

$\overline{CE}_0 = V_{IH}$  or  $CE_1 = V_{IL}$  for one clock cycle will power down the internal circuitry to reduce static power consumption. Multiple chip enables allow easier banking of multiple IDT709379/69's for depth expansion configurations. When the Pipelined output mode is enabled, two cycles are required with  $\overline{CE}_0 = V_{IL}$  and  $CE_1 = V_{IH}$  to re-activate the outputs.

## Depth and Width Expansion

The IDT709379/69 features dual chip enables (refer to Truth Table I) in order to facilitate rapid and simple depth expansion with no requirements for external logic. Figure 4 illustrates how to control the various chip enables in order to expand two devices in depth.

The IDT709379/69 can also be used in applications requiring expanded width, as indicated in Figure 4. Since the banks are allocated at the discretion of the user, the external controller can be set up to drive the input signals for the various devices as required to allow for 36-bit or wider applications.

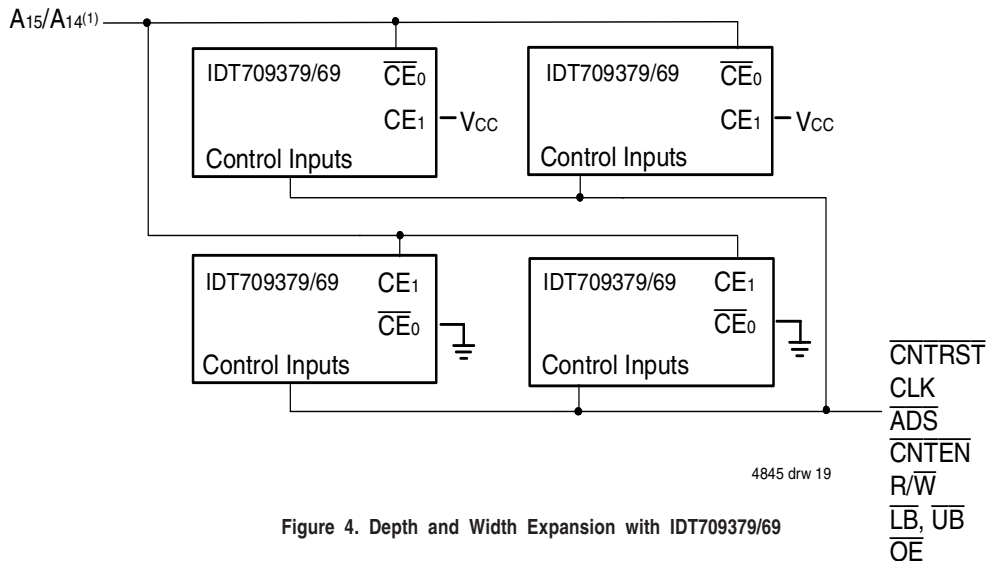
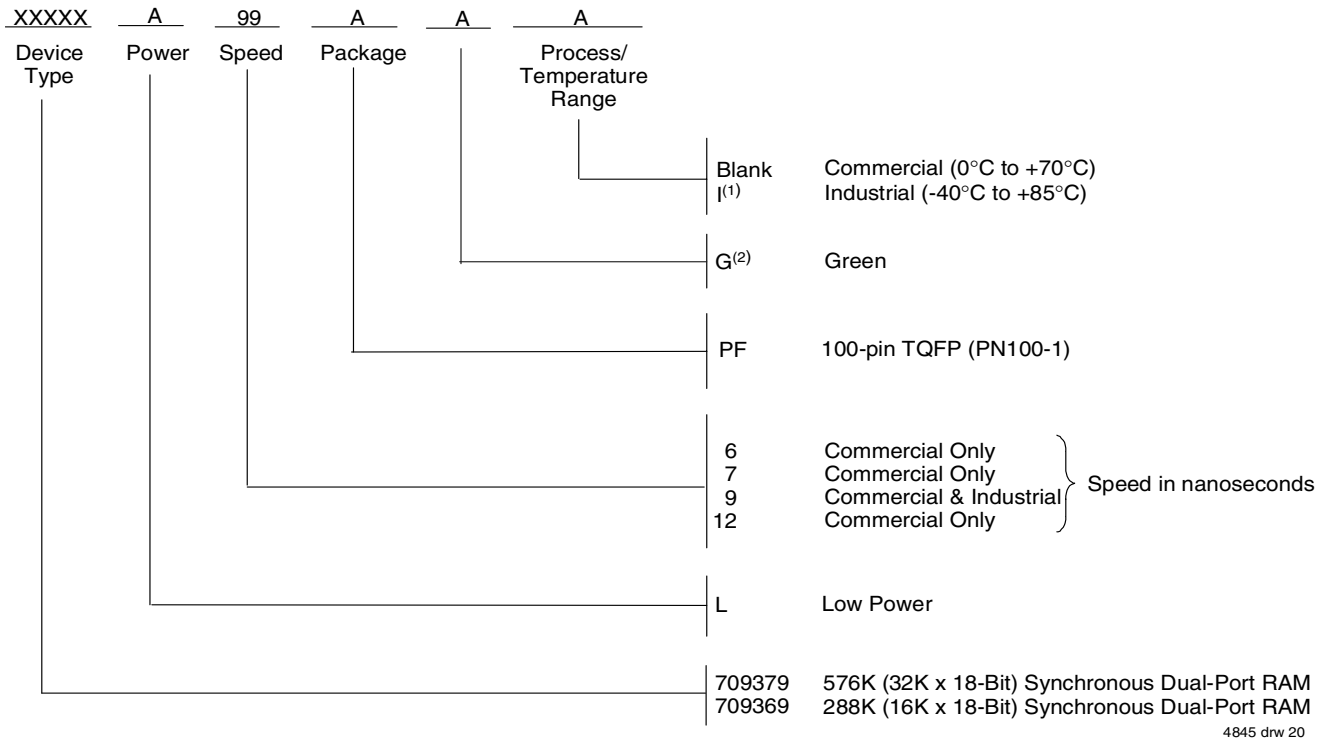

Figure 4. Depth and Width Expansion with IDT709379/69

**NOTE:**

1. A14 is for IDT709369.

## Ordering Information



**NOTE:**

1. Industrial temperature range is available. For other speeds, packages and powers contact your sales office
2. Green parts available. For specific speeds, packages and powers contact your sales office.

## IDT Clock Solution for IDT709379/69 Dual-Port

| IDT Dual-Port Part Number | Dual-Port I/O Specifications |     | Clock Specifications |                              |                   |                  | IDT PLL Clock Device | IDT Non-PLL Clock Device            |
|---------------------------|------------------------------|-----|----------------------|------------------------------|-------------------|------------------|----------------------|-------------------------------------|
|                           | Voltage                      | I/O | Input Capacitance    | Input Duty Cycle Requirement | Maximum Frequency | Jitter Tolerance |                      |                                     |
| 709379/69                 | 5                            | TTL | 9pF                  | 40%                          | 100               | 150ps            | FCT88915TT           | 49FCT805T<br>49FCT806T<br>74FCT807T |

4860 tbl 12

## Datasheet Document History

|           |             |   |
|-----------|-------------|---|
| 9/30/99:  |             | Initial Public Release  |
| 11/10/99: |             | Replaced IDT log  |
| 12/22/99: | Page 1      | Added nmissing diamond  |
| 1/12/01:  | Page 4      | Changed information in Truth Table II   |
|           |             | Increased storage temperature parameter   |
|           |             | Clarified TA parameter  |
|           | Page 5      | DC Electrical parameters—changed wording from "open" to "disabled"  |
|           |             | Changed $\pm 200\text{mV}$ to $0\text{mV}$ in notes   |
| 04/26/04: |             | Removed Preliminary status  |
|           |             | Consolidated multiple devices into one datasheet  |
|           |             | Removed I-temp footnote   |
|           | Page 2      | Added date revision to pin configuration  |
|           | Page 4      | Added Junction Temperature to Absolute Maximum Ratings Table  |
|           |             | Added Ambient Temperature footnote  |
|           | Page 5      | Added I-temp numbers for 9ns speed to the DC Electrical Characteristics Table   |
|           |             | Added 6ns speed DC timing numbers to the DC Electrical Characteristics Table  |
|           | Page 7      | Added I-temp for 9ns speed to AC Electrical Characteristics Table   |
|           |             | Added 6ns speed AC timing numbers to the AC Electrical Characteristics Table  |
|           | Page 15     | Added 6ns speed grade and 9ns I-temp to ordering information  |
|           |             | Added IDT Clock Solution Table  |
|           | Page 1 & 16 | Replaced old $\text{TM}$ logo with new $\text{TM}$ logo   |
| 01/29/09: | Page 15     | Removed "IDT" from orderable part number  |
| 07/26/10: | Page 1      | Added green parts availability to features  |
|           | Page 15     | Added green indicator to ordering information   |
|           | Page 7      | In order to correct the header notes of the AC Elect Chars Table and align them with the Industrial temp range values located in the table, the commercial TA header note has been removed  |
|           | Pages 8-11  | In order to correct the footnotes of timing diagrams, $\overline{\text{CNTEN}}$ has been removed to reconcile the footnotes with the $\overline{\text{CNTEN}}$ logic definition found in Truth Table II - Address Counter Control |



**CORPORATE HEADQUARTERS**  
6024 Silver Creek Valley Road  
San Jose, CA 95138

**for SALES:**  
800-345-7015 or 408-284-8200  
fax: 408-284-2775  
www.idt.com

**for Tech Support:**  
408-284-2794  
DualPortHelp@idt.com

The IDT logo is a registered trademark of Integrated Device Technology, Inc.