



HIGH-SPEED 4K x 9DUAL-PORT STATIC RAM

IDT7014S

Features:

- ♦ **True Dual-Ported** memory cells which allow simultaneous reads of the same memory location
- ♦ **High-speed access**
 - Commercial: 12/15/20/25ns (max.)
 - Industrial: 20ns (max.)
- ♦ **Standard-power operation**
 - IDT7014S
Active: 750mW (typ.)
- ♦ **Fully asynchronous operation from either port**
- ♦ **TTL-compatible; single 5V ($\pm 10\%$) power supply**
- ♦ **Available in 52-pin PLCC and a 64-pin TQFP**
- ♦ **Industrial temperature range (-40°C to $+85^{\circ}\text{C}$) is available for selected speeds**
- ♦ **Green parts available, see ordering information**

Description:

The IDT7014 is a high-speed 4K x 9 Dual-Port Static RAM designed to be used in systems where on-chip hardware port arbitration is not needed. This part lends itself to high-speed applications which do not rely on BUSY signals to manage simultaneous access.

The IDT7014 provides two independent ports with separate control, address, and I/O pins that permit independent, asynchronous access for reads or writes to any location in memory. See functional description.

The IDT7014 utilizes a 9-bit wide data path to allow for parity at the user's option. This feature is especially useful in data communication applications where it is necessary to use a parity bit for transmission/reception error checking.

Fabricated using IDT's high-performance technology, these Dual-Ports typically operate on only 750mW of power at maximum access times as fast as 12ns.

The IDT7014 is packaged in a 52-pin PLCC and a 64-pin thin quad flatpack, (TQFP).

Functional Block Diagram

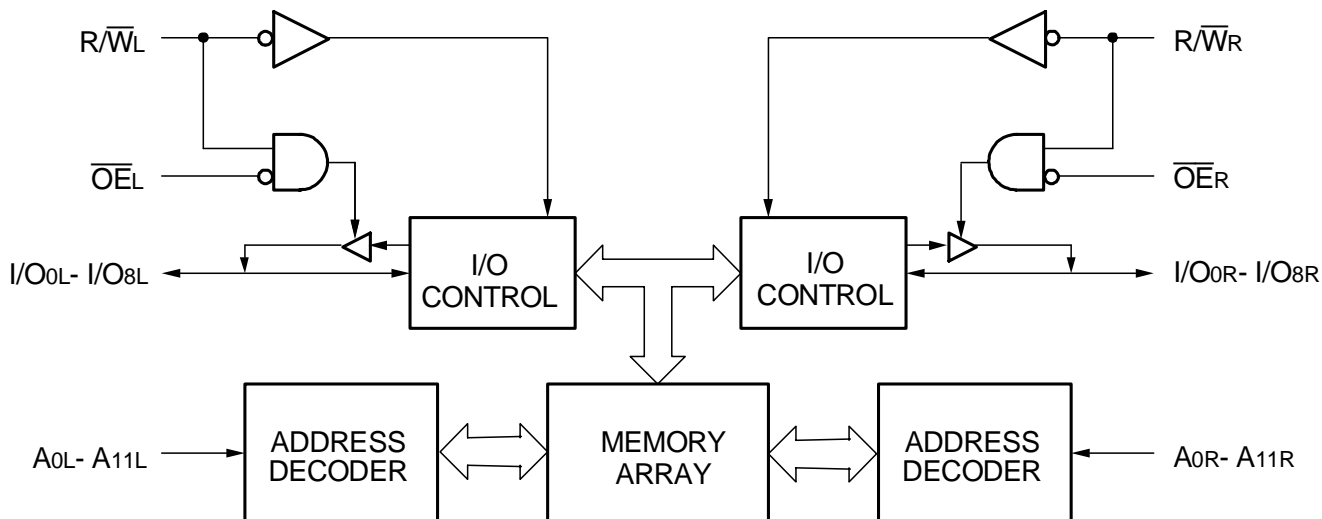

2528 drw 01

DECEMBER 2008

Pin Configuration(1,2,3)

11/16/01

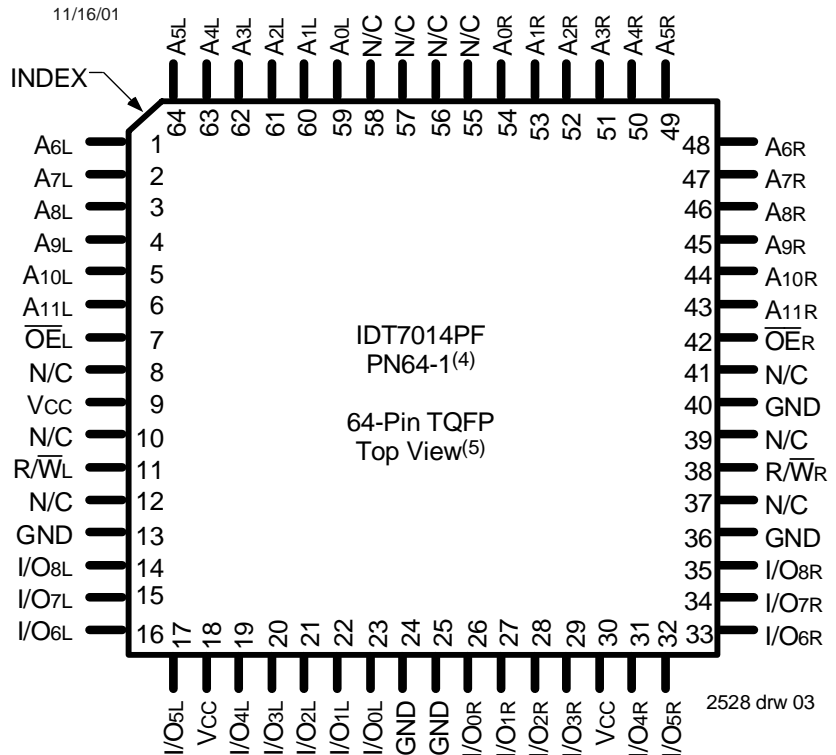
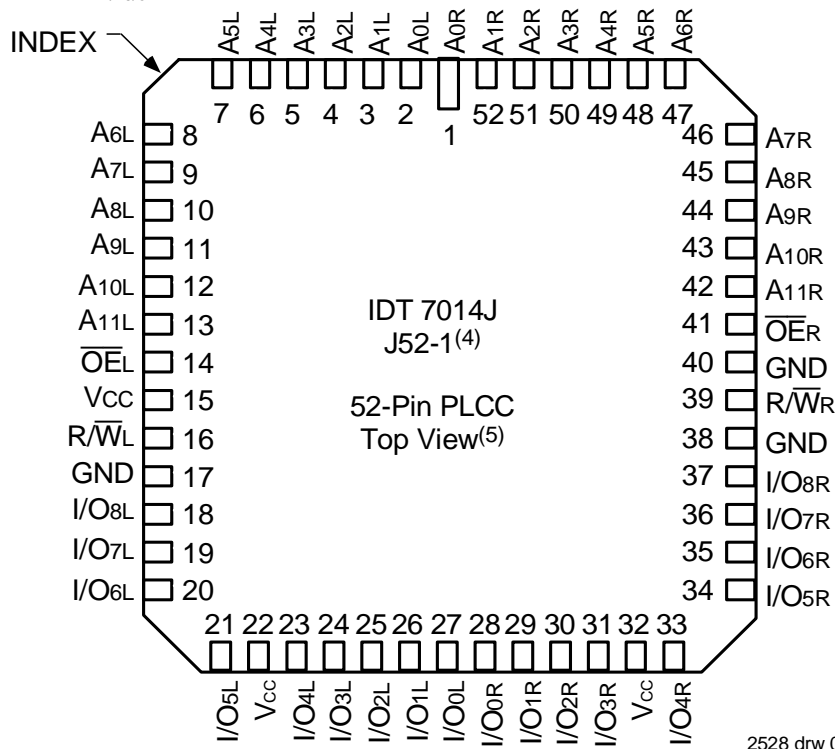

NOTES:

1. All Vcc pins must be connected to power supply.
2. All GND pins must be connected to ground supply.
3. J52-1 package body is approximately .75 in x .75 in x .17 in.
PN64-1 package body is approximately 14mm x 14mm x 1.4mm.
4. This package code is used to reference the package diagram.
5. This text does not indicate the orientation of the actual part-marking

Absolute Maximum Ratings ⁽¹⁾

Symbol	Rating	Commercial & Industrial	Unit
V _{TERM} ⁽²⁾	Terminal Voltage with Respect to GND	-0.5 to +7.0	V
V _{TERM} ⁽²⁾	Terminal Voltage	-0.5 to +V _{CC}	V
T _{BIAS}	Temperature Under Bias	-55 to +125	°C
T _{STG}	Storage Temperature	-65 to +150	°C
I _{OUT}	DC Output Current	50	mA

2528 tbl 01

NOTES:

- Stresses greater than those listed under ABSOLUTE MAXIMUM RATINGS may cause permanent damage to the device. This is a stress rating only and functional operation of the device at these or any other conditions above those indicated in the operational sections of this specification is not implied. Exposure to absolute maximum rating conditions for extended periods may affect reliability.
- V_{TERM} must not exceed V_{CC} + 10% for more than 25% of the cycle time or 10ns maximum, and is limited to ≤ 20mA for the period of V_{TERM} ≥ V_{CC} + 10%.

Maximum Operating Temperature and Supply Voltage ^(1,2)

Grade	Ambient Temperature	GND	V _{CC}
Commercial	0°C to +70°C	0V	5.0V ± 10%
Industrial	-40°C to +85°C	0V	5.0V ± 10%

2528 tbl 02

NOTES:

- This is the parameter T_A. This is the "instant on" case temperature.

Recommended DC Operating Conditions

Symbol	Parameter	Min.	Typ.	Max.	Unit
V _{CC}	Supply Voltage	4.5	5.0	5.5	V
GND	Ground	0	0	0	V
V _{IH}	Input High Voltage	2.2	—	6.0 ⁽²⁾	V
V _{IL}	Input Low Voltage	-0.5 ⁽¹⁾	—	0.8	V

2528 tbl 03

NOTES:

- V_{IL} ≥ -1.5V for pulse width less than 10ns.
- V_{TERM} must not exceed V_{CC} + 10%.

DC Electrical Characteristics Over the Operating Temperature and Supply Voltage Range ⁽¹⁾ (V_{CC} = 5.0V ± 10%)

Symbol	Parameter	Test Conditions	7014S		Unit
			Min.	Max.	
I _{Ll}	Input Leakage Current	V _{CC} = 5.5V, V _{IN} = 0V to V _{CC}	—	10	μA
I _{Ll}	Output Leakage Current	V _{OUT} = 0V to V _{CC}	—	10	μA
V _{OL}	Output Low Voltage	I _{OL} = +4mA	—	0.4	V
V _{OH}	Output High Voltage	I _{OH} = -4mA	2.4	—	V

2528 tbl 04

NOTE:

- At V_{CC} ≤ 2.0V input leakages are undefined.

DC Electrical Characteristics Over the Operating Temperature and Supply Voltage Range ($V_{CC} = 5V \pm 10\%$)

Symbol	Parameter	Test Condition	Version	7014S12 Com'l Only		7014S15 Com'l Only		Unit	
				Typ.	Max	Typ.	Max		
I _{CC}	Dynamic Operating Current (Both Ports Active)	Outputs Open $f = f_{MAX}^{(1)}$	COM'L	S	160	250	160	250	mA
			IND	S	—	—	—	—	

2528 tbl 05a

Symbol	Parameter	Test Condition	Version	7014S20 Com'l & Ind		7014S25 Com'l Only		Unit	
				Typ.	Max	Typ.	Max		
I _{CC}	Dynamic Operating Current (Both Ports Active)	Outputs Open $f = f_{MAX}^{(1)}$	COM'L	S	155	245	150	240	mA
			IND	S	155	260	—	—	

2528 tbl 05b

NOTES:

- At $f = f_{max}$, address inputs are cycling at the maximum read cycle of $1/t_{RC}$ using the "AC Test Conditions" input levels of GND to 3V.

AC Test Conditions

Input Pulse Levels	GND to 3.0V
Input Rise/Fall Times	3ns Max.
Input Timing Reference Levels	1.5V
Output Reference Levels	1.5V
Output Load	Figures 1,2 and 3

2528 tbl 06

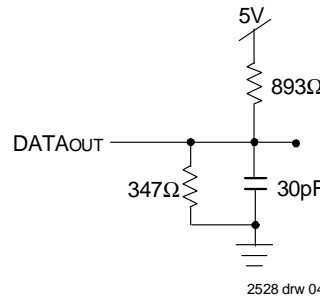

2528 drw 04

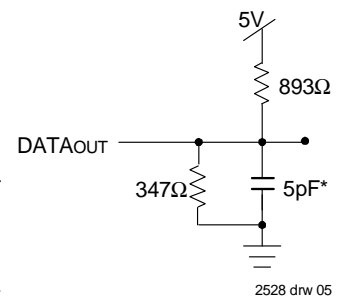

2528 drw 05

Figure 1. AC Output Test Load.

Figure 2. Output Test Load (for t_{HZ}, t_{WZ}, and t_{OW})
*Including scope and jig.

Capacitance⁽¹⁾

($T_A = +25^\circ\text{C}$, $f = 1.0\text{MHz}$) TQFP Package Only

Symbol	Parameter	Conditions ⁽²⁾	Max	Unit
C _{IN}	Input Capacitance	V _{IN} = 3dV	9	pF
C _{OUT}	Output Capacitance	V _{OUT} = 3dV	10	pF

2528 tbl 07

NOTES:

- This parameter is determined by device characteristics but is not production tested.
- 3dV references the interpolated capacitance when the input and output signals switch from 0V to 3V or from 3V to 0V.

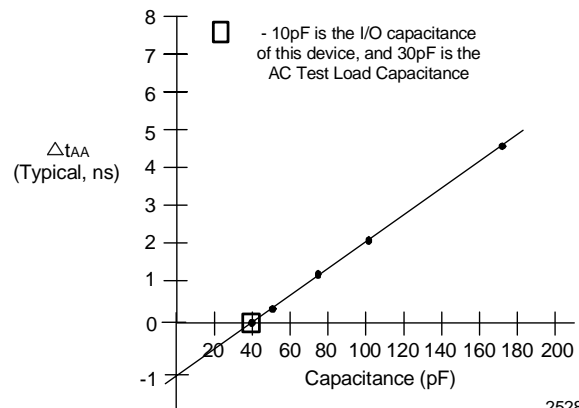

2528 drw 06

Figure 3. Typical Output Derating (Lumped Capacitive Load).

AC Electrical Characteristics Over the Operating Temperature and Supply Voltage

Symbol	Parameter	7014S12 Com'l Only		7014S15 Com'l Only		Unit
		Min.	Max.	Min.	Max.	
READ CYCLE						
t _{RC}	Read Cycle Time	12	—	15	—	ns
t _{AA}	Address Access Time	—	12	—	15	ns
t _{AOE}	Output Enable Access Time	—	8	—	8	ns
t _{OH}	Output Hold from Address Change	3	—	3	—	ns
t _{LZ}	Output Low-Z Time ^(1,2)	3	—	3	—	ns
t _{HZ}	Output High-Z Time ^(1,2)	—	7	—	7	ns

2528 tbl 08a

Symbol	Parameter	7014S20 Com'l & Ind		7014S25 Com'l Only		Unit
		Min.	Max.	Min.	Max.	
READ CYCLE						
t _{RC}	Read Cycle Time	20	—	25	—	ns
t _{AA}	Address Access Time	—	20	—	25	ns
t _{AOE}	Output Enable Access Time	—	10	—	12	ns
t _{OH}	Output Hold from Address Change	3	—	3	—	ns
t _{LZ}	Output Low-Z Time ^(1,2)	3	—	3	—	ns
t _{HZ}	Output High-Z Time ^(1,2)	—	9	—	11	ns

2528 tbl 08b

NOTES:

1. Transition is measured 0mV from Low or High-impedance voltage with Output Test Load (Figure 2).
2. This parameter is determined by device characterization, but is not production tested.

Timing Waveform of Read Cycle No. 1, Either Side^(1,2)

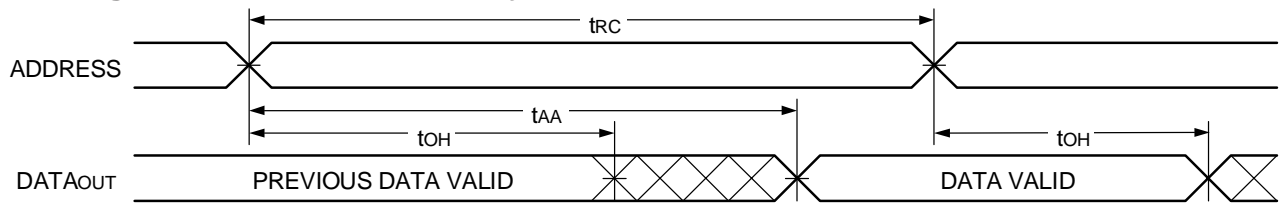

2528 drw 07

Timing Waveform of Read Cycle No. 2, Either Side^(1, 3)

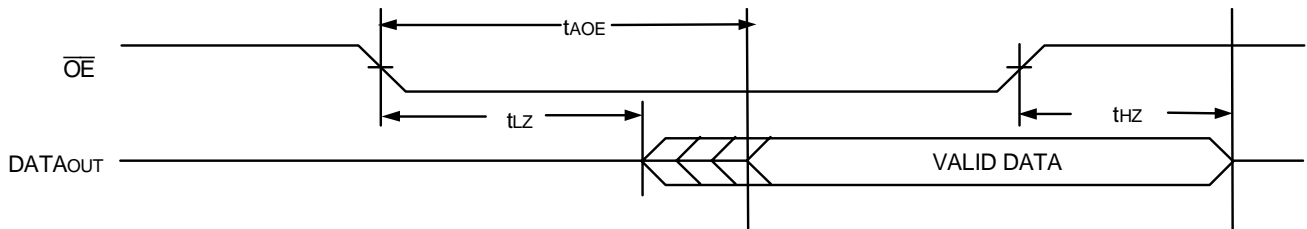

2528 drw 08

NOTES:

1. $R\bar{W} = V_{IH}$ for Read Cycles.
2. $\bar{OE} = V_{IL}$.
3. Addresses valid prior to \bar{OE} transition LOW.

Timing Waveform of Write with Port-to-Port Read^(1,2)

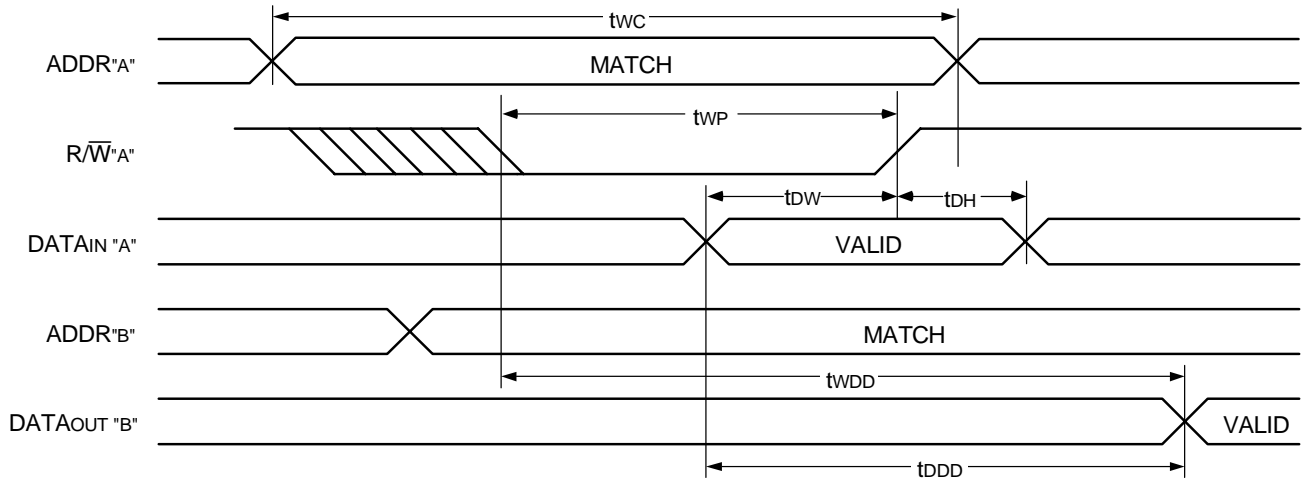

2528 drw 09

NOTES:

1. $R\bar{W}'B' = V_{IH}$, read cycle pass through.
2. All timing is the same for left and right ports. Port "A" may be either left or right port. Port "B" is opposite from port "A".

AC Electrical Characteristics Over the Operating Temperature and Supply Voltage

Symbol	Parameter	7014S12 Com'l Only		7014S15 Com'l Only		Unit
		Min.	Max.	Min.	Max.	
WRITE CYCLE						
t _{WC}	Write Cycle Time	12	—	15	—	ns
t _{AW}	Address Valid to End-of-Write	10	—	14	—	ns
t _{AS}	Address Set-up Time	0	—	0	—	ns
t _{WP}	Write Pulse Width	10	—	12	—	ns
t _{WR}	Write Recovery Time	1	—	1	—	ns
t _{DW}	Data Valid to End-of-Write	8	—	10	—	ns
t _{HZ}	Output High-Z Time ^(1,2)	—	7	—	7	ns
t _{DH}	Data Hold Time ⁽³⁾	0	—	0	—	ns
t _{WZ}	Write Enable to Output in High-Z ^(1,2)	—	7	—	7	ns
t _{OW}	Output Active from End-of-Write ^(1,2,3)	0	—	0	—	ns
t _{WDD}	Write Pulse to Data Delay ⁽⁴⁾	—	25	—	30	ns
t _{DDD}	Write Data Valid to Read Data Delay ⁽⁴⁾	—	22	—	25	ns

2528 tbl 09a

Symbol	Parameter	7014S20 Com'l & Ind		7014S25 Com'l Only		Unit
		Min.	Max.	Min.	Max.	
WRITE CYCLE						
t _{WC}	Write Cycle Time	20	—	25	—	ns
t _{AW}	Address Valid to End-of-Write	15	—	20	—	ns
t _{AS}	Address Set-up Time	0	—	0	—	ns
t _{WP}	Write Pulse Width	15	—	20	—	ns
t _{WR}	Write Recovery Time	2	—	2	—	ns
t _{DW}	Data Valid to End-of-Write	12	—	15	—	ns
t _{HZ}	Output High-Z Time ^(1,2)	—	9	—	11	ns
t _{DH}	Data Hold Time ⁽³⁾	0	—	0	—	ns
t _{WZ}	Write Enable to Output in High-Z ^(1,2)	—	9	—	11	ns
t _{OW}	Output Active from End-of-Write ^(1,2,3)	0	—	0	—	ns
t _{WDD}	Write Pulse to Data Delay ⁽⁴⁾	—	40	—	45	ns
t _{DDD}	Write Data Valid to Read Data Delay ⁽⁴⁾	—	30	—	35	ns

2528 tbl 09b

NOTES:

1. Transition is measured 0mV from Low or High-impedance voltage with Output Test Load (Figure 2).
2. This parameter is guaranteed by device characterization, but is not production tested.
3. The specification for t_{DH} must be met by the device supplying write data to the RAM under all operating conditions. Although t_{DH} and t_{OW} values will vary over voltage and temperature, the actual t_{DH} will always be smaller than the actual t_{OW}.
4. Port-to-port delay through RAM cells from writing port to reading port, refer to "Timing Waveform of Write With Port-to-Port Read".

Timing Waveform of Write Cycle^(1,2,3,4,5)

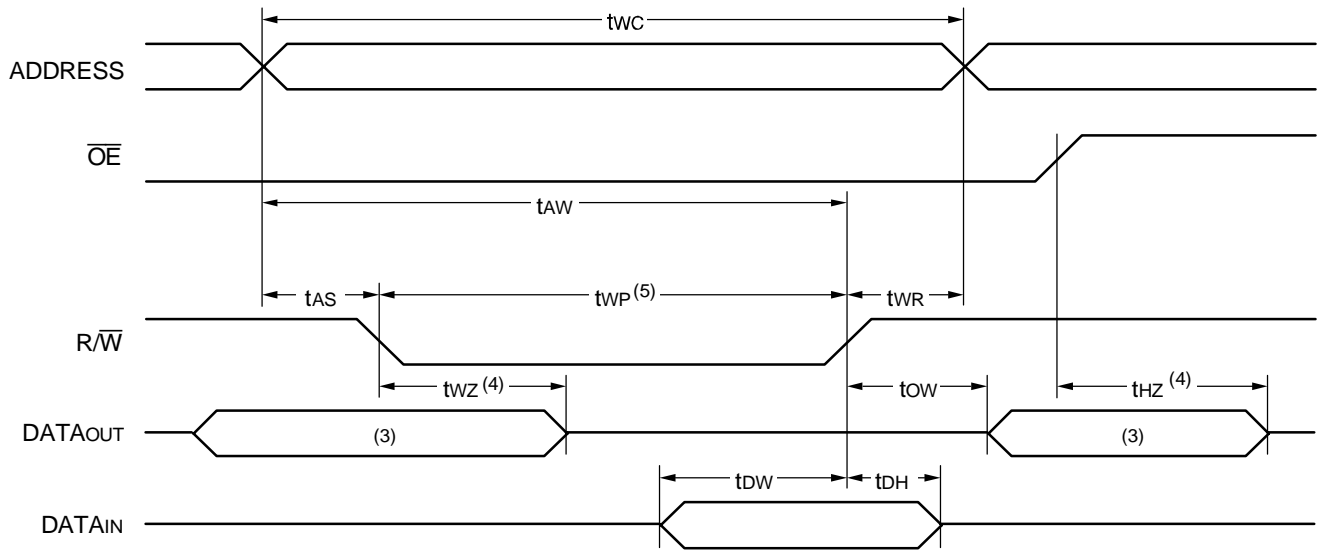

2528 drw 10

NOTES:

- R/\overline{W} must be HIGH during all address transitions.
- t_{WR} is measured from R/\overline{W} going HIGH to the end of write cycle.
- During this period, the I/O pins are in the output state, and input signals must not be applied.
- Transition is measured 0mV from the Low or High-impedance voltage with the Output Test Load (Figure 2).
- If \overline{OE} is LOW during a R/\overline{W} controlled write cycle, the write pulse width must be the larger of t_{WP} or $(t_{WZ} + t_{OW})$ to allow the I/O drivers to turn off data to be placed on the bus for the required t_{OW} . If \overline{OE} is HIGH during an R/\overline{W} controlled write cycle, this requirement does not apply and the write pulse can be as short as the specified t_{WP} .

Functional Description

The IDT7014 provides two ports with separate control, address, and I/O pins that permit independent access for reads or writes to any location in memory. It lacks the chip enable feature of CMOS Dual Ports, thus it operates in active mode as soon as power is applied. Each port has its own Output Enable control (\overline{OE}). In the read mode, the port's \overline{OE} turns on the output drivers when set LOW. The user application should avoid simultaneous write operations to the same memory location. There is no on-chip arbitration circuitry to resolve write priority and partial data from both ports may be written. READ/WRITE conditions are illustrated in Table 1.

Truth Table I – Read/Write Control

Left or Right Port ⁽¹⁾			Function
R/\overline{W}	\overline{OE}	D0-8	
L	X	DATAIN	Data written into memory
H	L	DATAOUT	Data in memory output on port
X	H	Z	High-impedance outputs

2528 tbl 10

NOTE:

- A0L - A11L is not equal to A0R - A11R.
'H' = HIGH, 'L' = LOW, 'X' = Don't Care, and 'Z' = HIGH Impedance.

Ordering Information

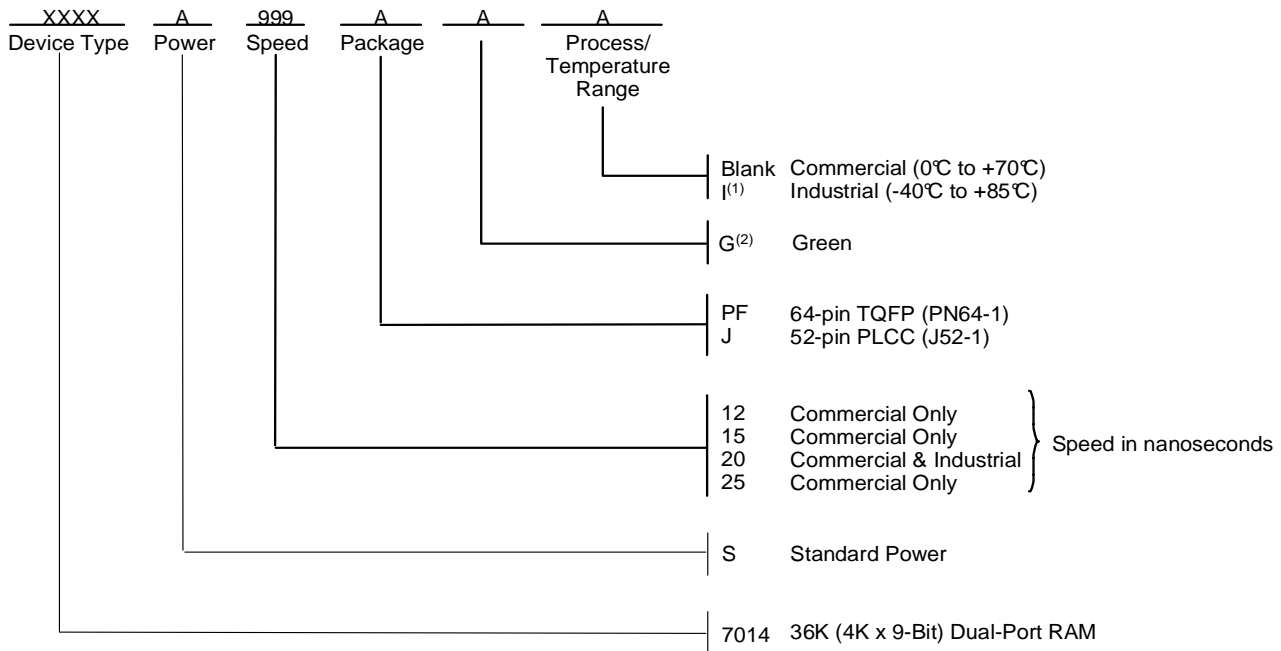

NOTES:

2528 drw 11

1. Industrial temperature: for other speeds, packages and powers contact your sales office.
2. Green parts available. For specific speeds, packages and powers contact your local sales office.

Datasheet Document History

01/06/99:		Initiated datasheet document history Converted to new format Cosmetic and typographical corrections
06/03/99:	Page 2	Added additional notes to pin configurations Changed drawing format
03/10/00:	Page 1	Corrected DSC number Added Industrial Temperature Ranges and deleted corresponding notes Replaced IDT logo
05/19/00:	Page 6 Page 3	Made corrections to drawing Changed ±200mV to 0mV in notes Made changes to drawings Increased storage temperature parameter Clarified TA parameter
10/16/01:	Page 2 Pages 4, 5 & 7 Page 9	Added date revision for pin configuration Removed Industrial temp values and column headings for 15 & 25ns speeds from DC and AC Electrical Characteristics Removed Industrial temp offering from 15 & 25ns ordering information Added Industrial temp footnote to ordering information
04/04/06:	Pages 1 & 9 Page 1 Page 9	Replaced τ_m logo with @ logo Added green availability to features Added green indicator to ordering information
12/11/08:	Page 9	Removed "IDT" from orderable part number



CORPORATE HEADQUARTERS
 6024 Silver Creek Valley Road
 San Jose, CA 95138

for SALES:
 800-345-7015 or 408-284-8200
 fax: 408-284-2775
 www.idt.com

for Tech Support:
 408-284-2794
 DualPortHelp@idt.com

The IDT logo is a registered trademark of Integrated Device Technology, Inc.