



## 3.3V CMOS 18-BIT UNIVERSAL BUS DRIVER WITH 3-STATE OUTPUTS

**IDT74ALVCF162835A**

### FEATURES:

- 0.5 MICRON CMOS Technology
- Typical  $t_{sk(o)}$  (Output Skew) < 250ps
- ESD > 2000V per MIL-STD-883, Method 3015; > 200V using machine model (C = 200pF, R = 0)
- $V_{cc} = 3.3V \pm 0.3V$ , Normal Range
- $V_{cc} = 2.7V$  to  $3.6V$ , Extended Range
- $V_{cc} = 2.5V \pm 0.2V$
- CMOS power levels ( $0.4\mu W$  typ. static)
- Rail-to-Rail output swing for increased noise margin
- Available in TSSOP and TVSOP packages

### DRIVE FEATURES:

- Balanced Output Drivers:  $\pm 18mA$
- Low switching noise

### APPLICATIONS:

- SDRAM Modules
- PC Motherboards
- Workstations

### DESCRIPTION:

This 18-bit universal bus driver is built using advanced dual metal CMOS technology. Data flow from A to Y is controlled by the output-enable ( $\overline{OE}$ ) input. The device operates in the transparent mode when the latch-enable (LE) input is high. The A data is latched if the clock (CLK) input is held at a high or low logic level. If LE is low, the A data is stored in the latch flip-flop on the low-to-high transition of CLK. When  $\overline{OE}$  is high, the outputs are in the high-impedance state.

The ALVCF162835A has series resistors in the device output structure which will reduce switching noise in 128MB and 256MB SDRAM modules. Designed with a drive capability of  $\pm 18mA$ , the ALVCF162835A is a mid-way drive between the ALVC162835 ( $\pm 12mA$ ) and ALVC16835 ( $\pm 24mA$ ).

The ALVCF162835A is a faster version of the ALVCF162835 or ALVC162835. It is suitable for PC133 applications and particularly SDRAM Modules clocked at 133 MHz.

### FUNCTIONAL BLOCK DIAGRAM

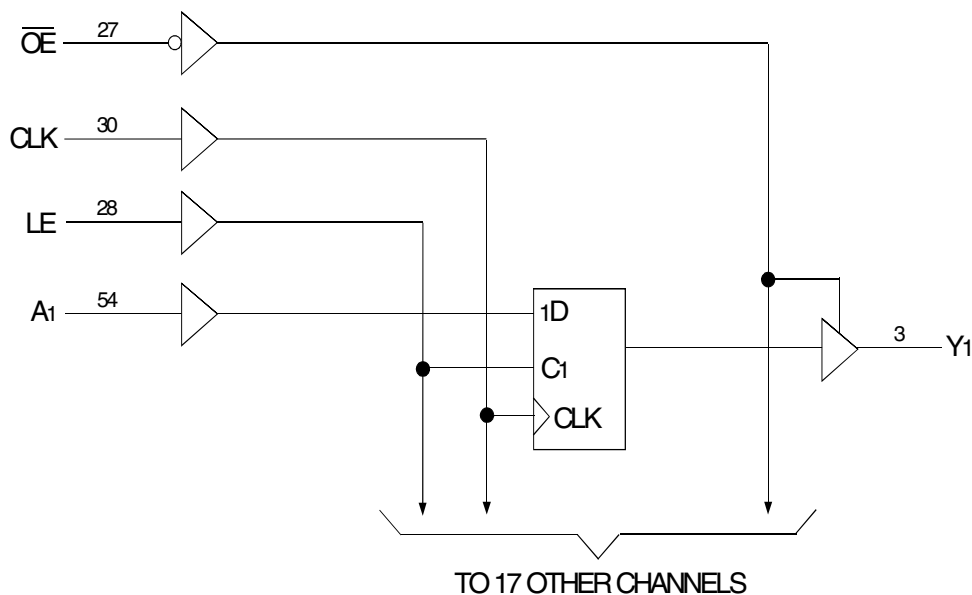

## PIN CONFIGURATION

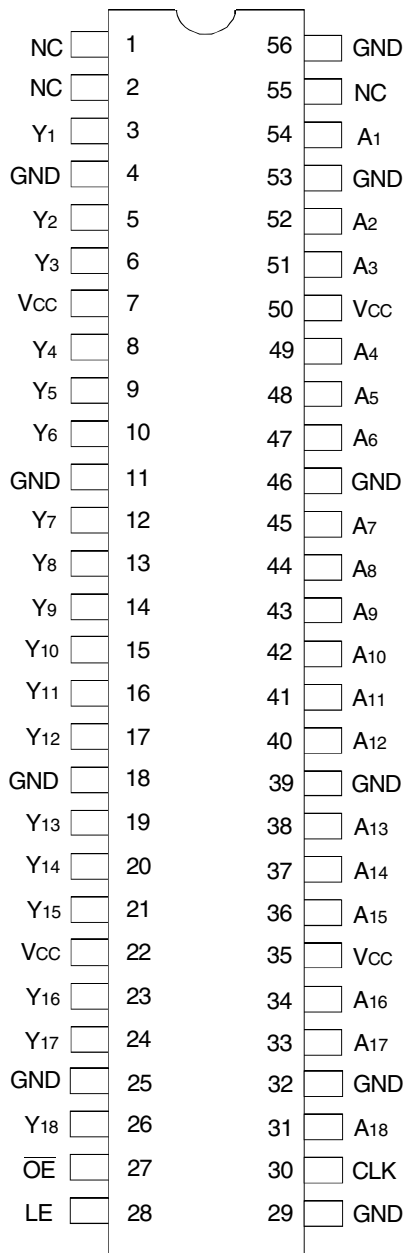

TSSOP/TVSOP  
TOP VIEW

## PIN DESCRIPTION

Pin Names	Description
$\overline{OE}$	3-State Output Enable Inputs (Active LOW)
CLK	Register Input Clock
LE	Latch Enable (Transparent HIGH)
Ax	Data Inputs
Yx	3-State Outputs

## ABSOLUTE MAXIMUM RATINGS<sup>(1)</sup>

Symbol	Description	Max	Unit
VTERM <sup>(2)</sup>	Terminal Voltage with Respect to GND	-0.5 to +4.6	V
VTERM <sup>(3)</sup>	Terminal Voltage with Respect to GND	-0.5 to VCC+0.5	V
TSTG	Storage Temperature	-65 to +150	°C
IOUT	DC Output Current	-50 to +50	mA
I <sub>IK</sub>	Continuous Clamp Current, V <sub>I</sub> < 0 or V <sub>I</sub> > VCC	±50	mA
I <sub>OK</sub>	Continuous Clamp Current, V <sub>O</sub> < 0	-50	mA
I <sub>CC</sub> I <sub>SS</sub>	Continuous Current through each VCC or GND	±100	mA

### NOTES:

- Stresses greater than those listed under ABSOLUTE MAXIMUM RATINGS may cause permanent damage to the device. This is a stress rating only and functional operation of the device at these or any other conditions above those indicated in the operational sections of this specification is not implied. Exposure to absolute maximum rating conditions for extended periods may affect reliability.
- VCC terminals.
- All terminals except VCC.

## CAPACITANCE (TA = +25°C, F = 1.0MHz)

Symbol	Parameter <sup>(1)</sup>	Conditions	Min.	Typ.	Max.	Unit
C <sub>IN</sub>	Input Capacitance	V <sub>IN</sub> = 0V	4	5	6	pF
C <sub>OUT</sub>	Output Capacitance	V <sub>OUT</sub> = 0V	—	7	9	pF
C <sub>OUT</sub>	I/O Port Capacitance	V <sub>IN</sub> = 0V	—	7	9	pF

### NOTE:

- As applicable to the device type.

## FUNCTION TABLE<sup>(1)</sup>

Inputs				Outputs
$\overline{OE}$	LE	CLK	Ax	Yx
H	X	X	X	Z
L	H	X	L	L
L	H	X	H	H
L	L	↑	L	L
L	L	↑	H	H
L	L	H	X	Y <sub>0</sub> <sup>(2)</sup>
L	L	L	X	Y <sub>0</sub> <sup>(3)</sup>

### NOTES:

- H = HIGH Voltage Level  
L = LOW Voltage Level  
X = Don't Care  
Z = High-Impedance  
↑ = LOW-to-HIGH Transition
- Output level before indicated steady-state input conditions were established, provided that CLK is HIGH before LE went LOW.
- Output level before the indicated steady-state input conditions were established.

## DC ELECTRICAL CHARACTERISTICS OVER OPERATING RANGE

Following Conditions Apply Unless Otherwise Specified:

Operating Condition:  $T_A = -40^{\circ}\text{C}$  to  $+85^{\circ}\text{C}$

Symbol	Parameter	Test Conditions		Min.	Typ. <sup>(1)</sup>	Max.	Unit
V <sub>IH</sub>	Input HIGH Voltage Level	V <sub>CC</sub> = 2.3V to 2.7V		1.7	—	—	V
		V <sub>CC</sub> = 2.7V to 3.6V		2	—	—	
V <sub>IL</sub>	Input LOW Voltage Level	V <sub>CC</sub> = 2.3V to 2.7V		—	—	0.7	V
		V <sub>CC</sub> = 2.7V to 3.6V		—	—	0.8	
I <sub>IH</sub>	Input HIGH Current	V <sub>CC</sub> = 3.6V	V <sub>I</sub> = V <sub>CC</sub>	—	—	±5	μA
I <sub>IL</sub>	Input LOW Current	V <sub>CC</sub> = 3.6V	V <sub>I</sub> = GND	—	—	±5	μA
I <sub>OZH</sub> I <sub>OZL</sub>	High Impedance Output Current (3-State Output pins)	V <sub>CC</sub> = 3.6V		—	—	±10	μA
		V <sub>O</sub> = GND		—	—	±10	
V <sub>IK</sub>	Clamp Diode Voltage	V <sub>CC</sub> = 2.3V, I <sub>IN</sub> = -18mA		—	-0.7	-1.2	V
V <sub>H</sub>	Input Hysteresis	V <sub>CC</sub> = 3.3V		—	100	—	mV
I <sub>CC1</sub> I <sub>CC2</sub> I <sub>CC3</sub>	Quiescent Power Supply Current	V <sub>CC</sub> = 3.6V V <sub>IN</sub> = GND or V <sub>CC</sub>		—	0.1	40	μA
ΔI <sub>CC</sub>	Quiescent Power Supply Current Variation	One input at V <sub>CC</sub> - 0.6V, other inputs at V <sub>CC</sub> or GND		—	—	750	μA

**NOTE:**

1. Typical values are at V<sub>CC</sub> = 3.3V, +25°C ambient.

## OUTPUT DRIVE CHARACTERISTICS

Symbol	Parameter	Test Conditions <sup>(1)</sup>		Min.	Max.	Unit
V <sub>OH</sub>	Output HIGH Voltage	V <sub>CC</sub> = 2.3V to 3.6V	I <sub>OH</sub> = -0.1mA	V <sub>CC</sub> - 0.2	—	V
		V <sub>CC</sub> = 2.3V	I <sub>OH</sub> = -6mA	1.9	—	
			I <sub>OH</sub> = -8mA	1.7	—	
		V <sub>CC</sub> = 2.7V	I <sub>OH</sub> = -6mA	2.2	—	
			I <sub>OH</sub> = -12mA	2	—	
		V <sub>CC</sub> = 3V	I <sub>OH</sub> = -8mA	2.4	—	
I <sub>OH</sub> = -18mA	2		—			
V <sub>OL</sub>	Output LOW Voltage	V <sub>CC</sub> = 2.3V to 3.6V	I <sub>OL</sub> = 0.1mA	—	0.2	V
		V <sub>CC</sub> = 2.3V	I <sub>OL</sub> = 6mA	—	0.4	
			I <sub>OL</sub> = 8mA	—	0.55	
		V <sub>CC</sub> = 2.7V	I <sub>OL</sub> = 6mA	—	0.4	
			I <sub>OL</sub> = 12mA	—	0.6	
		V <sub>CC</sub> = 3V	I <sub>OL</sub> = 8mA	—	0.55	
I <sub>OL</sub> = 18mA	—		0.8			

**NOTE:**

1. V<sub>IH</sub> and V<sub>IL</sub> must be within the min. or max. range shown in the DC ELECTRICAL CHARACTERISTICS OVER OPERATING RANGE table for the appropriate V<sub>CC</sub> range. T<sub>A</sub> = -40°C to +85°C.

## OPERATING CHARACTERISTICS, T<sub>A</sub> = 25°C

Symbol	Parameter	Test Conditions	V <sub>CC</sub> = 2.5V ± 0.2V	V <sub>CC</sub> = 3.3V ± 0.3V	Unit
			Typical	Typical	
CPD	Power Dissipation Capacitance Outputs enabled	C <sub>L</sub> = 0pF, f = 10Mhz	30	35	pF
CPD	Power Dissipation Capacitance Outputs disabled		12.5	14	

## SWITCHING CHARACTERISTICS<sup>(1)</sup>

Symbol	Parameter	V <sub>CC</sub> = 2.5V ± 0.2V		V <sub>CC</sub> = 2.7V		V <sub>CC</sub> = 3.3V ± 0.3V		Unit
		Min.	Max.	Min.	Max.	Min.	Max.	
f <sub>CLOCK</sub>		150	—	150	—	150	—	MHz
t <sub>PLH</sub> t <sub>PHL</sub>	Propagation Delay A <sub>x</sub> to Y <sub>x</sub>	1	4	—	4.6	1	3.5	ns
t <sub>PLH</sub> t <sub>PHL</sub>	Propagation Delay LE to Y <sub>x</sub>	1.3	5.5	—	5.4	1.3	4.6	ns
t <sub>PLH</sub> t <sub>PHL</sub>	Propagation Delay CLK to Y <sub>x</sub>	1.4	5.9	—	5.6	1.4	3.5	ns
t <sub>PZH</sub> t <sub>PZL</sub>	Output Enable Time $\overline{OE}$ to Y <sub>x</sub>	1.4	5.9	—	6	1.1	5	ns
t <sub>PHZ</sub> t <sub>PLZ</sub>	Output Disable Time $\overline{OE}$ to Y <sub>x</sub>	1	4.7	—	4.6	1.3	4.2	ns
t <sub>w</sub>	Pulse Duration, LE HIGH	3.3	—	3.3	—	3.3	—	ns
t <sub>w</sub>	Pulse Duration, CLK HIGH or LOW	3.3	—	3.3	—	3.3	—	ns
t <sub>SU</sub>	Set-up Time, data before CLK↑	1.8	—	1.5	—	1	—	ns
t <sub>SU</sub>	Set-up Time, data before LE↓, CLK HIGH	1.9	—	1.6	—	1.5	—	ns
t <sub>SU</sub>	Set-up Time, data before LE↓, CLK LOW	1.3	—	1.1	—	1	—	ns
t <sub>H</sub>	Hold Time, data after CLK↑	0.6	—	0.6	—	0.6	—	ns
t <sub>H</sub>	Hold Time, data after LE↓, CLK HIGH or LOW	1.4	—	1.7	—	1.4	—	ns
t <sub>SK(O)</sub>	Output Skew <sup>(2)</sup>	—	—	—	—	—	500	ps

### NOTES:

- See TEST CIRCUITS AND WAVEFORMS. T<sub>A</sub> = -40°C to +85°C.
- Skew between any two outputs of the same package and switching in the same direction.

## SWITCHING CHARACTERISTICS FROM 0°C TO 65°C, C<sub>L</sub> = 50pF

Symbol	Parameter	V <sub>CC</sub> = 3.3V ± 0.15V		Unit
		Min.	Max.	
t <sub>PLH</sub> t <sub>PHL</sub>	Propagation Delay CLK to xY <sub>x</sub>	1.8	3.5	ns

## TEST CIRCUITS AND WAVEFORMS

### TEST CONDITIONS

Symbol	V <sub>CC</sub> <sup>(1)</sup> =3.3V±0.3V	V <sub>CC</sub> <sup>(1)</sup> =2.7V	V <sub>CC</sub> <sup>(2)</sup> =2.5V±0.2V	Unit
V <sub>LOAD</sub>	6	6	2 x V <sub>CC</sub>	V
V <sub>IH</sub>	2.7	2.7	V <sub>CC</sub>	V
V <sub>T</sub>	1.5	1.5	V <sub>CC</sub> / 2	V
V <sub>LZ</sub>	300	300	150	mV
V <sub>HZ</sub>	300	300	150	mV
C <sub>L</sub>	50	50	30	pF

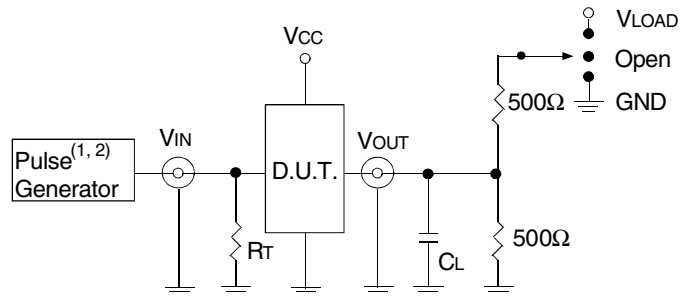

Test Circuit for All Outputs

#### DEFINITIONS:

C<sub>L</sub> = Load capacitance: includes jig and probe capacitance.  
R<sub>T</sub> = Termination resistance: should be equal to Z<sub>OUT</sub> of the Pulse Generator.

#### NOTES:

1. Pulse Generator for All Pulses: Rate ≤ 1.0MHz; t<sub>r</sub> ≤ 2.5ns; t<sub>r</sub> ≤ 2.5ns.
2. Pulse Generator for All Pulses: Rate ≤ 1.0MHz; t<sub>r</sub> ≤ 2ns; t<sub>r</sub> ≤ 2ns.

### SWITCH POSITION

Test	Switch
Open Drain Disable Low Enable Low	V <sub>LOAD</sub>
Disable High Enable High	GND
All Other Tests	Open

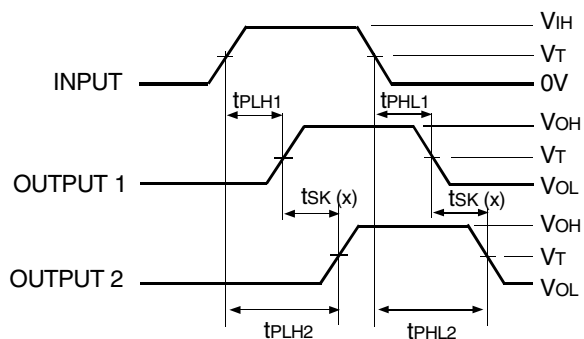

$$tsk(x) = |t_{PLH2} - t_{PLH1}| \text{ or } |t_{PHL2} - t_{PHL1}|$$

Output Skew - tsk(x)

#### NOTES:

1. For tsk(o) OUTPUT1 and OUTPUT2 are any two outputs.
2. For tsk(b) OUTPUT1 and OUTPUT2 are in the same bank.

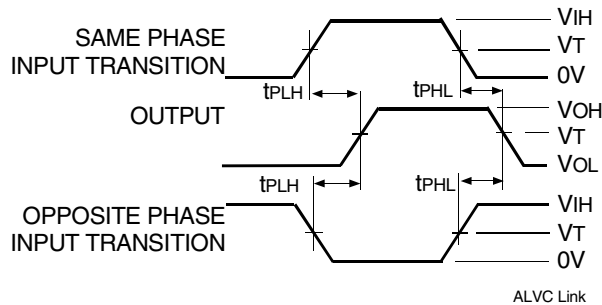

Propagation Delay

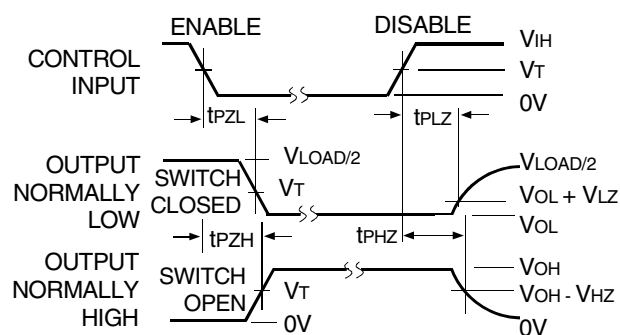

Enable and Disable Times

#### NOTE:

1. Diagram shown for input Control Enable-LOW and input Control Disable-HIGH.

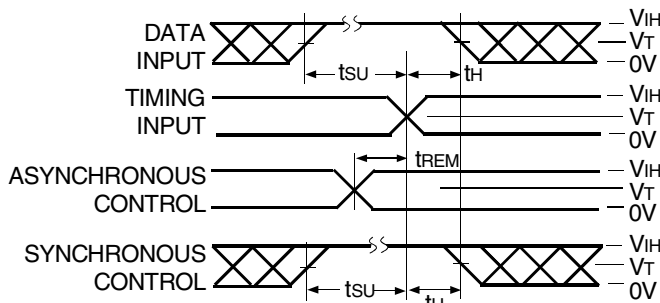

Set-up, Hold, and Release Times

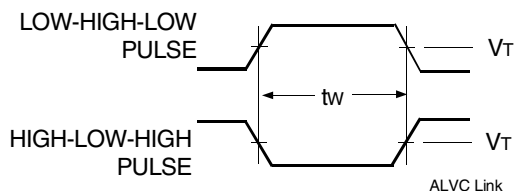

Pulse Width

## ORDERING INFORMATION

<u>XX</u>	<u>ALVC</u>	<u>X</u>	<u>XXX</u>	<u>XXX</u>	<u>XX</u>	
Temp. Range	Bus-Hold	Family	Device Type	Package		
					PA	Thin Shrink Small Outline Package
					PAG	TSSOP - Green
					PF	Thin Very Small Outline Package
					PFG	TVSOP - Green
					835A	18-Bit Universal Bus Driver with 3-State Outputs
					F162	Double-Density with Resistors, ±18mA
					Blank	No Bus-hold
					74	- 40°C to +85°C



**CORPORATE HEADQUARTERS**  
 6024 Silver Creek Valley Road  
 San Jose, CA 95138

**for SALES:**  
 800-345-7015 or 408-284-8200  
 fax: 408-284-2775  
 www.idt.com

**for Tech Support:**  
 logichelp@idt.com