



Description

The TSE2002GB2A1 digital temperature sensor with accuracy up to $\pm 0.5^{\circ}\text{C}$ was designed to target applications demanding highest level of temperature readout. The device also contains 256 Byte EEPROM for storage of vendor information and system configuration such as SPD for DIMM modules. The sensor and the EEPROM are fully compliant with JEDEC JC42.4 Component Specification.

The digital temperature sensor comes with several user-programmable registers to provide maximum flexibility for temperature-sensing applications. The registers allow specifying critical, upper, and lower temperature limits as well as hysteresis settings. Both the limits and hysteresis values are used for communicating temperature events from the chip to the system. This communication is done using Event pin, which has an open-drain configuration. The user has the option of setting the Event pin polarity as either an active-low or active-high comparator output for thermostat operation, or as a temperature event interrupt output for microprocessor-based systems.

The sensor uses an industry standard 2-wire, I2C/SMBus serial interface, and allows up to eight devices to be controlled on the bus.

The 2Kbit (256 Bytes) serial EEPROM memory in the part is organized as a single block. Half the bytes in memory locations 00h to 7Fh can be permanently locked with user defined or vendor defined information. The protected data could also contain system information such as access speed, size, and organization. The 128 bytes in addresses from 80h to FFh can be used for general purpose data storage. These addresses are not write-protected.

Memory Module Temp Sensor Application

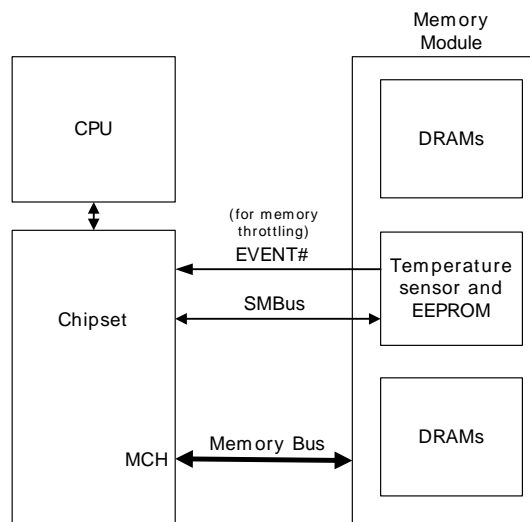

Features

- Temperature Sensor + 256 Byte Serial EEPROM
- 256 Byte Serial EEPROM for SPD
- Single Supply: 2.3V to 3.6V
- Accurate timeout support
 - Meets strict SMBus spec of 25ms (min), 35ms (max)
- Timeout supported for Temp Sensor and EEPROM
- Timeout supported in all Modes
 - Active mode for Temp sensor and EEPROM
 - EEPROM in standby or Temp sensor in shutdown
 - EEPROM in standby and Temp sensor in shutdown
- Schmitt trigger and noise filtering on bus inputs
- 2-wire Serial Interface: 10-400 kHz I2C™ /SMBus™
- Available Packages: PSON-8: DFN-8, TDFN-8

Temperature Sensor Features

- Temperature Converted to Digital Data
- Sampling Rate of 100ms (max)
- Selectable 0, 1.5°C, 3°C, 6°C Hysteresis
- Programmable Resolution from 0.0625°C to 0.5°C
- Accuracy:
 - $\pm 0.5^{\circ}\text{C} / \pm 1.0^{\circ}\text{C}$ (typ/max) from $+75^{\circ}\text{C}$ to $+95^{\circ}\text{C}$

Serial EEPROM Features

- Permanent and Reversible Software Write Protect
- Software Write Protection for the lower 128 bytes
- Byte and page write (up to 16 bytes)
- Self-time Write cycle
- Automatic address incrementing
- Organized as 1 block of 256 bytes (256x8)

Typical Applications

- DIMM Modules (DDR2, DDR3)
- Servers, Laptops, Ultra-portables, PCs, etc.
- High end audio / video equipment
- Industrial temperature monitors
- Hard Disk Drives and Other PC Peripherals

Block Diagram: Temperature Sensor with EEPROM

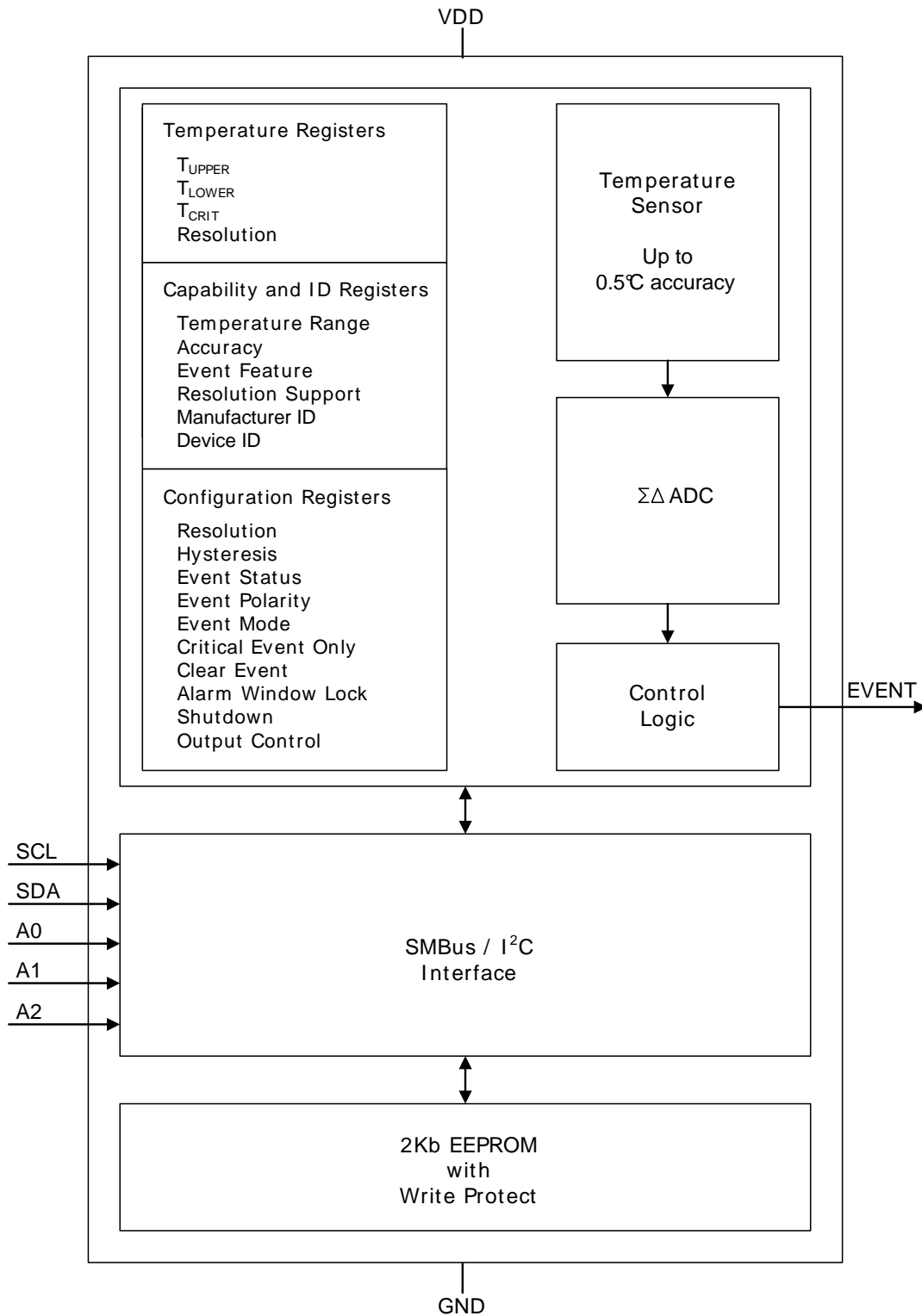

Maximum Ratings

Stressing the device above the rating listed in the Absolute Maximum Ratings table may cause permanent damage to the device. These are stress ratings only and operation of the device at these or any other conditions above those indicated in the Operating sections of this specification is not implied. Exposure to Absolute Maximum Rating conditions for extended periods may affect device reliability.

Absolute Maximum Ratings

Symbol	Parameter	Min.	Max.	Units
T_{STG}	Storage Temperature	-65	150	°C
V_{IO}	Input or output range, SA0	-0.50	10	V
	Input or output range, other pins	-0.50	4.3	V
V_{DDSPD}	Supply Voltage	-0.5	4.3	V

DC and AC Parameters

This section summarizes the operating and measurement conditions, and the DC and AC characteristics of the device. The parameters in the DC and AC Characteristic tables that follow are derived from tests performed under the Measurement Conditions summarized in the relevant tables. Designers should check that the operating conditions in their circuit match the measurement conditions when relying on the quoted parameters. DC Characteristics

Operating Conditions

Symbol	Parameter	Min.	Max.	Units
V_{DDSPD}	Supply Voltage	2.3	3.6	V
T_A	Ambient operating temperature	-20	125	°C

AC Measurement Conditions

Symbol	Parameter	Min.	Max.	Units
C_L	Load capacitance		100	pF
	Input rise and fall times		50	ns
	Input levels	0.2* V_{DDSPD} to 0.8* V_{DDSPD}		V
	Input and output timing reference levels	0.3* V_{DDSPD} to 0.7* V_{DDSPD}		V

AC Measurement I/O Waveform

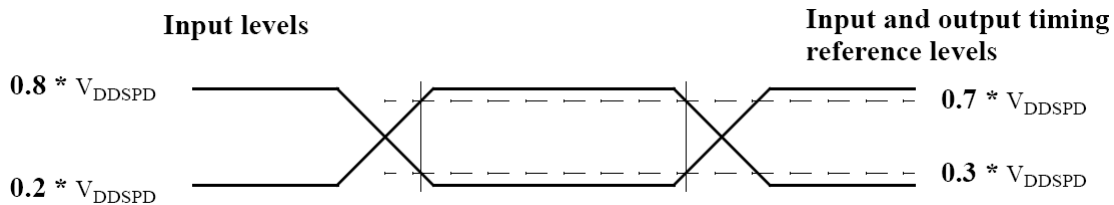

Input Parameters for the TSE2002GB2A1

Symbol	Parameter ^{1,2}	Test Condition	Min.	Max.	Units
C_{IN}	Input capacitance (SDA)			8	pF
C_{IN}	Input rise and fall times			6	ns
Z_{EIL}	Ei (SA0,SA1,SA2) input impedance	$V_{IN} < 0.3 * V_{DDSPD}$	30		k Ω
Z_{EIH}	Ei (SA0,SA1,SA2) input impedance	$V_{IN} > 0.7 * V_{DDSPD}$	800		k Ω
t_{SP}	Pulse width ignored (input filter on SCL and SDA)	Single glitch, $f \leq 100$ KHz		100	ns
		Single glitch, $f > 100$ KHz		50	

1. $T_A = 25^\circ C$, $f = 400$ kHz

2. Verified by design and characterization not necessarily tested on all devices

DC Characteristics

Parameter	Symbol	Conditions	Min.	Max.	Units
Input Leakage Current	I_{LI}	$V_{IN} = V_{SSSPD}$ or V_{DDSPD}		± 1	μA
Output Leakage Current	I_{LO}	$V_{OUT} = V_{SSSPD}$ or V_{DDSPD} , SDA in Hi-Z		± 1	μA
Supply Current	I_{DD}	$V_{DDSPD} = 3.3 V$, $f_C = 100 kHz$ (rise/fall time < 30 ns)		700	μA
Standby Supply Current	I_{DD1}	$V_{IN} = V_{SSSPD}$ or V_{DDSPD} , $V_{DDSPD} = 3.6 V$		40	μA
Input Low Voltage (SCL, SDA)	V_{IL}		-0.5	$0.3 * V_{DDSPD}$	V
Input High Voltage (SCL, SDA)	V_{IH}		$0.7 * V_{DDSPD}$	$V_{DDSPD} + 1$	V
SA0 High Voltage	V_{HV}	$V_{HV} - V_{DDSPD} \geq 4.8 V$	7	10	V
Output Low Voltage	V_{OL}	$I_{OL} = 2.1 mA$, $3 V \leq V_{DDSPD} \leq 3.6 V$		0.4	V
		$I_{OL} = 0.7 mA$, $V_{DDSPD} = 1.7 - 3.6 V$		0.2	V
Input hysteresis	V_{HYST}	$V_{DDSPD} \geq 2.2V$	$0.05 * V_{DDSPD}$	—	V

AC Characteristics

Parameter	Symbol	$V_{DDSPD} \geq 2.2 \text{ V}$		Units
		Min.	Max.	
Clock Frequency	f_{SCL}	10	400	kHz
Clock Pulse Width High Time	t_{HIGH}	600		ns
Clock Pulse Width Low Time	t_{LOW}^5	1300		ns
Detect clock low timeout, Capabilities Register bit 6 =1	$t_{TIMEOUT}^6$	25	35	ms
SDA Rise Time	t_R^2		300	ns
SDA Fall Time	t_F^2	20	300	ns
Data In Setup Time	$t_{SU:DAT}$	100		ns
Data In Hold Time	$t_{HD:DI}$	0		ns
Data Out Hold Time	$t_{HD:DAT}$	200	900	ns
Start Condition Setup Time	$t_{SU:STA}^1$	600		ns
Start Condition Hold Time	$t_{HD:STA}$	600		ns
Stop Condition Setup Time	$t_{SU:STO}$	600		ns
Time Between Stop Condition and Next Start Condition	t_{BUF}	1300		ns
Write Time	t_W		4.5	ms

1. For a RESTART condition, or following a write cycle.
2. Guaranteed by design and characterization, not necessarily tested.
3. To avoid spurious START and STOP conditions, a minimum delay is placed between falling edge of SCL and the falling or rising edge of SDA.
4. The TSE2002GB2A1 does not initiate clock stretching which is an optional I²C bus feature
5. Devices participating in a transfer can abort the transfer in progress and release the bus when any single clock low interval exceeds the value of $t_{TIMEOUT,MIN}$. After the master in a transaction detects this condition, it must generate a stop condition within or after the current data byte in the transfer process. Devices that have detected this condition must reset their communication and be able to receive a new START condition no later than $t_{TIMEOUT,MAX}$. Typical device examples include the host controller and embedded controller and most devices that can master the SMBus. Some devices do not contain a clock low drive circuit; this simple kind of device typically may reset its communications port after a start or stop condition. A timeout condition can only be ensured if the device that is forcing the timeout holds SCL low for $t_{TIMEOUT,MAX}$ or longer.
6. The temperature sensor family of devices are not required to support the SMBus ALERT function.

Temperature-to-Digital Conversion Performance

Parameter	Typ	Max	Unit	Test Conditions ¹
Temperature Sensor Accuracy	±0.5	±1.0	°C	75°C ≤ T _A ≤ 95°C
	±1.0	±2.0	°C	40°C ≤ T _A ≤ 125°C
	±2.0	±3.0	°C	-20°C ≤ T _A ≤ 125°C

1. $V_{DDSPDMIN} \leq V_{DDSPD} \leq V_{DDSPDMAX}$

Temperature Conversion Time

Resolution	ADC Setting	t _{CONV} (typ)	t _{CONV} (Max)	Unit
0.5°C	9 bit		100	ms
0.25°C (POR default)	10 bit		100	ms
0.125°C	11 bit		100	ms
0.0625°C	12 bit		100	ms

AC Waveforms

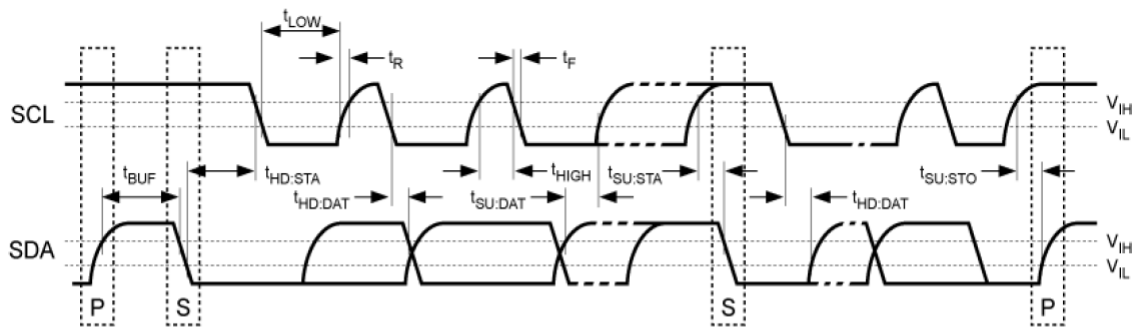

NOTE: P stands for STOP and S stands for START.

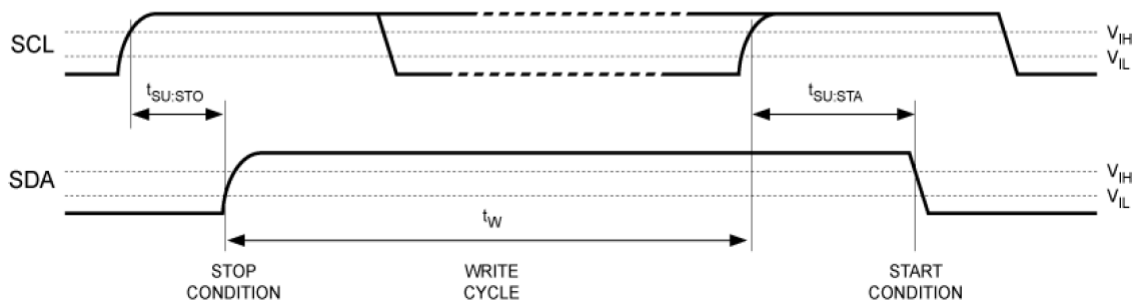

Pin Assignment

SA0	<input type="checkbox"/>	1	8	<input type="checkbox"/>	V _{DDSPD}
SA1	<input type="checkbox"/>	2	7	<input type="checkbox"/>	EVENT
SA2	<input type="checkbox"/>	3	6	<input type="checkbox"/>	SCL
V _{SSSPD}	<input type="checkbox"/>	4	5	<input type="checkbox"/>	SDA

Pin Description

Pin #	Pin Name	Definition
1	SA0	Select Address 0
2	SA1	Select Address 1
3	SA2	Select Address 2
4	V _{SSSPD}	Ground
5	SDA	Serial Data In
6	SCL	Serial Clock In
7	EVENT	Temperature Event Out
8	V _{DDSPD}	Supply Voltage

Pin Functional Descriptions

Serial Clock (SCL)

This input signal is used to strobe all data in and out of the device. In applications where this signal is used by slave devices to synchronize the bus to a slower clock, the bus master must have an open drain output, and a pull-up resistor can be connected from Serial Clock (SCL) to V_{DDSPD}. (refer to the Maximum R_L Value vs. Bus Capacitance figure on how the value of the pull-up resistor can be calculated). In most applications, though, this method of synchronization is not employed, and so the pull-up resistor is not necessary, provided that the bus master has a push-pull (rather than open drain) output.

Serial Data (SDA)

This bi-directional signal is used to transfer data in or out of the device. It is an open drain output that may be wire-ORed with other open drain or open collector signals on the bus. A pull up resistor must be connected from Serial Data (SDA) to the most positive V_{DDSPD} in the I²C chain. (refer to the Maximum R_L Value vs. Bus Capacitance figure on how the value of the pull-up resistor can be calculated).

Maximum R_L Value vs. Bus Capacitance (C_{BUS}) for an I²C Bus

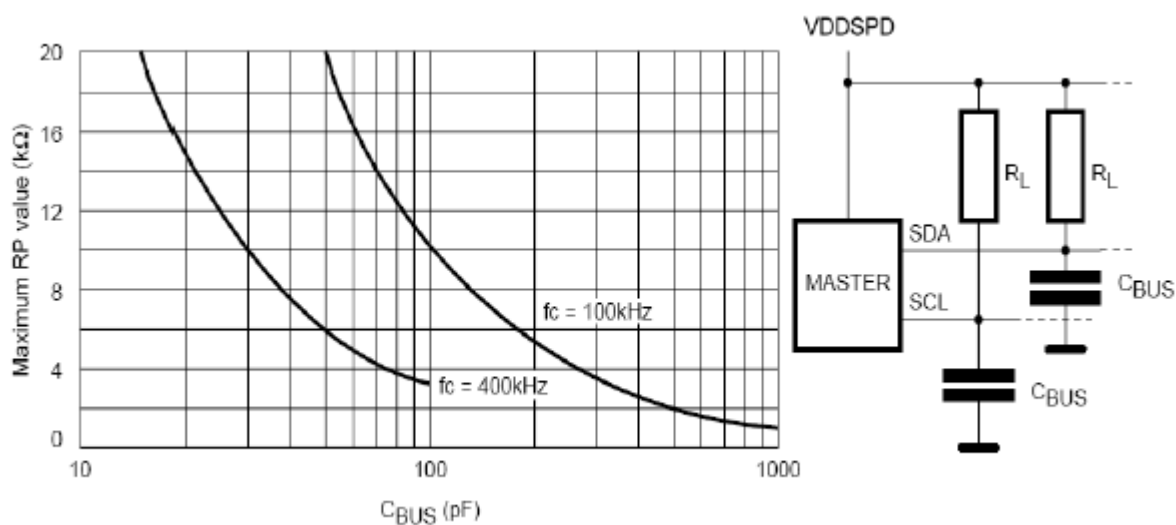

Select Address (SA0, SA1, SA2)

These input signals are used to set the value that is to be looked for on the three least significant bits (b3, b2, b1) of the 7-bit Slave Address. In the end application, SA0, SA1 and SA2 must be directly (not through a pull-up or pull-down resistor) connected to V_{DDSPD} or V_{SSSPD} to establish the Slave Address. When these inputs are not connected, an internal pull-down circuitry makes (SA0, SA1, SA2) = (0, 0, 0).

The SA0 input is used to detect the V_{HV} voltage, when decoding an SWP or CWP instruction. Refer to the I²C Operating Modes table for decoding details.

EVENT

The TSE2002GB2A1 $\overline{\text{EVENT}}$ pin is an open drain output that requires a pull-up to V_{DDSPD} on the system motherboard or integrated into the master controller. The TSE2002GB2A1 $\overline{\text{EVENT}}$ pin has three operating modes, depending on configuration settings and any current out-of-limit conditions. These modes are Interrupt, Comparator, or TCRIT Only.

In Interrupt Mode the $\overline{\text{EVENT}}$ pin will remain asserted until it is released by writing a '1' to the "Clear Event" bit in the Status Register. The value to write is independent of the $\overline{\text{EVENT}}$ polarity bit.

In Comparator Mode the $\overline{\text{EVENT}}$ pin will clear itself when the error condition that caused the pin to be asserted is removed. When the temperature is compared against the TCRIT limit, then this mode is always used.

Finally, in the TCRIT Only Mode the $\overline{\text{EVENT}}$ pin will only be asserted if the measured temperature exceeds the TCRIT Limit. Once the pin has been asserted, it will remain asserted until the temperature drops below the TCRIT Limit minus the TCRIT hysteresis. The next figure illustrates the operation of the different modes over time and temperature.

Systems that use the active high mode for $\overline{\text{EVENT}}$ must be wired point to point between the TSE2002GB2A1 and the sensing controller. Wire-OR configurations should not be used with active high $\overline{\text{EVENT}}$ since any device pulling the $\overline{\text{EVENT}}$ signal low will mask the other devices on the bus. Also note that the normal state of $\overline{\text{EVENT}}$ in active high mode is a 0 which will continually draw power through the pull-up resistor.

EVENT Pin Mode Functionality

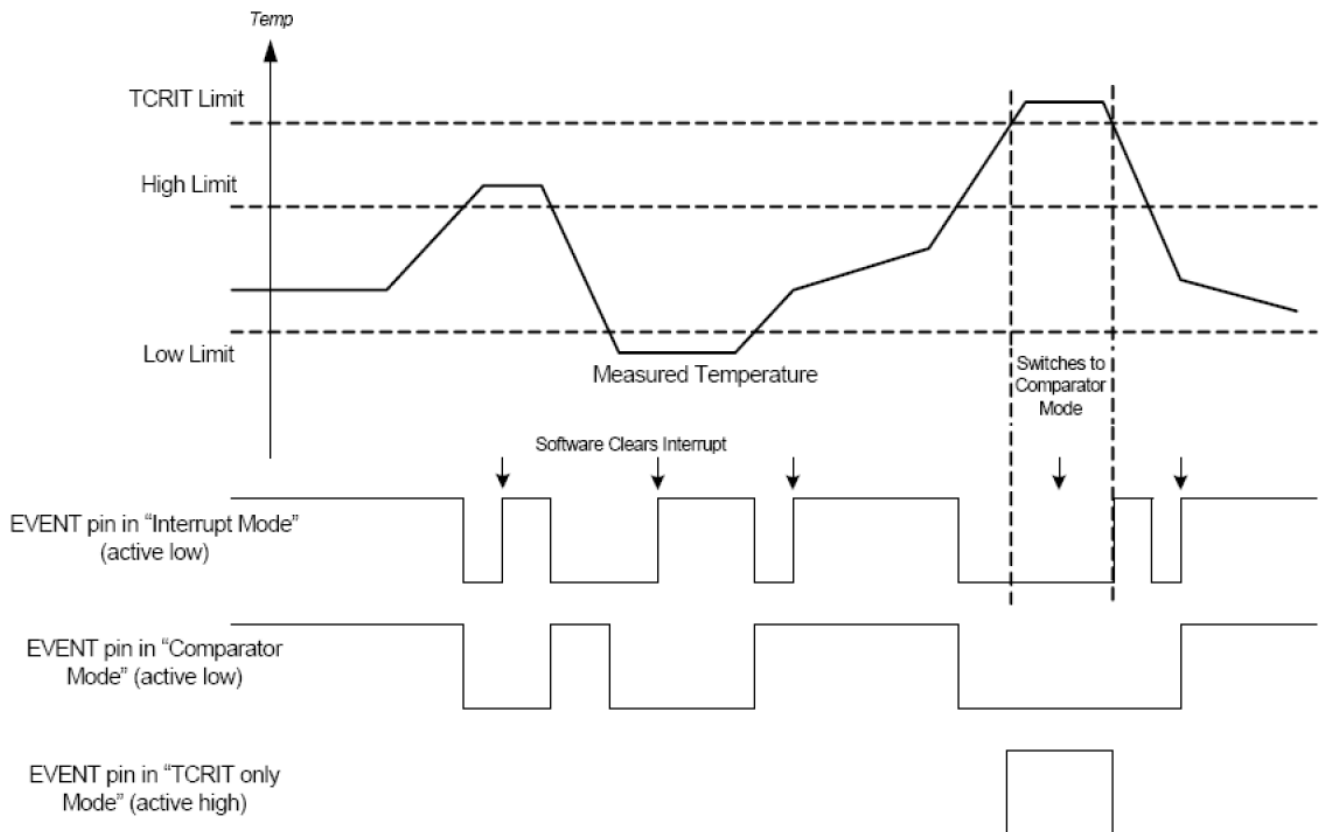

Serial Communications

The SPD section of the TSE2002GB2A1 is a 2 Kbit serial EEPROM organized as a 256 byte memory. The device is able to lock permanently the data in the lower sector (from location 0x00 to 0x7F), designed specifically for use in DRAM DIMMs (Dual Inline Memory Modules) with Serial Presence Detect. All the information concerning the DRAM module configuration (such as its access speed, its size, its organization) can be kept write protected in the first half of the memory.

Locking the lower sector of the SPD may be accomplished using one of two software write protection mechanisms. By sending the device a specific I2C sequence, the first 128 bytes of the memory become write protected, either permanently or resettable.

The TSE2002GB2A1 temperature sensor circuitry continuously monitors the temperature and updates the temperature data minimum of eight times per second. Temperature data is latched internally by the device and may be read by software from the bus host at any time.

Internal registers are used to configure both the TS performance and response to over-temperature conditions. The device contains programmable high, low, and critical temperature limits. Finally, the device $\overline{\text{EVENT}}$ pin can be configured as active high or active low and can be configured to operate as an interrupt or as a comparator output.

Device Diagram

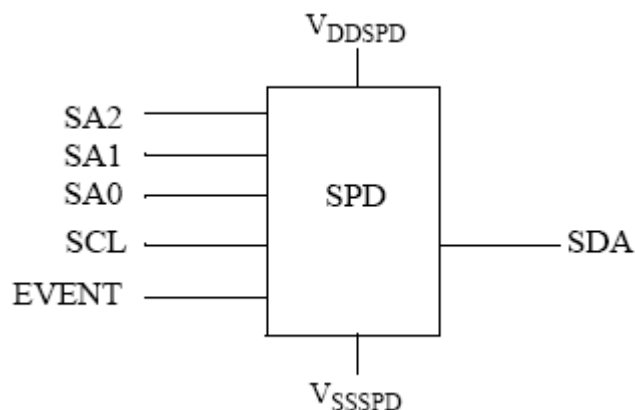

Device Interface

The TSE2002GB2A1 behaves as a slave device in the I²C protocol, with all memory operations synchronized by the serial clock. Read and Write operations are initiated by a START condition, generated by the bus master. The START condition is followed by a Device Select Code and R/W# bit (as described in the I²C Operating Mode table), terminated by an acknowledge bit. The TSE2002GB2A1 does not initiate clock stretching which is an optional I²C bus feature.

In accordance with the I²C bus definition, the device uses three (3) built-in, 4-bit Device Type Identifier Codes (DTIC) and the state of SA0, SA1, and SA2 to generate an I²C Slave Address. The SPD memory may be accessed using a DTIC of (1010), and to perform the PSWP,CSWP, or PSWP operations a DTIC of (0110) is required. The TS registers are accessed using a DTIC of (0011).

When writing data to the memory, the SPD inserts an acknowledge bit during the 9th bit time, following the bus master's 8-bit transmission. When data is read by the bus master, the bus master acknowledges the receipt of the data byte in the same way. Data transfers are terminated by a Bus Master generated STOP condition after an Ack for WRITE, and after a NoAck for READ.

The TS section of the device uses a pointer register to access all registers in the device.

Additionally, all data transfers to and from this section of the device are performed as block read/ write operations. The data is transmitted/received as 2 bytes, Most Significant Byte (MSB) first, and terminated with a NoAck and STOP after the Least Significant byte (LSB). Data and address information is transmitted and received starting with the Most Significant Bit.first

I²C Bus Protocol

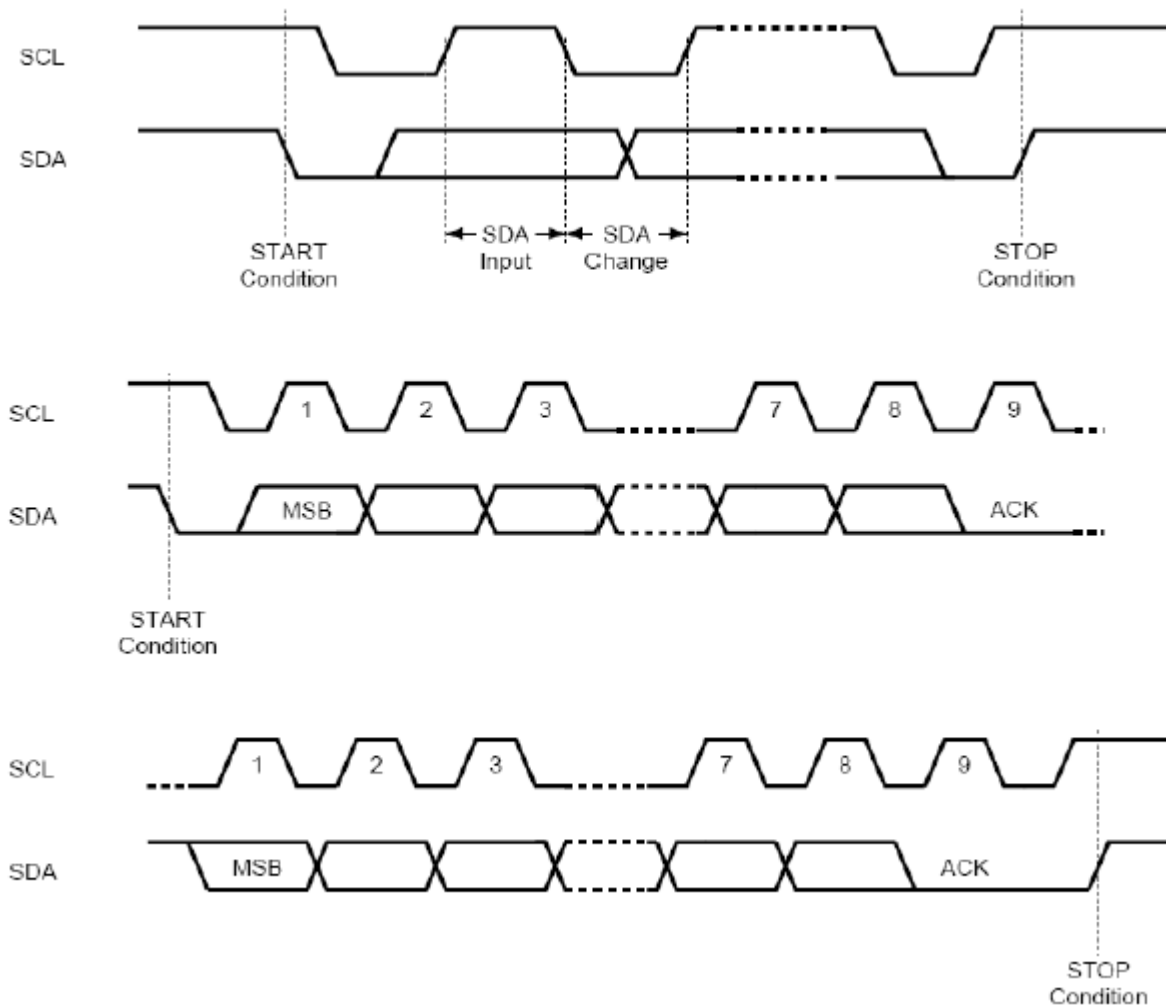

Start Condition

Start is identified by a falling edge of Serial Data (SDA) while Serial Clock (SCL) is stable in the High state. A Start condition must precede any data transfer command. The device continuously monitors (except during a Write cycle) Serial Data (SDA) and Serial Clock (SCL) for a Start condition, and will not respond unless one is given.

Stop Condition

Stop is identified by a rising edge of Serial Data (SDA) while Serial Clock (SCL) is stable and driven High. A Stop condition terminates communication between the device and the bus master. A Read command that is followed by NoAck can be followed by a Stop condition to force the SPD into Standby mode. A Stop condition at the end of a Write command triggers the internal EEPROM Write cycle for the SPD. Neither of these conditions changes the operation of the TS section.

Acknowledge Bit (ACK)

The acknowledge bit is used to indicate a successful byte transfer. The bus transmitter, whether it be bus master or slave device, releases Serial Data (SDA) after sending eight bits of data. During the 9th clock pulse period, the receiver pulls Serial Data (SDA) Low to acknowledge the receipt of the eight data bits.

No Acknowledge Bit (NACK)

The no-acknowledge bit is used to indicate the completion of a block read operation, or an attempt to modify a write-protected register. The bus master releases Serial Data (SDA) after sending eight bits of data, and during the 9th clock pulse period, and does not pull Serial Data (SDA) Low.

Data Input

During data input, the device samples Serial Data (SDA) on the rising edge of Serial Clock (SCL). For correct device operation, Serial Data (SDA) must be stable during the rising edge of Serial Clock (SCL), and the Serial Data (SDA) signal must change only when Serial Clock (SCL) is driven Low.

Memory Addressing

To start communication between the bus master and the slave device, the bus master must initiate a Start condition. Following this, the bus master sends the Device Select Code, shown in the next table (on Serial Data (SDA), most significant bit first).

Device Select Code

Memory Area Function	Device Type Identifier				Select Address Signals			R/W#
	b7 ¹	b6	b5	b4	b3	b2	b1	b0
Read/Write SPD Memory	1	0	1	0	SA2	SA1	SA0	R/W#
Set Write Protection (SWP)	0	1	1	0	V _{SSSPD}	V _{SSSPD}	V _{HV}	0
Clear Write Protection (CWP)					V _{SSSPD}	V _{DDSPD}	V _{HV}	0
Permanently Set Write Protection (PSWP) ²					SA2	SA1	SA0	0
Read SWP					V _{SSSPD}	V _{SSSPD}	V _{HV}	1
Read PSWP ²					SA2	SA1	SA0	1
Read/Write Temperature Registers	0	0	1	1	SA2	SA1	SA0	R/W#

Notes:

1. The most significant bit, b7, is sent first.
2. SA0, SA1, and SA2 are compared against the respective external pins on the TSE2002GB2A1.

The Device Select Code consists of a 4-bit Device Type Identifier, and a 3-bit Select Address (SA2, SA1, SA0). To address the memory array, the 4-bit Device Type Identifier is 1010b; to access the write-protection settings, it is 0110b; and to access the Temperature Sensor settings is 0011b.

Up to eight memory devices can be connected on a single I²C bus. Each one is given a unique 3-bit code on the Chip Enable (SA0, SA1, SA2) inputs. When the Device Select Code is received, the device only responds if the Chip Enable Address is the same as the value on the Chip Enable (SA0, SA1, SA2) inputs.

The 8th bit is the Read/Write bit (R/W#). This bit is set to 1 for Read and 0 for Write operations.

If a match occurs on the Device Select code, the corresponding device gives an acknowledgment on Serial Data (SDA) during the 9th bit time. If the device does not match the SPD Device Select code, the SPD section deselects itself from the bus, and goes into Standby mode. The I²C operating modes are shown in the following table.

I²C Operating Modes

Mode	R/W# Bit	Bytes	Initial Sequence
SPD Current Address Read	1	1	START, Device Select, R/W# = 1
SPD Random Address Read	0	1	START, Device Select, R/W# = 0, Address
	1		reSTART, Device Select, R/W# = 1
SPD Sequential Read	1	≥ 1	Similar to Current or Random Address Read
SPD Byte Write	0	1	START, Device Select, R/W# = 0, data, STOP
SPD Page Write	0	≤ 16	START, Device Select, R/W# = 0, data, STOP
TS Write	0	2	START, Device Select, R/W#=0, pointer, data, STOP
TS Read	1	2	START, Device Select, R/W#=1, pointer, data, STOP

Device Reset and Initialization

In order to prevent inadvertent Write operations during Power-up, a Power-On Reset (POR) circuit is included.

At Power-up (phase during which V_{DDSPD} is lower than $V_{DDSPDmin}$ but increases continuously), the device will not respond to any instruction until V_{DDSPD} has reached the Power On Reset threshold voltage (this threshold is lower than the minimum V_{DDSPD} operating voltage defined in the DC AND AC PARAMETERS tables). Once V_{DDSPD} has passed the POR threshold, the device is reset. The actual POR threshold voltage will be implementation dependent and is not defined in this document.

The device is delivered with all bits in the EEPROM memory array set to '1' (each byte contains 0xFF).

Prior to selecting the memory and issuing instructions, a valid and stable V_{DDSPD} voltage must be applied. This voltage must remain stable and valid until the end of the transmission of the instruction and for a Write instruction, until the completion of the internal write cycle (t_w).

At Power-down (phase during which V_{DDSPD} decreases continuously), as soon as V_{DDSPD} drops below the minimum operating voltage, the device stops responding to commands, and remains in reset until the POR threshold voltage is reached.

Software Write Protect

The TSE2002GB2A1 has three software write-protection features, allowing the bottom half of the memory area (addresses 0x00 to 0x7F) to be temporarily or permanently write protected.

Software write-protection is handled by three instructions:

SWP: Set Write Protection

CWP: Clear Write Protection

PSWP: Permanently Set Write Protection

The level of write-protection (set or cleared) that has been defined using these instructions, remains defined even after a power cycle.

Result of Setting the Write Protection

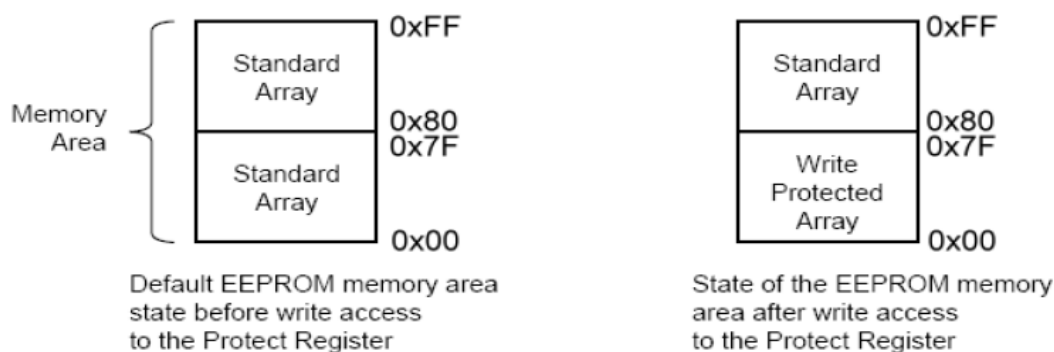

SWP and CWP

If the software write-protection has been set with the SWP instruction, it can be cleared again with a CWP instruction.

The two instructions (SWP and CWP) have the same format as a Byte Write instruction, but with a different Device Type Identifier (refer to the I²C Operating Modes table). Like the Byte Write instruction, it is followed by an address byte and a data byte, but in this case the contents are all “Don't Care” (refer to the Setting the Write Protection figure). Another difference is that the voltage, V_{HV} , must be applied on the SA0 pin, and specific logical levels must be applied on the other two (SA1 and SA2, as shown in the I²C Operating Mode table).

PSWP

If the software write-protection has been set with the PSWP instruction, the first 128 bytes of the memory are permanently write-protected. This write-protection cannot be cleared by any instruction, or by power-cycling the device. Also, once the PSWP instruction has been successfully executed, the TSE2002GB2A1 no longer acknowledges any instruction (with a Device Type Identifier of 0110) to access the write-protection settings.

Setting the Write Protection

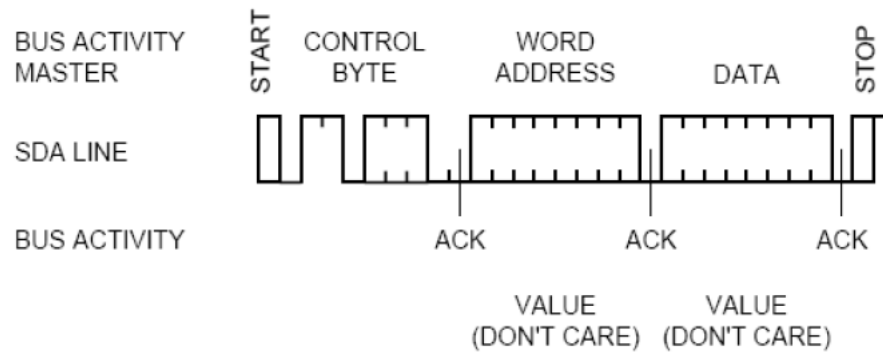

Reading Write Protection Status

The status of software write protection can be determined using these instructions:

- Read SWP: Read Write Protection Status
- Read PSWP: Read Permanently Set Write Protection Status

Read SWP

The controller issues a Read SWP command. If Software Write Protection has not been set, the device replies to the data byte with an Ack. If Software Write Protection has been set, the device replies to the data byte with a NoAck.

Read PSWP

The controller issues a Read PSWP command. If Permanent Software Write Protection has not been set, the device replies to the data byte with an Ack. If Permanent Software Write Protection has been set, the device replies to the data byte with a NoAck.

Write Operations

Following a Start condition the bus master sends a Device Select Code with the R/W# bit reset to 0. The device acknowledges this, as shown in the Write Mode Sequence in a Non-Write Protected Area figure, and waits for an address byte. The device responds to the address byte with an acknowledge bit, and then waits for the data byte.

When the bus master generates a Stop condition immediately after the Ack bit (in the "10th bit" time slot), either at the end of a Byte Write or a Page Write, the internal memory Write cycle is triggered. A Stop condition at any other time slot does not trigger the internal Write cycle.

During the internal Write cycle, Serial Data (SDA) and Serial Clock (SCL) are ignored, and the device does not respond to any requests.

Write Mode Sequences in a Non-Write Protected Area

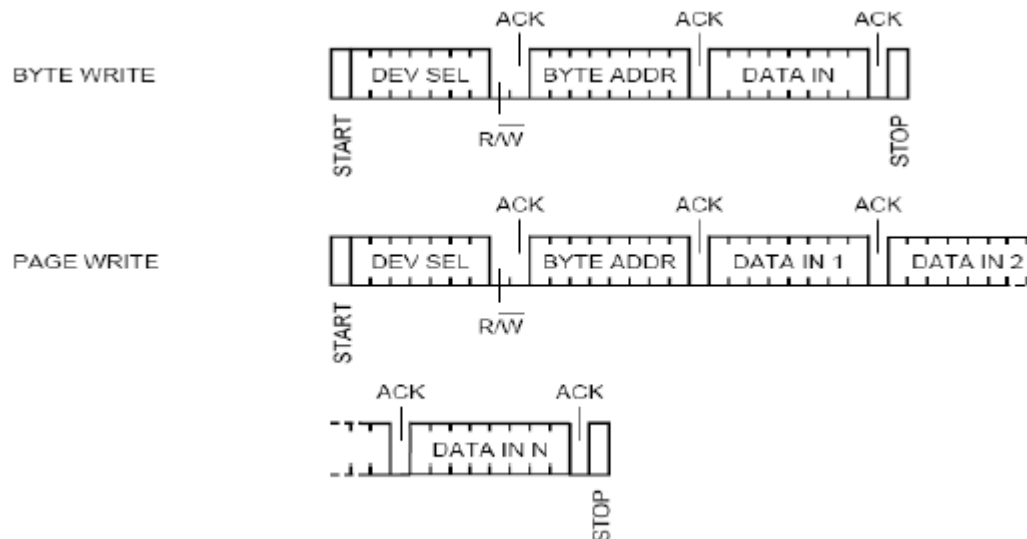

Byte Write

After the Device Select Code and the address byte, the bus master sends one data byte. If the addressed location is write-protected, the device replies to the data byte with NoAck, and the location is not modified. If, instead, the addressed location is not Write-protected, the device replies with Ack. The bus master terminates the transfer by generating a Stop condition, as shown in the Write Mode Sequence in a Non-Write Protected Area figure above.

Page Write

The Page Write mode allows up to 16 bytes to be written in a single Write cycle, provided that they are all located in the same page in the memory: that is, the most significant memory address bits are the same. If more bytes are sent than will fit up to the end of the page, a condition known as “roll-over” occurs. This should be avoided, as data starts to be over-written in an implementation dependent fashion.

The bus master sends from 1 to 16 bytes of data, each of which is acknowledged by the device. If the addressed location is write-protected, the device replies to the data byte with NoAck, and the locations are not modified. After each byte is transferred, the internal byte address counter is incremented. The transfer is terminated by the bus master generating a Stop condition.

Write Cycle Polling Using ACK

During the internal Write cycle, the device disconnects itself from the bus, and writes a copy of the data from its internal latches to the memory cells. The maximum Write time (t_W) is shown in the AC Characteristic for TSE2002GB2A1 table, but the typical time is shorter. To make use of this, a polling sequence can be used by the bus master.

The polling sequence is shown in the following figure:

- Initial condition: a Write cycle is in progress.
- Step 1: the bus master issues a Start condition followed by a Device Select Code (the first byte of the new instruction).
- Step 2: if the device is busy with the internal Write cycle, no Ack will be returned and the bus master goes back to Step 1. If the device has terminated the internal Write cycle, it responds with an Ack, indicating that the device is ready to receive the second part of the instruction (the first byte of this instruction having been sent during Step 1).

Write Cycle Polling Flowchart Using ACK

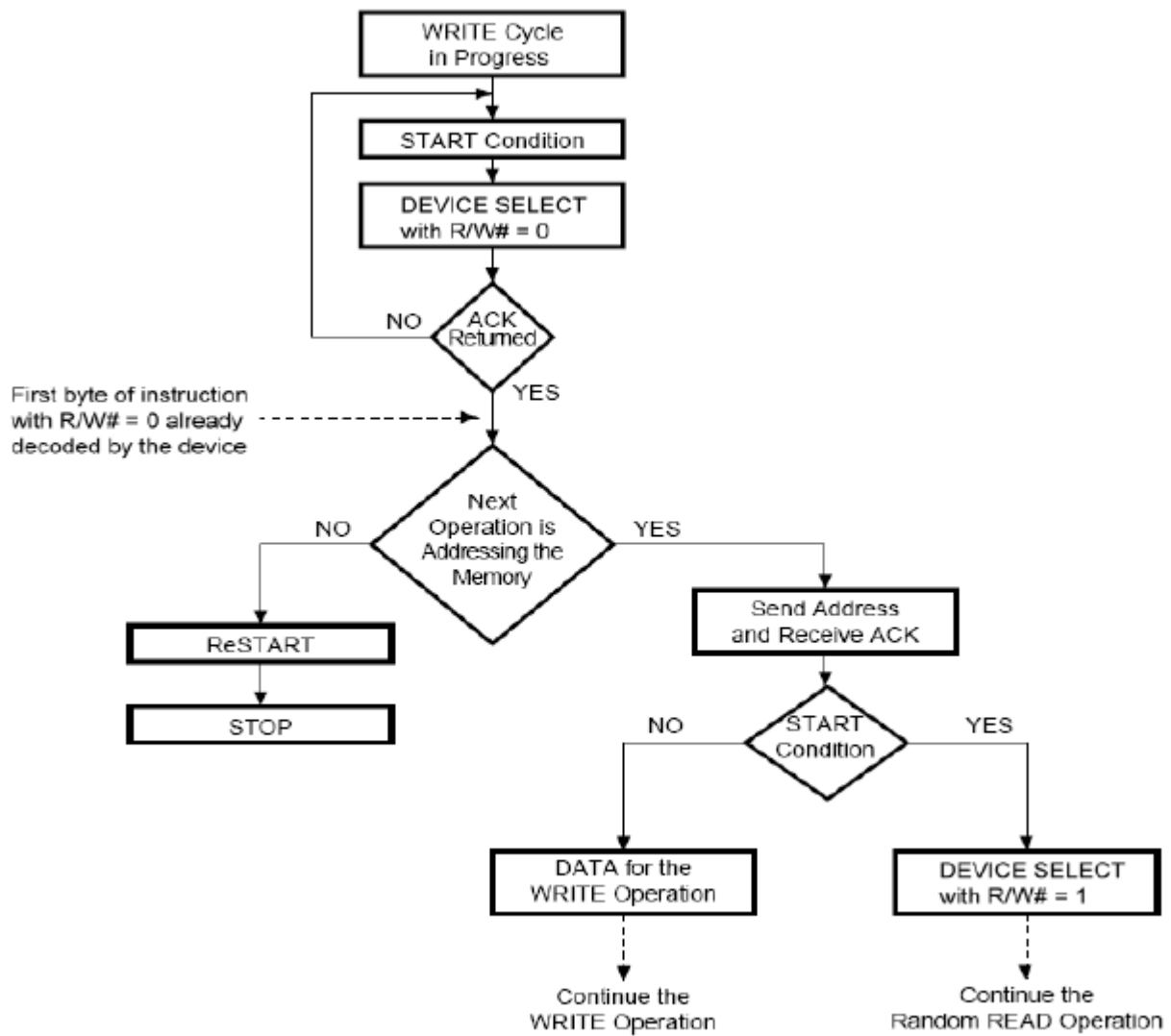

Read Operations

Read operations are performed independent of the software protection state. The device has an internal address counter which is incremented each time a byte is read.

Read Mode Sequences

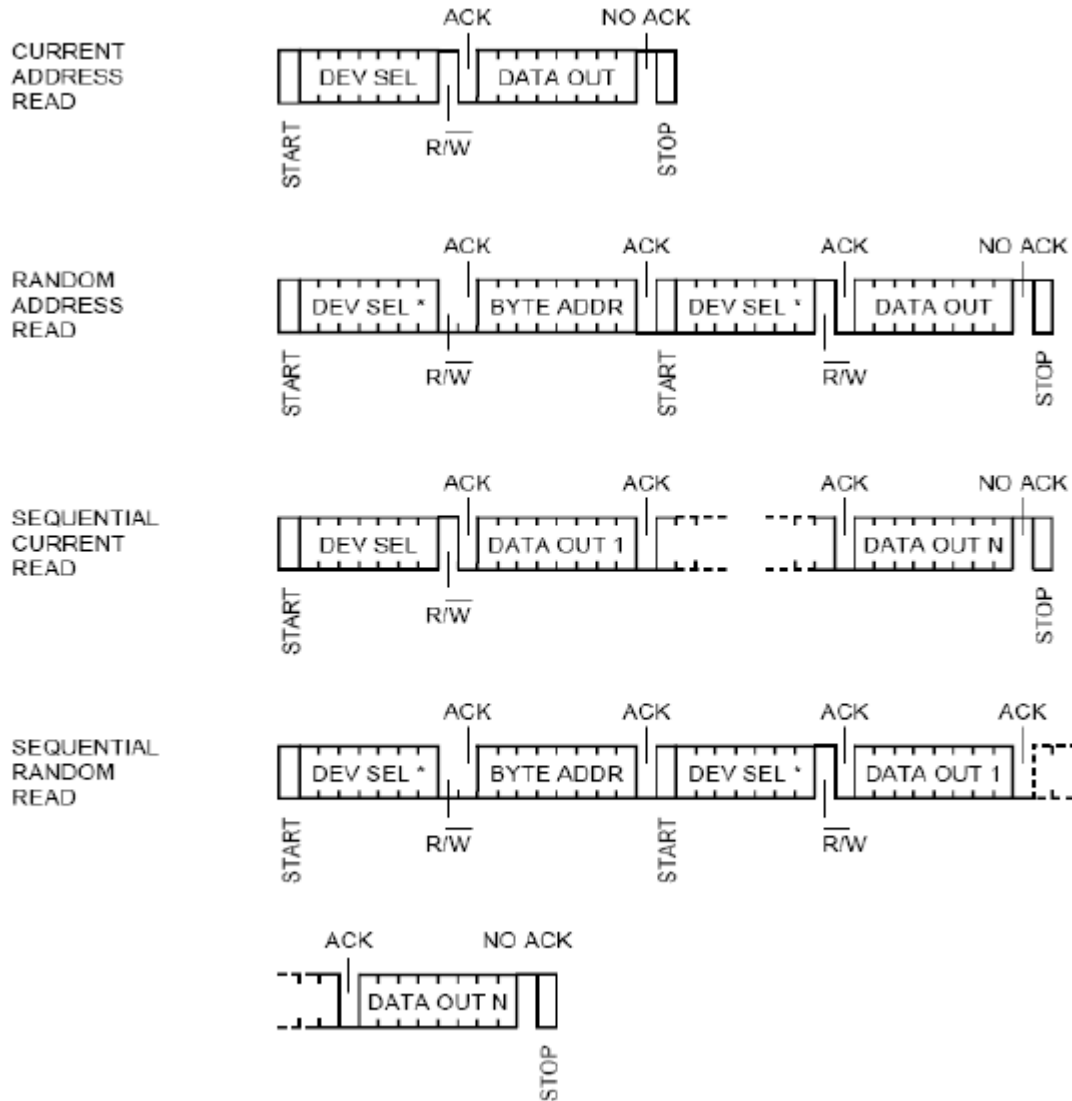

Random Address Read

A dummy Write is first performed to load the address into this address counter (refer to the Read Mode Sequence figure) but without sending a Stop condition. Then, the bus master sends another Start condition, and repeats the Device Select Code, with the R/W# bit set to 1. The device acknowledges this, and outputs the contents of the addressed byte. The bus master must not acknowledge the byte, and terminates the transfer with a Stop condition.

Current Address Read

For the Current Address Read operation, following a Start condition, the bus master only sends a Device Select Code with the R/W# bit set to 1. The device acknowledges this, and outputs the byte addressed by the internal address counter. The counter is then incremented. The bus master terminates the transfer with a Stop condition, as shown in the Read Mode Sequence figure, without acknowledging the byte.

Sequential Read

This operation can be used after a Current Address Read or a Random Address Read. The bus master does acknowledge the data byte output, and sends additional clock pulses so that the device continues to output the next byte in sequence. To terminate the stream of bytes, the bus master must not acknowledge the last byte, and must generate a Stop condition (refer to the Read Mode Sequence figure). The output data comes from consecutive addresses, with the internal address counter automatically incremented after each byte output. After the last memory address, the address counter 'rolls-over', and the device continues to output data from memory address 0x00.

Acknowledge in Read Mode

For all Read commands to the SPD, the device waits, after each byte read, for an acknowledgment during the 9th bit time. If the bus master does not drive Serial Data (SDA) Low during this time, the device terminates the data transfer and returns to an idle state to await the next valid START condition. This has no effect on the TS operational status.

Acknowledge When Writing Data or Defining Write Protection (Instructions with R/W# Bit=0)

Status	Instruction	ACK	Address	ACK	Data Byte	ACK	Write Cycle (t _w)
Permanently Protected	PSWP, SWP, or CWP	NoACK	Not Significant	NoACK	Not Significant	NoACK	No
	Page or byte write in lower 128 bytes	ACK	Address	ACK	Data	ACK or NoACK ¹	Yes
Protected with SWP	SWP	NoACK	Not Significant	NoACK	Not Significant	NoACK	No
	CWP	ACK	Not Significant	ACK	Not Significant	ACK	Yes
	PSWP	ACK	Not Significant	ACK	Not Significant	ACK	Yes
	Page or byte write in lower 128 bytes	ACK	Address	ACK	Data	ACK or NoACK ¹	Yes
Not Protected	PSWP, SWP, or CWP	ACK	Not Significant	ACK	Not Significant	ACK	Yes
	Page or byte write	ACK	Address	ACK	Data	ACK	Yes

Note 1: Software must accept either return code.

Acknowledge When Reading the Write Protection (Instructions with R/W# Bit=1)

PSWP Status	SWP Status	Instruction	ACK	Address	ACK	Data Byte	ACK
Set	X	Read PSWP	NoACK	Not Significant	NoACK	Not Significant	NoACK
Not Set	X	Read PSWP	ACK	Not Significant	NoACK	Not Significant	NoACK
Set	X	Read SWP	NoACK	Not Significant	NoACK	Not Significant	NoACK
X	Set	Read SWP	NoACK	Not Significant	NoACK	Not Significant	NoACK
Not Set	Not Set	Read SWP	ACK	Not Significant	NoACK	Not Significant	NoACK

Note: X = Set or Not Set.

Temperature Sensor (TS) Device Operation

The TSE2002GB2A1 Temperature Register Set is accessed through the I²C address 0011_bbb_R/W#. The "bbb" denotes the current state of SA2, SA1, and SA0. In the event SA0 is in the high voltage state, the device interprets the voltage as a logic '1' at the pin. The Temperature Register Set stores the temperature data, limits, and configuration values. All registers in the address space from 0x00 through 0x08 are 16-bit registers accessed through block read and write commands as detailed in the TS Write Operation section.

TS Write Operations

Writing to the TSE2002GB2A1 Temperature Register Set is accomplished through a modified block write operation for two (2) data bytes. To maintain I²C compatibility, the 16 bit register is accessed through a pointer register, requiring the write sequence to include an address pointer in addition to the Slave address. This indicates the storage location for the next two bytes received. The next figure shows an entire write transaction on the bus.

TS Register Write Operation

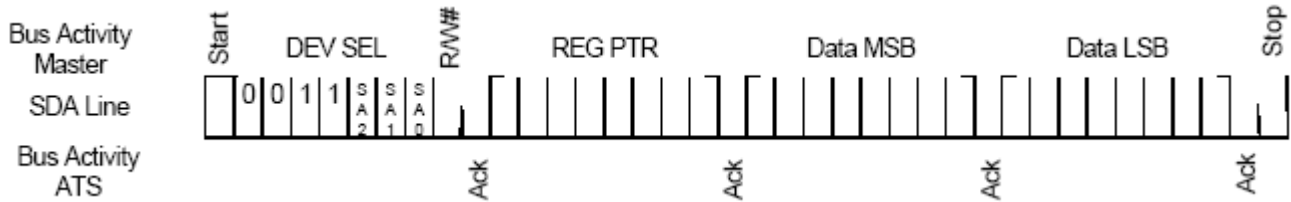

TS Read Operations

Reading data from the TS may be accomplished in one of two ways:

1. If the location latched in the Pointer Register is correct (for normal operation it is expected the same address will be read repeatedly for temperature), the read sequence may consist of a Slave Address from the bus master followed by two bytes of data from the device; or
2. The pointer register is loaded with the correct register address, and the data is read. The sequence to preset the pointer register is shown in the I²C Write to Pointer Register figure, and the preset pointer read is shown in the I²C Preset Pointer Register Word Read figure. If it is desired to read random address each cycle, the complete Pointer Write, Word Read sequence is shown in the I²C Pointer Write Register Word Read figure.

The data byte has the most significant bit first. At the end of a read, this device can accept either Acknowledge (Ack) or No Acknowledge (No Ack) from the Master (No Acknowledge is typically used as a signal for the slave that the Master has read its last byte).

I²C Write to Pointer Register

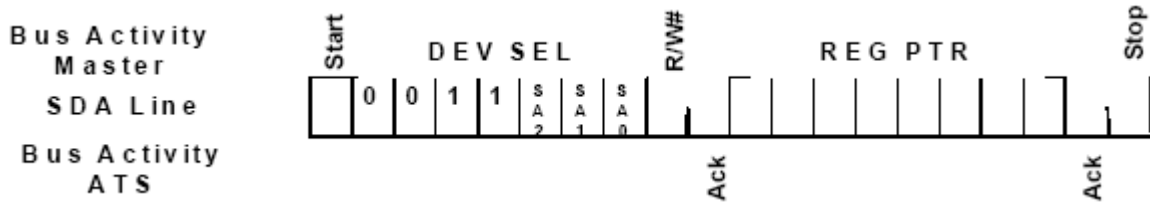

I²C Preset Pointer Register Word Read

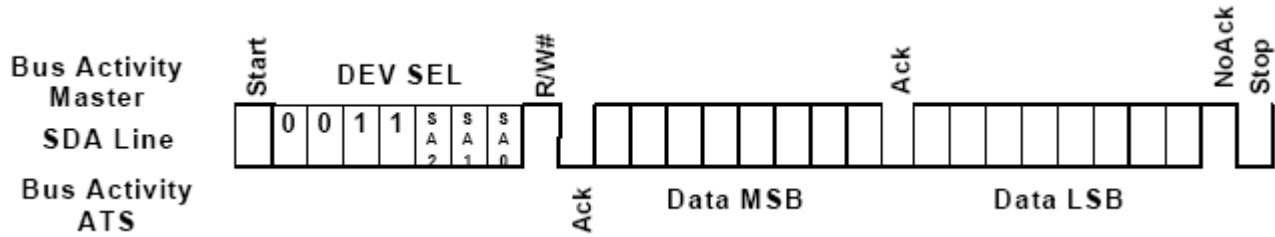

I²C Pointer Write Register Word Read

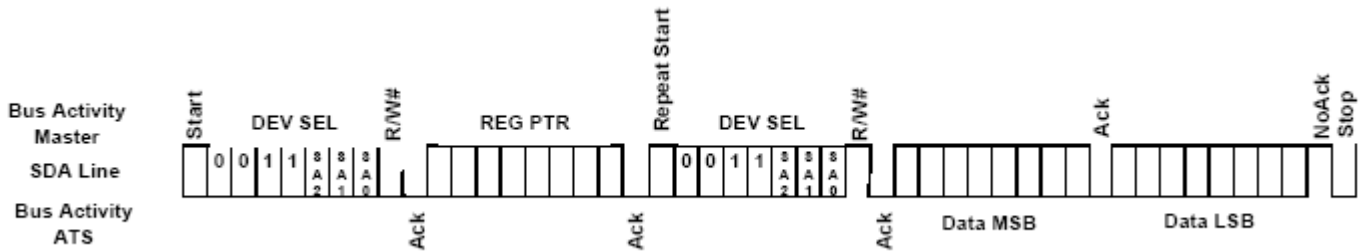

TS Register Set Definition

The register set address are shown in the Acknowledge When Writing Data or Defining Write Protection table. These values are used in the I²C operations as the "REG_PTR" as shown in previous three figures.

Temperature Register Addresses

ADDR	R/W	Name	Function	Default
N/A	W	Address Pointer	Address storage for subsequent operations	N/A
00	R	Capabilities	Indicates the functions and capabilities of the temperature sensor	006F
01	R/W	Configuration	Controls the operation of the temperature monitor	0000
02	R/W	High Limit	Temperature High Limit	0000
03	R/W	Low Limit	Temperature Low Limit	0000
04	R/W	TCRIT Limit	Critical Temperature	0000
05	R	Ambient Temperature	Current Ambient temperature	N/A
06	R	Manufacturer ID	PCI-SIG manufacturer ID	00B3
07	R	Device/Revision	Device ID and Revision number	2912
08	R/W	Resolution Register	Allows changing temperature sensor resolution	002F

Capabilities Register

The Capabilities Register indicates the supported features of the temperature sensor.

Capabilities Register

ADDR	R/W	B15/B7	B14/B6	B13/B5	B12/B4	B11/B3	B10/B2	B9/B1	B8/B0	Default
00	R	RFU	RFU	RFU	RFU	RFU	RFU	RFU	RFU	006F
		EVSD	TMOU	X	TRES[1:0]		RANGE	ACC	$\overline{\text{EVENT}}$	

Bits 15 - Bit 8 – RFU; Reserved for future use. These bits will always read '0' and writing to them will have no affect.

Bit 7- EVSD-EVENT with Shutdown action.

'0' - (default) The $\overline{\text{EVENT}}$ output freezes in its current state when entering shutdown. Upon exiting shutdown, the $\overline{\text{EVENT}}$ output remains in the previous state until the next thermal sample is taken, or possibly sooner if EVENT is programmed for comparator mode.

'1' The $\overline{\text{EVENT}}$ output is deasserted (not driven) when entering shutdown and remains deasserted upon exit from shutdown until the next thermal sample is taken, or possibly sooner if EVENT is programmed for comparator mode.

Bit 6 - TMOU – Bus timeout period for thermal sensor access during normal operation. Note that the TSE2002GB2A1 supports timeout in both active and shutdown mode for temperature sensor and SPD (EEPROM) portions of the device.

'0' - Parameter t_{TIMEOUT} is supported within the range of 10 to 60 ms.

'1' - (default) Parameter t_{TIMEOUT} is supported within the range of 25 to 35 ms (SMBus compatible).

Bit 5 - X – May be 0 or 1; applications must accept either code. (Default =1)

Bits 4 - 3 – TRES[1:0]; Indicates the resolution of the temperature monitor as shown in the TRES Bit Decode table. (Default =01)

TRES Bit Decode

TRES[1:0]		Temperature Resolution
1	0	
0	0	0.5°C (9-bit)
0	1	0.25°C (10-bit) (default)
1	0	0.125°C (11-bit)
1	1	0.0625°C (12-bit)

Note: Refer to section Resolution Register on page 28.

Bit 2 - RANGE; Indicates the supported temperature range.

'0' - The temperature monitor clamps values lower than 0 °C.

'1' (default) - The temperature monitor can read temperatures below 0 °C and sets the sign bit appropriately.

Bit 1 - ACC; Indicates the supported temperature accuracy.

'0' - The temperature monitor has ±2 °C accuracy of the active range (75 °C to 95 °C) and 3 °C accuracy over the entire operating range.

'1' (default) - Bgrade. The temperature monitor has ±1 °C accuracy over the active range (75 °C to 95 °C) and 2°C accuracy over the monitoring range (40 °C to 125 °C)

Bit 0 - $\overline{\text{EVENT}}$; Indicates whether the temperature monitor supports interrupt capabilities

'0'.-The device does not support interrupt capabilities.

'1' (default); The device supports interrupt capabilities.

Configuration Register

Configuration Register

ADDR	R/W	B15/B7	B14/B6	B13/B5	B12/B4	B11/B3	B10/B2	B9/B1	B8/B0	Default
01	R/W	RFU	RFU	RFU	RFU	RFU	HYST[1:0]		SHDN	0000
		TCRIT_ LOCK	EVENT_ LOCK	CLEAR	EVENT_ STS	EVENT_ CTRL	TCRIT_ ONLY	EVENT_ POL	EVENT_ MODE	

The Configuration Register holds the control and status bits of the EVENT pin as well as general hysteresis on all limits.

Bits 15 - 11 – RFU; Reserved for future use. These bits will always read '0' and writing to them will have no affect. For future compatibility, all RFU bits must be programmed as '0'.

Bits 10 - 9 – HYST[1:0]; Control the hysteresis that is applied to all limits as shown in the HYST Bit Decode table that follows. This hysteresis applies to all limits when the temperature is dropping below the threshold so that once the temperature is above a given threshold, it must drop below the threshold minus the hysteresis in order to be flagged as an interrupt event. Note that hysteresis is also applied to $\overline{\text{EVENT}}$ pin functionality. When either of the lock bits is set, these bits cannot be altered.

HYST Bit Decode

HYST[1:0]		Hysteresis
1	0	
0	0	Disable hysteresis (default)
0	1	1.5°C
1	0	3°C
1	1	6°C

Bit 8 – SHDN-Shutdown. The thermal sensing device and A/D converters are disabled to save power, no events will be generated. When either of the lock bits is set, this bit cannot be set until unlocked. However it can be cleared at any time. When in shutdown mode, the TSE2002GB2A1 still responds to commands normally, however bus timeout may or may not be supported in this mode.

'0' (default); The temperature monitor is active and converting

'1'; The temperature monitor is disabled and will not generate interrupts or update the temperature data.

Bit 7 – TCRIT_LOCK; Locks the TCRIT Limit Register from being updated.

'0' (default); The TCRIT Limit Register can be updated normally.

'1'; The TCRIT Limit Register is locked and cannot be updated. Once this bit has been set, it cannot be cleared until an internal power on reset.

Bit 6 – EVENT_LOCK; Locks the High and Low Limit Registers from being updated.

'0' (default); The High and Low Limit Registers can be updated normally.

'1'; The High and Low Limit Registers are locked and cannot be updated. Once this bit has been set, it cannot be cleared until an internal power on reset.

Bit 5 – CLEAR; Clears the EVENT pin when it has been asserted. This bit is write only and will always read '0'.

'0'; does nothing

'1'; The $\overline{\text{EVENT}}$ pin is released and will not be asserted until a new interrupt condition occurs. This bit is ignored if the device is operating in Comparator Mode. This bit is self clearing.

Bit 4 – EVENT_STS; Indicates if the $\overline{\text{EVENT}}$ pin is asserted. This bit is read only.

'0' (default); The EVENT pin is not asserted.

'1'; The $\overline{\text{EVENT}}$ pin is being asserted by the device.

Bit 3 – EVENT_CTRL; Masks the $\overline{\text{EVENT}}$ pin from generating an interrupt. If either of the lock bits are set (bit 7 and bit 6), then this bit cannot be altered.

'0' (default); The $\overline{\text{EVENT}}$ pin is disabled and will not generate interrupts.

'1'; The EVENT pin is enabled.

Bit 2 – TCRIT_ONLY; Controls whether the $\overline{\text{EVENT}}$ pin will be asserted from a high / low out-of-limit condition. When the EVENT_LOCK bit is set, this bit cannot be altered.

'0' (default); The $\overline{\text{EVENT}}$ pin will be asserted if the measured temperature is above the High Limit or below the Low Limit in addition to if the temperature is above the TCRIT Limit.

'1'; The $\overline{\text{EVENT}}$ pin will only be asserted if the measured temperature is above the TCRIT Limit.

Bit 1 – EVENT_POL; Controls the “active” state of the $\overline{\text{EVENT}}$ pin. The $\overline{\text{EVENT}}$ pin is driven to this state when it is asserted.

Advance Information

'0' (default); The $\overline{\text{EVENT}}$ pin is active low. The “active” state of the pin will be logical '0'.

'1'; The $\overline{\text{EVENT}}$ pin is active high. The “active” state of the pin will be logical '1'.

Bit 0 – EVENT_MODE; Controls the behavior of the $\overline{\text{EVENT}}$ pin. The $\overline{\text{EVENT}}$ pin may function in either comparator or interrupt mode.

'0'; The $\overline{\text{EVENT}}$ pin will function in comparator mode.

'1'; The $\overline{\text{EVENT}}$ pin will function in interrupt mode.

Temperature Register Value Definitions

Temperatures in the High Limit Register, Low Limit Register, TCRIT Register, and Temperature Data Register are expressed in two's complement format. Bits B 12 through B2 for each of these registers are defined for all device resolutions as defined in the TRES field of the Capabilities Register, hence a 0.25°C minimum granularity is supported in all registers. Examples of valid settings and interpretation of temperature register bits:

Temperature Register Coding Examples		
B15~B0 (binary)	Value	Units
xxx0 0000 0010 11xx	+2.75	°C
xxx0 0000 0001 00xx	+1.00	°C
xxx0 0000 0000 01xx	+0.25	°C
xxx0 0000 0000 00xx	0	°C
xxx1 1111 1111 11xx	-0.25	°C
xxx1 1111 1111 00xx	-1.00	°C
xxx1 1111 1101 01xx	-2.75	°C

The TRES field of the Capabilities Register optionally defines higher resolution devices. For compatibility and simplicity, this additional resolution affects only the Temperature Data Register but none of the Limit Registers. When higher resolution devices generate status or $\overline{\text{EVENT}}$ changes, only bits B12 through B2 are used in the comparison; however, all 11 bits (TRES[1-0] = 10) or all 12 bits (TRES[1-0] = 11) are visible in reads from the Temperature Data Register.

When a lower resolution device is indicated in the Capabilities Register (TRES[1-0] = 00), the finest resolution supported is 0.5°C. When this is detected, bit 2 of all Limit Registers should be programmed to 0 to assure correct operation of the temperature comparators.

High Limit Register

The temperature limit registers (High, Low, and TCRIT) define the temperatures to be used by various on-chip comparators to determine device temperature status and thermal EVENTS. For future compatibility, unused bits “-” must be programmed as 0.

High Limit Register

ADDR	R/W	B15/B7	B14/B6	B13/B5	B12/B4	B11/B3	B10/B2	B9/B1	B8/B0	Default
02	R/W	–	–	–	Sign	128	64	32	16	0000
		8	4	2	1	0.5	0.25	–	–	

The High Limit Register holds the High Limit for the nominal operating window. When the temperature rises above the High Limit, or drops below or equal to the High Limit, then the $\overline{\text{EVENT}}$ pin is asserted (if enabled). If the EVENT_LOCK bit is set as shown in the Configuration Register table, then this register becomes read-only.

Low Limit Register

Low Limit Register

ADDR	R/W	B15/B7	B14/B6	B13/B5	B12/B4	B11/B3	B10/B2	B9/B1	B8/B0	Default
03	R/W	–	–	–	Sign	128	64	32	16	0000
		8	4	2	1	0.5	0.25	–	–	

The Low Limit Register holds the lower limit for the nominal operating window. When the temperature drops below the Low Limit or rises up to meet or exceed the Low Limit, then the $\overline{\text{EVENT}}$ pin is asserted (if enabled). If the `EVENT_LOCK` bit is set as shown in the Configuration Register, then this register becomes read-only.

TCRIT Limit Register

TCRIT Limit Register

ADDR	R/W	B15/B7	B14/B6	B13/B5	B12/B4	B11/B3	B10/B2	B9/B1	B8/B0	Default
04	R/W	–	–	–	Sign	128	64	32	16	0000
		8	4	2	1	0.5	0.25	–	–	

The TCRIT Limit Register holds the TCRIT Limit. If the temperature exceeds the limit, the $\overline{\text{EVENT}}$ pin will be asserted. It will remain asserted until the temperature drops below or equal to the limit minus hysteresis. If the `TCRIT_LOCK` bit is set as shown in the Configuration Register table, then this register becomes read-only.

Temperature Data Register

Temperature Data Register

ADDR	R/W	B15/B7	B14/B6	B13/B5	B12/B4	B11/B3	B10/B2	B9/B1	B8/B0	Default
05	R	TCRIT	HIGH	LOW	Sign	128	64	32	16	N/A (0000)
		8	4	2	1	0.5	0.25*	0.125*	0.0625*	

* Resolution defined based on value of `TRES` field of the Capabilities Register. Unused/unsupported bits will read as 0.

The Temperature Data Register holds the 10-bit + sign data for the internal temperature measurement as well as the status bits indicating which error conditions, if any, are active. The encoding of bits B 12 through B0 is the same as for the temperature limit registers.

Bit 15 – TCRIT; When set, the temperature is above the TCRIT Limit. This bit will remain set so long as the temperature is above TCRIT and will automatically clear once the temperature has dropped below the limit minus the hysteresis.

Bit 14 – HIGH; When set, the temperature is above the High Limit. This bit will remain set so long as the temperature is above the HIGH limit. Once set, it will only be cleared when the temperature drops below or equal to the HIGH Limit minus the hysteresis.

Bit 13 – LOW; When set, the temperature is below the Low Limit. This bit will remain set so long as the temperature is below the Low Limit minus the hysteresis. Once set, it will only be cleared when the temperature meets or exceeds the Low Limit.

Manufacturer ID Register**Manufacturer ID Register**

ADDR	R/W	B15/B7	B14/B6	B13/B5	B12/B4	B11/B3	B10/B2	B9/B1	B8/B0	Default
06	R/W	0	0	0	0	0	0	0	0	00B3
		1	0	1	1	0	0	1	1	

The Manufacturer ID Register holds the PCI SIG number assigned to the specific manufacturer.

Device ID/Revision Register**Device ID/Revision Register**

ADDR	R/W	B15/B7	B14/B6	B13/B5	B12/B4	B11/B3	B10/B2	B9/B1	B8/B0	Default
07	R/W	0	0	1	0	1	0	0	1	2912
		0	0	0	1	0	0	1	0	

The upper byte of the Device ID / Revision Register stores a unique number indicating the TSE2002GB2A1 from other devices. The lower byte holds the revision value.

Resolution Register

This register allows the user to change the resolution of the temperature sensor. The POR default resolution is 0.25°C. The resolution implemented via this register is also reflected in the capability register.

Resolution Register

ADDR	R/W	B15/B7	B14/B6	B13/B5	B12/B4	B11/B3	B10/B2	B9/B1	B8/B0	Default Value
08h	R/W	0	0	0	0	0	0	0	0	002F
		0	0	1	TRES[1]	TRES[0]	1	1	1	

Legend:

Resolution bits 4-3 TRES[4:3]

00 = LSB = 0.5°C (register value = 0007)

01 = LSB = 0.25°C (register value = 000F)

10 = LSB = 0.125°C (register value = 0017)

11 = LSB = 0.0625°C (register value = 001F)

Conversion times for each resolution are less than 100ms (worst case).

Use in a Memory Module

In the Dual Inline Memory Module (DIMM) application, the TSE2002GB2A1 is soldered directly onto the printed circuit module. The three Select Address inputs (SA0, SA1, SA2) must be connected to V_{SSSPD} or V_{DDSPD} directly (that is without using a pull-up or pull-down resistor) through the DIMM socket (as shown in the Unique Addressing table). The pull-up resistors needed for normal behavior of the I²C bus are connected on the I²C bus of the mother-board

Unique Addressing of SPDs in DIMM Applications

DIMM Position	SA2	SA1	SA0
0	0	0	0
1	0	0	1
2	0	1	0
3	0	1	1
4	1	0	0
5	1	0	1
6	1	1	0
7	1	1	1

Note: 0 = V_{SSSPD} , 1 = V_{DDSPD} .

The Event pin is expected to be used in a wire-OR configuration with a pull-up resistor to V_{DDSPD} on the motherboard. In this configuration, EVENT should be programmed for the active low mode. Also note that comparator mode or TCRIT-only mode for EVENT on a wire-OR bus will show the combined results of all devices wired to the EVENT signal.

Programming the TSE2002GB2A1

The situations in which the TSE2002GB2A1 is programmed can be considered under two headings:

- When the DIMM is isolated (not inserted on the PCB motherboard)
- When the DIMM is inserted on the PCB motherboard

DIMM Isolated

With specific programming equipment, it is possible to define the TSE2002GB2A1 content, using Byte and Page Write instructions, and its write-protection using the SWP and CWP instructions. To issue the SWP and CWP instructions, the DIMM must be inserted in the application-specific slot where the SA0 signal can be driven to V_{HV} during the whole instruction. This programming step is mainly intended for use by DIMM makers, whose end application manufacturers will want to clear this write-protection with the CWP on their own specific programming equipment, to modify the lower 128 Bytes, and finally to set permanently the write-protection with the PSWP instruction.

DIMM Inserted in the Application Mother Board

As the final application cannot drive the SA0 pin to V_{HV} , the only possible action is to freeze the write-protection with the PSWP instruction. Refer to the Acknowledge When Writing Data or Defining Write Protection table on how the Ack bits can be used to identify the write-protection status.

Ordering Information

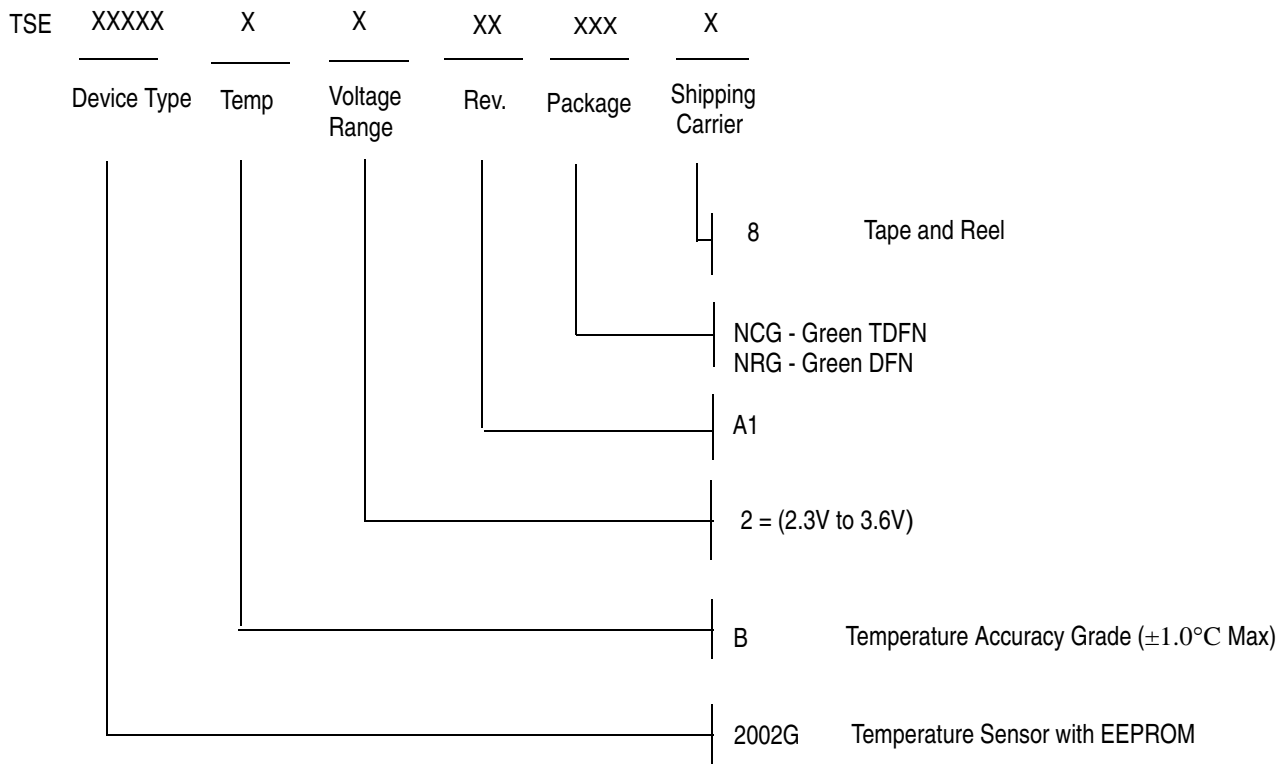

Example: TSE2002GB2A1 NRG8



CORPORATE HEADQUARTERS
6024 Silver Creek Valley Road
San Jose, CA 95138

for SALES:
800-345-7015 or 408-284-8200
fax: 408-284-2775
www.idt.com

for Tech Support:
email: memorymodule-help@idt.com
phone: 408-284-8208