



QUICKSWITCH® PRODUCTS HIGH-PERFORMANCE CMOS ANALOG FOUR-CHANNEL SPST SWITCH WITH INDIVIDUAL ENABLES

IDTQS4A101

FEATURES:

- Low ON resistance: $r_{DS(on)} = 5\Omega$
- Wide bandwidth: 1.4GHz (-3dB point)
- Crosstalk: 122dB at 50KHz, -80dB at 5MHz, -65dB at 30MHz
- Off-isolation: -100dB at 50KHz, -75dB at 5MHz, -45dB at 30MHz
- Single 5V supply
- Bidirectional signal flow
- TTL-compatible control inputs
- Ultra-low quiescent current: 3 μ A
- Switch turn on time of 6.5ns
- Available in QSOP package

APPLICATIONS:

- High-speed video signal switching/routing
- Audio signal switching/routing
- Data acquisition
- ATE systems
- Telecomm routing
- Token Ring transceivers
- High-speed networking

DESCRIPTION:

The QS4A101 is a high-performance CMOS analog four-channel SPST switch with individual enables. This device provides a set of four high-speed CMOS switches connecting inputs to outputs. The low ON resistance of the QS4A101 allows inputs to be connected to outputs with low insertion loss and high bandwidth.

The QS4A101, with 1.4GHz bandwidth, is ideal for high-performance video signal switching, audio signal switching, and telecomm routing applications. Low power dissipation makes this device ideal for battery operated and remote instrumentation applications.

The QS4A101 is offered in the QSOP package which has several advantages over conventional packages such as PDIP and SOIC, including:

- Reduced signal delays due to denser component packaging on circuit boards
- Reduced system noise due to less pin inductance

The QS4A101 is characterized for operation at -40°C to +85°C.

FUNCTIONAL BLOCK DIAGRAM

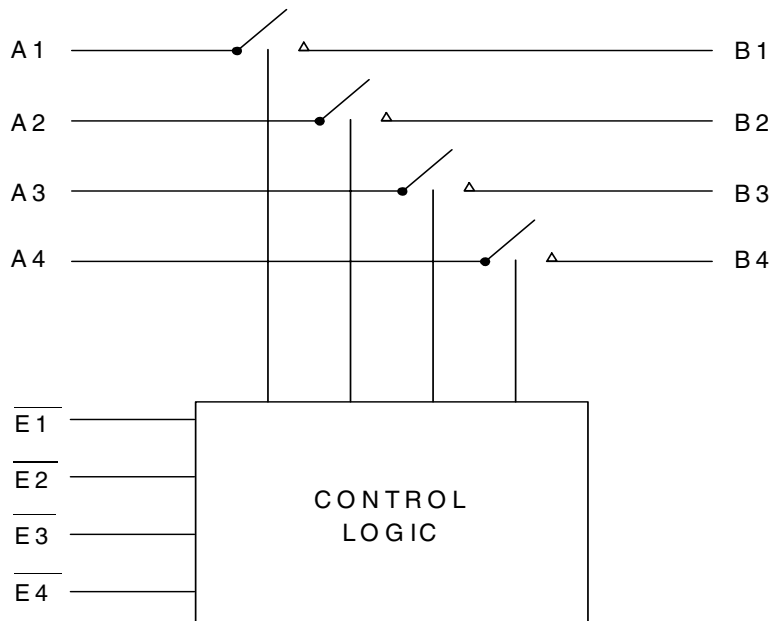

The IDT logo is a registered trademark of Integrated Device Technology, Inc.

INDUSTRIAL TEMPERATURE RANGE

FEBRUARY 2009

PIN CONFIGURATION

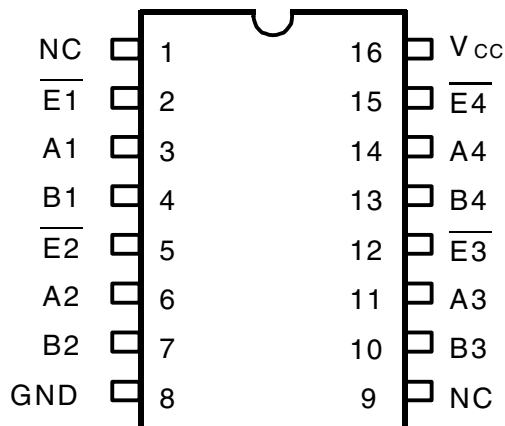

QSOP
TOP VIEW

ABSOLUTE MAXIMUM RATINGS(1)

Symbol	Description	Max	Unit
VTERM ⁽²⁾	Supply Voltage to Ground	-0.5 to +7	V
VTERM ⁽³⁾	DC Switch Voltage V _s	-0.5 to +7	V
—	Analog Input Voltage	-0.5 to +7	V
VTERM ⁽³⁾	DC Input Voltage V _{IN}	-0.5 to +7	V
V _{AC}	AC Input Voltage (pulse width ≤20ns)	-3	V
I _{OUT}	DC Output Current	120	mA
P _{MAX}	Maximum Power Dissipation	0.7	W
T _{STG}	Storage Temperature	-65 to +150	°C

NOTES:

- Stresses greater than those listed under ABSOLUTE MAXIMUM RATINGS may cause permanent damage to the device. This is a stress rating only and functional operation of the device at these or any other conditions above those indicated in the operational sections of this specification is not implied. Exposure to absolute maximum rating conditions for extended periods may affect reliability.
- V_{CC} terminals.
- All terminals except V_{CC}.

PIN DESCRIPTION

Pin Names	I/O	Description
A ₁ -A ₄	I/O	Port A
B ₁ -B ₄	I/O	Port B
\bar{E}_1 - \bar{E}_4	I	Port Switch Enable

FUNCTION TABLE(1)

\bar{E}	A	B	Function
L	H	H	Connect
L	L	L	Connect
H	X	X	Disconnect

NOTE:

- H = HIGH Voltage Level
L = LOW Voltage Level
X = Don't Care

POWER SUPPLY CHARACTERISTICS

Symbol	Parameter	Test Conditions	Max.	Unit
I _{CC}	Supply Current	V _{CC} = Max., V _{IN} = GND or V _{CC}	3	μA

DC ELECTRICAL CHARACTERISTICS OVER OPERATING RANGE

Following Conditions Apply Unless Otherwise Specified:

Industrial: $T_A = -40^{\circ}\text{C}$ to $+85^{\circ}\text{C}$, $V_{CC} = 5\text{V} \pm 5\%$

Symbol	Parameter	Test Conditions	Min.	Typ. ⁽¹⁾	Max.	Unit
Analog Switch						
V_{IN}	Analog Signal Range ⁽²⁾		-0.5	1	$V_{CC} - 1$	V
$r_{DS(ON)}$	Drain-source ON resistance ^(2,3)	$V_{CC} = \text{Min.}, V_{IN} = 0\text{V}, I_{ON} = 30\text{mA}$	—	5	7	Ω
		$V_{CC} = \text{Min.}, V_{IN} = 2.4\text{V}, I_{ON} = 15\text{mA}$	—	13	17	
$I_{C(OFF)}$	Channel Off Leakage Current	$A = V_{CC}$ or 0V , $B = 0\text{V}$ or V_{CC} , $\bar{E} = V_{CC}$	—	1	—	nA
$I_{C(ON)}$	Channel On Leakage Current	$A = B = 0\text{V}$ (each channel is turned on sequentially)	—	1	—	nA
Digital Control						
V_{IH}	Input HIGH Voltage	Guaranteed Logic HIGH for Control Pins	2	—	—	V
V_{IL}	Input LOW Voltage	Guaranteed Logic LOW for Control Pins	—	—	0.8	V
Dynamic Characteristics						
$t_{ON(\bar{E})}$	Enable Turn-On Time \bar{E} to A, B	$R_L = 1\text{K}\Omega, C_L = 100\text{pF}$ (See Switching Time)	0.5	—	6.5	ns
$t_{OFF(\bar{E})}$	Enable Turn-Off Time \bar{E} to A, B	$R_L = 1\text{K}\Omega, C_L = 100\text{pF}$ (See Switching Time)	0.5	—	6	ns
t_{PD}	Group Delay ^(2,4a)	$R_L = 1\text{K}\Omega, C_L = 100\text{pF}$	—	—	250	ps
f_{3dB}	-3dB Bandwidth	$V_{IN} = 0$ to 1V , 1V_{p-p} , $R_L = 75\Omega$	—	1.4	—	GHz
	Off-isolation	$V_{IN} = 0$ to 1V , 1V_{p-p} , $R_L = 75\Omega$, $f = 5.5\text{MHz}$	—	-80	—	dB
XTALK	Crosstalk	$V_{IN} = 0$ to 1V , 1V_{p-p} , $R_L = 75\Omega$, $f = 30\text{MHz}$	—	-75	—	dB
$C_{(OFF)}$	Switch Off Capacitance	$\bar{E} = V_{CC}, V_{IN} = V_{OUT} = 0\text{V}$	—	5	—	pF
$C_{(ON)}$	Switch On Capacitance	$\bar{E} = 0\text{V}, V_{IN} = V_{OUT} = 0\text{V}$	—	10	—	pF
QCI	Charge Injection		—	1.5	—	pC

NOTES:

- Typical values are at $V_{CC} = 5.0\text{V}$, $T_A = 25^{\circ}\text{C}$.
- Max value is guaranteed but not production tested.
- Measured by voltage drop between A and C pins at indicated current through the switch. ON resistance is determined by the lower of the voltages on the two (A, B) pins.
- The bus switch contributes no group delay other than the RC delay of the ON resistance of the switch and load capacitance. Group delay of the bus switch, when used in a system, is determined by the driving circuit on the driving side of the switch and its interaction with the load on the driven side.

TYPICAL CHARACTERISTICS

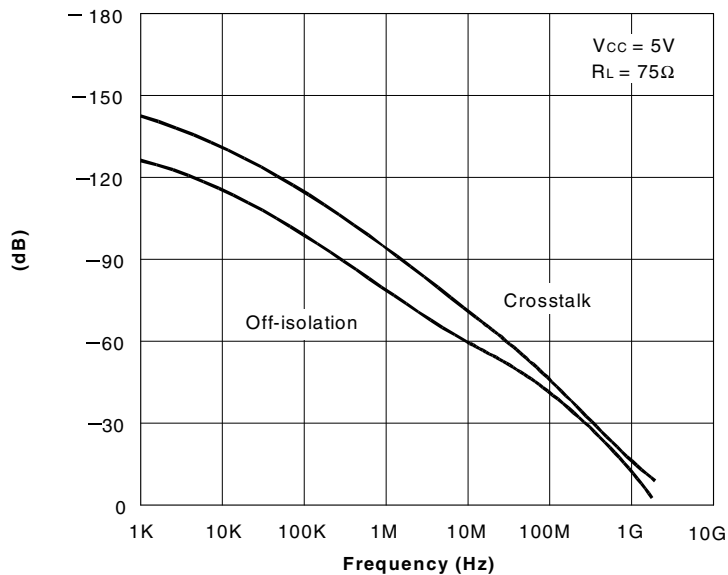

Off-isolation and Crosstalk vs. Frequency

NOTES:

1. Crosstalk = $20 \log |V_o/V_s|$
2. Off-isolation = $20 \log |V_o/V_s|$

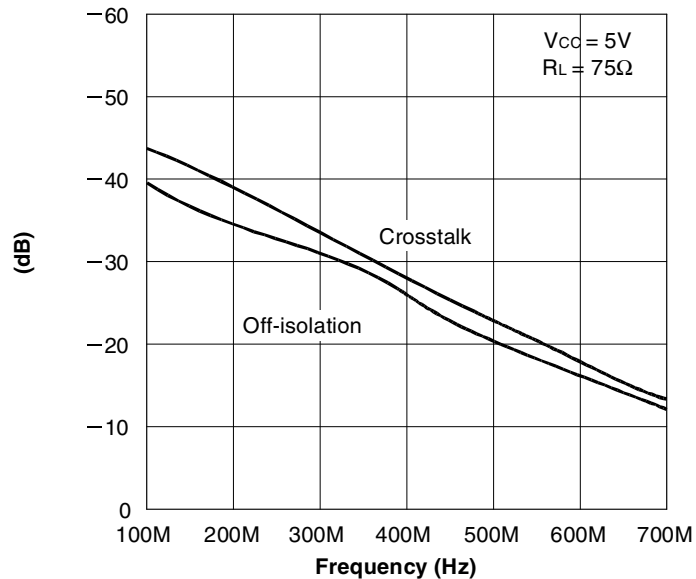

Off-isolation and Crosstalk vs. Frequency

NOTES:

1. Crosstalk = $20 \log |V_o/V_s|$
2. Off-isolation = $20 \log |V_o/V_s|$

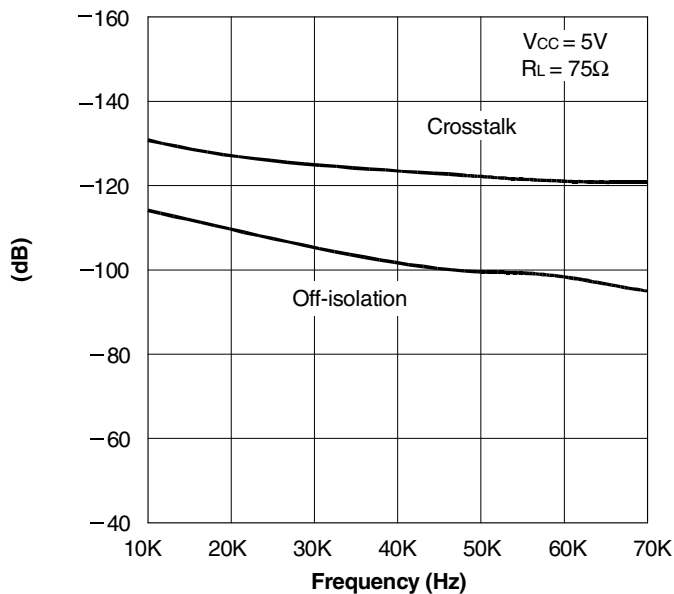

Off-isolation and Crosstalk vs. Frequency

NOTES:

1. Crosstalk = $20 \log |V_o/V_s|$
2. Off-isolation = $20 \log |V_o/V_s|$

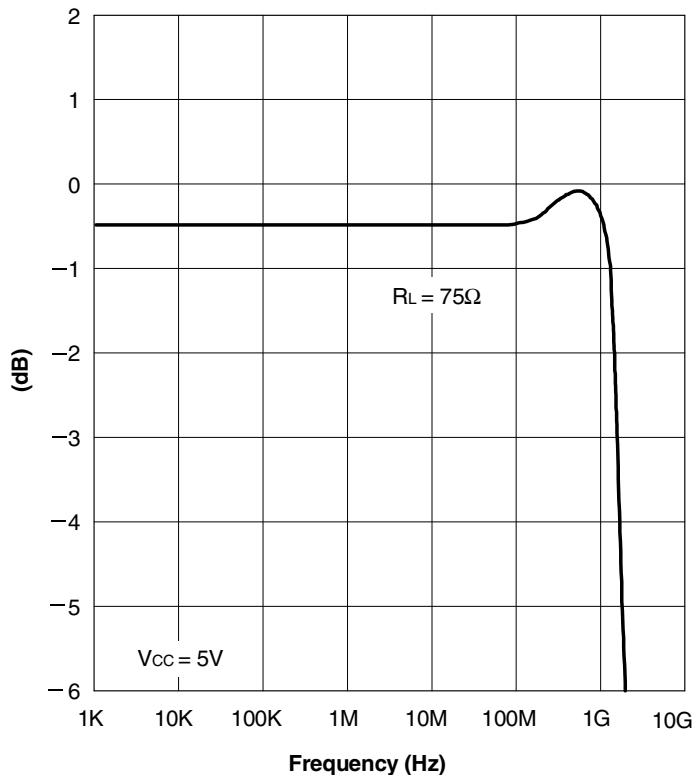

Insertion Loss vs. Frequency

NOTE:

1. Insertion Loss = $20 \log |V_o/V_s|$

TYPICAL CHARACTERISTICS (CONTINUED)

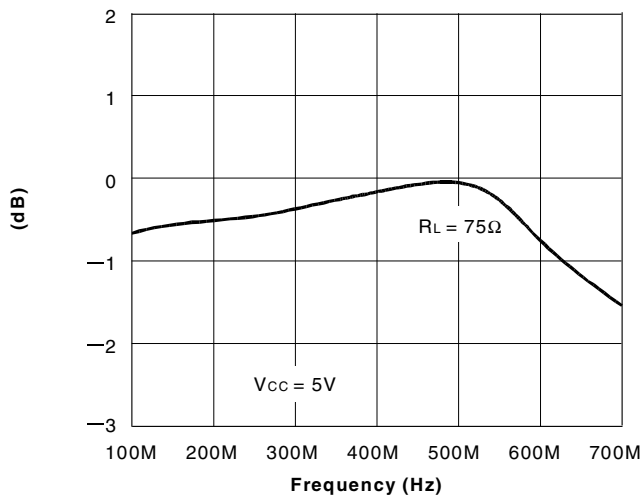

Insertion Loss vs. Frequency

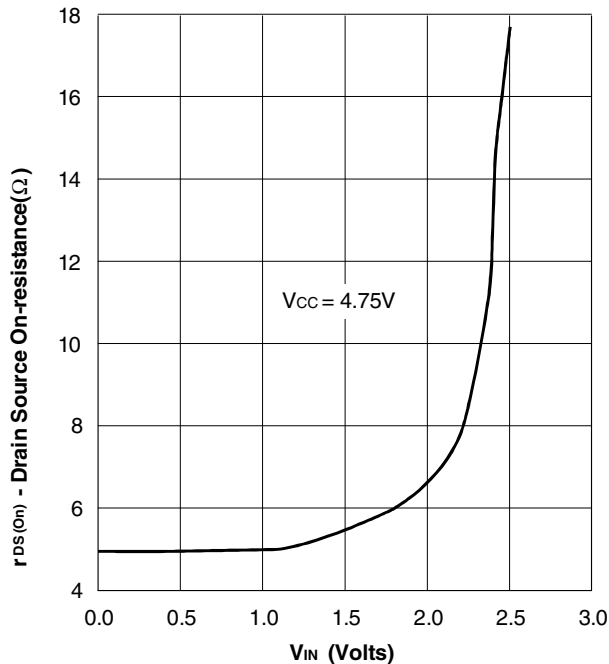

On-Resistance vs. VIN

RON LINK

NOTE:
1. Insertion Loss = $20 \log |V_o/V_i|$

TEST CIRCUITS

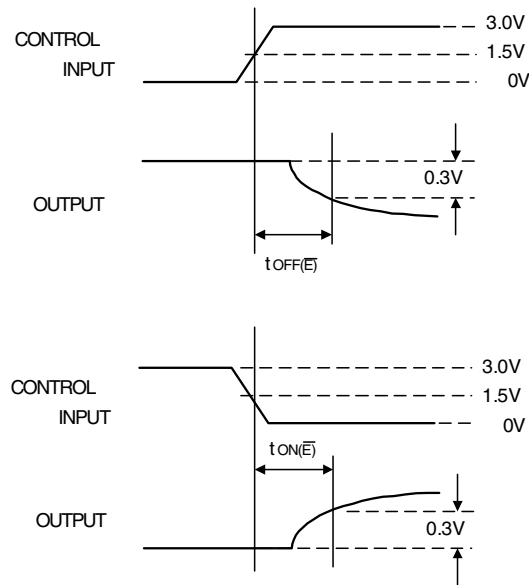
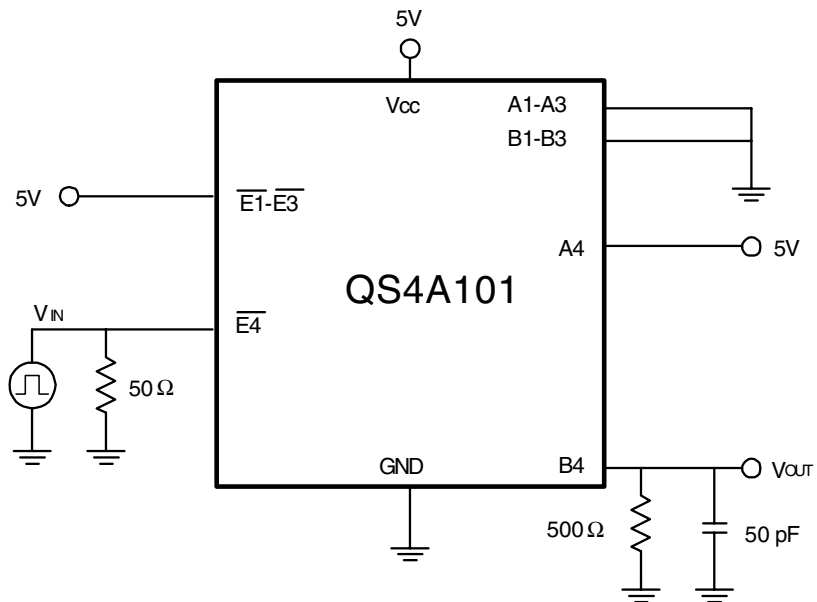

Switching Time

TEST CIRCUITS (CONTINUED)

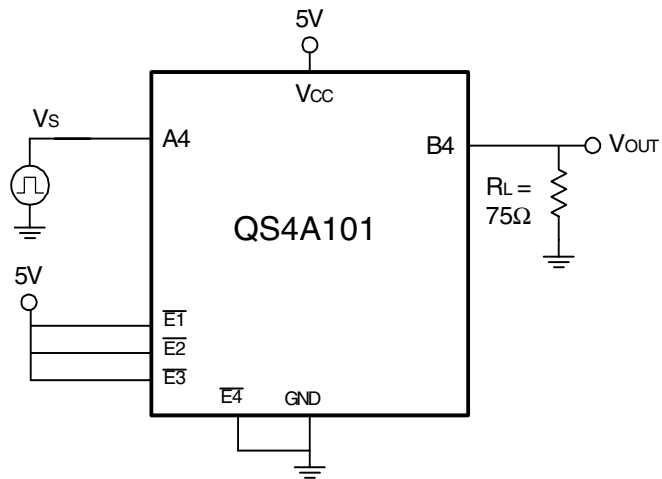

Insertion Loss

NOTES:

1. Insertion Loss = $20 \log |V_o/V_s|$
2. All unused pins are grounded.

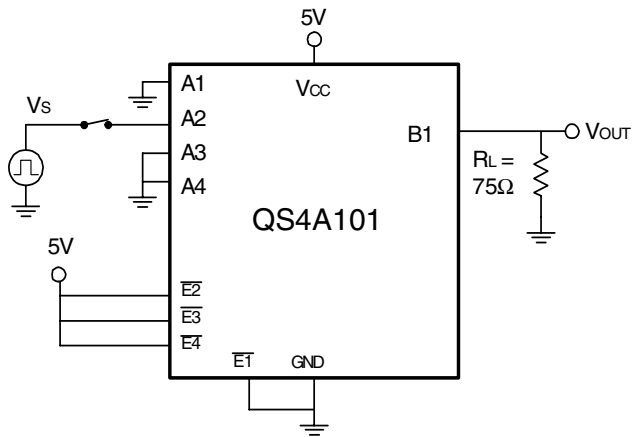

Crosstalk

NOTES:

1. Crosstalk = $20 \log |V_o/V_s|$
2. All unused pins are grounded.

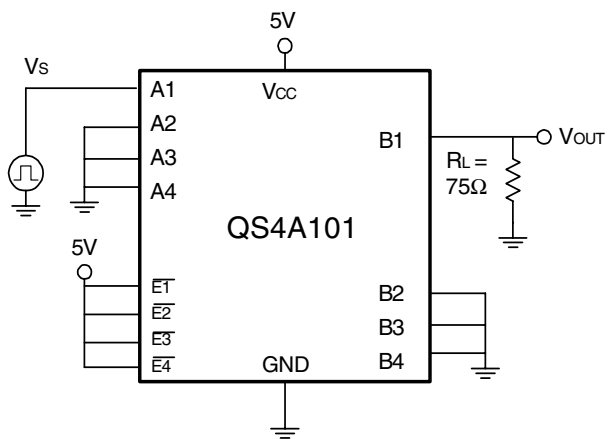

Off-Isolation

NOTE:

1. Off-isolation = $20 \log |V_o/V_s|$

ORDERING INFORMATION

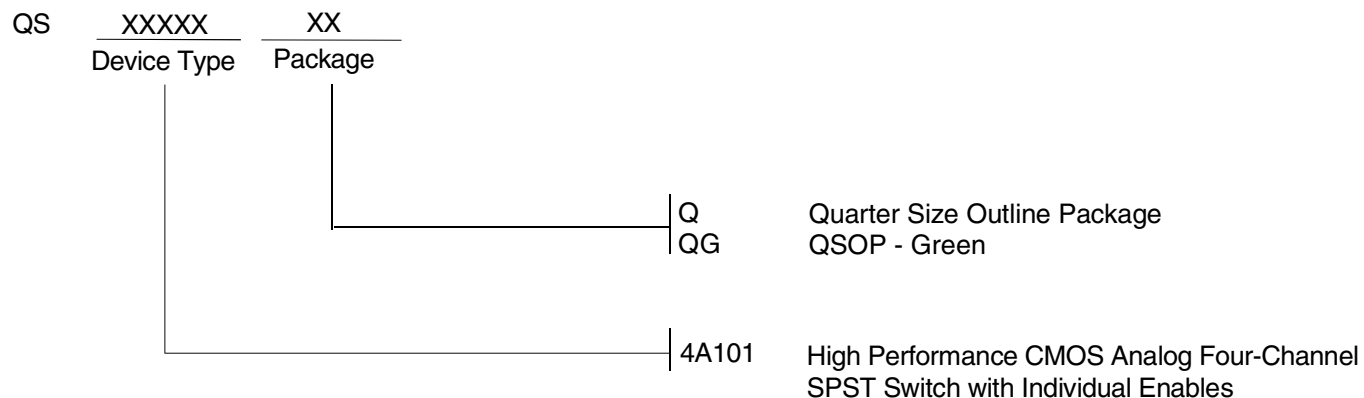

CORPORATE HEADQUARTERS
6024 Silver Creek Valley Road
San Jose, CA 95138

for SALES:
800-345-7015 or 408-284-8200
fax: 408-284-2775
www.idt.com

for Tech Support:
logichelp@idt.com