



# QUICKSWITCH® PRODUCTS

## 2.5V / 3.3V 16-BIT HIGH BANDWIDTH BUS SWITCH

### IDTQS32XVH245

#### FEATURES:

- N channel FET switches with no parasitic diode to Vcc
  - Isolation under power-off conditions
  - No DC path to Vcc or GND
  - 5V tolerant in OFF and ON state
- 5V tolerant I/Os
- Low RON - 4Ω typical
- Flat RON characteristics over operating range
- Rail-to-rail switching 0 - 5V
- Bidirectional dataflow with near-zero delay: no added ground bounce
- Excellent RON matching between channels
- VCC operation: 2.3V to 3.6V
- High bandwidth - up to 500MHz
- LVTTTL-compatible control Inputs
- Undershoot Clamp Diodes on all switch and control Inputs
- Low I/O capacitance, 4pF typical
- Available in 40-pin QVSOP package

#### APPLICATIONS:

- Hot-swapping
- 10/100 Base-T, Ethernet LAN switch
- Low distortion analog switch
- Replaces mechanical relay
- ATM 25/155 switching

#### DESCRIPTION:

The QS32XVH245 HotSwitch is a high bandwidth, 16-bit bus switch. The QS32XVH245 has very low ON resistance, resulting in under 250ps propagation delay through the switch. The switches can be turned ON under the control of the LVTTTL-compatible Output Enable ( $\overline{OE}x$ ) signal for bidirectional data flow with no added delay or ground bounce. In the ON state, the switches can pass signals up to 5V. In the OFF state, the switches offer very high impedance at the terminals.

The combination of near-zero propagation delay, high OFF impedance, and over-voltage tolerance makes the QS32XVH245 ideal for high performance communications applications.

The QS32XVH245 is characterized for operation from -40°C to +85°C.5°C.

#### FUNCTIONAL BLOCK DIAGRAM

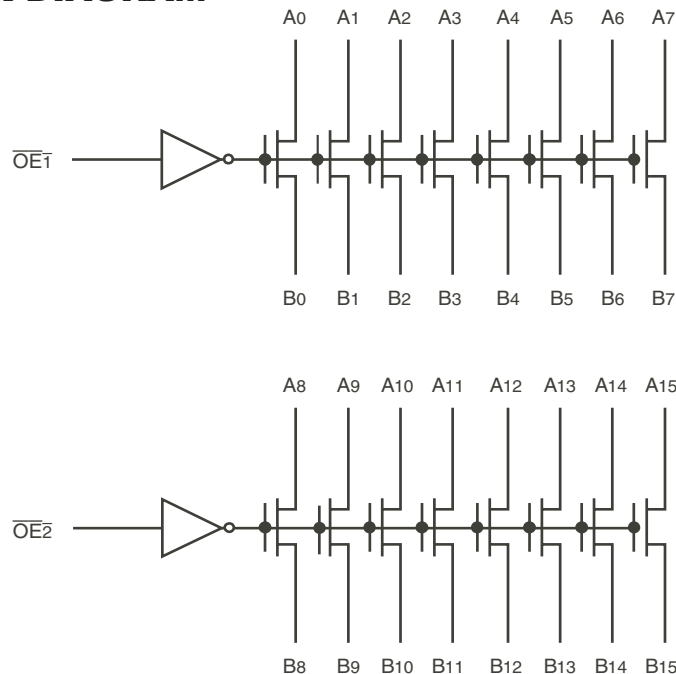

The IDT logo is a registered trademark of Integrated Device Technology, Inc.

**INDUSTRIAL TEMPERATURE RANGE**

**JUNE 2011**

## PIN CONFIGURATION

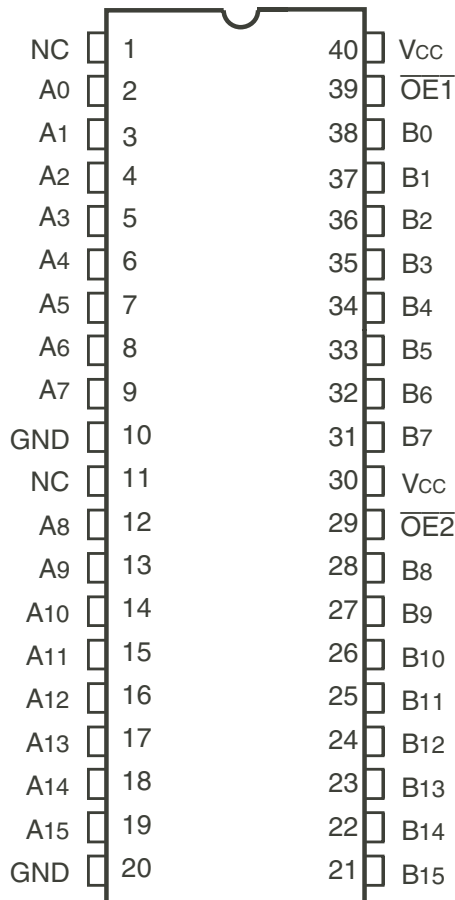

QVSOP  
TOP VIEW

## ABSOLUTE MAXIMUM RATINGS<sup>(1)</sup>

Symbol	Description	Max	Unit
V <sub>TERM</sub> <sup>(2)</sup>	Supply Voltage to Ground	-0.5 to +4.6	V
V <sub>TERM</sub> <sup>(3)</sup>	DC Switch Voltage V <sub>s</sub>	-0.5 to +5.5	V
V <sub>TERM</sub> <sup>(3)</sup>	DC Input Voltage V <sub>IN</sub>	-0.5 to +5.5	V
V <sub>AC</sub>	AC Input Voltage (pulse width ≤20ns)	-3	V
I <sub>OUT</sub>	DC Output Current (max. sink current/pin)	120	mA
T <sub>STG</sub>	Storage Temperature	-65 to +150	°C

### NOTES:

- Stresses greater than those listed under ABSOLUTE MAXIMUM RATINGS may cause permanent damage to the device. This is a stress rating only and functional operation of the device at these or any other conditions above those indicated in the operational sections of this specification is not implied. Exposure to absolute maximum rating conditions for extended periods may affect reliability.
- V<sub>CC</sub> terminals.
- All terminals except V<sub>CC</sub>.

## CAPACITANCE (T<sub>A</sub> = +25°C, F = 1MHz, V<sub>IN</sub> = 0V, V<sub>OUT</sub> = 0V)

Symbol	Parameter <sup>(1)</sup>	Typ.	Max.	Unit
C <sub>IN</sub>	Control Inputs	3	5	pF
C <sub>I/O</sub>	Quickswitch Channels (Switch OFF)	4	6	pF
C <sub>I/O</sub>	Quickswitch Channels (Switch ON)	8	12	pF

### NOTE:

- This parameter is guaranteed but not production tested.

## PIN DESCRIPTION

Pin Names	I/O	Description
$\overline{OE}x$	I	Output Enable
A <sub>x</sub>	I/O	Bus A
B <sub>x</sub>	I/O	Bus B

## FUNCTION TABLE<sup>(1)</sup>

$\overline{OE}x$	Function
H	Disconnect
L	Connect (A <sub>x</sub> = B <sub>x</sub> )

### NOTE:

- H = HIGH Voltage Level  
L = LOW Voltage Level

## DC ELECTRICAL CHARACTERISTICS OVER OPERATING RANGE

Following Conditions Apply Unless Otherwise Specified:

Industrial:  $T_A = -40^{\circ}\text{C}$  to  $+85^{\circ}\text{C}$ ,  $V_{CC} = 3.3\text{V} \pm 0.3\text{V}$

Symbol	Parameter	Test Conditions			Min.	Typ. <sup>(1)</sup>	Max.	Unit
V <sub>IH</sub>	Input HIGH Voltage	Guaranteed Logic HIGH for Control Inputs	V <sub>CC</sub> = 2.3V to 2.7V	1.7	—	—	V	
			V <sub>CC</sub> = 2.7V to 3.6V	2	—	—		
V <sub>IL</sub>	Input LOW Voltage	Guaranteed Logic LOW for Control Inputs	V <sub>CC</sub> = 2.3V to 2.7V	—	—	0.7	V	
			V <sub>CC</sub> = 2.7V to 3.6V	—	—	0.8		
I <sub>IN</sub>	Input Leakage Current (Control Inputs)	0V ≤ V <sub>IN</sub> ≤ V <sub>CC</sub>			—	—	±1	μA
I <sub>OZ</sub>	Off-State Current (Hi-Z)	0V ≤ V <sub>OUT</sub> ≤ 5V, Switches OFF			—	—	±1	μA
I <sub>OFF</sub>	Data Input/Output Power Off Leakage	V <sub>IN</sub> or V <sub>OUT</sub> 0V to 5V, V <sub>CC</sub> = 0V			—	—	±1	μA
R <sub>ON</sub>	Switch ON Resistance	V <sub>CC</sub> = 2.3V Typical at V <sub>CC</sub> = 2.5V	V <sub>IN</sub> = 0V	I <sub>ON</sub> = 30mA	—	6	8	Ω
			V <sub>IN</sub> = 1.7V	I <sub>ON</sub> = 15mA	—	7	9	
		V <sub>CC</sub> = 3V	V <sub>IN</sub> = 0V	I <sub>ON</sub> = 30mA	—	4	6	
			V <sub>IN</sub> = 2.4V	I <sub>ON</sub> = 15mA	—	5	8	

**NOTE:**

1. Typical values are at V<sub>CC</sub> = 3.3V and T<sub>A</sub> = 25°C.

### TYPICAL ON RESISTANCE vs V<sub>IN</sub> AT V<sub>CC</sub> = 3.3V

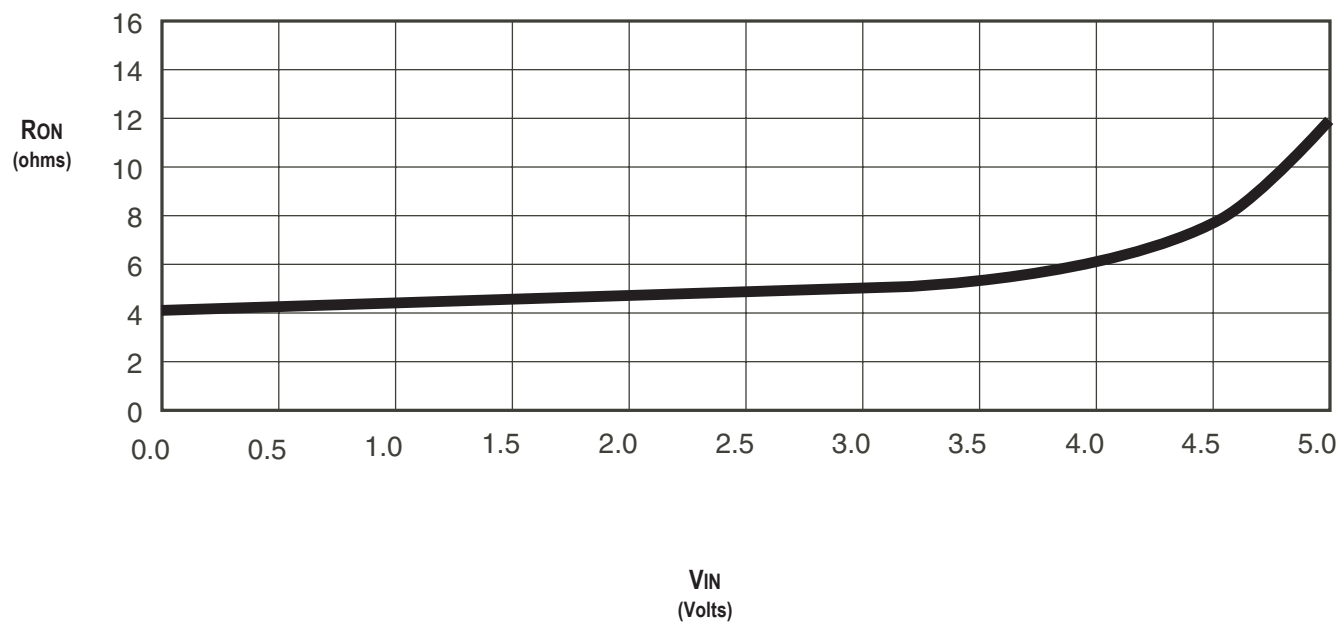

## POWER SUPPLY CHARACTERISTICS

Symbol	Parameter	Test Conditions <sup>(1)</sup>	Min.	Typ.	Max.	Unit
I <sub>CCQ</sub>	Quiescent Power Supply Current	V <sub>CC</sub> = Max., V <sub>IN</sub> = GND or V <sub>CC</sub> , f = 0	—	4	8	mA
ΔI <sub>CC</sub>	Power Supply Current <sup>(2,3)</sup> per Input HIGH	V <sub>CC</sub> = Max., V <sub>IN</sub> = 3V, f = 0 per Control Input	—	—	30	μA
I <sub>CCD</sub>	Dynamic Power Supply Current per Output Enable Control Input <sup>(4)</sup>	V <sub>CC</sub> = 3.3V, A and B Pins Open, Control Inputs Toggling @ 50% Duty Cycle	See Typical I <sub>CCD</sub> vs Enable Frequency graph below			

**NOTES:**

1. For conditions shown as Min. or Max., use the appropriate values specified under DC Electrical Characteristics.
2. Per input driven at the specified level. A and B pins do not contribute to ΔI<sub>CC</sub>.
3. This parameter is guaranteed but not tested.
4. This parameter represents the current required to switch internal capacitance at the specified frequency. The A and B inputs do not contribute to the Dynamic Power Supply Current. This parameter is guaranteed but not production tested.

### TYPICAL I<sub>CCD</sub> vs ENABLE FREQUENCY CURVE AT V<sub>CC</sub> = 3.3V

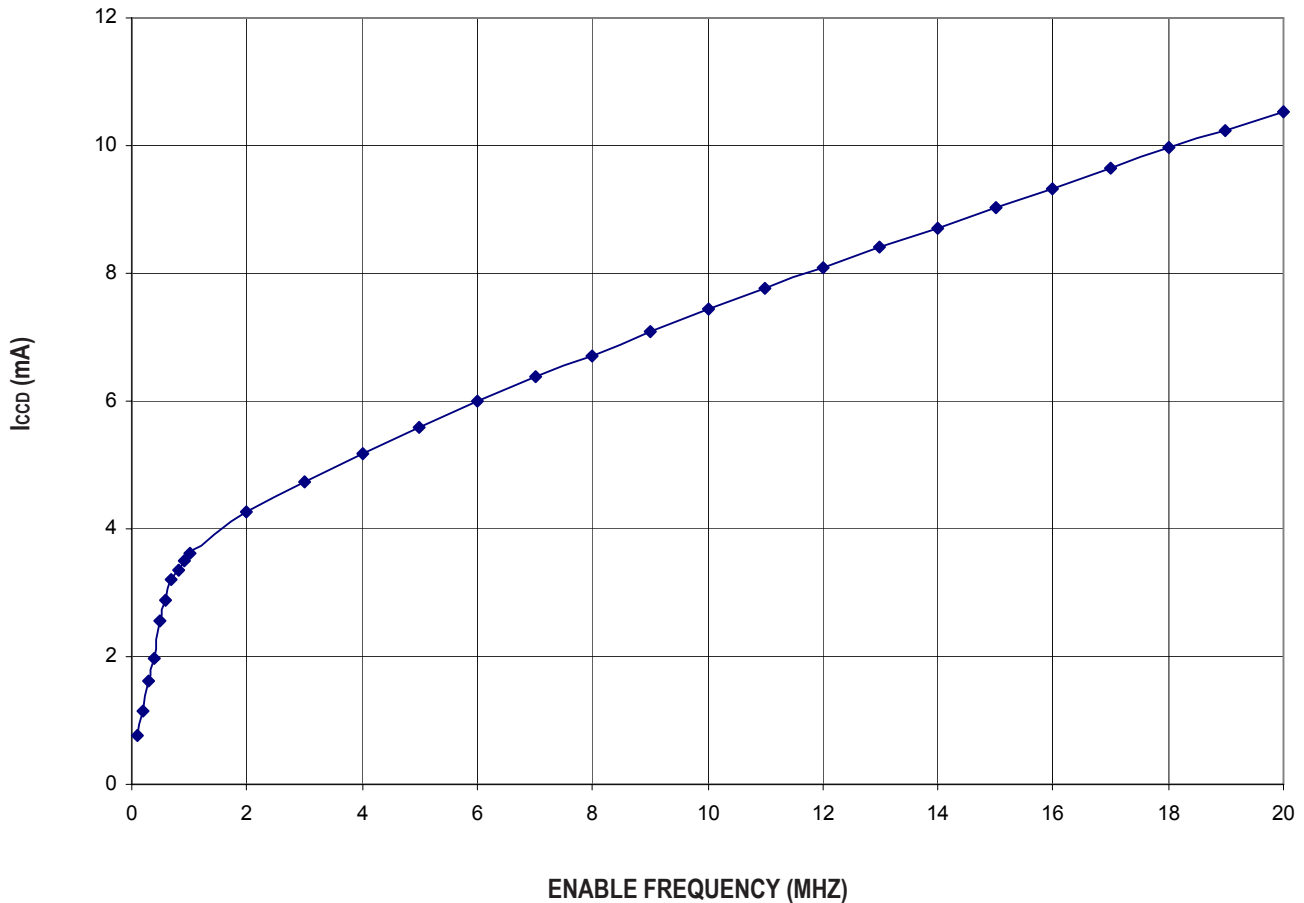

## SWITCHING CHARACTERISTICS OVER OPERATING RANGE

T<sub>A</sub> = -40°C to +85°C

Symbol	Parameter	V <sub>CC</sub> = 2.5 ± 0.2V <sup>(1)</sup>		V <sub>CC</sub> = 3.3 ± 0.3V <sup>(1)</sup>		Unit
		Min. <sup>(4)</sup>	Max.	Min. <sup>(4)</sup>	Max.	
t <sub>PLH</sub>	Data Propagation Delay <sup>(2,3)</sup>	—	0.2	—	0.2	ns
t <sub>PHL</sub>	Ax to/from Bx					
t <sub>PZL</sub>	Switch Turn-On Delay	1.5	8	1.5	7	ns
t <sub>PZH</sub>	OEx to Ax/Bx					
t <sub>PLZ</sub>	Switch Turn-Off Delay	1.5	7	1.5	6.5	ns
t <sub>PHZ</sub>	OEx to Ax/Bx					
f <sub>OEx</sub>	Operating Frequency - Enable <sup>(2,5)</sup>	—	10	—	20	MHz

### NOTES:

1. See Test Conditions under TEST CIRCUITS AND WAVEFORMS.
2. This parameter is guaranteed but not production tested.
3. The bus switch contributes no propagation delay other than the RC delay of the ON resistance of the switch and the load capacitance. The time constant for the switch alone is of the order of 0.2ns at C<sub>L</sub> = 50pF. Since this time constant is much smaller than the rise and fall times of typical driving signals, it adds very little propagation delay to the system. Propagation delay of the bus switch, when used in a system, is determined by the driving circuit on the driving side of the switch and its interaction with the load on the driven side.
4. Minimums are guaranteed but not production tested.
5. Maximum toggle frequency for OEx control input (pass voltage > V<sub>CC</sub>, V<sub>IN</sub> = 5V, R<sub>LOAD</sub> ≥ 1MΩ, no C<sub>LOAD</sub>).

## SOME APPLICATIONS FOR HOTSWITCH PRODUCTS

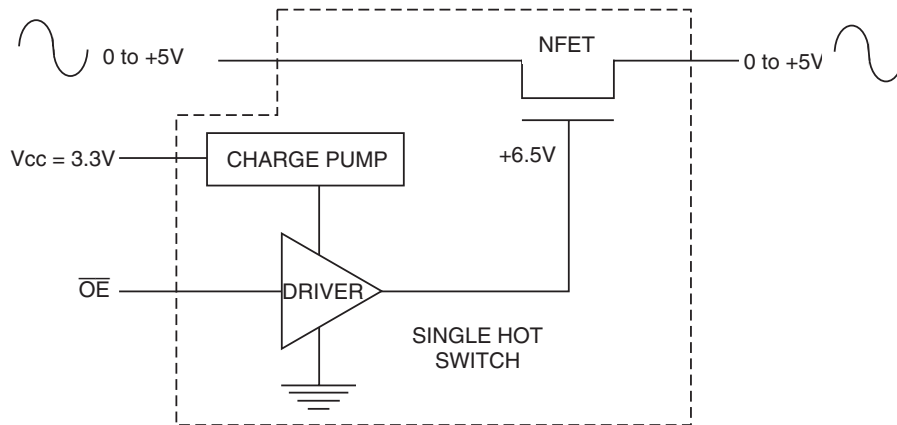

*Rail-to-Rail Switching*

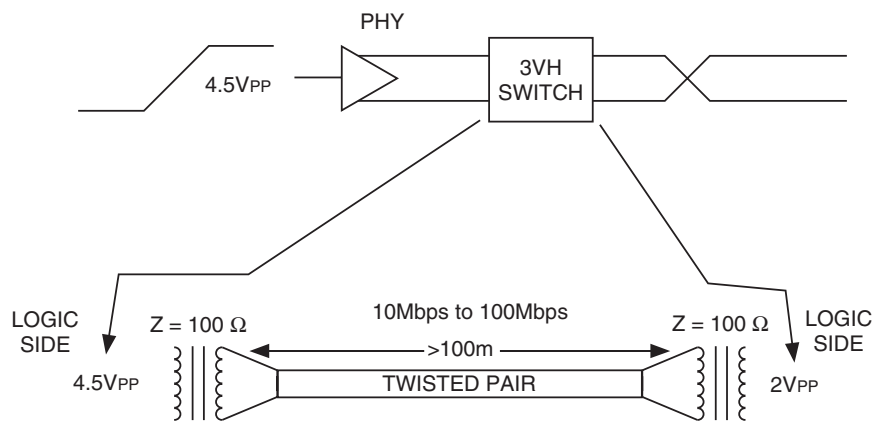

*Fast Ethernet Data Switching (LAN Switch)*

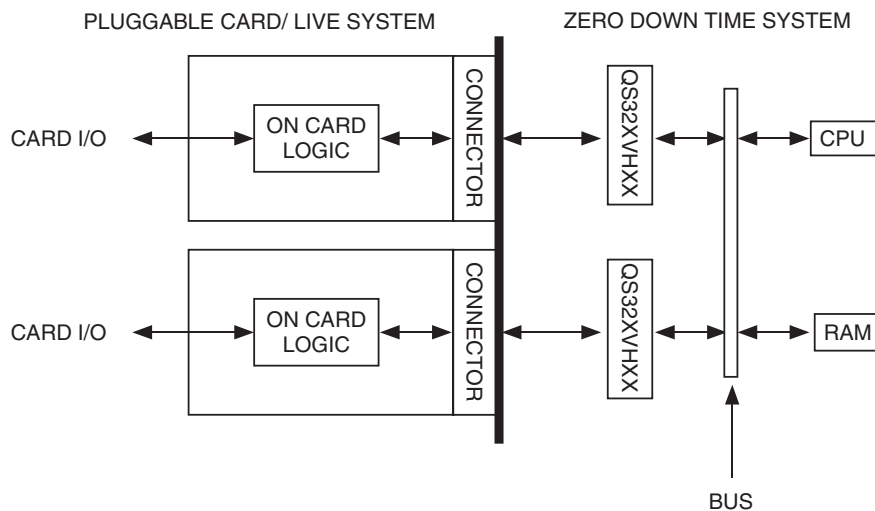

*Hot-Swapping*

## TEST CIRCUITS AND WAVEFORMS

### TEST CONDITIONS

Symbol	Vcc <sup>(1)</sup> = 3.3V ± 0.3V	Vcc <sup>(2)</sup> = 2.5V ± 0.2V	Unit
V <sub>LOAD</sub>	6	2 x V <sub>cc</sub>	V
V <sub>IH</sub>	3	V <sub>cc</sub>	V
V <sub>T</sub>	1.5	V <sub>cc</sub> /2	V
V <sub>LZ</sub>	300	150	mV
V <sub>HZ</sub>	300	150	mV
C <sub>L</sub>	50	30	pF

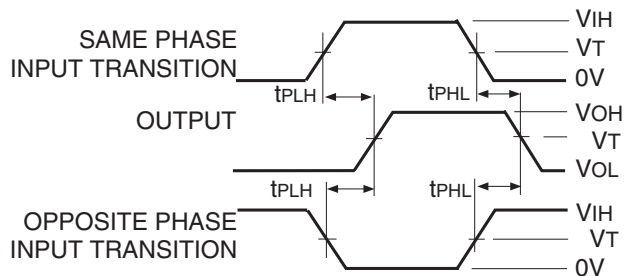

Propagation Delay

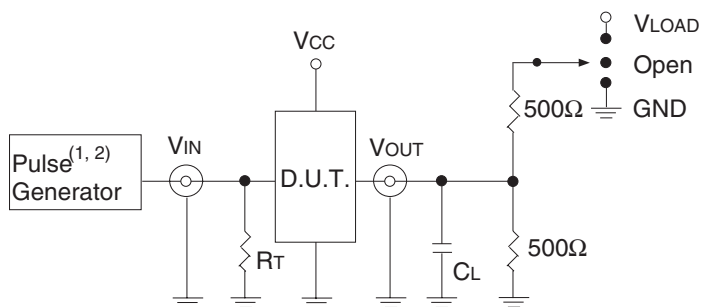

Test Circuits for All Outputs

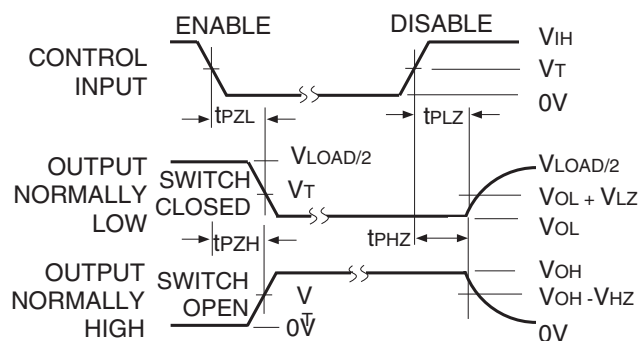

**NOTE:**

1. Diagram shown for input Control Enable-LOW and input Control Disable-HIGH.

### Enable and Disable Times

**DEFINITIONS:**

C<sub>L</sub> = Load capacitance: includes jig and probe capacitance.

R<sub>T</sub> = Termination resistance: should be equal to Z<sub>OUT</sub> of the Pulse Generator.

**NOTES:**

1. Pulse Generator for All Pulses: Rate ≤ 10MHz; t<sub>r</sub> ≤ 2.5ns; t<sub>f</sub> ≤ 2.5ns.

2. Pulse Generator for All Pulses: Rate ≤ 10MHz; t<sub>r</sub> ≤ 2ns; t<sub>f</sub> ≤ 2ns.

## SWITCH POSITION

Test	Switch
t <sub>PLZ</sub> /t <sub>PZL</sub>	V <sub>LOAD</sub>
t <sub>PHZ</sub> /t <sub>PZH</sub>	GND
t <sub>PD</sub>	Open

**ORDERING INFORMATION**

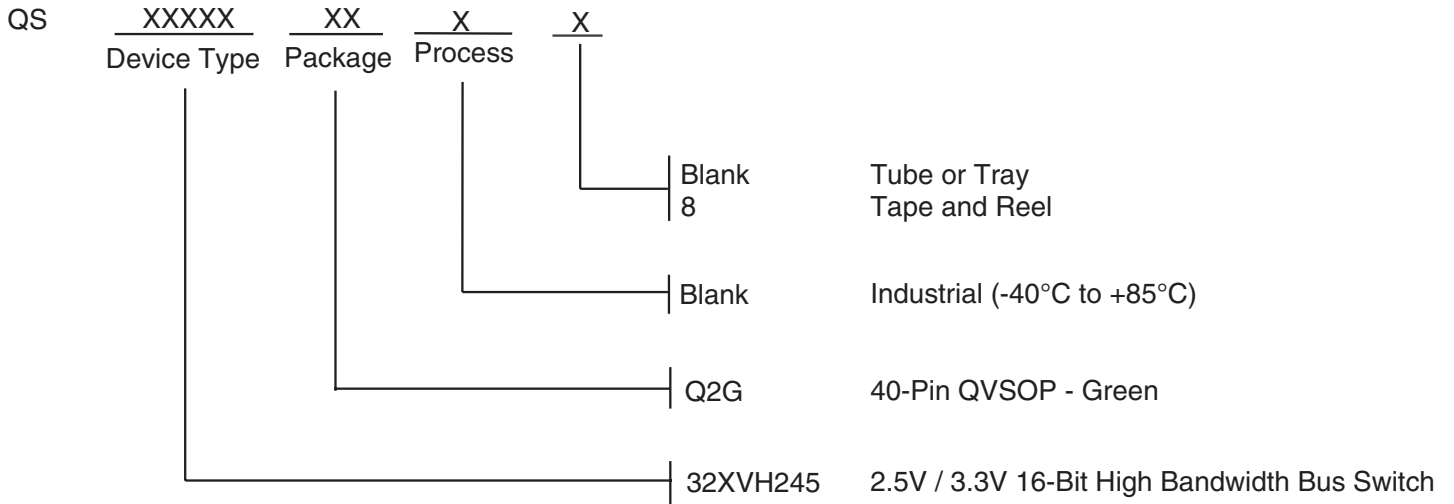

**Datasheet Document History**

09/01/08	Pg. 4, 8	Revise ICCQ Typ. and Max. Remove non green package version and updated the ordering information by removing the "IDT" notation.
06/14/11	Pg. 8	Updated ordering information to include tube or tray and tape & reel.



**CORPORATE HEADQUARTERS**  
 6024 Silver Creek Valley Road  
 San Jose, CA 95138

**for SALES:**  
 800-345-7015 or 408-284-8200  
 fax: 408-284-2775  
 www.idt.com

**for Tech Support:**  
 logichelp@idt.com