

AvnetCore: Datasheet

Version 1.0, July 2006

POS-PHY Level 3 Link

Intended Use:

- Packet Processors
- POS switches
- PHY processors
- UNI/MAC
- POS bridges

Features:

- Function compatible with ATM Forum af-phy-0143.000
- Asynchronous/synchronous FIFO using RAM
- Up to 256 PHY ports supported
- Special single PHY mode for smaller footprint
- 8-bit & 32-bit interfaces supported
- Nonstandard 16-bit interface also supported
- Direct & polled status
- Programmable HIGH and LOW FIFO watermarks
- Simple system-side FIFO interface
- Flow control and polling integrated

Targeted Devices:

- Accelerator[®] Family

Core Deliverables:

- Netlist Version
 - > Netlist compatible with the Actel Designer place and route tool
 - > Compiled RTL simulation model, compliant with the Actel Libero[®] environment
- RTL Version
 - > VHDL Source Code
- All
 - > User Guide
 - > Test Bench

Synthesis and Simulation Support:

- Synthesis: Synplicity[®]
- Simulation: ModelSim[®]
- Other tools supported upon request

Verification:

- Test Bench
- Test Vectors

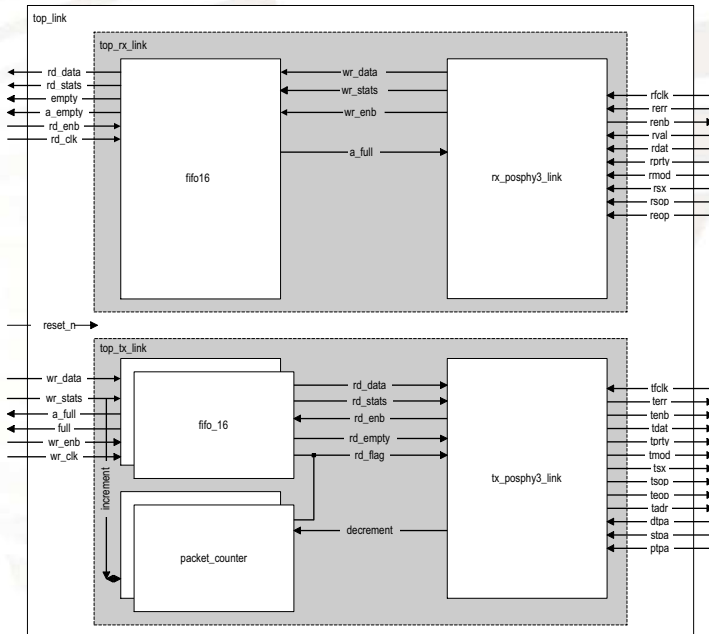

Block Diagram

POS-PHY Level 3 was developed to cover all application bit rates up to and including 2.4 Gbit/s. It defines the requirements for interoperable single-PHY (one PHY layer device connected to one Link Layer device) and multi-PHY (multiple PHY layer devices connected to one Link Layer device) applications. It stresses simplicity of operation to allow forward migration to more elaborate PHY and Link Layer devices. This core conforms to the ATM Forum af-phy-0143.000. In general, standards do not define the internal user interface, only the external interfaces and protocols. Therefore, Avnet Memec has created a simple FIFO interface to this core for easy user connectivity. Please consult the appropriate standards document for all external signaling.

Functional Description

This core conforms to the appropriate standard(s). In general, standards do not define the internal user interface, only the external interfaces and protocols. Therefore, Avnet Memec has created a simple FIFO interface to this core for easy user connectivity. This document describes this Avnet Memec created interface. Please consult the appropriate standards document for all external signaling.

TOP_LINK

This is the top level of the core. Its only purpose is to serve as a container to instantiate the transmit (TX) & receive (RX) modules. TOP_LINK is also where the generics are located that configure the core. These parameters are then passed down to the TX & RX modules. This is an optional module as the TOP_TX_LINK, and the TOP_RX_LINK modules may be instantiated separately (even in different FPGAs).

TOP_TX_LINK & TOP_RX_LINK

These modules comprise the transmit & receive portions of the interface. They were developed so that they may be instantiated either separately in different FPGAs or together in one FPGA. They use common sub-modules FIFO_16 for simplicity and reliability.

TX_POSPHY3_LINK

The TX LINK is responsible for polling the PHY in order to send packets.

RX_POSPHY3_LINK

The RX LINK is responsible for receiving packets from the PHY.

PACKET_COUNTER

The packet counter module (one per PHY port) is responsible for generating the packet available flags for the core. Every time an EOP (End of Packet) is written the packet count goes up and when a EOP is read the packet count goes down. This allows the core to send data when there is an EOP in the FIFO even if the FIFO low watermark hasn't been reached.

FIFO_16

The FIFO module contains one FIFO per PHY polled (i.e. this module is instantiated N times, where N = number of PHY ports). The FIFOs are created by utilizing the available embedded memory resources in the FPGA. The FIFO may be operated in synchronous (same clock for read & write) and asynchronous (different clocks for read & write) systems.

The user provides wr_data and wr_stats to the FIFO interface. This is concatenated into a single bus and written into the FIFO. For example, if the data_size is 8, then the wr_data would be 8 bits wide and the wr_stats would be 8 bits wide. These two buses are concatenated together and written into the FIFO, which is 16 bits wide. This way there doesn't have to be a single FIFO for the stats and a single FIFO for the data, which would nearly double the size of the core. In the opposite direction the reverse takes place.

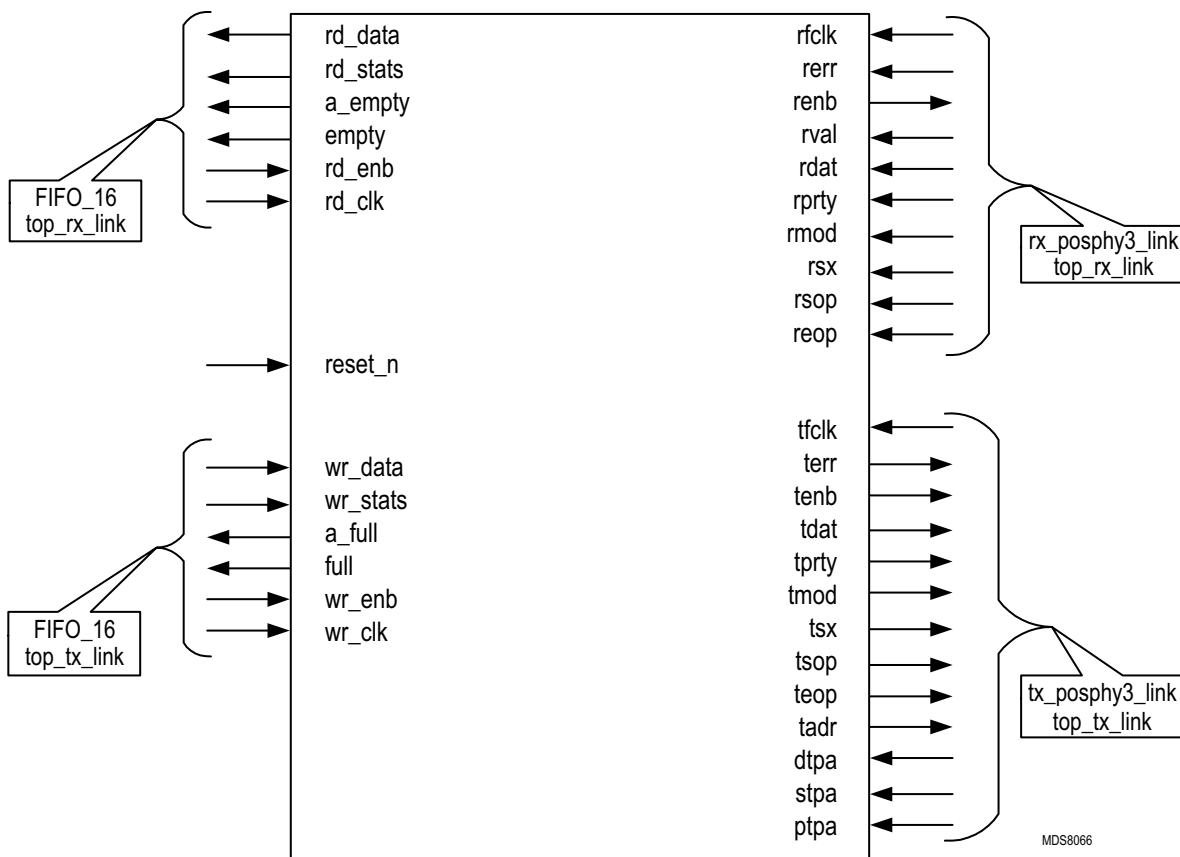

Figure 1: Logic Symbol

Device Requirements

MC-ACT-PL3LINK (POS-PHY Level 3 LINK Interface)					
Device	Speed RFCLK / TFCLK	C cells	R cells	Tiles	RAM's
A3PE600	103 / 97 MHz	-	-	1204 (9%)	9
APA150	99 / 84 MHz	-	-	1372 (22%)	15
AX250	155 / 119 MHz	453 (16%)	554 (39%)	-	9

Table 1: Device Utilization and Performance*

*Note: These numbers obtained with 4 channels and 16-bit data size.

Verification and Compliance

The testbench is self-checking, which means that if there is an error detected in the start word, end word, or payload the testbench will assert one or both of two error signals. The test checks for errors at two stages in the testbench: when the cells (packets) are looped back through the PHY device (SIG_LOOP_ERROR_OUT), and upon reading out of the link device (SIG_ERROR_OUT). This core has also been used successfully in customer designs.

Signal Descriptions

The following signal descriptions define the IO signals.

Signal	Width	Direction	Description
RD_DATA	DATA_SIZE	Output	Read data bus for the FIFOs.
RD_STATS	8	Output	Statistics for the link. Includes SOP, EOP, ERR, MOD, & PARITY.
A_EMPTY	1	Output	Indicates when FIFO is almost empty.
EMPTY	1	Output	Indicates when FIFO is empty.
RD_ENB	1	Input	Read enable signal for the FIFO.
RD_CLK	1	Input	Read clock for the FIFO.
RESET_N	1	Input	Reset signal from user logic.
WR_DATA	DATA_SIZE * NUM_PHYS	Input	Write data bus for FIFO.
WR_STATS	8	Input	Statistics for the link. Includes SOP, EOP, ERR, MOD, & PARITY.
A_FULL	NUM_PHYS	Output	Almost full for FIFOs indicates that the FIFO does not have enough room for an additional cell.
FULL	NUM_PHYS	Output	Indicates that the FIFO is full.
WR_ENB	NUM_PHYS	Input	Write enable signal for FIFO.
WR_CLK	1	Input	System clock for all registers in this block.
RFCLK	1	Input	104 MHz Clock for all registers in this block.
RERR	1	Input	POS-PHY Error signal used to flag an errored packet.
RENB	1	Output	POS-PHY Enable signal used for throttle control.
RVAL	1	Input	POS-PHY Valid signal used to indicate valid data on RDAT
RDAT	8, 16, 32	Input	POS-PHY Data Bus. 8-bit or 32-bit selectable.
RPRTY	1	Input	POS-PHY Parity used for odd parity on rdat.
RMOD	2	Input	POS-PHY signal used to indicate which bytes are valid in the last word of the packet.
RSX	1	Input	POS-PHY Select signal used to indicate the address on the rdat lines for selection.
RSOP	1	Input	POS-PHY Start of Packet signal used to flag the first byte/word in the packet.
REOP	1	Input	POS-PHY End of Packet signal used to flag the last byte/word in the packet.
TFCLK	1	Input	104 MHz Clock for all registers in this block.
TERR	1	Output	POS-PHY Error signal used to flag an errored packet.
TENB	1	Output	POS-PHY Enable signal used for throttle control.
TDAT	8, 16, 32	Output	POS-PHY Data Bus. 8-bit or 32-bit selectable.
TPRTY	1	Output	POS-PHY Parity used for odd parity on TDAT.
TMOD	2	Output	POS-PHY signal used to indicate which bytes are valid in the last word of the packet.
TSX	1	Output	POS-PHY Select signal used to indicate the address on the TDAT lines for selection.
TSOP	1	Output	POS-PHY Start of Packet signal used to flag the first byte/word in the packet.
TEOP	1	Output	POS-PHY End of Packet signal used to flag the last byte/word in the packet.
TADR	5	Output	POS-PHY Address Bus used for polling.
DTPA	4	Input	POS-PHY Packet Available signal used to indicate that the PHY has room for a cell when direct.
STPA	1	Input	POS-PHY Packet Available signal used to indicate that the selected PHY has room for a cell.
PTPA	1	Input	POS-PHY Packet Available signal used to indicate that the PHY has room for a cell when polled.

Table 2: Core I/O Signals

Timing

Since the ATM Forum specification fully defines the line side of the POS-PHY Level 3 interface, timing for that is not replicated here. Instead, only user (FIFO) interface timing information is presented here. The figure below shows the functional timing for FIFO reads and writes.

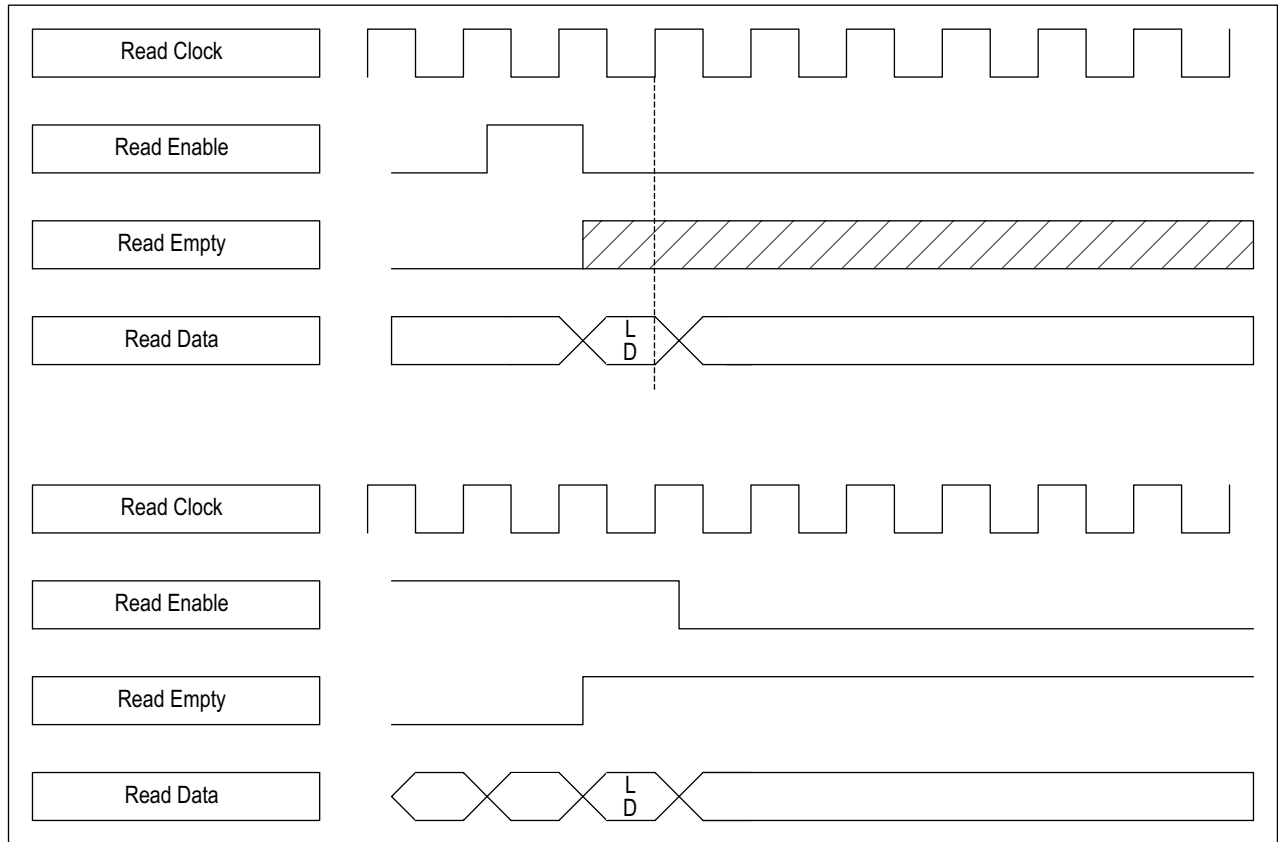

Figure 3: FIFO Timing

The top example shows where the last valid data word (LD) is clocked out relative to the deassertion of read enable. The bottom example shows read enable responding to the assertion of read empty.

Recommended Design Experience

For the source version, users should be familiar with HDL entry and Actel design flows. Users should be familiar with Actel Libero v2.2 Integrated Design Environment (IDE) and preferably with Synplify and ModelSim.

Ordering Information

The CORE is provided under license from Avnet Memec for use in Actel programmable logic devices. Please contact Avnet Memec for pricing and more information.

Information furnished by Avnet Memec is believed to be accurate and reliable. Avnet Memec reserves the right to change specifications detailed in this data sheet at any time without notice, in order to improve reliability, function or design, and assumes no responsibility for any errors within this document. Avnet Memec does not make any commitment to update this information.

Avnet Memec assumes no obligation to correct any errors contained herein or to advise any user of this text of any correction, if such be made, nor does the Company assume responsibility for the functioning of undescribed features or parameters. Avnet Memec will not assume any liability for the accuracy or correctness of any support or assistance provided to a user.

Avnet Memec does not represent that products described herein are free from patent infringement or from any other third-party right. No license is granted by implication or otherwise under any patent or patent rights of Avnet Memec.

AvnetCore products are not intended for use in life support appliances, devices, or systems. Use of a AvnetCore product in such application without the written consent of the appropriate Avnet Design officer is prohibited.

All trademarks, registered trademarks, or service marks are property of their respective owners.

Contact Information:

North America

10805 Rancho Bernardo Road
Suite 100
San Diego, California 92127
United States of America
TEL: +1 858 385 7500
FAX: +1 858 385 7770

Europe, Middle East & Africa

Mattenstrasse 6a
CH-2555 Brügg BE
Switzerland
TEL: +41 0 32 374 32 00
FAX: +41 0 32 374 32 01

Ordering Information:

Part Number

MC-ACT-PL3LINK-NET
MC-ACT-PL3LINK-VHDL

Hardware

Actel PL3LINK Netlist
Actel PL3LINK VHDL

Resale

Contact for pricing
Contact for pricing



www.em.avnet.com/actel