

HiRel SX-A Family FPGAs

Features and Benefits

Leading Edge Performance

- 215 MHz System Performance (Military Temperature)
- 5.3 ns Clock-to-Out (Pin-to-Pin) (Military Temperature)
- 240 MHz Internal Performance (Military Temperature)

Specifications

- 48,000 to 108,000 Available System Gates
- Up to 228 User-Programmable I/O Pins
- Up to 2,012 Dedicated Flip-Flops
- 0.25/0.22 μ CMOS Process Technology

Features

- Hot-Swap Compliant I/Os
- Power-Up/Down Friendly (no sequencing required for supply voltages)
- Class B Level Devices
- Three Standard Hermetic Package Options

- Actel Secure Programming Technology with FuseLock™ Prevents Reverse Engineering and Design Theft
- Cold-Sparing Capability
- Individual Output Slew Rate Control
- QML Certified Devices
- 100% Military Temperature Tested (-55°C to +125°C)
- 33 MHz PCI Compliant
- CPLD and FPGA Integration
- Single-Chip Solution
- Configurable I/O Support for 3.3 V/5 V PCI, LVTTTL, and TTL
- Configurable Weak Resistor Pull-Up or Pull-Down for Tristated Outputs during Power-Up
- Up to 100% Resource Utilization and 100% Pin Locking
- 2.5 V, 3.3 V, and 5 V Mixed Voltage Operation with 5 V Input Tolerance and 5 V Drive Strength
- Very Low Power Consumption
- Deterministic, User-Controllable Timing
- Unique In-System Diagnostic and Verification Capability with Silicon Explorer II
- Boundary-Scan Testing in Compliance with IEEE 1149.1 (JTAG)

Product Profile

Device	A54SX32A	A54SX72A
Capacity		
Typical Gates	32,000	72,000
System Gates	48,000	108,000
Logic Modules	2,880	6,036
Combinatorial Cells	1,800	4,024
Register Cells		
Dedicated Flip-Flops	1,080	2,012
Maximum Flip-Flops	1,980	4,024
Maximum User I/Os	228	213
Global Clocks	3	3
Quadrant Clocks	0	4
Boundary-Scan Testing	Yes	Yes
3.3 V / 5 V PCI	Yes	Yes
Clock-to-Out	5.3 ns	6.7 ns
Input Set-Up (External)	0 ns	0 ns
Speed Grades	Std, -1	Std, -1
Package (by Pin Count)		
CQFP	84, 208, 256	208, 256

Ordering Information

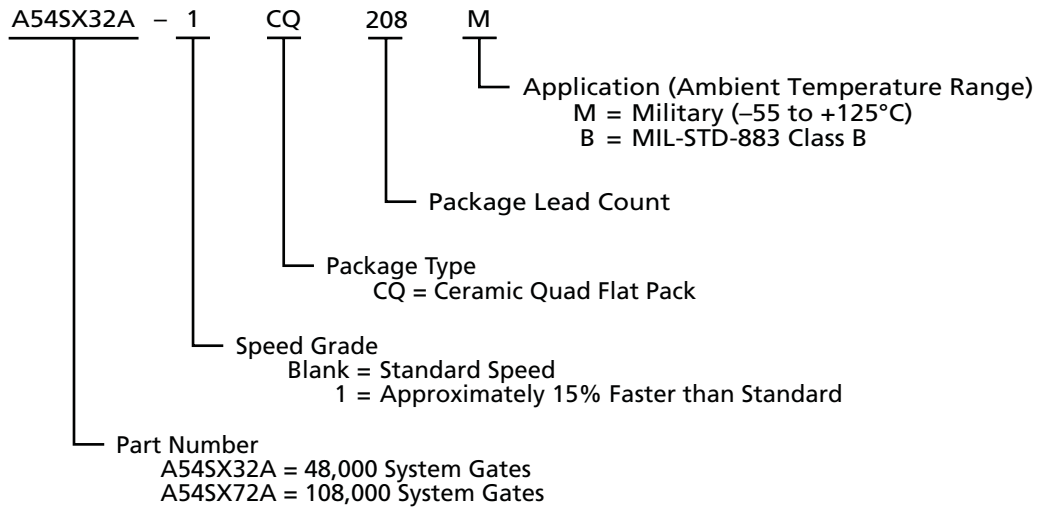

Figure 1 • HiRel SX-A Family Ordering Information

Ceramic Device Resources

Device	User I/Os (including clock buffers)		
	CQFP 84-Pin	CQFP 208-Pin	CQFP 256-Pin
A54SX32A	62	174	228
A54SX72A	–	171	213

Note: Package Definitions: CQFP = Ceramic Quad Flat Pack

Actel MIL-STD-883 Product Flow

Step	Screen	883 Method	883 – Class B Requirement
1.	Internal Visual	2010, Test Condition B	100%
2.	Temperature Cycling	1010, Test Condition C	100%
3.	Constant Acceleration	2001, Test Condition D, Y ₁ , Orientation Only	100%
4.	Seal a. Fine b. Gross	1014	100% 100%
5.	Visual Inspection	2009	100%
6.	Pre-Burn-In Electrical Parameters	In accordance with applicable Actel device specification	100%
7.	Burn-In Test	1015, Condition D, 160 hours @ 125°C or 80 hours @ 150°C	100%
8.	Interim (Post-Burn-In) Electrical Parameters	In accordance with applicable Actel device specification	100%
9.	Percent Defective Allowable	5%	All Lots
10.	Final Electrical Test a. Static Tests (1) 25°C (Subgroup 1, Table I) (2) –55°C and +125°C (Subgroups 2 and 3, Table I) b. Functional Tests (1) 25°C (Subgroup 7, Table I) (2) –55°C and +125°C (Subgroups 8A and 8B, Table I) c. Switching Tests at 25°C (Subgroup 9, Table I)	In accordance with applicable Actel device specification, which includes a, b, and c: 5005 5005 5005 5005 5005	100% 100% 100%
11.	External Visual	2009	100%

Table of Contents

General Description

QML Certification	1-1
HiRel SX-A Family Architecture	1-1
Other Architectural Features	1-5
Related Documents	1-9

Detailed Specifications

2.5 V/3.3 V/5 V Operating Conditions	1-10
5 V PCI Compliance for the HiRel SX-A Family	1-12
3.3 V PCI Compliance for the HiRel SX-A Family	1-14
Junction Temperature (T_J)	1-16
Package Thermal Characteristics	1-16
HiRel SX-A Timing Model	1-17
Timing Characteristics	1-20
Pin Description	1-31

Package Pin Assignments

84-Pin CQFP	2-1
208-Pin CQFP	2-3
256-Pin CQFP	2-6

Datasheet Information

List of Changes	3-1
Datasheet Categories	3-3
International Traffic in Arms Regulations (ITAR) and Export Administration Regulations (EAR)	3-3

General Description

The HiRel versions of Actel SX-A family FPGAs offer advantages for commercial applications and all types of military and high reliability equipment.

The HiRel versions are fully pin compatible, allowing designs to migrate across different applications that do not have radiation requirements. Additionally, the HiRel devices can be used as a lower cost prototyping tool for RadTolerant (RT) designs. This datasheet discusses HiRel SX-A products. Refer to the [Actel website](#) for more information concerning RadTolerant products.

The programmable architecture of these devices offers high performance, design flexibility, and fast and inexpensive prototyping, all without the expense of test vectors, NRE charges, long lead times, and schedule and cost penalties for design modifications that are often required by ASIC devices.

QML Certification

Actel has achieved full QML certification, demonstrating that quality management, procedures, processes, and controls are in place and comply with MIL-PRF-38535, the performance specification used by the Department of Defense for monolithic integrated circuits. QML certification is an example of the Actel commitment to supplying the highest quality products for all types of high reliability, military, and space applications.

Many suppliers of microelectronics components have implemented QML as their primary worldwide business system. Appropriate use of this system not only helps in the implementation of advanced technologies, but also allows for quality, reliable, and cost-effective logistics support throughout the life cycles of QML products.

HiRel SX-A Family Architecture

The HiRel SX-A family architecture was designed to satisfy next-generation performance and integration requirements for production volume designs in a broad range of applications.

Programmable Interconnect Element

The HiRel SX-A family incorporates either three (in HiRel A54SX32A) or four (in HiRel A54SX72A) layers of metal interconnect and provides efficient use of silicon by locating the routing interconnect resources between the top two metal layers ([Figure 1-1](#)). This completely eliminates the channels of routing and interconnect resources between logic modules (as implemented on SRAM FPGAs and previous generations of antifuse FPGAs) and enables the entire floor of the device to be spanned with an uninterrupted grid of logic modules.

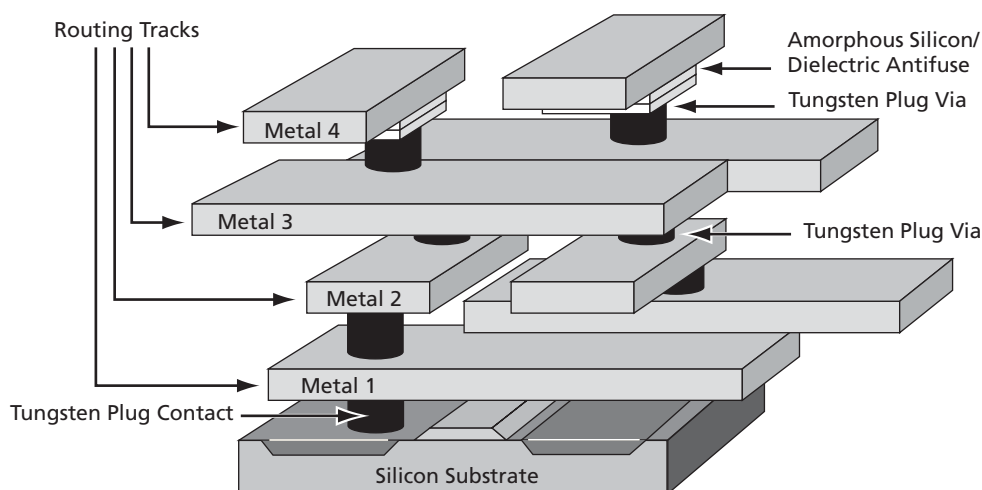

Note: HiRel A54SX72A has four layers of metal with the antifuse between Metal 3 and Metal 4. HiRel A54SX32A has three layers of metal with antifuse between Metal 2 and Metal 3.

Figure 1-1 • HiRel SX-A Family Interconnect Elements

Interconnection between these logic modules is achieved using Actel patented metal-to-metal programmable antifuse interconnect elements, which are embedded in the top two layers. The antifuses are normally open circuit and, when programmed, form a permanent low-impedance connection.

The extremely small size of these interconnect elements gives the HiRel SX-A family abundant routing resources and provides excellent protection against design theft. Reverse engineering is virtually impossible because it is extremely difficult to distinguish between programmed and unprogrammed antifuses. Additionally, since HiRel SX-A is a nonvolatile single-chip solution, there is no configuration bitstream to intercept.

The HiRel SX-A interconnect elements (the antifuses and metal tracks) also have lower capacitance and lower resistance than those of any other device of similar capacity, resulting in the fastest signal propagation in the industry for the radiation tolerance offered.

Logic Module Design

The HiRel SX-A family architecture is described as a "sea-of-modules" architecture because the entire floor of the device is covered with a grid of logic modules with virtually no chip area lost to interconnect elements or routing. Actel HiRel SX-A devices provide two types of logic modules: the register cell (R-cell) and the combinatorial cell (C-cell).

The R-cell (Figure 1-2) contains a flip-flop featuring asynchronous clear, asynchronous preset, and clock enable (using the S0 and S1 lines) control signals. The R-cell registers feature programmable clock polarity selectable on a register-by-register basis.

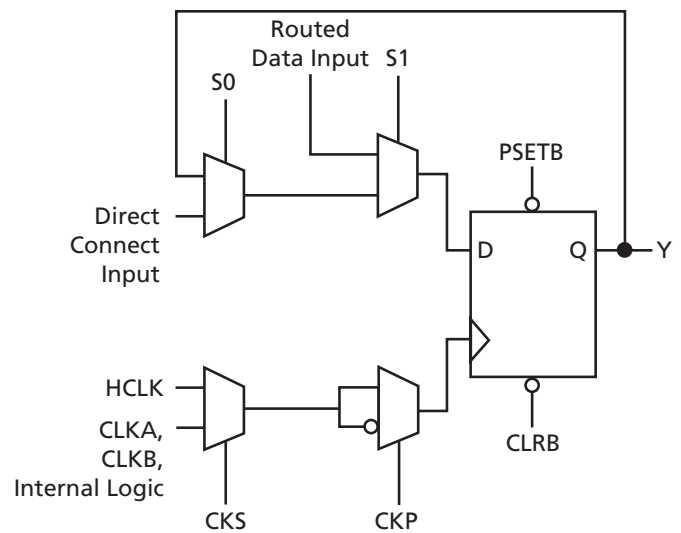

Figure 1-2 • R-Cell

This provides additional flexibility while allowing the mapping of synthesized functions into the HiRel SX-A FPGA. The clock source for the R-cell can be chosen from the hardwired clock, the routed clocks, or internal logic.

The C-cell implements a range of combinatorial functions up to five inputs (Figure 1-3). Inclusion of the DB input and its associated inverter function increases the number of combinatorial functions that can be implemented in a single module from 800 options (as in previous architectures) to more than 4,000 in the HiRel SX-A architecture. An example of the improved flexibility enabled by the inversion capability is the ability to implement a three-input exclusive-OR function into a single C-cell. This facilitates construction of 9-bit parity-tree functions with 1.9 ns of propagation delay. At the same time, the C-cell structure is extremely synthesis friendly, simplifying the overall design and reducing synthesis time.

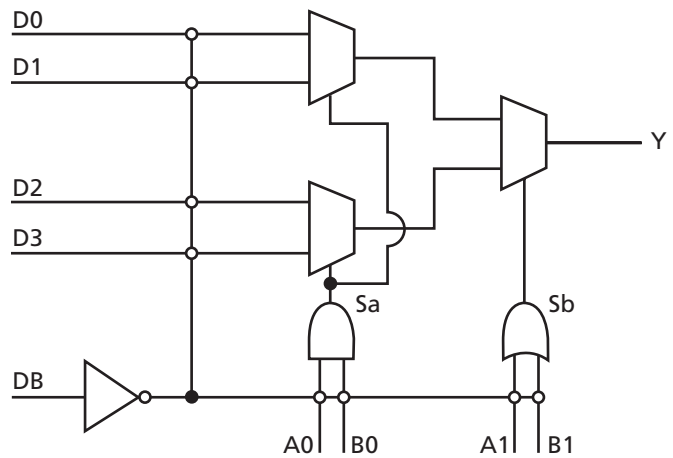

Figure 1-3 • C-Cell

Chip Architecture

The HiRel SX-A family chip architecture provides a unique approach to module organization and chip routing that delivers the best register/logic mix for a wide variety of new and emerging applications.

Module Organization

Actel has arranged all C-cell and R-cell logic modules into horizontal banks called clusters. There are two type of clusters: Type 1 clusters contain two C-cells and one R-cell, and Type 2 clusters contain one C-cell and two R-cells.

To increase design efficiency and device performance, Actel has further organized these modules into SuperClusters (Figure 1-4 on page 1-3). A Type 1 SuperCluster is a two-wide grouping of Type 1 clusters. A

Type 2 SuperCluster is a two-wide group containing one Type 1 cluster and one Type 2 cluster. HiRel SX-A devices feature more Type 1 SuperCluster modules than Type 2 SuperCluster modules because designers typically require significantly more combinatorial logic than flip-flops.

Routing Resources

Clusters and SuperClusters can be connected through the use of two innovative local routing resources called FastConnect and DirectConnect, which enable extremely fast and predictable interconnection of modules within clusters and SuperClusters (Figure 1-5 on page 1-4 and Figure 1-6 on page 1-4). This routing architecture also dramatically reduces the number of antifuses required to complete a circuit, ensuring the highest possible performance.

DirectConnect is a horizontal routing resource that provides connections from a C-cell to its neighboring R-cell in a given SuperCluster. DirectConnect uses a

hardwired signal path requiring no programmable interconnection to achieve its fast signal propagation time of less than 0.1 ns.

FastConnect enables horizontal routing between any two logic modules within a single SuperCluster and vertical routing to the SuperCluster immediately below it. Only one programmable connection is used in a FastConnect path, delivering a maximum pin-to-pin propagation time of 0.3 ns.

In addition to DirectConnect and FastConnect, the architecture makes use of two globally oriented routing resources known as segmented routing and high-drive routing. The Actel segmented routing structure provides a variety of track lengths for extremely fast routing between SuperClusters. The exact combination of track lengths and antifuses within each path is chosen by the 100 percent automatic place-and-route software to minimize signal propagation delays.

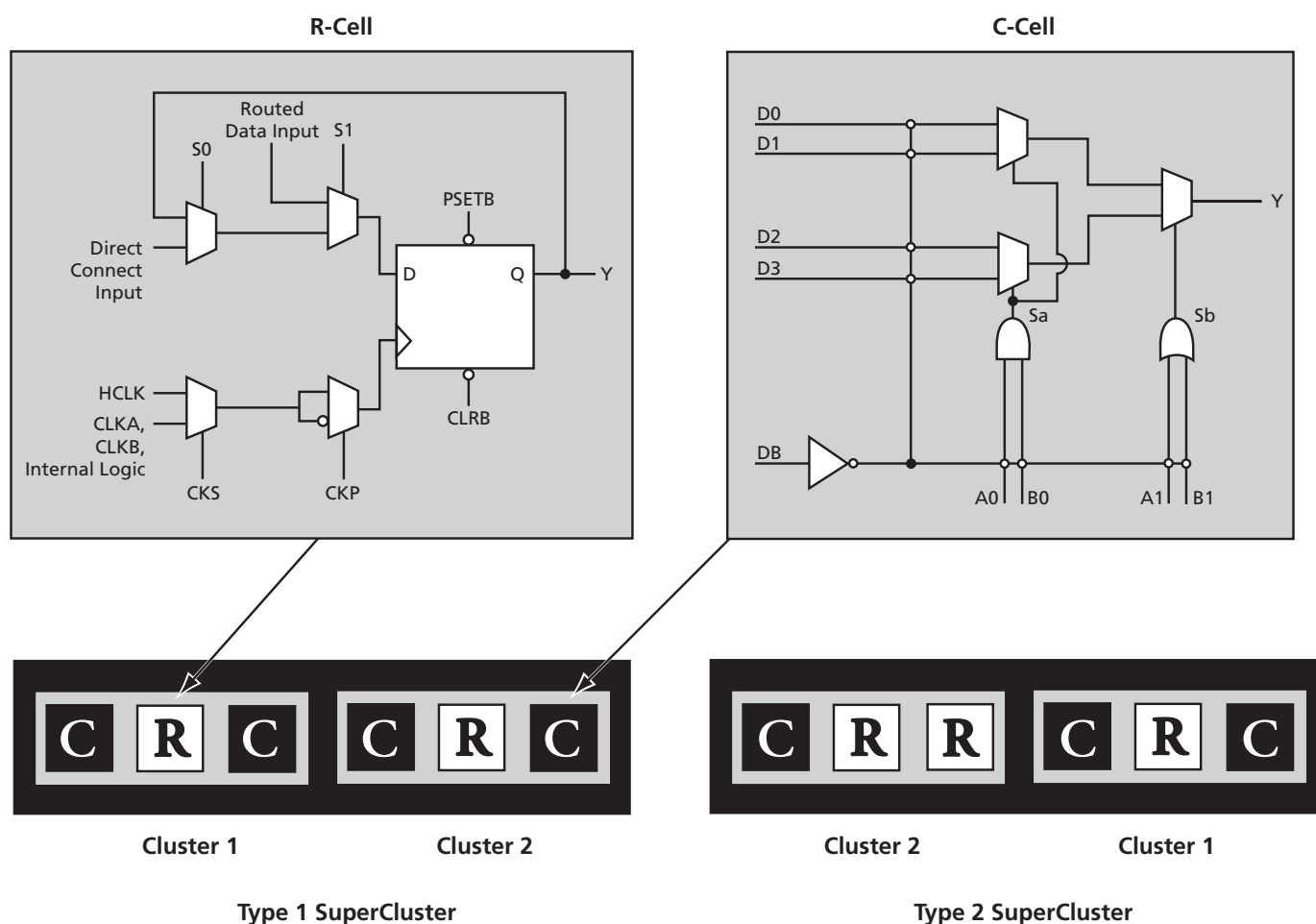

Figure 1-4 • Cluster Organization

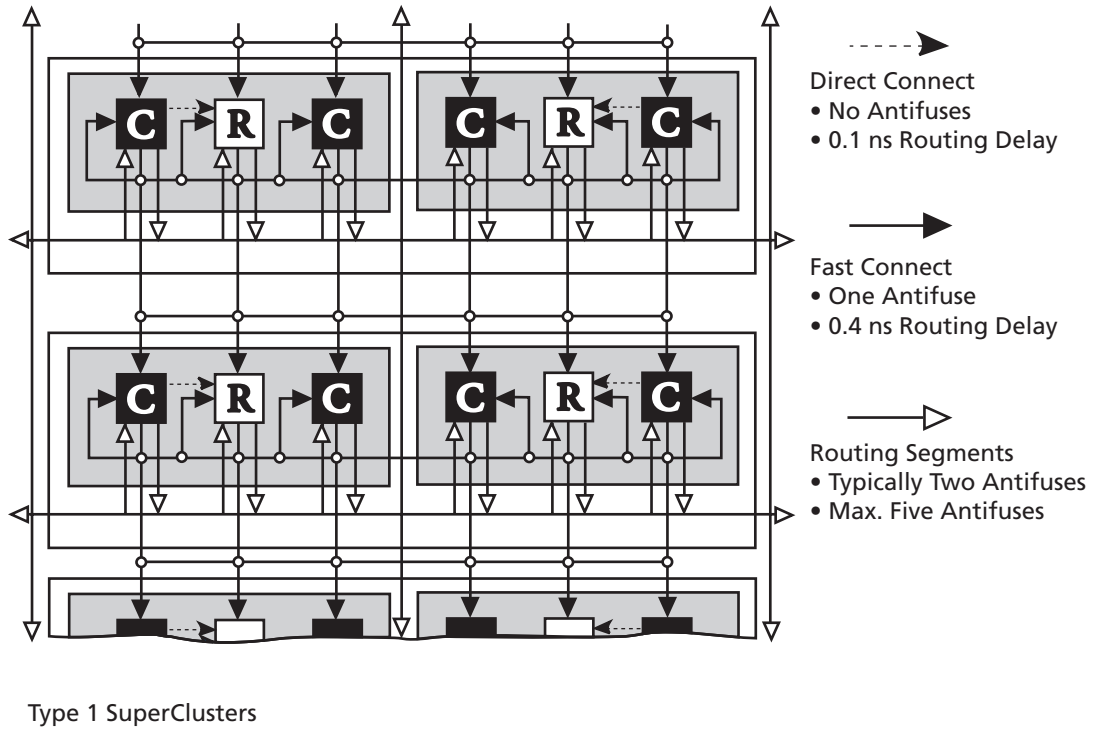

Figure 1-5 • DirectConnect and FastConnect for Type 1 SuperClusters

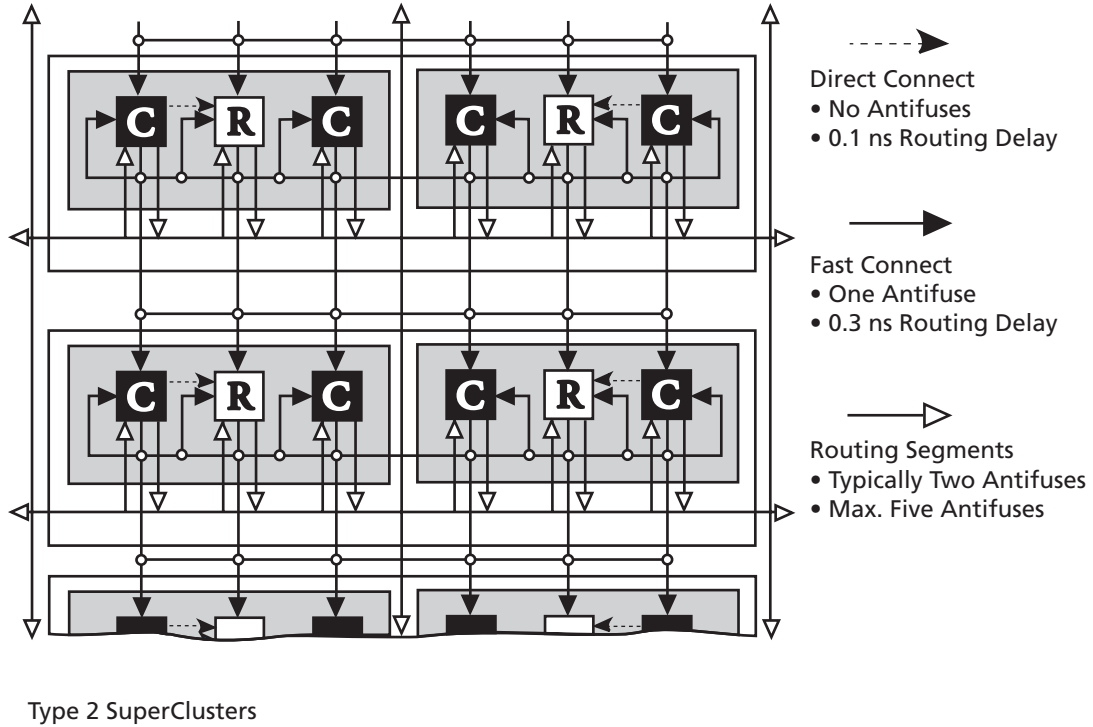

Figure 1-6 • DirectConnect and FastConnect for Type 2 SuperClusters

Clock Resources

The Actel high-drive routing structure provides up to three clock networks (Table 1-1). The first clock, called HCLK, is hardwired from the HCLK buffer to the clock select MUX in each R-cell. HCLK cannot be connected to combinatorial logic. This results in a fast propagation path for the clock signal, enabling the 5.3 ns clock-to-out (pad-to-pad) performance of the HiRel SX-A devices. The hardwired clock is tuned to provide clock skew of less than 0.3 ns worst case. If not used, this pin must be set as LOW or HIGH on the board. It must not be left floating. Figure 1-7 shows the clock circuit used for the HCLK.

Table 1-1 • HiRel SX-A Clock Resources

	HiRel A54SX32A	HiRel A54SX72A
Hardwired Clocks (HCLK)	1	1
Routed Clocks (CLKA, CLKB)	2	2
Quadrant Clocks (QCLKA, QCLKB, QCLKC, QCLKD)	0	4

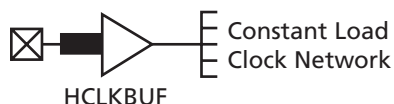
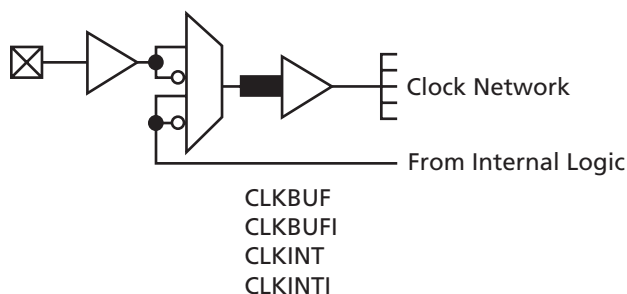

Figure 1-7 • HiRel SX-A Hardwired Load Clock Pad

The two routed clocks (CLKA and CLKB) are global clocks that can be sourced from external pins or from internal logic signals within the HiRel SX-A device. CLKA and CLKB may be connected to sequential cells or to combinatorial logic. If the CLKA or CLKB pins are not used or sourced from signals, then these pins must be set as LOW or HIGH on the board. They must not be left floating, except in HiRel A54SX72A, where they can be configured as regular I/Os. Figure 1-8 shows the CLKA and CLKB circuit used in HiRel A54SX32A.



Note: This does not include the clock pad for HiRel A54SX72A.

Figure 1-8 • HiRel SX-A Routed Clock Pads

In addition, the HiRel A54SX72A device provides four quadrant clocks (QCLKA, QCLKB, QCLKC, and QCLKD), which can be sourced from external pins or from internal logic signals within the device. Each of these clocks can individually drive up to a quarter of the chip, or they can be grouped together to drive multiple quadrants. If QCLKs are not used as quadrant clocks, they will behave as regular I/Os. The CLKA, CLKB, and QCLK circuits for HiRel A54SX72A are shown in Figure 1-9. For more information, refer to the "Pin Description" section on page 1-31.

For more information on how to use quadrant clocks in HiRel A54SX72A, refer to the Actel *Global Clock Networks in Actel Antifuse Devices* application note.

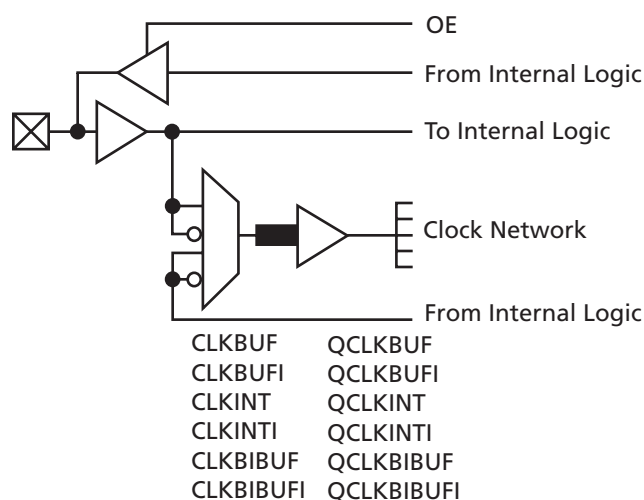

Figure 1-9 • HiRel A54SX72A CLKA/CLKB/QCLK Pads

Other Architectural Features

Technology

The Actel HiRel SX-A family is implemented in a high-voltage twin-well CMOS using 0.25 μm design rules. The metal-to-metal antifuse is made up of a combination of amorphous silicon and dielectric material with barrier metals. It also has a programmed ("on" state) resistance of 25 Ω with a capacitance of 1.0 fF for low signal impedance.

Performance

The combination of architectural features described above allows HiRel SX-A devices to operate with internal clock frequencies of 240 MHz, enabling very fast execution of complex logic functions. Thus, the HiRel SX-A family is an optimal platform upon which to integrate the functionality previously contained in multiple CPLDs.

In addition, designs that previously would have required a gate array to meet performance goals can now be integrated into a HiRel SX-A device with dramatic improvements in cost and time-to-market. Using timing-driven place-and-route tools, designers can achieve highly deterministic device performance. With HiRel SX-A devices, designers do not need to use complicated performance-enhancing design techniques, such as redundant logic to reduce fanout on critical nets or the instantiation of macros in HDL code to achieve high performance.

I/O Modules

Each I/O on a HiRel SX-A device can be configured as an input, an output, a tristate output, or a bidirectional pin. Mixed I/O standards are allowed, and can be set on an individual basis. Even without the inclusion of dedicated I/O registers, these I/Os, in combination with array registers, can achieve clock-to-output-pad timing as fast as 4.1 ns. In most FPGAs, I/O cells that have embedded latches and flip-flops require instantiation in HDL code; this is a design complication not encountered in HiRel SX-A FPGAs. Fast pin-to-pin timing ensures the device will have little trouble interfacing with any other device in the system, which in turn enables parallel design of

system components and reduces overall design time. All unused I/Os are configured as tristate outputs by the Designer software. Each I/O module has an available power-up resistor of approximately 50 kΩ that can configure the I/O to a known state during power-up. Just slightly before V_{CCA} reaches 2.5 V, the resistors are disabled so the I/Os will behave normally. For more information about the power-up resistors, see the Actel application note *Actel SX-A and RT54SX-S Devices in Hot-Swap and Cold-Sparing Applications*. See Table 1-2 and Table 1-3 for more information on I/O features.

HiRel SX-A inputs should be driven by high-speed push-pull devices with a low resistance pull-up device. If the input voltage is greater than V_{CCI} and a fast push-pull device is not used, the high-resistance pull-up of the driver and the internal circuitry of the HiRel SX-A I/O, may create a voltage divider. This voltage divider could pull the input voltage below specification for some devices connected to the driver. A logic '1' may not be correctly presented in this case. For example, if an open drain driver is used with a pull-up resistor to 5 V to provide the logic '1' input, and V_{CCI} is set to 3.3 V on the HiRel SX-A device, the input signal may be pulled down by the HiRel SX-A input.

Table 1-2 • I/O Features

Function	Description
Two Input Buffer Threshold Selections	<ul style="list-style-type: none"> 5 V: PCI, TTL 3.3 V: PCI, LVTTTL
Flexible Output Driver	<ul style="list-style-type: none"> 5 V: PCI, TTL 3.3 V: PCI, LVTTTL
Output Buffer	Hot-Swap Capability (3.3 V PCI is not hot-swappable) <ul style="list-style-type: none"> I/O on an unpowered device does not sink current Can be used for cold sparing Selectable on an individual I/O basis Individually selectable slew rate, high-slew or low-slew (the default is high slew rate). The slew is only affected on the falling edge of an output. No slew is changed on the rising edge of the output or any inputs.
Power-Up	Individually selectable pull-ups and pull-downs during power-up (default is to power-up tristate) Enables deterministic power-up of device V_{CCA} and V_{CCI} can be powered in any order

Table 1-3 • I/O Characteristics for All I/O Configurations

	Hot-Swappable	Slew Rate Control	Power-Up Resistor Pull
TTL, LVTTTL	Yes	Yes. Affects falling edge outputs only.	Pull-up or pull-down
3.3 V PCI	No	No. High slew rate only.	Pull-up or pull-down
5 V PCI	Yes	No. High slew rate only.	Pull-up or pull-down

Hot-Swapping

HiRel SX-A I/Os can be configured to be hot-swappable in compliance with the Compact PCI Specification. However, a 3.3 V PCI device is not hot-swappable. During power-up/down, all I/Os are tristated. V_{CCA} and V_{CCI} do not have to be stable during power-up/down. After the HiRel SX-A device is plugged into an electrically active system, it will not degrade the reliability of or cause damage to the host system. The device's output pins are driven to a high impedance state until normal chip

operating conditions are reached. Table 1-4 summarizes the V_{CCA} voltage at which the I/Os behave according to the user's design for a HiRel SX-A device at room temperature for various ramp-up rates. The data reported assumes a linear ramp-up profile to 2.5 V. Refer to the Actel application note *Actel SX-A and RT54SX-S Devices in Hot-Swap and Cold-Sparing Applications* for more information on hot-swapping.

Table 1-4 • Power-Up Time at which I/Os Become Active

Ramp Rate	0.25 V/ μ s	0.025 V/ μ s	5 V/ms	2.5 V/ms	0.5 V/ms	0.25 V/ms	0.1 V/ms	0.025 V/ms
Units	μ s	μ s	ms	ms	ms	ms	ms	ms
HiRel A54SX32A	10	100	0.46	0.74	2.8	5.2	12.1	47.2
HiRel A54SX72A	10	100	0.41	0.67	2.6	5.0	12.1	47.2

Power Requirements

The HiRel SX-A family supports 2.5 V/3.3 V/5 V mixed-voltage operation and is designed to tolerate 5 V inputs for all standards except 3.3 V PCI. In PCI mode, I/Os support 3.3 V or 5 V, and input tolerance depends on V_{CCI} . Refer to Table 1-8 on page 1-11 and Table 1-10 on page 1-12 for more information. Power consumption is extremely low due to the very short distances signals are required to travel to complete a circuit. Power requirements are further reduced due to the small number of antifuses in the path and the low-resistance properties of the antifuses. The antifuse architecture does not require active circuitry to hold a charge (as do SRAM or EPROM), making it the lowest-power architecture on the market.

Boundary Scan Testing (BST)

All HiRel SX-A devices are IEEE 1149.1 compliant. HiRel SX-A devices offer superior diagnostic and testing capabilities by providing BST and probing capabilities. The BST function is controlled through the special JTAG pins (TMS, TDI, TCK, TDO, and TRST). The functionality of the JTAG pins is defined by one of two available modes: Dedicated and Flexible (Table 1-5). TMS cannot be employed as a user I/O in either mode.

Table 1-5 • Boundary Scan Pin Functionality

Program Fuse Blown (Dedicated Test Mode)	Program Fuse Not Blown (Flexible Mode)
TCK, TDI, TDO are dedicated BST pins.	TCK, TDI, TDO are flexible and may be used as I/Os.
No need for pull-up resistor for TMS.	Use a pull-up resistor of 10 k Ω on TMS.

Configuring Diagnostic Pins

The JTAG and probe pins (TDI, TCK, TMS, TDO, PRA, and PRB) are placed in the desired mode by selecting the appropriate check boxes in the **Variation** dialog window. This dialog window is accessible through the Design Setup Wizard under the Tools menu in the Actel Designer software.

If JTAG I/Os (except TMS) are not programmed as dedicated JTAG I/Os, they can be used as regular I/Os.

TRST Pin

When the **Reserve JTAG Test Reset** box is checked, the TRST pin will become a Boundary Scan Reset pin. In this mode, the TRST pin functions as a dedicated, asynchronous, active low input to initialize or reset the BST circuit. An internal pull-up resistor will be enabled automatically on the TRST pin.

The TRST pin will function as a user I/O when the **Reserve JTAG Test Reset** check box is cleared. The internal pull-up resistor will be disabled in this mode.

Dedicated Test Mode

When the **Reserve JTAG** box is checked in the Designer software, the HiRel SX-A device is placed in Dedicated Test mode, which configures the TDI, TCK, and TDO pins for BST or in-circuit verification with Silicon Explorer II. An internal pull-up resistor is automatically enabled on both the TMS and TDI pins. In Dedicated Test mode, TCK, TDI, and TDO are dedicated test pins and become unavailable for pin assignment in the Pin Editor. The TMS pin will function as specified in the IEEE 1149.1 (JTAG) specification.

Flexible Mode

When the **Reserve JTAG** box is not selected, the HiRel SX-A device is placed in flexible mode, which allows the TDI, TCK, and TDO pins to function as user I/Os or BST pins. In this mode, the internal pull-up resistors on the TMS and TDI pins are disabled. An external 10 k Ω pull-up resistor to V_{CC1} is required on the TMS pin.

The TDI, TCK, and TDO pins are transformed from user I/Os to BST pins when a rising edge on TCK is detected while TMS is at logical LOW. Once the BST pins are in test mode, they will remain in BST mode until the internal BST state machine reaches the "logic reset" state. At this point the BST pins will be released and will function as regular I/O pins. The "logic reset" state is reached five TCK cycles after the TMS pin is set to logical HIGH.

Development Tool Support

HiRel SX-A devices are fully supported by the Actel line of FPGA development tools, including the Actel Designer software and Actel Libero[®] Integrated Design Environment (IDE). Designer software, the Actel suite of FPGA development tools for PCs and Workstations, includes the ACTgen Macro Builder, timing-driven place-and-route, timing analysis tools, and fuse file generation. Libero IDE is a design management environment that integrates the needed design tools, streamlines the design flow, manages all design and log files, and passes necessary design data between tools. Libero IDE includes

Synplify[®], ViewDraw[®], the Actel Designer software, ModelSim[®] HDL Simulator, WaveFormer Lite[™], and Actel Silicon Explorer II.

HiRel SX-A Probe Circuit Control Pins

The Silicon Explorer II tool uses the boundary scan ports (TDI, TCK, TMS, and TDO) to select the desired nets for verification. The selected internal nets are assigned to the PRA/PRB pins for observation. Figure 1-10 illustrates the interconnection between Silicon Explorer II and the FPGA when performing in-circuit verification. The TRST pin is equipped with an internal pull-up resistor from the reset state during probing. It is recommended that TRST be left floating.

Design Considerations

Avoid using the TDI, TCK, TDO, PRA, and PRB pins as input or bidirectional ports. Since these pins are active during probing, critical input signals through these pins are not available. In addition, do not program the Security Fuse, as this disables the Probe Circuit. Actel recommends that you use a series 70 Ω termination resistor on every probe connector (TDI, TCK, TMS, TDO, PRA, and PRB). The 70 Ω termination is used to prevent data transmission corruption during probing and reading back the checksum.

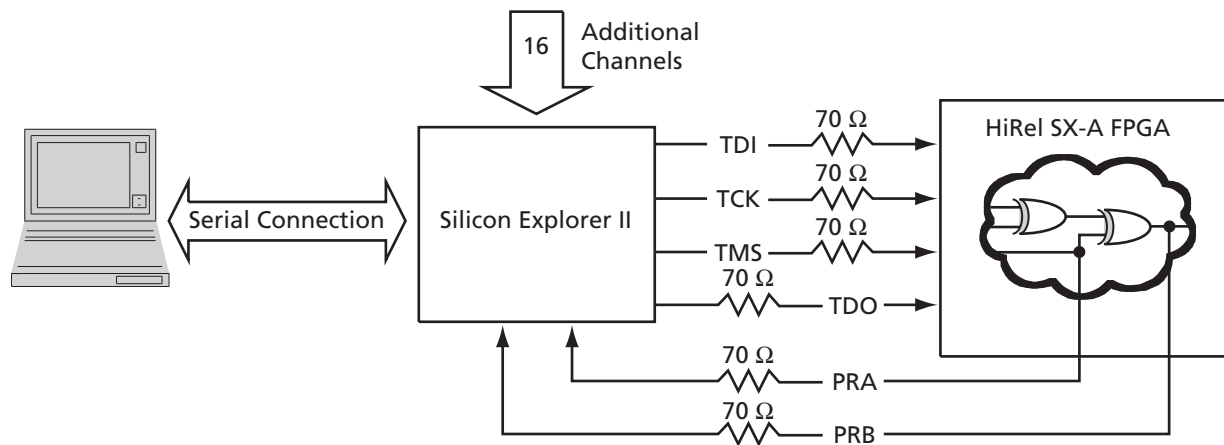

Figure 1-10 • Probe Setup

Related Documents

Application Notes

Global Clock Networks in Actel Antifuse Devices

www.actel.com/documents/GlobalClk_AN.pdf

Actel SX-A and RT54SX-S Devices in Hot-Swap and Cold-Sparing Applications

www.actel.com/documents/HotSwapColdSparing_AN.pdf

Datasheets

SX-A Family FPGAs

www.actel.com/documents/SXA_DS.pdf

Detailed Specifications

2.5 V/3.3 V/5 V Operating Conditions

Table 1-6 • Absolute Maximum Ratings¹

Symbol	Parameter	Limits	Units
V_{CCI}	DC Supply Voltage	-0.3 to +6.0	V
V_{CCA} ²	AC Supply Voltage	-0.3 to +3.5	V
V_{CCA}	DC Supply Voltage	-0.3 to +3.0	V
V_I	Input Voltage	-0.5 to +6.0	V
V_O ³	Output Voltage	-0.5 to $+V_{CCI} + 0.5$	V
T_{STG}	Storage Temperature	-65 to +150	°C

Notes:

1. Stresses beyond those listed under "Absolute maximum Ratings" may cause permanent damage to the device. Exposure to absolute maximum rated conditions for extended periods may affect device reliability. Devices should not be operated outside the Recommended Operating Conditions.
2. The AC transient V_{CCA} limit is for transients of less than 10 μ s duration and is not intended for repetitive use. Transients must not exceed 10 hours total duration over the lifetime of the part. Core voltage spikes from a single transient will not negatively impact the reliability of the device if, for this nonrepetitive event, the transient does not exceed 3.5 V at any time and the time that the transient exceeds 2.75 V does not exceed 10 μ s in duration.
3. V_O max for 3.3 V PCI is $V_{CCI} + 0.5$ V. For other I/O standards V_O max is 6.0 V.

Table 1-7 • Recommended Operating Conditions

Parameter	Military	Units
Temperature Range*	-55 to +125	°C
V_{CCA} 2.5 V Power Supply Range	2.25 to 2.75	V
V_{CCI} 3.3 V Power Supply Range	3.0 to 3.6	V
V_{CCI} 5 V Power Supply Range	4.5 to 5.5	V

Note: *Ambient temperature (T_A) is used for commercial and industrial; case temperature (T_C) is used for military.

Table 1-8 • 3.3 V LVTTTL and 5 V TTL Electrical Specifications

Symbol	Parameter	Military		Units
		Min.	Max.	
V _{OH}	V _{DD} = MIN, V _I = V _{IH} or V _{IL} (I _{OH} = -1 mA)	0.9V _{CC1}		V
	V _{DD} = MIN, V _I = V _{IH} or V _{IL} (I _{OH} = -8 mA)	2.4		V
V _{OL}	V _{DD} = MIN, V _I = V _{IH} or V _{IL} (I _{OL} = 1 mA)		0.1V _{CC1}	V
	V _{DD} = MIN, V _I = V _{IH} or V _{IL} (I _{OL} = 12 mA)		0.4	V
V _{IL} ¹	Input Low Voltage		0.8	V
V _{IH} ²	Input High Voltage	2.0		V
I _{IL} / I _{IH}	Input Leakage Current, V _{IN} = V _{CC1} or GND	-20	+20	μA
I _{OZ}	Tristate Output Leakage Current, V _{OUT} = V _{CC1} or GND	-20	+20	μA
t _R , t _F	Input Transition Time t _R , t _F		10	ns
C _{IO}	I/O Capacitance	20	10	pF
I _{CC}	Standby Current		25	mA
IV Curve ³	Can be derived from the IBIS model on the web			

Notes:

1. For AC signals, the input signal may undershoot during transitions to -1.2 V for no longer than 11 ns. Current during the transition must not exceed 95 mA.
2. For AC signals, the input signal may overshoot during transitions to V_{CC1} + 1.2 V for no longer than 11 ns. Current during the transition must not exceed 95 mA.
3. The IBIS model can be found at www.actel.com/techdocs/models/libis.html.
4. See the *SX-A Family FPGAs* datasheet for more information on commercial devices.

Table 1-9 • Maximum Source and Sink Currents for All I/O Standards

I/O Standard	Max. Source Current		Max. Sink Current	
	Min. V _{OH}	I(typ) (mA)	Max. V _{OL}	I(typ) (mA)
5 V TTL	2.4 V	-139	0.4 V	46
	0.9V _{CC1}	-35	0.1V _{CC1}	56
3.3 V LVTTTL	2.4 V	-43	0.4 V	39
	0.9V _{CC1}	-18	0.1V _{CC1}	32
5 V PCI	2.4 V	-139	0.55 V	61.5
3.3 V PCI	0.9V _{CC1}	-20	0.1V _{CC1}	38

Note: This information is derived from the IBIS model and was taken under typical conditions. The numbers do not include derating for package resistance.

5 V PCI Compliance for the HiRel SX-A Family

The HiRel SX-A family supports 3.3 V and 5 V PCI and is compliant with the PCI Local Bus Specification Rev. 2.1.

Table 1-10 • DC Specifications, 5 V PCI Operation

Symbol	Parameter	Condition	Min.	Max.	Units
V_{CCA}	Supply Voltage for Array		2.25	2.75	V
V_{CCI}	Supply Voltage for I/Os		4.5	5.5	V
V_{IH}	Input High Voltage ¹		2.0	$V_{CCI} + 0.5$	V
V_{IL}	Input Low Voltage ¹		-0.5	0.8	V
I_{IH}	Input High Leakage Current	$V_{IN} = 2.7$		70	μ A
I_{IL}	Input Low Leakage Current	$V_{IN} = 0.5$		-70	μ A
V_{OH}	Output High Voltage	$I_{OUT} = -2$ mA	2.4		V
V_{OL}	Output Low Voltage ²	$I_{OUT} = 3$ mA, 6 mA		0.55	V
C_{IN}	Input Pin Capacitance ³			10	pF
C_{CLK}	CLK Pin Capacitance		5	12	pF

Notes:

1. Input leakage currents include hi-Z output leakage for all bidirectional buffers with tristate outputs.
2. Signals without pull-up resistors must have 3 mA low output current. Signals requiring pull-up must have 6 mA; the latter includes FRAME#, IRDY#, TRDY#, DEVSEL#, STOP#, SERR#, PERR#, LOCK#, and when used, AD[63:32], C/BE[7:4]#, PAR64, REQ64#, and ACK64#.
3. Absolute maximum pin capacitance for a PCI input is 10 pF (except for CLK).

Figure 1-11 shows the 5 V PCI V/I curve and the minimum and maximum PCI drive characteristics of the HiRel SX-A family.

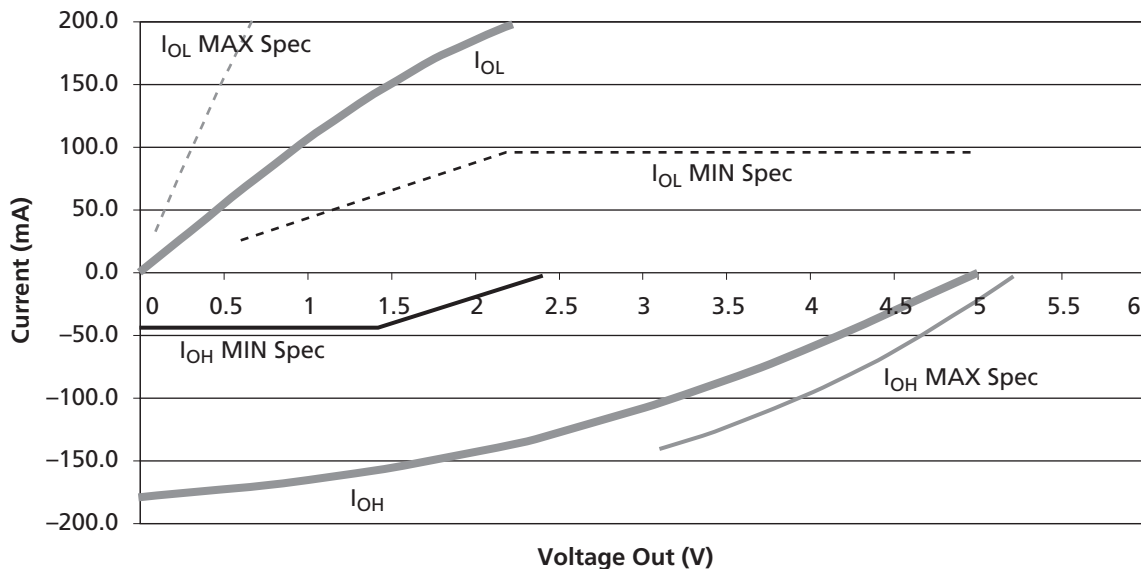

Figure 1-11 • 5 V PCI Curve for HiRel SX-A Family

Table 1-11 • AC Specifications, 5 V PCI Operation

Symbol	Parameter	Condition	Min.	Max.	Units
$I_{OH(AC)}$	Switching Current High	$0 < V_{OUT} \leq 1.4$ ¹	-44		mA
		$1.4 \leq V_{OUT} < 2.4$ ^{1, 2}	$(-44 + (V_{OUT} - 1.4)/0.024)$		mA
		$3.1 < V_{OUT} < V_{CCI}$ ^{1, 3}		EQ 1-1 on page 1-13	
	(Test Point)	$V_{OUT} = 3.1$ ³		-142	mA
$I_{OL(AC)}$	Switching Current Low	$V_{OUT} \geq 2.2$ ¹	95		mA
		$2.2 > V_{OUT} > 0.55$ ¹	$V_{OUT}/0.023$		mA
		$0.71 > V_{OUT} > 0$ ^{1, 3}		EQ 1-2 on page 1-13	
	(Test Point)	$V_{OUT} = 0.71$ ³		206	mA
I_{CL}	Low Clamp Current	$-5 < V_{IN} \leq -1$	$-25 + (V_{IN} + 1)/0.015$		mA
$slew_R$	Output Rise Slew Rate	$0.4\text{ V} - 2.4\text{ V load}$ ⁴	1	5	V/ns
$slew_F$	Output Fall Slew Rate	$2.4\text{ V} - 0.4\text{ V load}$ ⁴	1	5	V/ns

Notes:

1. Refer to the V/I curves in Figure 1-11 on page 1-12. Switching current characteristics for REQ# and GNT# are permitted to be one-half of that specified here; i.e., half-size output drivers may be used on these signals. This specification does not apply to CLK and RST#, which are system outputs. "Switching Current High" specifications are not relevant to SERR#, INTA#, INTB#, INTC#, or INTD#, which are open drain outputs.
2. Note that this segment of the minimum current curve is drawn from the AC drive point directly to the DC drive point, rather than toward the voltage rail (as is done in the pull-down curve). This difference is intended to allow for an optional N-channel pull-up.
3. Maximum current requirements must be met as drivers pull beyond the last step voltage. EQ 1-1 and EQ 1-2 define these maxima. The equation defined maximum should be met by the design. In order to facilitate component testing, a maximum current test point is defined for each side of the output driver.
4. This parameter is to be interpreted as the cumulative edge rate across the specified range, rather than the instantaneous rate at any point within the transition range. The specified load (Figure 1-12) is optional; i.e., the designer may elect to meet this parameter with an unloaded output per revision 2.0 of the PCI Local Bus Specification. However, adherence to both maximum and minimum parameters is now required (the maximum is no longer simply a guideline). Since adherence to the maximum slew rate was not required prior to revision 2.1 of the specification, there may be components on the market for some time yet that have faster edge rates. Therefore, motherboard designers must bear in mind that rise and fall times faster than this specification could occur, and they should ensure that signal integrity modeling accounts for this. Rise in slew rate does not apply to open drain outputs.

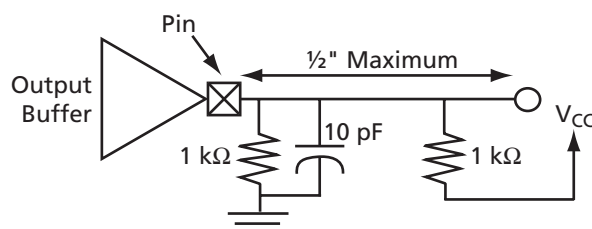

Figure 1-12 • 5 V PCI Slew Load

$$I_{OH} = 11.9 * (V_{OUT} - 5.25) * (V_{OUT} + 2.45)$$

for $V_{CCI} > V_{OUT} > 3.1\text{ V}$

EQ 1-1

$$I_{OL} = 78.5 * V_{OUT} * (4.4 - V_{OUT})$$

for $0\text{ V} < V_{OUT} < 0.71\text{ V}$

EQ 1-2

3.3 V PCI Compliance for the HiRel SX-A Family

The HiRel SX-A family supports 3.3 V and 5 V PCI and is compliant with the PCI Local Bus Specification Rev. 2.1.

Table 1-12 • DC Specifications, 3.3 V PCI Operation

Symbol	Parameter	Condition	Min.	Max.	Units
V_{CCA}	Supply Voltage for Array		2.25	2.75	V
V_{CCI}	Supply Voltage for I/Os		3.0	3.6	V
V_{IH}	Input High Voltage		$0.5V_{CCI}$	$V_{CCI} + 0.5$	V
V_{IL}	Input Low Voltage		-0.5	$0.3V_{CCI}$	V
I_{IPU}	Input Pull-Up Voltage ¹		$0.7V_{CCI}$		V
I_{IL}	Input Leakage Current ²	$0 < V_{IN} < V_{CCI}$		± 20	μA
V_{OH}	Output High Voltage	$I_{OUT} = -500 \mu A$	$0.9V_{CCI}$		V
V_{OL}	Output Low Voltage	$I_{OUT} = 1500 \mu A$		$0.1V_{CCI}$	V
C_{IN}	Input Pin Capacitance ³			10	pF
C_{CLK}	CLK Pin Capacitance		5	12	pF

Notes:

1. This specification should be guaranteed by design. It is the minimum voltage to which pull-up resistors are calculated to pull a floating network. Applications sensitive to static power utilization should ensure that the input buffer conducts minimal current at this input voltage.
2. Input leakage currents include hi-Z output leakage for all bidirectional buffers with tristate outputs.
3. Absolute maximum pin capacitance for a PCI input is 10 pF (except for CLK).

Figure 1-13 shows the 3.3 V PCI V-I curve and the minimum and maximum PCI drive characteristics of the HiRel SX-A family.

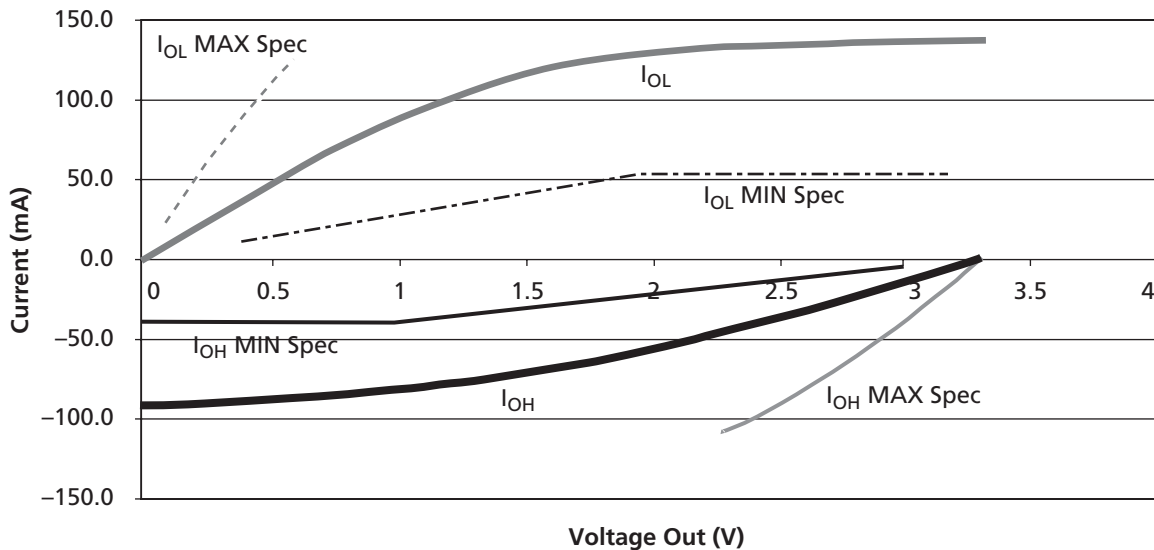

Figure 1-13 • 3.3 V PCI V-I Curve for HiRel SX-A Family

Table 1-13 • AC Specifications, 3.3 V PCI Operation

Symbol	Parameter	Condition	Min.	Max.	Units
$I_{OH(AC)}$	Switching Current High	$0 < V_{OUT} \leq 0.3V_{CC1}$ ¹	$-12V_{CC1}$		mA
		$0.3V_{CC1} \leq V_{OUT} < 0.9V_{CC1}$ ¹	$-17.1 + (V_{CC1} - V_{OUT})$		mA
		$0.7V_{CC1} < V_{OUT} < V_{CC1}$ ^{1,2}		EQ 1-3	
	(Test Point)	$V_{OUT} = 0.7V_{CC}$ ²		$-32V_{CC1}$	mA
$I_{OL(AC)}$	Switching Current Low	$V_{CC1} > V_{OUT} \geq 0.6V_{CC1}$ ¹	$16V_{CC1}$		mA
		$0.6V_{CC1} > V_{OUT} > 0.1V_{CC1}$ ¹	$26.7V_{OUT}$		mA
		$0.18V_{CC1} > V_{OUT} > 0$ ^{1,2}		EQ 1-4	
	(Test Point)	$V_{OUT} = 0.18V_{CC}$ ²		$38V_{CC1}$	mA
I_{CL}	Low Clamp Current	$-3 < V_{IN} \leq -1$	$-25 + (V_{IN} + 1)/0.015$		mA
I_{CH}	High Clamp Current	$V_{CC1} + 4 > V_{IN} \geq V_{CC1} + 1$	$25 + (V_{IN} - V_{CC1} - 1)/0.015$		mA
$slew_R$	Output Rise Slew Rate	$0.2V_{CC1}$ to $0.6V_{CC1}$ load ³	1	4	V/ns
$slew_F$	Output Fall Slew Rate	$0.6V_{CC1}$ to $0.2V_{CC1}$ load ³	1	4	V/ns

Notes:

1. Refer to the V-I curves in Figure 1-13 on page 1-14. Switching current characteristics for REQ# and GNT# are permitted to be one-half of that specified here; i.e., half-size output drivers may be used on these signals. This specification does not apply to CLK and RST#, which are system outputs. "Switching Current High" specifications are not relevant to SERR#, INTA#, INTB#, INTC#, or INTD#, which are open drain outputs.
2. Maximum current requirements must be met as drivers pull beyond the last step voltage. EQ 1-3 and EQ 1-4 define these maxima. The equation-defined maximum should be met by the design. To facilitate component testing, a maximum current test point is defined for each side of the output driver.
3. This parameter is to be interpreted as the cumulative edge rate across the specified range, rather than the instantaneous rate at any point within the transition range. The specified load (Figure 1-14) is optional; i.e., the designer may elect to meet this parameter with an unloaded output per the latest revision of the PCI Local Bus Specification. However, adherence to both maximum and minimum parameters is required (the maximum is no longer simply a guideline). Rise slew rate does not apply to open drain outputs.

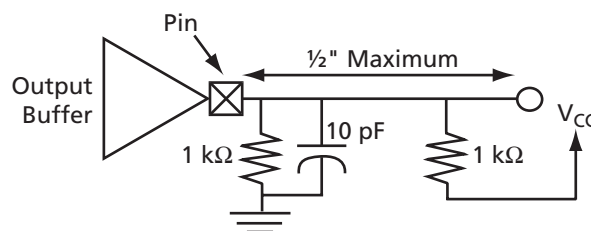

Figure 1-14 • 3.3 V PCI Slew Load

$$I_{OH} = (98.0/V_{CC1}) * (V_{OUT} - V_{CC1}) * (V_{OUT} + 0.4V_{CC1})$$

for $V_{CC1} > V_{OUT} > 0.7V_{CC1}$

EQ 1-3

$$I_{OL} = (256/V_{CC1}) * V_{OUT} * (V_{CC1} - V_{OUT})$$

for $0 < V_{OUT} < 0.18V_{CC1}$

EQ 1-4

Junction Temperature (T_j)

The temperature variable selected in the Designer software refers to the junction temperature, not the ambient temperature. This is an important distinction because the heat generated by dynamic power consumption usually produces a temperature hotter than the ambient temperature. EQ 1-5 can be used to calculate junction temperature.

$$\text{Junction Temperature} = \Delta T + T_a$$

EQ 1-5

where

T_a = Ambient temperature

ΔT = Temperature gradient between junction (silicon) and ambient

$$\Delta T = \theta_{ja} * P$$

EQ 1-6

where

P = Power

θ_{ja} = Junction-to-ambient thermal resistance of package. θ_{ja} values are given in Table 1-14.

Package Thermal Characteristics

The device junction-to-case thermal characteristic is θ_{jc}, and the junction-to-ambient characteristic is θ_{ja}. In Table 1-14, the values of θ_{ja} are given for two different air flow rates.

Table 1-14 • Sample Thermal Characteristics

Package Type	Pin Count	θ _{jc}	θ _{ja} Still Air	θ _{ja} 300 ft/min	Units
Ceramic Quad Flat Pack (CQFP)	84	–	–	–	°C/W
Ceramic Quad Flat Pack (CQFP)	208	6.3	22	14	°C/W
Ceramic Quad Flat Pack (CQFP)	256	6.2	20	10	°C/W

The maximum junction temperature is 150°C.

A sample calculation of the absolute maximum power dissipation allowed for a 256-pin CQFP package at commercial temperatures and in still air is given in EQ .

$$\text{Maximum Power Allowed} = \frac{\text{Max. junction temp. (°C)} - \text{Max. ambient temp. (°C)}}{\theta_{ja}(\text{°C/W})} = \frac{150\text{°C} - 70\text{°C}}{20\text{°C/W}} = 4.0 \text{ W}$$

EQ 1-7

For Device Power Calculator information, see the [Software Tools](#) section on the Actel website.

HiRel SX-A Timing Model

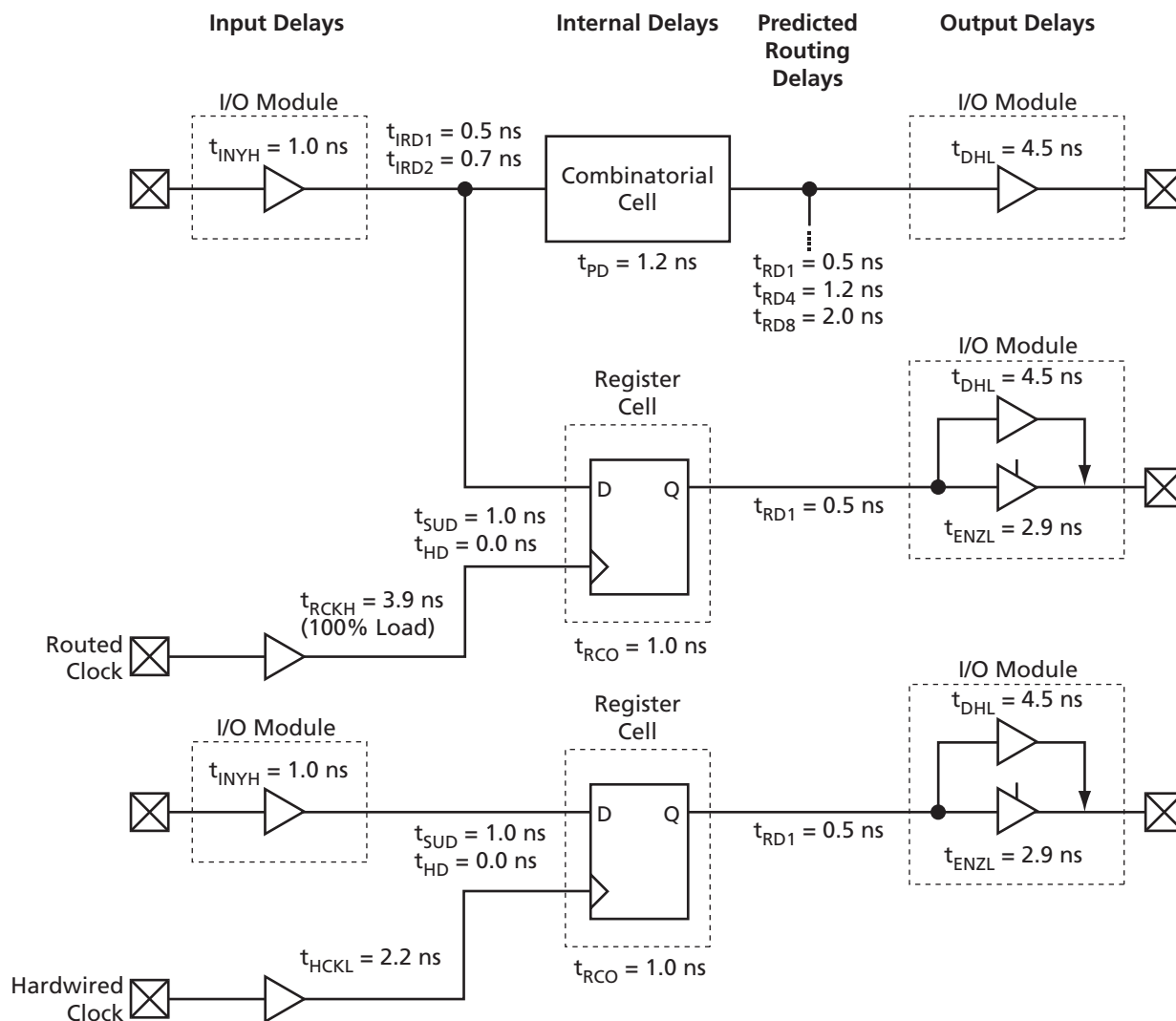

Note: *Values shown for are HiRel A54SX72A-1, worst-case military conditions for $V_{CC1} = 3.0 \text{ V}$.

Figure 1-15 • HiRel SX-A Timing Model

Hardwired Clock

External Setup

$$\begin{aligned}
 &= t_{INYH} + t_{RD1} + t_{SUD} - t_{HCKL} \\
 &= 1.0 + 0.5 + 1.0 - 2.2 = 0.3 \text{ ns}
 \end{aligned}$$

EQ 1-8

Clock-to-Out (Pin-to-Pin)

$$\begin{aligned}
 &= t_{HCKL} + t_{RCO} + t_{RD1} + t_{DHL} \\
 &= 2.2 + 1.0 + 0.5 + 4.5 = 8.2 \text{ ns}
 \end{aligned}$$

EQ 1-9

Routed Clock

External Setup

$$\begin{aligned}
 &= t_{INYH} + t_{RD1} + t_{SUD} - t_{RCKH} \\
 &= 1.0 + 0.5 + 1.0 - 3.9 = -1.4 \text{ ns}
 \end{aligned}$$

EQ 1-10

Clock-to-Out (Pin-to-Pin)

$$\begin{aligned}
 &= t_{RCKH} + t_{RCO} + t_{RD1} + t_{DHL} \\
 &= 3.9 + 1.0 + 0.5 + 4.5 = 9.9 \text{ ns}
 \end{aligned}$$

EQ 1-11

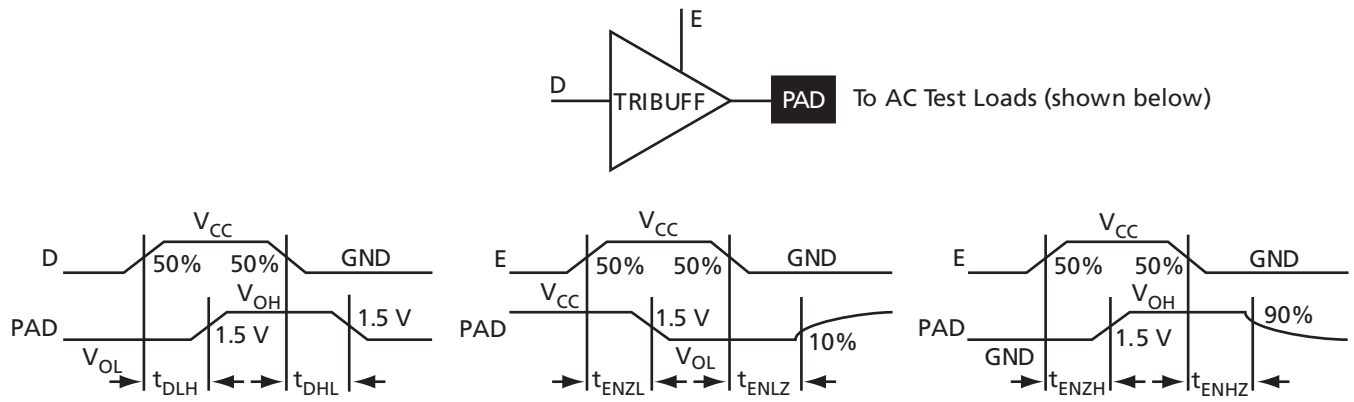

Figure 1-16 • Output Buffer Delays

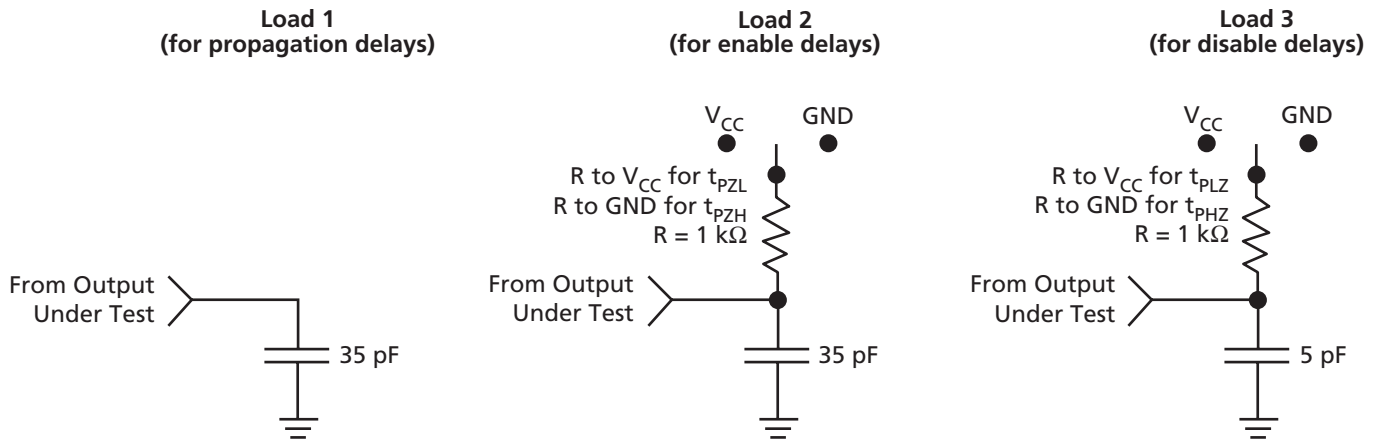

Figure 1-17 • AC Test Loads

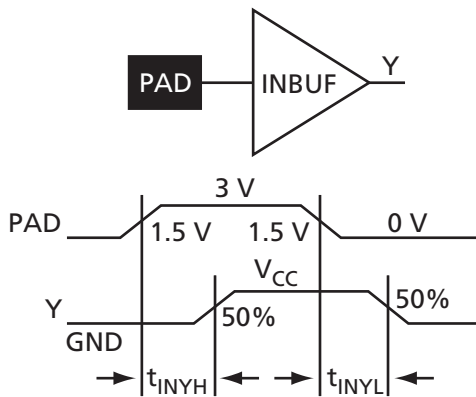

Figure 1-18 • Input Buffer Delays

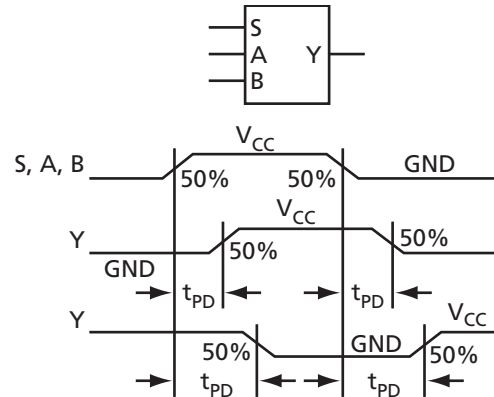
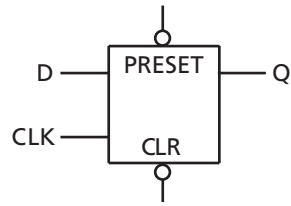

Figure 1-19 • C-Cell Delays



(Positive Edge Triggered)

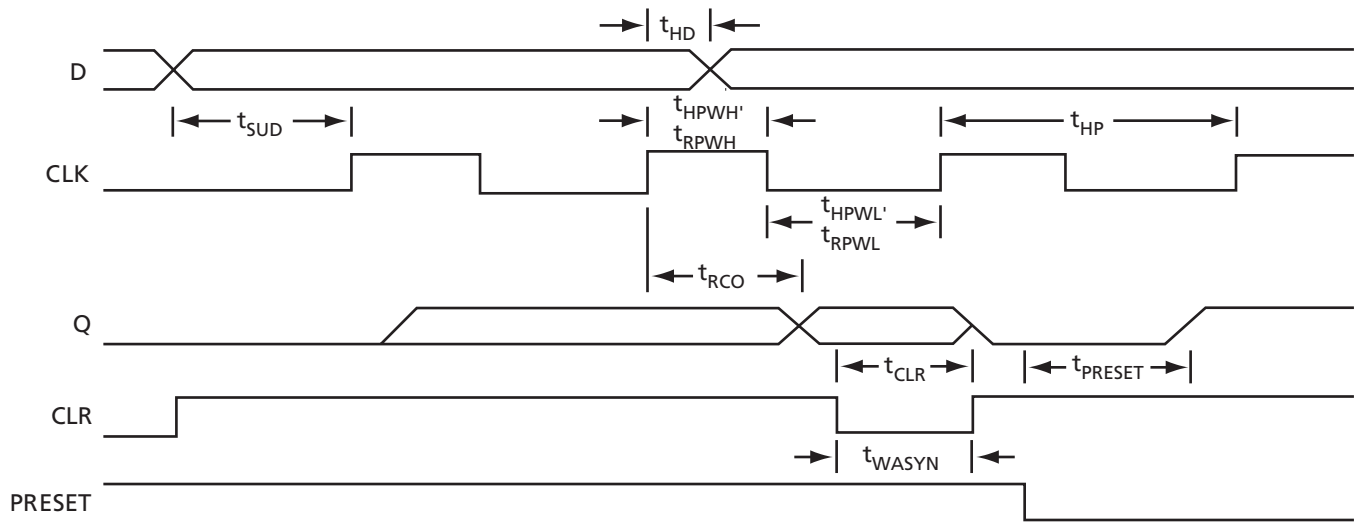

Figure 1-20 • Cell Timing Characteristics

Timing Characteristics

Timing characteristics for HiRel SX-A devices fall into three categories: family-dependent, device-dependent, and design-dependent. The input and output buffer characteristics are common to all HiRel SX-A family members. Internal routing delays are device-dependent. Design dependency means actual delays are not determined until after place-and-route of the user's design is complete. Delay values may then be determined by using the Timer utility or performing simulation with post-layout delays.

Critical Nets and Typical Nets

Propagation delays are expressed only for typical nets, which are used for initial design performance evaluation. Critical net delays can then be applied to the most timing-critical paths. Critical nets are determined by net property assignment prior to place-and-route. Up to six percent of the nets in a design may be designated as critical, whereas 90 percent of the nets in a design are typical.

Long Tracks

Some nets in the design use long tracks. Long tracks are special routing resources that span multiple rows, columns, or modules. Long tracks employ three to five antifuse connections. This increases capacitance and resistance, resulting in longer net delays for macros connected to long tracks. Typically, up to six percent of nets in a fully utilized device require long tracks. Long tracks contribute approximately 4 to 8.4 ns of delay. This additional delay is represented statistically in higher-fanout (FO = 24) routing delays. See [Table 1-16](#) on page 1-21 to [Table 1-25](#) on page 1-30.

Timing Derating

HiRel SX-A devices are manufactured with a CMOS process. Therefore, device performance varies according to temperature, voltage, and process changes. Minimum timing parameters reflect maximum operating voltage, minimum operating temperature, and best-case process characteristics. Maximum timing parameters reflect minimum operating voltage, maximum operating temperature, and worst-case processing.

Table 1-15 • Temperature and Voltage Derating Factors
Normalized to Worst-Case Military, $T_J = 125^\circ\text{C}$, $V_{CCA} = 2.25\text{ V}$

V _{CC}	Junction Temperature (T _J)						
	-55°C	-40°C	0°C	25°C	70°C	85°C	125°C
2.25	0.73	0.74	0.80	0.82	0.90	0.93	1.00
2.50	0.68	0.69	0.75	0.76	0.84	0.87	0.94
2.75	0.63	0.64	0.70	0.71	0.78	0.81	0.87

Table 1-16 • HiRel A54SX32A Timing Characteristics
 Worst-Case Military Conditions, $V_{CCA} = 2.25\text{ V}$, $V_{CCI} = 3.0\text{ V}$, $T_J = 125^\circ\text{C}$

Parameter	Description	'-1' Speed		'Std' Speed		Units
		Min.	Max.	Min.	Max.	
C-Cell Propagation Delays¹						
t_{PD}	Internal Array Module		1.2		1.4	ns
Predicted Routing Delays²						
t_{DC}	FO = 1 Routing Delay, DirectConnect		0.1		0.1	ns
t_{FC}	FO = 1 Routing Delay, FastConnect		0.2		0.2	ns
t_{RD1}	FO = 1 Routing Delay		0.5		0.6	ns
t_{RD2}	FO = 2 Routing Delay		0.7		0.8	ns
t_{RD3}	FO = 3 Routing Delay		0.9		1	ns
t_{RD4}	FO = 4 Routing Delay		1.2		1.3	ns
t_{RD8}	FO = 8 Routing Delay		2		2.4	ns
t_{RD12}	FO = 12 Routing Delay		2.9		3.5	ns
R-Cell Timing						
t_{RCO}	Sequential Clock to Q		0.9		1.1	ns
t_{CLR}	Asynchronous Clear to Q		0.7		0.8	ns
t_{PRESET}	Asynchronous Preset to Q		0.8		0.9	ns
t_{SUD}	Flip-Flop Data Input Setup	0.8		1.0		ns
t_{HD}	Flip-Flop Data Input Hold	0.0		0.0		ns
t_{WASYN}	Asynchronous Pulse Width	1.7		2.0		ns
$t_{RECASYN}$	Asynchronous Recovery		0.7		0.9	ns
t_{HASYN}	Asynchronous Hold Time		0.7		0.9	ns
t_{MPW}	Clock Pulse Width	2.0		2.3		ns
Input Module Propagation Delays						
t_{INYH}	Input Data Pad to Y HIGH 3.3 V PCI		0.8		0.9	ns
t_{INYL}	Input Data Pad to Y LOW 3.3 V PCI		0.8		1.0	ns
t_{INYH}	Input Data Pad to Y HIGH 3.3 V LVTTTL		2.3		2.7	ns
t_{INYL}	Input Data Pad to Y LOW 3.3 V LVTTTL		1.1		1.3	ns
t_{INYH}	Input Data Pad to Y HIGH 5 V PCI		1.1		1.2	ns
t_{INYL}	Input Data Pad to Y LOW 5 V PCI		1.3		1.5	ns
t_{INYH}	Input Data Pad to Y HIGH 5 V TTL		2.2		2.6	ns
t_{INYL}	Input Data Pad to Y LOW 5 V TTL		1.3		1.5	ns
Input Module Predicted Routing Delays²						
t_{IRD1}	FO=1 Routing Delay		0.5		0.6	ns
t_{IRD2}	FO=2 Routing Delay		0.7		0.8	ns
t_{IRD3}	FO=3 Routing Delay		0.9		1	ns
t_{IRD4}	FO=4 Routing Delay		1.2		1.3	ns
t_{IRD8}	FO=8 Routing Delay		2		2.4	ns
t_{IRD12}	FO=12 Routing Delay		2.9		3.5	ns

Notes:

1. For dual-module macros, use $t_{PD} + t_{RD1} + t_{PDn}$, $t_{RCO} + t_{RD1} + t_{PDn}$, or $t_{PD1} + t_{RD1} + t_{SUD}$, whichever is appropriate.
2. Routing delays are for typical designs under worst-case operating conditions. These parameters should be used for estimating device performance. Post-route timing analysis or simulation is required to determine actual performance.

Table 1-17 • HiRel A54SX32A Timing Characteristics
 Worst-Case Military Conditions, $V_{CCA} = 2.25\text{ V}$, $V_{CCI} = 3.0\text{ V}$, $T_J = 125^\circ\text{C}$

Parameter	Description	'-1' Speed		'Std' Speed		Units
		Min.	Max.	Min.	Max.	
Dedicated (hardwired) Array Clock Network						
t_{HCKH}	Input Low to High (pad to R-Cell input)		2.5		3.0	ns
t_{HCKL}	Input High to Low (pad to R-Cell input)		2.3		2.7	ns
t_{HPWH}	Minimum Pulse Width High	2.0		2.3		ns
t_{HPWL}	Minimum Pulse Width Low	2.0		2.3		ns
t_{HCKSW}	Maximum Skew		1.3		1.5	ns
t_{HP}	Minimum Period	4.0		4.6		ns
f_{HMAX}	Maximum Frequency		250		217	MHz
Routed Array Clock Networks						
t_{RCKH}	Input Low to High (pad to R-Cell input, light load)		3.3		3.8	ns
t_{RCKL}	Input High to Low (pad to R-Cell input, light load)		2.9		3.4	ns
t_{RCKH}	Input Low to High (pad to R-Cell input, 50% load)		3.5		4.2	ns
t_{RCKL}	Input High to Low (pad to R-Cell input, 50% load)		3.0		3.5	ns
t_{RCKH}	Input Low to High (pad to R-Cell input, 100% load)		3.7		4.3	ns
t_{RCKL}	Input High to Low (pad to R-Cell input, 100% load)		3.2		3.8	ns
t_{RPWH}	Minimum Pulse Width High	2.0		2.3		ns
t_{RPWL}	Minimum Pulse Width Low	2.0		2.3		ns
t_{RCKSW}	Maximum Skew (light load)		2.5		2.9	ns
t_{RCKSW}	Maximum Skew (50% load)		2.7		3.2	ns
t_{RCKSW}	Maximum Skew (100% load)		2.7		3.2	ns

Notes:

1. For dual-module macros, use $t_{PD} + t_{RD1} + t_{PDn}$, $t_{RCO} + t_{RD1} + t_{PDn}$, or $t_{PD1} + t_{RD1} + t_{SUD}$, whichever is appropriate.
2. Routing delays are for typical designs under worst-case operating conditions. These parameters should be used for estimating device performance. Post-route timing analysis or simulation is required to determine actual performance.

Table 1-18 • HiRel A54SX32A Timing Characteristics
 Worst-Case Military Conditions, $V_{CCA} = 2.25\text{ V}$, $V_{CCI} = 4.75\text{ V}$, $T_J = 125^\circ\text{C}$

Parameter	Description	'-1' Speed		'Std' Speed		Units
		Min.	Max.	Min.	Max.	
Dedicated (hardwired) Array Clock Network						
t_{HCKH}	Input Low to High (pad to R-Cell input)		2.5		3.0	ns
t_{HCKL}	Input High to Low (pad to R-Cell input)		2.3		2.7	ns
t_{HPWH}	Minimum Pulse Width High	2.0		2.3		ns
t_{HPWL}	Minimum Pulse Width Low	2.0		2.3		ns
t_{HCKSW}	Maximum Skew		1.4		1.7	ns
t_{HP}	Minimum Period	4.0		4.6		ns
f_{HMAX}	Maximum Frequency		250		217	MHz
Routed Array Clock Networks						
t_{RCKH}	Input Low to High (pad to R-Cell input, light load)		3.4		3.9	ns
t_{RCKL}	Input High to Low (pad to R-Cell input, light load)		2.9		3.4	ns
t_{RCKH}	Input Low to High (pad to R-Cell input, 50% load)		3.6		4.3	ns
t_{RCKL}	Input High to Low (pad to R-Cell input, 50% load)		3.1		3.6	ns
t_{RCKH}	Input Low to High (pad to R-Cell input, 100% load)		3.8		4.4	ns
t_{RCKL}	Input High to Low (pad to R-Cell input, 100% load)		3.3		3.9	ns
t_{RPWH}	Minimum Pulse Width High	2.0		2.3		ns
t_{RPWL}	Minimum Pulse Width Low	2.0		2.3		ns
t_{RCKSW}	Maximum Skew (light load)		2.5		3.0	ns
t_{RCKSW}	Maximum Skew (50% load)		2.7		3.2	ns
t_{RCKSW}	Maximum Skew (100% load)		2.8		3.3	ns

Notes:

1. For dual-module macros, use $t_{PD} + t_{RD1} + t_{PDn}$, $t_{RCO} + t_{RD1} + t_{PDn}$, or $t_{PD1} + t_{RD1} + t_{SUD}$, whichever is appropriate.
2. Routing delays are for typical designs under worst-case operating conditions. These parameters should be used for estimating device performance. Post-route timing analysis or simulation is required to determine actual performance.

Table 1-19 • A54SX32A Timing Characteristics
(Worst-Case Military Conditions $V_{CCA} = 2.25\text{ V}$, $V_{CCI} = 3.0\text{ V}$, $T_J = 125^\circ\text{C}$)

Parameter	Description	-1 Speed		Std. Speed		Units
		Min.	Max.	Min.	Max.	
3.3 V PCI Output Module Timing¹						
t_{DLH}	Data-to-Pad Low to High		3.1		3.6	ns
t_{DHL}	Data-to-Pad High to Low		3.6		4.2	ns
t_{ENZL}	Enable-to-Pad, Z to L		2.0		2.3	ns
t_{ENZH}	Enable-to-Pad, Z to H		3.1		3.6	ns
t_{ENLZ}	Enable-to-Pad, L to Z		3.8		4.5	ns
t_{ENHZ}	Enable-to-Pad, H to Z		2.8		3.3	ns
d_{TLH}^2	Delta Low to High		0.02		0.04	ns/pF
d_{THL}^2	Delta High to Low		0.05		0.05	ns/pF
3.3 V LVTTL Output Module Timing³						
t_{DLH}	Data-to-Pad Low to High		4.3		5.1	ns
t_{DHL}	Data-to-Pad High to Low		3.6		4.2	ns
t_{ENZL}	Enable-to-Pad, Z to L		3.9		4.6	ns
t_{ENZH}	Enable-to-Pad, Z to H		4.3		5.1	ns
t_{ENLZ}	Enable-to-Pad, L to Z		4.2		4.9	ns
t_{ENHZ}	Enable-to-Pad, H to Z		3.6		4.2	ns
d_{TLH}^2	Delta Low to High		0.02		0.04	ns/pF
d_{THL}^2	Delta High to Low		0.05		0.05	ns/pF

Notes:

- Delays based on 10 pF loading and 25 Ω resistance.
- To obtain the slew rate, substitute the appropriate Delta value, load capacitance, and the V_{CCI} value into the following equation:

$$\text{Slew Rate [V/ns]} = (0.1 * V_{CCI} - 0.9 * V_{CCI}) / (C_{load} * d_{T[LH|HL|HLS]})$$
 where C_{load} is the load capacitance driven by the I/O in pF
 $d_{T[LH|HL|HLS]}$ is the worst case delta value from the datasheet in ns/pF.
- Delays based on 35 pF loading.

Table 1-20 • A54SX32A Timing Characteristics
 (Worst-Case Military Conditions $V_{CCA} = 2.25\text{ V}$, $V_{CCI} = 4.75\text{ V}$, $T_J = 125^\circ\text{C}$)

Parameter	Description	-1 Speed		Std. Speed		Units
		Min.	Max.	Min.	Max.	
5.0 V PCI Output Module Timing¹						
t_{DLH}	Data-to-Pad Low to High		3.6		4.2	ns
t_{DHL}	Data-to-Pad High to Low		3.7		4.4	ns
t_{ENZL}	Enable-to-Pad, Z to L		2.0		2.3	ns
t_{ENZH}	Enable-to-Pad, Z to H		3.6		4.2	ns
t_{ENLZ}	Enable-to-Pad, L to Z		4.1		4.8	ns
t_{ENHZ}	Enable-to-Pad, H to Z		3.7		4.4	ns
d_{TLH}^2	Delta Low to High		0.02		0.04	ns/pF
d_{THL}^2	Delta High to Low		0.05		0.05	ns/pF
5.0 V LVTTL Output Module Timing³						
t_{DLH}	Data-to-Pad Low to High		3.2		3.8	ns
t_{DHL}	Data-to-Pad High to Low		3.4		4.0	ns
t_{ENZL}	Enable-to-Pad, Z to L		3.9		4.6	ns
t_{ENZH}	Enable-to-Pad, Z to H		3.2		3.8	ns
t_{ENLZ}	Enable-to-Pad, L to Z		5.1		6.0	ns
t_{ENHZ}	Enable-to-Pad, H to Z		3.4		4.0	ns
d_{TLH}^2	Delta Low to High		0.02		0.04	ns/pF
d_{THL}^2	Delta High to Low		0.05		0.05	ns/pF

Notes:

- Delays based on 10 pF loading and 25 Ω resistance.
- To obtain the slew rate, substitute the appropriate Delta value, load capacitance, and the V_{CCI} value into the following equation:

$$\text{Slew Rate [V/ns]} = (0.1 * V_{CCI} - 0.9 * V_{CCI}) / (C_{load} * d_{T[LH|HL|HLS]})$$
 where C_{load} is the load capacitance driven by the I/O in pF
 $d_{T[LH|HL|HLS]}$ is the worst case delta value from the datasheet in ns/pF.
- Delays based on 35 pF loading.

Table 1-21 • HiRel A54SX72A Timing Characteristics
 Worst-Case Military Conditions, $V_{CCA} = 2.25\text{ V}$, $V_{CCI} = 3.0\text{ V}$, $T_J = 125^\circ\text{C}$

Parameter	Description	'-1' Speed		'Std' Speed		Units
		Min.	Max.	Min.	Max.	
C-Cell Propagation Delays¹						
t_{PD}	Internal Array Module		1.2		1.4	ns
Predicted Routing Delays²						
t_{DC}	FO = 1 Routing Delay, DirectConnect		0.1		0.1	ns
t_{FC}	FO = 1 Routing Delay, FastConnect		0.2		0.2	ns
t_{RD1}	FO = 1 Routing Delay		0.5		0.6	ns
t_{RD2}	FO = 2 Routing Delay		0.7		0.8	ns
t_{RD3}	FO = 3 Routing Delay		0.9		1	ns
t_{RD4}	FO = 4 Routing Delay		1.2		1.3	ns
t_{RD8}	FO = 8 Routing Delay		2		2.4	ns
t_{RD12}	FO = 12 Routing Delay		2.9		3.5	ns
R-Cell Timing						
t_{RCO}	Sequential Clock to Q		1.0		1.2	ns
t_{CLR}	Asynchronous Clear to Q		0.8		0.9	ns
t_{PRESET}	Asynchronous Preset to Q		0.9		1.1	ns
t_{SUD}	Flip-Flop Data Input Setup	1.0		1.1		ns
t_{HD}	Flip-Flop Data Input Hold	0.0		0.0		ns
t_{WASYN}	Asynchronous Pulse Width	1.9		2.2		ns
$t_{RECA SYN}$	Asynchronous Recovery		0.8		1.0	ns
t_{HASYN}	Asynchronous Hold Time		0.8		1.0	ns
t_{MPW}	Clock Pulse Width	2.2		2.6		ns
Input Module Propagation Delays						
t_{INYH}	Input Data Pad to Y HIGH 3.3 V PCI		0.9		1.1	ns
t_{INYL}	Input Data Pad to Y LOW 3.3 V PCI		1.0		1.1	ns
t_{INYH}	Input Data Pad to Y HIGH 3.3 V LVTTTL		1.0		1.2	ns
t_{INYL}	Input Data Pad to Y LOW 3.3 V LVTTTL		1.4		1.7	ns
t_{INYH}	Input Data Pad to Y HIGH 5 V PCI		0.8		1.0	ns
t_{INYL}	Input Data Pad to Y LOW 5 V PCI		1.1		1.2	ns
t_{INYH}	Input Data Pad to Y HIGH 5 V TTL		1.1		1.2	ns
t_{INYL}	Input Data Pad to Y LOW 5 V TTL		1.1		1.3	ns
Input Module Predicted Routing Delays²						
t_{IRD1}	FO=1 Routing Delay		0.5		0.6	ns
t_{IRD2}	FO=2 Routing Delay		0.7		0.8	ns
t_{IRD3}	FO=3 Routing Delay		0.9		1	ns
t_{IRD4}	FO=4 Routing Delay		1.2		1.3	ns
t_{IRD8}	FO=8 Routing Delay		2		2.4	ns
t_{IRD12}	FO=12 Routing Delay		2.9		3.5	ns

Notes:

1. For dual-module macros, use $t_{PD} + t_{RD1} + t_{PDn}$, $t_{RCO} + t_{RD1} + t_{PDn}$, or $t_{PD1} + t_{RD1} + t_{SUD}$, whichever is appropriate.
2. Routing delays are for typical designs under worst-case operating conditions. These parameters should be used for estimating device performance. Post-route timing analysis or simulation is required to determine actual performance.

Table 1-22 • HiRel A54SX72A Timing Characteristics
 Worst-Case Military Conditions, $V_{CCA} = 2.25\text{ V}$, $V_{CCI} = 3.0\text{ V}$, $T_J = 125^\circ\text{C}$

Parameter	Description	'-1' Speed		'Std' Speed		Units
		Min.	Max.	Min.	Max.	
Dedicated (hardwired) Array Clock Network						
t_{HCKH}	Input Low to High (pad to R-Cell input)		2.4		2.8	ns
t_{HCKL}	Input High to Low (pad to R-Cell input)		2.2		2.6	ns
t_{HPWH}	Minimum Pulse Width High	2.2		2.6		ns
t_{HPWL}	Minimum Pulse Width Low	2.2		2.6		ns
t_{HCKSW}	Maximum Skew		2		2.4	ns
t_{HP}	Minimum Period	4.4		5.2		ns
f_{HMAX}	Maximum Frequency		227		192	MHz
Routed Array Clock Networks						
t_{RCKH}	Input Low to High (pad to R-Cell input, light load)		3.3		3.9	ns
t_{RCKL}	Input High to Low (pad to R-Cell input, light load)		3.8		4.5	ns
t_{RCKH}	Input Low to High (pad to R-Cell input, 50% load)		3.6		4.2	ns
t_{RCKL}	Input High to Low (pad to R-Cell input, 50% load)		3.9		4.6	ns
t_{RCKH}	Input Low to High (pad to R-Cell input, 100% load)		3.9		4.6	ns
t_{RCKL}	Input High to Low (pad to R-Cell input, 100% load)		4.2		4.9	ns
t_{RPWH}	Minimum Pulse Width High	2.2		2.6		ns
t_{RPWL}	Minimum Pulse Width Low	2.2		2.6		ns
t_{RCKSW}	Maximum Skew (light load)		3.3		3.9	ns
t_{RCKSW}	Maximum Skew (50% load)		3.4		3.9	ns
t_{RCKSW}	Maximum Skew (100% load)		3.5		4.1	ns
Quadrant Array Clock Networks						
t_{QCKH}	Input Low to High (Light Load) (Pad to R-cell Input)		2.0		2.3	ns
t_{QCKL}	Input High to Low (Light Load) (Pad to R-cell Input)		1.8		2.1	ns
t_{QCKH}	Input Low to High (50% Load) (Pad to R-cell Input)		2.3		2.7	ns
t_{QCKL}	Input High to Low (50% Load) (Pad to R-cell Input)		2.1		2.4	ns
t_{QCKH}	Input Low to High (100% Load) (Pad to R-cell Input)		2.6		3.0	ns
t_{QCKL}	Input High to Low (100% Load) (Pad to R-cell Input)		2.3		2.7	ns
t_{QPWH}	Minimum Pulse Width High	2.2		2.6		ns
t_{QPWL}	Minimum Pulse Width Low	2.2		2.6		ns
t_{QCKSW}	Maximum Skew (Light Load)		1.5		1.8	ns
t_{QCKSW}	Maximum Skew (50% Load)		1.7		2	ns
t_{QCKSW}	Maximum Skew (100% Load)		1.9		2.2	ns

Notes:

1. For dual-module macros, use $t_{PD} + t_{RD1} + t_{PDn}$, $t_{RCO} + t_{RD1} + t_{PDn}$, or $t_{PD1} + t_{RD1} + t_{SUD}$, whichever is appropriate.
2. Routing delays are for typical designs under worst-case operating conditions. These parameters should be used for estimating device performance. Post-route timing analysis or simulation is required to determine actual performance.

HiRel SX-A Family FPGAs

Table 1-23 • HiRel A54SX72A Timing Characteristics
Worst-Case Military Conditions, $V_{CCA} = 2.25\text{ V}$, $V_{CCI} = 4.75\text{ V}$, $T_J = 125^\circ\text{C}$

Parameter	Description	'-1' Speed		'Std' Speed		Units
		Min.	Max.	Min.	Max.	
Dedicated (hardwired) Array Clock Network						
t_{HCKH}	Input Low to High (pad to R-Cell input)		2.4		2.8	ns
t_{HCKL}	Input High to Low (pad to R-Cell input)		2.2		2.6	ns
t_{HPWH}	Minimum Pulse Width High	2.2		2.6		ns
t_{HPWL}	Minimum Pulse Width Low	2.2		2.6		ns
t_{HCKSW}	Maximum Skew		2.1		2.4	ns
t_{HP}	Minimum Period	4.4		5.2		ns
f_{HMAX}	Maximum Frequency		227		192	MHz
Routed Array Clock Networks						
t_{RCKH}	Input Low to High (pad to R-Cell input, light load)		3.5		4.1	ns
t_{RCKL}	Input High to Low (pad to R-Cell input, light load)		3.8		4.5	ns
t_{RCKH}	Input Low to High (pad to R-Cell input, 50% load)		3.7		4.4	ns
t_{RCKL}	Input High to Low (pad to R-Cell input, 50% load)		4.1		4.8	ns
t_{RCKH}	Input Low to High (pad to R-Cell input, 100% load)		3.9		4.6	ns
t_{RCKL}	Input High to Low (pad to R-Cell input, 100% load)		4.3		5.1	ns
t_{RPWH}	Minimum Pulse Width High	2.2		2.6		ns
t_{RPWL}	Minimum Pulse Width Low	2.2		2.6		ns
t_{RCKSW}	Maximum Skew (light load)		3.3		3.9	ns
t_{RCKSW}	Maximum Skew (50% load)		3.4		4.0	ns
t_{RCKSW}	Maximum Skew (100% load)		3.6		4.2	ns
Quadrant Array Clock Networks						
t_{QCKH}	Input Low to High (Light Load) (Pad to R-cell Input)		1.9		2.2	ns
t_{QCHKL}	Input High to Low (Light Load) (Pad to R-cell Input)		1.7		2.0	ns
t_{QCKH}	Input Low to High (50% Load) (Pad to R-cell Input)		2.2		2.6	ns
t_{QCHKL}	Input High to Low (50% Load) (Pad to R-cell Input)		2.0		2.3	ns
t_{QCKH}	Input Low to High (100% Load) (Pad to R-cell Input)		2.5		2.9	ns
t_{QCHKL}	Input High to Low (100% Load) (Pad to R-cell Input)		2.3		2.6	ns
t_{QPWH}	Minimum Pulse Width High	2.2		2.6		ns
t_{QPWL}	Minimum Pulse Width Low	2.2		2.6		ns
t_{QCKSW}	Maximum Skew (Light Load)		1.3		1.5	ns
t_{QCKSW}	Maximum Skew (50% Load)		1.5		1.8	ns
t_{QCKSW}	Maximum Skew (100% Load)		1.7		2.0	ns

Notes:

1. For dual-module macros, use $t_{PD} + t_{RD1} + t_{PDn}$, $t_{RCO} + t_{RD1} + t_{PDn}$, or $t_{PD1} + t_{RD1} + t_{SUD}$, whichever is appropriate.
2. Routing delays are for typical designs under worst-case operating conditions. These parameters should be used for estimating device performance. Post-route timing analysis or simulation is required to determine actual performance.

Table 1-24 • A54SX72A Timing Characteristics
 (Worst-Case Military Conditions $V_{CCA} = 2.25\text{ V}$, $V_{CCI} = 3.0\text{ V}$, $T_J = 125^\circ\text{C}$)

Parameter	Description	-1 Speed		Std. Speed		Units
		Min.	Max.	Min.	Max.	
3.3 V PCI Output Module Timing¹						
t_{DLH}	Data-to-Pad Low to High		3.5		4.1	ns
t_{DHL}	Data-to-Pad High to Low		3.8		4.5	ns
t_{ENZL}	Enable-to-Pad, Z to L		1.9		2.2	ns
t_{ENZH}	Enable-to-Pad, Z to H		3.5		4.1	ns
t_{ENLZ}	Enable-to-Pad, L to Z		3.2		3.8	ns
t_{ENHZ}	Enable-to-Pad, H to Z		3.8		4.5	ns
d_{TLH}^2	Delta Low to High		0.02		0.04	ns/pF
d_{THL}^2	Delta High to Low		0.05		0.05	ns/pF
3.3 V LVTTL Output Module Timing³						
t_{DLH}	Data-to-Pad Low to High		5.1		5.9	ns
t_{DHL}	Data-to-Pad High to Low		4.5		5.3	ns
t_{ENZL}	Enable-to-Pad, Z to L		2.9		3.4	ns
t_{ENZH}	Enable-to-Pad, Z to H		5.1		5.9	ns
t_{ENLZ}	Enable-to-Pad, L to Z		3.7		4.4	ns
t_{ENHZ}	Enable-to-Pad, H to Z		4.5		5.3	ns
d_{TLH}^2	Delta Low to High		0.02		0.04	ns/pF
d_{THL}^2	Delta High to Low		0.05		0.05	ns/pF

Notes:

- Delays based on 10 pF loading and 25 Ω resistance.
- To obtain the slew rate, substitute the appropriate Delta value, load capacitance, and the V_{CCI} value into the following equation:

$$\text{Slew Rate [V/ns]} = (0.1 * V_{CCI} - 0.9 * V_{CCI}) / (C_{load} * d_{T[LH|HL|HLS]})$$
 where C_{load} is the load capacitance driven by the I/O in pF
 $d_{T[LH|HL|HLS]}$ is the worst case delta value from the datasheet in ns/pF.
- Delays based on 35 pF loading.

Table 1-25 • A54SX72A Timing Characteristics
(Worst-Case Military Conditions $V_{CCA} = 2.25\text{ V}$, $V_{CCI} = 4.75\text{ V}$, $T_J = 125^\circ\text{C}$)

Parameter	Description	-1 Speed		Std. Speed		Units
		Min.	Max.	Min.	Max.	
5.0 V PCI Output Module Timing¹						
t_{DLH}	Data-to-Pad Low to High		4.2		4.9	ns
t_{DHL}	Data-to-Pad High to Low		4.3		5.0	ns
t_{ENZL}	Enable-to-Pad, Z to L		1.7		2.0	ns
t_{ENZH}	Enable-to-Pad, Z to H		4.2		4.9	ns
t_{ENLZ}	Enable-to-Pad, L to Z		3.9		4.6	ns
t_{ENHZ}	Enable-to-Pad, H to Z		4.3		5.0	ns
d_{TLH}^2	Delta Low to High		0.02		0.04	ns/pF
d_{THL}^2	Delta High to Low		0.05		0.05	ns/pF
5.0 V LVTTL Output Module Timing³						
t_{DLH}	Data-to-Pad Low to High		3.9		4.6	ns
t_{DHL}	Data-to-Pad High to Low		4.2		4.9	ns
t_{ENZL}	Enable-to-Pad, Z to L		2.7		3.2	ns
t_{ENZH}	Enable-to-Pad, Z to H		3.9		4.6	ns
t_{ENLZ}	Enable-to-Pad, L to Z		4.7		5.6	ns
t_{ENHZ}	Enable-to-Pad, H to Z		4.2		4.9	ns
d_{TLH}^2	Delta Low to High		0.02		0.04	ns/pF
d_{THL}^2	Delta High to Low		0.05		0.05	ns/pF

Notes:

- Delays based on 10 pF loading and 25 Ω resistance.
- To obtain the slew rate, substitute the appropriate Delta value, load capacitance, and the V_{CCI} value into the following equation:

$$\text{Slew Rate [V/ns]} = (0.1 * V_{CCI} - 0.9 * V_{CCI}) / (C_{load} * d_{T[LH|HL|HLS]})$$
 where C_{load} is the load capacitance driven by the I/O in pF
 $d_{T[LH|HL|HLS]}$ is the worst case delta value from the datasheet in ns/pF.
- Delays based on 35 pF loading.

Pin Description

CLKA/B **Clock A/B**

These pins are clock inputs for clock distribution networks. Input levels are compatible with standard TTL, LVTTTL, 3.3 V PCI, or 5 V PCI specifications. The clock input is buffered prior to clocking the R-cells. If unused, these pins must be fixed LOW or HIGH on the board. They must not be left floating (for HiRel A54SX72A, these clocks can be configured as user I/O).

QCLKA/B/C/D, I/O **Quadrant Clock A/B/C/D, I/O**

These four pins are the clock inputs for the quadrant clock distribution networks and only exist on HiRel A54SX72A. Input levels are compatible with standard TTL, LVTTTL, 3.3 V PCI, or 5 V PCI specifications. Each of these clock inputs can drive up to a quarter of the chip, or they can be grouped together to drive multiple quadrants. The clock input is buffered prior to clocking the R-cells. If not used as a clock, each input will behave as a regular I/O.

GND **Ground**

LOW supply voltage.

HCLK **Dedicated (hardwired) Array Clock**

This pin is the clock input for sequential modules. Input levels are compatible with standard TTL, LVTTTL, 3.3 V PCI, or 5 V PCI specifications. This input is wired directly to each R-cell and offers clock speeds independent of the number of R-cells being driven. If not used, this pin must set LOW or HIGH on the board. It must not be left floating.

I/O **Input/Output**

The I/O pin functions as an input, output, tristate, or bidirectional buffer. Based on certain configurations, input and output levels are compatible with standard TTL, LVTTTL, 3.3 V PCI, or 5 V PCI specifications. Unused I/O pins are automatically tristated by the Designer software.

NC **No Connection**

This pin is not connected to circuitry within the device. These pins can be driven to any voltage or left floating with no effect on the operation of the device.

PRA/B, I/O¹ **Probe A/B**

The Probe pin is used to put out data from any user-defined design node within the device. This independent diagnostic pin can be used in conjunction with the other Probe pin to allow real-time diagnostic output of any signal path within the device. A Probe pin can be used as a user-defined I/O when verification has been completed. The pin's probe capabilities can be disabled permanently to protect programmed design confidentiality.

TCK, I/O¹ **Test Clock**

Test clock input for diagnostic probe and device programming. In Flexible mode, TCK becomes active when the TMS pin is set LOW (refer to [Table 1-5 on page 1-7](#)). This pin functions as an I/O when the boundary scan state machine reaches the "logic reset" state.

1. 70 Ω series termination should be placed on the board to enable probing capability.

TDI, I/O¹ Test Data Input

Serial input for boundary scan testing and diagnostic probe. In Flexible mode, TDI is active when the TMS pin is set LOW (Table 1-5 on page 1-7). This pin functions as an I/O when the boundary scan state machine reaches the "logic reset" state.

TDO, I/O¹ Test Data Output

Serial output for boundary scan testing. In Flexible mode, TDO is active when the TMS pin is set LOW (refer to Table 1-5 on page 1-7). This pin functions as an I/O when the boundary scan state machine reaches the "logic reset" state. When Silicon Explorer is being used, TDO acts as an output when the checksum command is run. It will return to a user I/O when the checksum is complete.

TMS¹ Test Mode Select

The TMS pin controls the use of the IEEE 1149.1 Boundary Scan pins (TCK, TDI, TDO, and TRST). In Flexible mode, when the TMS pin is set LOW, the TCK, TDI, and TDO pins are boundary scan pins (refer to Table 1-5 on page 1-7). Once the boundary scan pins are in test mode, they remain in that mode until the internal boundary scan state machine reaches the "logic reset" state. At this point, the boundary scan pins are released and will function as regular I/O pins. The "logic reset" state is reached five TCK cycles after the TMS pin is set HIGH. In dedicated test mode, TMS functions as specified in the IEEE 1149.1 specification.

TRST, I/O Boundary Scan Reset Pin

Once it is configured as the JTAG Reset pin, the TRST pin functions as an active low input that may be used to asynchronously initialize or reset the boundary scan circuitry. The TRST pin is equipped with an internal pull-up resistor. This pin functions as an I/O when the **Reserve JTAG Test Reset Pin** check box is cleared in the Actel Designer software.

V_{CCI} Supply Voltage

Supply voltage for I/Os. See Table 1-7 on page 1-10. All V_{CCI} power pins in the device should be connected.

V_{CCA} Supply Voltage

Supply voltage for array. See Table 1-7 on page 1-10. All V_{CCA} power pins in the device should be connected.

Package Pin Assignments

84-Pin CQFP

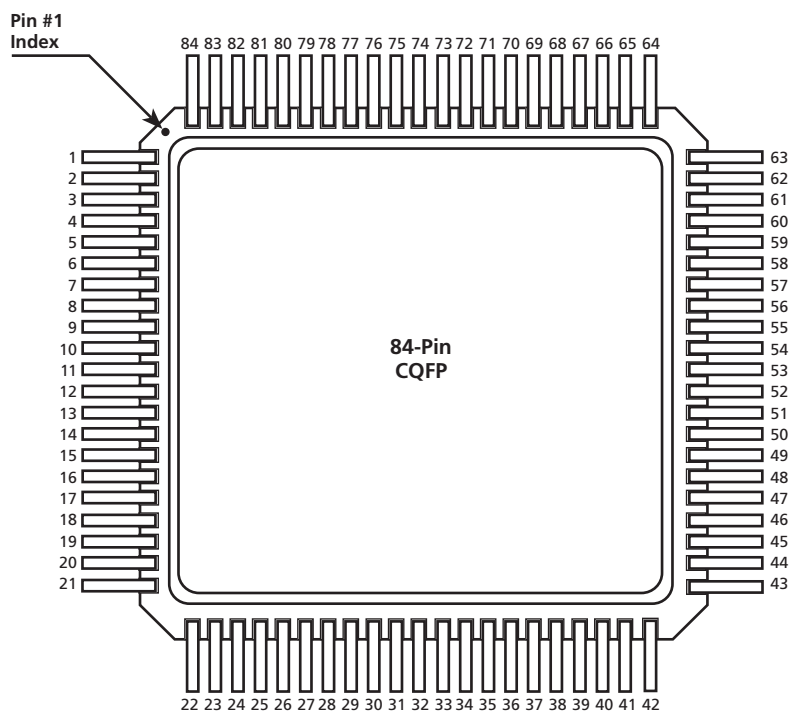

Figure 2-1 • 208-Pin CQFP (Top View)

Note

For Package Manufacturing and Environmental information, visit the Package Resource Center at www.actel.com/products/rescenter/package/index.html.

84-Pin CQFP	
Pin Number	HiRel A54SX32A Function
1	I/O
2	I/O
3	TMS
4	I/O
5	V _{CCI}
6	GND
7	I/O
8	I/O
9	I/O
10	I/O
11	TRST
12	I/O
13	I/O
14	I/O
15	V _{CCA}
16	GND
17	I/O
18	V _{CCA}
19	I/O
20	I/O
21	I/O
22	I/O
23	I/O
24	I/O
25	I/O
26	GND
27	V _{CCI}
28	I/O
29	I/O
30	I/O
31	I/O
32	PRB, I/O
33	HCLK
34	I/O
35	I/O

84-Pin CQFP	
Pin Number	HiRel A54SX32A Function
36	V _{CCA}
37	GND
38	I/O
39	TDO, I/O
40	I/O
41	I/O
42	I/O
43	I/O
44	I/O
45	I/O
46	V _{CCA}
47	V _{CCI}
48	GND
49	I/O
50	I/O
51	I/O
52	I/O
53	I/O
54	I/O
55	I/O
56	I/O
57	V _{CCA}
58	GND
59	I/O
60	V _{CCA}
61	GND
62	I/O
63	I/O
64	I/O
65	I/O
66	I/O
67	I/O
68	V _{CCI}
69	GND
70	I/O

84-Pin CQFP	
Pin Number	HiRel A54SX32A Function
71	I/O
72	CLKA
73	CLKB
74	PRA, I/O
75	I/O
76	I/O
77	I/O
78	GND
79	V _{CCA}
80	I/O
81	I/O
82	TCK, I/O
83	TDI, I/O
84	I/O

208-Pin CQFP

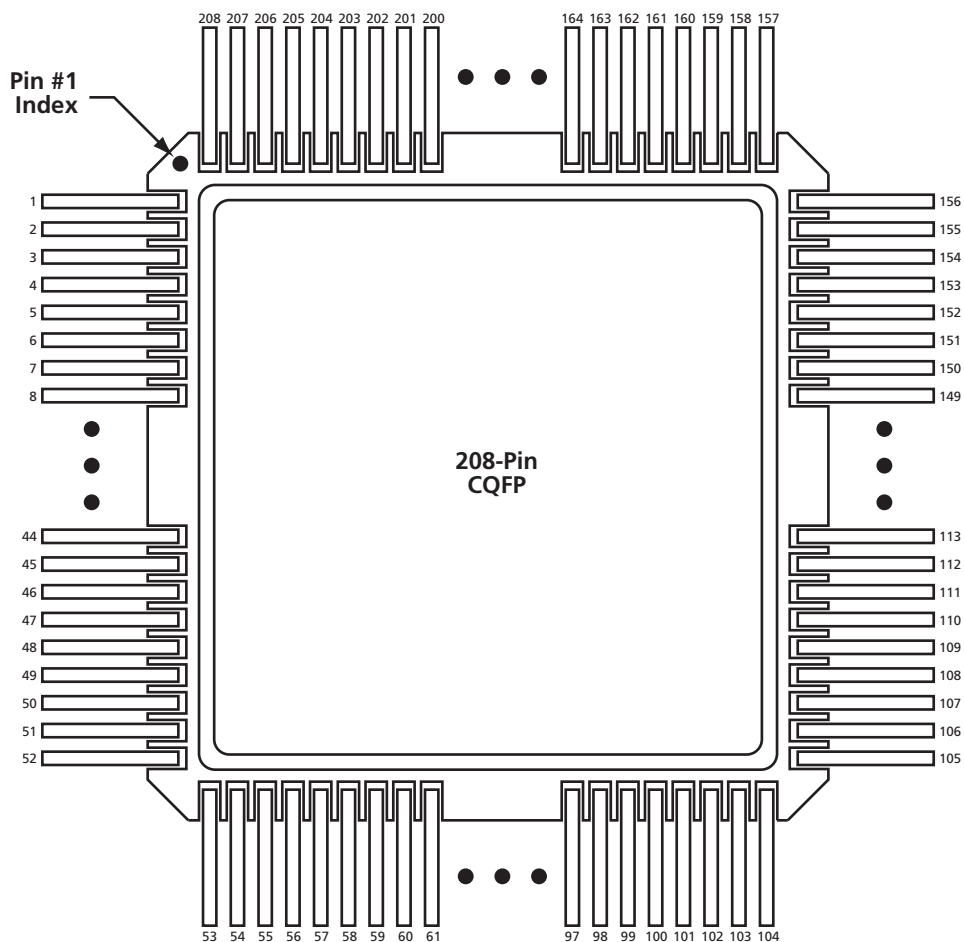

Figure 2-2 • 208-Pin CQFP (Top View)

Note

For Package Manufacturing and Environmental information, visit the Package Resource Center at www.actel.com/products/rescenter/package/index.html.

HiRel SX-A Family FPGAs

208-Pin CQFP		
Pin Number	HiRel A54SX32A Function	HiRel A54SX72A Function
1	GND	GND
2	TDI, I/O	TDI, I/O
3	I/O	I/O
4	I/O	I/O
5	I/O	I/O
6	I/O	I/O
7	I/O	I/O
8	I/O	I/O
9	I/O	I/O
10	I/O	I/O
11	TMS	TMS
12	V _{CCI}	V _{CCI}
13	I/O	I/O
14	I/O	I/O
15	I/O	I/O
16	I/O	I/O
17	I/O	I/O
18	I/O	GND
19	I/O	V _{CCA}
20	I/O	I/O
21	I/O	I/O
22	I/O	I/O
23	I/O	I/O
24	I/O	I/O
25	NC	I/O
26	GND	GND
27	V _{CCA}	V _{CCA}
28	GND	GND
29	I/O	I/O
30	TRST, I/O	TRST, I/O
31	I/O	I/O
32	I/O	I/O
33	I/O	I/O
34	I/O	I/O
35	I/O	I/O
36	I/O	I/O
37	I/O	I/O

208-Pin CQFP		
Pin Number	HiRel A54SX32A Function	HiRel A54SX72A Function
38	I/O	I/O
39	I/O	I/O
40	V _{CCI}	V _{CCI}
41	V _{CCA}	V _{CCA}
42	I/O	I/O
43	I/O	I/O
44	I/O	I/O
45	I/O	I/O
46	I/O	I/O
47	I/O	I/O
48	I/O	I/O
49	I/O	I/O
50	I/O	I/O
51	I/O	I/O
52	GND	GND
53	I/O	I/O
54	I/O	I/O
55	I/O	I/O
56	I/O	I/O
57	I/O	I/O
58	I/O	I/O
59	I/O	I/O
60	V _{CCI}	V _{CCI}
61	I/O	I/O
62	I/O	I/O
63	I/O	I/O
64	I/O	I/O
65	NC	I/O
66	I/O	I/O
67	I/O	I/O
68	I/O	I/O
69	I/O	I/O
70	I/O	I/O
71	I/O	I/O
72	I/O	I/O
73	I/O	I/O
74	I/O	QCLKA

208-Pin CQFP		
Pin Number	HiRel A54SX32A Function	HiRel A54SX72A Function
75	I/O	I/O
76	PRB, I/O	PRB, I/O
77	GND	GND
78	V _{CCA}	V _{CCA}
79	GND	GND
80	NC	NC
81	I/O	I/O
82	HCLK	HCLK
83	I/O	V _{CCI}
84	I/O	QCLKB
85	I/O	I/O
86	I/O	I/O
87	I/O	I/O
88	I/O	I/O
89	I/O	I/O
90	I/O	I/O
91	I/O	I/O
92	I/O	I/O
93	I/O	I/O
94	I/O	I/O
95	I/O	I/O
96	I/O	I/O
97	I/O	I/O
98	V _{CCI}	V _{CCI}
99	I/O	I/O
100	I/O	I/O
101	I/O	I/O
102	I/O	I/O
103	TDO, I/O	TDO, I/O
104	I/O	I/O
105	GND	GND
106	I/O	I/O
107	I/O	I/O
108	I/O	I/O
109	I/O	I/O
110	I/O	I/O
111	I/O	I/O

208-Pin CQFP		
Pin Number	HiRel A54SX32A Function	HiRel A54SX72A Function
112	I/O	I/O
113	I/O	I/O
114	V _{CCA}	V _{CCA}
115	V _{CCI}	V _{CCI}
116	I/O	GND
117	I/O	V _{CCA}
118	I/O	I/O
119	I/O	I/O
120	I/O	I/O
121	I/O	I/O
122	I/O	I/O
123	I/O	I/O
124	I/O	I/O
125	I/O	I/O
126	I/O	I/O
127	I/O	I/O
128	I/O	I/O
129	GND	GND
130	V _{CCA}	V _{CCA}
131	GND	GND
132	NC	I/O
133	I/O	I/O
134	I/O	I/O
135	I/O	I/O
136	I/O	I/O
137	I/O	I/O
138	I/O	I/O
139	I/O	I/O
140	I/O	I/O
141	I/O	I/O
142	I/O	I/O
143	I/O	I/O
144	I/O	I/O
145	V _{CCA}	V _{CCA}
146	GND	GND
147	I/O	I/O
148	V _{CCI}	V _{CCI}

208-Pin CQFP		
Pin Number	HiRel A54SX32A Function	HiRel A54SX72A Function
149	I/O	I/O
150	I/O	I/O
151	I/O	I/O
152	I/O	I/O
153	I/O	I/O
154	I/O	I/O
155	I/O	I/O
156	I/O	I/O
157	GND	GND
158	I/O	I/O
159	I/O	I/O
160	I/O	I/O
161	I/O	I/O
162	I/O	I/O
163	I/O	I/O
164	V _{CCI}	V _{CCI}
165	I/O	I/O
166	I/O	I/O
167	I/O	I/O
168	I/O	I/O
169	I/O	I/O
170	I/O	I/O
171	I/O	I/O
172	I/O	I/O
173	I/O	I/O
174	I/O	I/O
175	I/O	I/O
176	I/O	I/O
177	I/O	I/O
178	I/O	QCLKD
179	I/O	I/O
180	CLKA	CLKA
181	CLKB	CLKB
182	NC	NC
183	GND	GND
184	V _{CCA}	V _{CCA}
185	GND	GND

208-Pin CQFP		
Pin Number	HiRel A54SX32A Function	HiRel A54SX72A Function
186	PRA, I/O	PRA, I/O
187	I/O	V _{CCI}
188	I/O	I/O
189	I/O	I/O
190	I/O	QCLKC
191	I/O	I/O
192	I/O	I/O
193	I/O	I/O
194	I/O	I/O
195	I/O	I/O
196	I/O	I/O
197	I/O	I/O
198	I/O	I/O
199	I/O	I/O
200	I/O	I/O
201	V _{CCI}	V _{CCI}
202	I/O	I/O
203	I/O	I/O
204	I/O	I/O
205	I/O	I/O
206	I/O	I/O
207	I/O	I/O
208	TCK, I/O	TCK, I/O

256-Pin CQFP

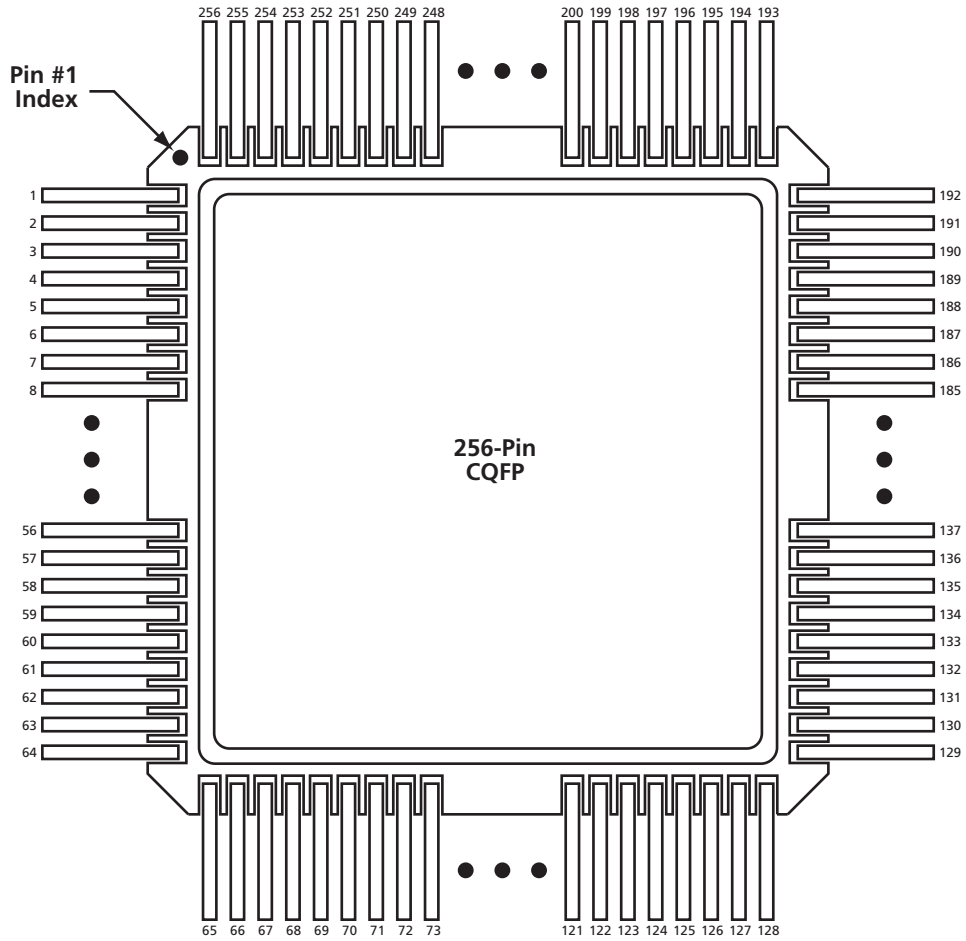

Figure 2-3 • 256-Pin CQFP (Top View)

Note

For Package Manufacturing and Environmental information, visit the Package Resource Center at www.actel.com/products/rescenter/package/index.html.

256-Pin CQFP		
Pin Number	HiRel A54SX32A Function	HiRel A54SX72A Function
1	GND	GND
2	TDI, I/O	TDI, I/O
3	I/O	I/O
4	I/O	I/O
5	I/O	I/O
6	I/O	I/O
7	I/O	I/O
8	I/O	I/O
9	I/O	I/O
10	I/O	I/O
11	TMS	TMS
12	I/O	I/O
13	I/O	I/O
14	I/O	I/O
15	I/O	I/O
16	I/O	I/O
17	I/O	V _{CCI}
18	I/O	I/O
19	I/O	I/O
20	I/O	I/O
21	I/O	I/O
22	I/O	I/O
23	I/O	I/O
24	I/O	I/O
25	I/O	I/O
26	I/O	I/O
27	I/O	I/O
28	V _{CCI}	V _{CCI}
29	GND	GND
30	V _{CCA}	V _{CCA}
31	GND	GND
32	I/O	I/O
33	I/O	I/O
34	TRST, I/O	TRST, I/O
35	I/O	I/O
36	I/O	V _{CCA}
37	I/O	GND

256-Pin CQFP		
Pin Number	HiRel A54SX32A Function	HiRel A54SX72A Function
38	I/O	I/O
39	I/O	I/O
40	I/O	I/O
41	I/O	I/O
42	I/O	I/O
43	I/O	I/O
44	I/O	I/O
45	I/O	I/O
46	V _{CCA}	V _{CCA}
47	I/O	V _{CCI}
48	I/O	I/O
49	I/O	I/O
50	I/O	I/O
51	I/O	I/O
52	I/O	I/O
53	I/O	I/O
54	I/O	I/O
55	I/O	I/O
56	I/O	GND
57	I/O	I/O
58	I/O	I/O
59	GND	GND
60	I/O	I/O
61	I/O	I/O
62	I/O	I/O
63	I/O	I/O
64	I/O	I/O
65	I/O	I/O
66	I/O	I/O
67	I/O	I/O
68	I/O	I/O
69	I/O	I/O
70	I/O	I/O
71	I/O	I/O
72	I/O	I/O
73	I/O	V _{CCI}
74	I/O	I/O

256-Pin CQFP		
Pin Number	HiRel A54SX32A Function	HiRel A54SX72A Function
75	I/O	I/O
76	I/O	I/O
77	I/O	I/O
78	I/O	I/O
79	I/O	I/O
80	I/O	I/O
81	I/O	I/O
82	I/O	I/O
83	I/O	I/O
84	I/O	I/O
85	I/O	I/O
86	I/O	I/O
87	I/O	I/O
88	I/O	I/O
89	I/O	QCLKA
90	PRB, I/O	PRB, I/O
91	GND	GND
92	V _{CCI}	V _{CCI}
93	GND	GND
94	V _{CCA}	V _{CCA}
95	I/O	I/O
96	HCLK	HCLK
97	I/O	I/O
98	I/O	QCLKB
99	I/O	I/O
100	I/O	I/O
101	I/O	I/O
102	I/O	I/O
103	I/O	I/O
104	I/O	I/O
105	I/O	I/O
106	I/O	I/O
107	I/O	I/O
108	I/O	I/O
109	I/O	I/O
110	GND	GND
111	I/O	I/O

256-Pin CQFP		
Pin Number	HiRel A54SX32A Function	HiRel A54SX72A Function
112	I/O	I/O
113	I/O	I/O
114	I/O	I/O
115	I/O	I/O
116	I/O	I/O
117	I/O	I/O
118	I/O	I/O
119	I/O	I/O
120	I/O	V _{CCI}
121	I/O	I/O
122	I/O	I/O
123	I/O	I/O
124	I/O	I/O
125	I/O	I/O
126	TDO, I/O	TDO, I/O
127	I/O	I/O
128	GND	GND
129	I/O	I/O
130	I/O	I/O
131	I/O	I/O
132	I/O	I/O
133	I/O	I/O
134	I/O	I/O
135	I/O	I/O
136	I/O	I/O
137	I/O	I/O
138	I/O	I/O
139	I/O	I/O
140	I/O	I/O
141	V _{CCA}	V _{CCA}
142	I/O	V _{CCI}
143	I/O	GND
144	I/O	V _{CCA}
145	I/O	I/O
146	I/O	I/O
147	I/O	I/O
148	I/O	I/O

256-Pin CQFP		
Pin Number	HiRel A54SX32A Function	HiRel A54SX72A Function
149	I/O	I/O
150	I/O	I/O
151	I/O	I/O
152	I/O	I/O
153	I/O	I/O
154	I/O	I/O
155	I/O	I/O
156	I/O	I/O
157	I/O	I/O
158	GND	GND
159	NC	NC
160	GND	GND
161	V _{CCI}	V _{CCI}
162	I/O	V _{CCA}
163	I/O	I/O
164	I/O	I/O
165	I/O	I/O
166	I/O	I/O
167	I/O	I/O
168	I/O	I/O
169	I/O	I/O
170	I/O	I/O
171	I/O	I/O
172	I/O	I/O
173	I/O	I/O
174	V _{CCA}	V _{CCA}
175	GND	GND
176	GND	GND
177	I/O	I/O
178	I/O	I/O
179	I/O	I/O
180	I/O	I/O
181	I/O	I/O
182	I/O	I/O
183	I/O	V _{CCI}
184	I/O	I/O
185	I/O	I/O

256-Pin CQFP		
Pin Number	HiRel A54SX32A Function	HiRel A54SX72A Function
186	I/O	I/O
187	I/O	I/O
188	I/O	I/O
189	GND	GND
190	I/O	I/O
191	I/O	I/O
192	I/O	I/O
193	I/O	I/O
194	I/O	I/O
195	I/O	I/O
196	I/O	I/O
197	I/O	I/O
198	I/O	I/O
199	I/O	I/O
200	I/O	I/O
201	I/O	I/O
202	I/O	V _{CCI}
203	I/O	I/O
204	I/O	I/O
205	I/O	I/O
206	I/O	I/O
207	I/O	I/O
208	I/O	I/O
209	I/O	I/O
210	I/O	I/O
211	I/O	I/O
212	I/O	I/O
213	I/O	I/O
214	I/O	I/O
215	I/O	I/O
216	I/O	I/O
217	I/O	I/O
218	I/O	QCLKD
219	CLKA	CLKA
220	CLKB	CLKB
221	V _{CCI}	V _{CCI}
222	GND	GND

256-Pin CQFP		
Pin Number	HiRel A54SX32A Function	HiRel A54SX72A Function
223	NC	NC
224	GND	GND
225	PRA, I/O	PRA, I/O
226	I/O	I/O
227	I/O	I/O
228	I/O	V _{CCA}
229	I/O	I/O
230	I/O	I/O
231	I/O	QCLKC
232	I/O	I/O
233	I/O	I/O
234	I/O	I/O

256-Pin CQFP		
Pin Number	HiRel A54SX32A Function	HiRel A54SX72A Function
235	I/O	I/O
236	I/O	I/O
237	I/O	I/O
238	I/O	I/O
239	I/O	I/O
240	GND	GND
241	I/O	I/O
242	I/O	I/O
243	I/O	I/O
244	I/O	I/O
245	I/O	I/O

256-Pin CQFP		
Pin Number	HiRel A54SX32A Function	HiRel A54SX72A Function
246	I/O	I/O
247	I/O	I/O
248	I/O	I/O
249	I/O	V _{CCI}
250	I/O	I/O
251	I/O	I/O
252	I/O	I/O
253	I/O	I/O
254	I/O	I/O
255	I/O	I/O
256	TCK, I/O	TCK, I/O

Datasheet Information

List of Changes

The following table lists critical changes that were made in the current version of the document.

Previous version	Changes in current version—v2.0	Page
Advanced v1.2 (December 2002)	The 84-pin CQFP package information was added to the datasheet.	N/A
	The Product Plan table was deleted because all of the devices are production devices.	N/A
	Table 1-6 • Absolute Maximum Ratings ¹ was updated to include V_{CCA} AC supply voltage information. In addition, two notes were added to the table.	1-10
	Notes 1 and 2 were added to Table 1-8 • 3.3 V LVTTTL and 5 V TTL Electrical Specifications.	1-11
	The "HiRel SX-A Timing Model" was updated.	1-17
	The "Hardwired Clock" and "Routed Clock" equations were updated.	1-17
	All of the Timing Characteristic tables were updated because to include the fully characterized data.	N/A
Advanced v1.1	Table 1-8 • 3.3 V LVTTTL and 5 V TTL Electrical Specifications was updated.	1-11
	Table 1-12 • DC Specifications, 3.3 V PCI Operation was updated.	1-14
Preliminary v1.0	The "Ordering Information" section was updated.	ii
	Figure 1-1 • HiRel SX-A Family Interconnect Elements was updated.	1-1
	The "Clock Resources" section was updated.	1-5
	The "I/O Modules" section was updated.	1-6
	Table 1-2 • I/O Features was updated.	1-6
	The "Hot-Swapping" section was updated.	1-7
	Table 1-3 • I/O Characteristics for All I/O Configurations is new.	1-6
	Table 1-4 • Power-Up Time at which I/Os Become Active is new.	1-7
	The "Power Requirements" section was updated.	1-7
	The "Design Considerations" section was updated.	1-8
	Figure 1-10 • Probe Setup was updated.	1-8
	Table 1-6 • Absolute Maximum Ratings ¹ was updated.	1-10
	Table 1-7 • Recommended Operating Conditions was updated.	1-10
	Table 1-9 • Maximum Source and Sink Currents for All I/O Standards is new.	1-11
	Figure 1-15 • HiRel SX-A Timing Model was updated.	1-17
The "Pin Description" section was updated.	1-31	

Previous version	Changes in current version—v2.0 (Continued)	Page
Advanced v0.1	The "Clock Resources" section was updated.	1-5
	The "I/O Modules" section was updated.	1-6
	The "Hot-Swapping" section was updated.	1-7
	The "Power Requirements" section was updated.	1-7
	The "Boundary Scan Testing (BST)" section has been updated.	1-7
	The "Configuring Diagnostic Pins" section has been updated.	1-7
	The "TRST Pin" section has been updated.	1-7
	The "Dedicated Test Mode" section has been updated.	1-7
	The "Development Tool Support" section has been updated.	1-8
	The "HiRel SX-A Probe Circuit Control Pins" section has been updated.	1-8
	The "Pin Description" section was updated.	1-31
	The "Package Characteristics and Mechanical Drawings" section has been eliminated from the datasheet. The mechanical drawings are now contained in a separate document, "Package Characteristics and Mechanical Drawings," available on the Actel web site.	

Datasheet Categories

In order to provide the latest information to designers, some datasheets are published before data has been fully characterized. Datasheets are designated as "Product Brief," "Advanced," "Production," and "Datasheet Supplement." The definitions of these categories are as follows:

Product Brief

The product brief is a summarized version of a datasheet (advanced or production) containing general product information. This brief gives an overview of specific device and family information.

Advanced

This datasheet version contains initial estimated information based on simulation, other products, devices, or speed grades. This information can be used as estimates, but not for production.

Unmarked (production)

This datasheet version contains information that is considered to be final.

Datasheet Supplement

The datasheet supplement gives specific device information for a derivative family that differs from the general family datasheet. The supplement is to be used in conjunction with the datasheet to obtain more detailed information and for specifications that do not differ between the two families.

International Traffic in Arms Regulations (ITAR) and Export Administration Regulations (EAR)

The products described in this datasheet are subject to the International Traffic in Arms Regulations (ITAR) or the Export Administration Regulations (EAR). They may require an approved export license prior to their export. An export can include a release or disclosure to a foreign national inside or outside the United States.

Actel and the Actel logo are registered trademarks of Actel Corporation.
All other trademarks are the property of their owners.



www.actel.com

Actel Corporation

2061 Stierlin Court
Mountain View, CA
94043-4655 USA

Phone 650.318.4200

Fax 650.318.4600

Actel Europe Ltd.

River Court, Meadows Business Park
Station Approach, Blackwater
Camberley, Surrey GU17 9AB
United Kingdom

Phone +44 (0) 1276 609 300

Fax +44 (0) 1276 607 540

Actel Japan

EXOS Ebisu Bldg. 4F
1-24-14 Ebisu Shibuya-ku
Tokyo 150 Japan

Phone +81.03.3445.7671

Fax +81.03.3445.7668

www.jp.actel.com

Actel Hong Kong

Suite 2114, Two Pacific Place
88 Queensway, Admiralty
Hong Kong

Phone +852 2185 6460

Fax +852 2185 6488

www.actel.com.cn