

# IGLOOe Low Power Flash FPGAs with Flash\*Freeze Technology

## Features and Benefits

### Low Power

- 1.2 V to 1.5 V Core Voltage Support for Low Power
- Supports Single-Voltage System Operation
- Low-Power Active FPGA Operation
- Flash\*Freeze Technology Enables Ultra-Low Power Consumption while Maintaining FPGA Content
- Flash\*Freeze Pin Allows Easy Entry to / Exit from Ultra-Low-Power Flash\*Freeze Mode

### High Capacity

- 600 k to 3 Million System Gates
- 108 to 504 kbits of True Dual-Port SRAM
- Up to 620 User I/Os

### Reprogrammable Flash Technology

- 130-nm, 7-Layer Metal (6 Copper), Flash-Based CMOS Process
- Instant On Level 0 Support
- Single-Chip Solution
- Retains Programmed Design when Powered Off
- 250 MHz (1.5 V systems) and 160 MHz (1.2 V systems) System Performance

### In-System Programming (ISP) and Security

- ISP Using On-Chip 128-Bit Advanced Encryption Standard (AES) Decryption via JTAG (IEEE 1532-compliant)
- FlashLock<sup>®</sup> Designed to Secure FPGA Contents

### High-Performance Routing Hierarchy

- Segmented, Hierarchical Routing and Clock Structure
- High-Performance, Low-Skew Global Network
- Architecture Supports Ultra-High Utilization

### Pro (Professional) I/O

- 700 Mbps DDR, LVDS-Capable I/Os
- 1.2 V, 1.5 V, 1.8 V, 2.5 V, and 3.3 V Mixed-Voltage Operation

- Bank-Selectable I/O Voltages—Up to 8 Banks per Chip
- Single-Ended I/O Standards: LVTTL, LVCMOS 3.3 V / 2.5 V / 1.8 V / 1.5 V / 1.2 V, 3.3 V PCI / 3.3 V PCI-X, and LVCMOS 2.5 V / 5.0 V Input
- Differential I/O Standards: LVPECL, LVDS, B-LVDS, and M-LVDS
- Voltage-Referenced I/O Standards: GTL+ 2.5 V / 3.3 V, GTL 2.5 V / 3.3 V, HSTL Class I and II, SSTL2 Class I and II, SSTL3 Class I and II
- Wide Range Power Supply Voltage Support per JESD8-B, Allowing I/Os to Operate from 2.7 V to 3.6 V
- Wide Range Power Supply Voltage Support per JESD8-12, Allowing I/Os to Operate from 1.14 V to 1.575 V
- I/O Registers on Input, Output, and Enable Paths
- Hot-Swappable and Cold-Sparing I/Os
- Programmable Output Slew Rate and Drive Strength
- Programmable Input Delay
- Schmitt Trigger Option on Single-Ended Inputs
- Weak Pull-Up/-Down
- IEEE 1149.1 (JTAG) Boundary Scan Test
- Pin-Compatible Packages across the IGLOO<sup>®</sup>e Family

### Clock Conditioning Circuit (CCC) and PLL

- Six CCC Blocks, Each with an Integrated PLL
- Configurable Phase Shift, Multiply/Divide, Delay Capabilities, and External Feedback
- Wide Input Frequency Range (1.5 MHz up to 250 MHz)

### Embedded Memory

- 1 kbit of FlashROM User Nonvolatile Memory
- SRAMs and FIFOs with Variable-Aspect-Ratio 4,608-Bit RAM Blocks (×1, ×2, ×4, ×9, and ×18 organizations available)
- True Dual-Port SRAM (except ×18)

### ARM Processor Support in IGLOOe FPGAs

- M1 IGLOOe Devices—Cortex™-M1 Soft Processor Available with or without Debug

**Table 1 • IGLOOe Product Family**

IGLOOe Devices	AGLE600	AGLE3000
ARM-Enabled IGLOOe Devices		M1AGLE3000
System Gates	600,000	3,000,000
VersaTiles (D-flip-flops)	13,824	75,264
Quiescent Current (typical) in Flash*Freeze Mode (µW)	49	137
RAM kbits (1,024 bits)	108	504
4,608-Bit Blocks	24	112
FlashROM Kbits (1,024 bits)	1	1
Secure (AES) ISP	Yes	Yes
CCCs with Integrated PLLs	6	6
VersaNet Globals <sup>1</sup>	18	18
I/O Banks	8	8
Maximum User I/Os	270	620
Package Pins FBGA	FG256, FG484	FG484, FG896

**Notes:**

1. Refer to the [Cortex-M1 Handbook](#) for more information.
2. Six chip (main) and twelve quadrant global networks are available.
3. For devices supporting lower densities, refer to the [IGLOO Low-Power Flash FPGAs with Flash\\*Freeze Technology datasheet](#).

## I/Os Per Package <sup>1</sup>

IGLOOe Devices	AGLE600		AGLE3000	
ARM-Enabled IGLOOe Devices			M1AGLE3000	
Package	I/O Types			
	Single-Ended I/O <sup>1</sup>	Differential I/O Pairs	Single-Ended I/O <sup>1</sup>	Differential I/O Pairs
FG256	165	79	–	–
FG484	270	135	341	168
FG896	–	–	620	310

### Notes:

- When considering migrating your design to a lower- or higher-density device, refer to the [IGLOOe FPGA Fabric User's Guide](#) to ensure compliance with design and board migration requirements.
- Each used differential I/O pair reduces the number of single-ended I/Os available by two.
- For AGL3000 devices, the usage of certain I/O standards is limited as follows:
  - SSTL3(I) and (II): up to 40 I/Os per north or south bank
  - LVPECL / GTL+ 3.3 V / GTL 3.3 V: up to 48 I/Os per north or south bank
  - SSTL2(I) and (II) / GTL+ 2.5 V / GTL 2.5 V: up to 72 I/Os per north or south bank
- FG256 and FG484 are footprint-compatible packages.
- When using voltage-referenced I/O standards, one I/O pin should be assigned as a voltage-referenced pin (VREF) per minibank (group of I/Os).
- When the Flash\*Freeze pin is used to directly enable Flash\*Freeze mode and not as a regular I/O, the number of single-ended user I/Os available is reduced by one.
- "G" indicates RoHS-compliant packages. Refer to "[IGLOOe Ordering Information](#)" on page III for the location of the "G" in the part number.

## IGLOOe FPGAs Package Sizes Dimensions

Package	FG256	FG484	FG896
Length × Width (mm × mm)	17 × 17	23 × 23	31 × 31
Nominal Area (mm <sup>2</sup> )	289	529	961
Pitch (mm)	1	1	1
Height (mm)	1.6	2.23	2.23

## IGLOOe Device Status

IGLOOe Devices	Status	M1 IGLOOe Devices	Status
AGLE600	Production		
AGLE3000	Production	M1AGLE3000	Production

## IGLOOe Ordering Information

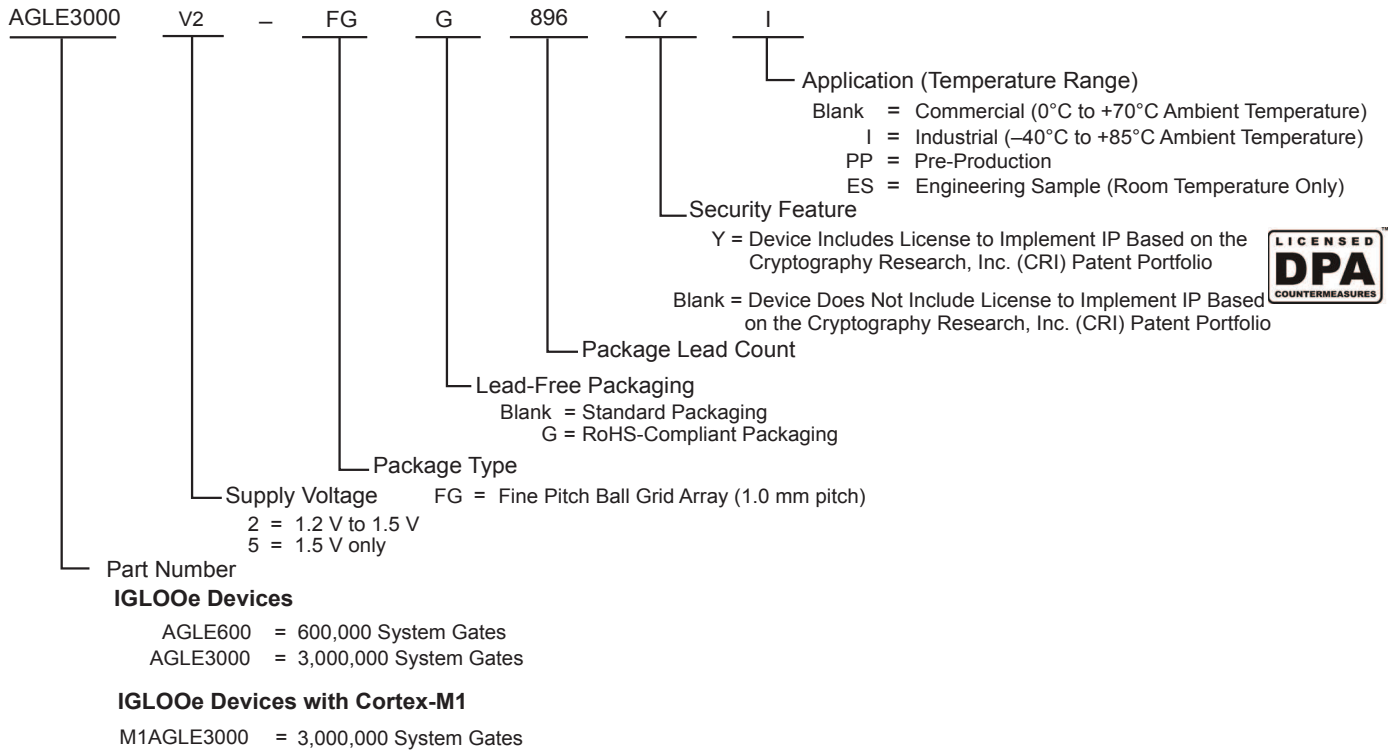

*Note: Marking Information: IGLOO V2 devices do not have V2 marking, but IGLOO V5 devices are marked accordingly.*

## Temperature Grade Offerings

Package	AGLE600	AGLE3000
		M1AGLPE3000
FG256	C, I	–
FG484	C, I	C, I
FG896	–	C, I

*Note:* C = Commercial temperature range: 0°C to 70°C ambient temperature.  
 I = Industrial temperature range: –40°C to 85°C ambient temperature.

References made to IGLOOe devices also apply to ARM-enabled IGLOOe devices. The ARM-enabled part numbers start with M1 (Cortex-M1).

Contact your local Microsemi SoC Products Group representative for device availability:

<http://www.microsemi.com/soc/contact/default.aspx>.

---

# Table of Contents

---

## IGLOOe Device Family Overview

General Description .....	1-1
---------------------------	-----

## IGLOOe DC and Switching Characteristics

General Specifications .....	2-1
Calculating Power Dissipation .....	2-7
User I/O Characteristics .....	2-16
VersaTile Characteristics .....	2-82
Global Resource Characteristics .....	2-88
Clock Conditioning Circuits .....	2-91
Embedded SRAM and FIFO Characteristics .....	2-94
Embedded FlashROM Characteristics .....	2-108
JTAG 1532 Characteristics .....	2-109

## Pin Descriptions and Packaging

Supply Pins .....	3-1
User-Defined Supply Pins .....	3-2
User Pins .....	3-3
JTAG Pins .....	3-4
Special Function Pins .....	3-5
Packaging .....	3-5
Related Documents .....	3-6

## Package Pin Assignments

FG256 .....	4-1
FG484 .....	4-5
FG896 .....	4-16

## Datasheet Information

List of Changes .....	5-1
Datasheet Categories .....	5-8
Safety Critical, Life Support, and High-Reliability Applications Policy .....	5-8



---

# 1 – IGLOOe Device Family Overview

---

## General Description

The IGLOOe family of flash FPGAs, based on a 130-nm flash process, offers the lowest power FPGA, a single-chip solution, small footprint packages, reprogrammability, and an abundance of advanced features.

The Flash\*Freeze technology used in IGLOOe devices enables entering and exiting an ultra-low power mode while retaining SRAM and register data. Flash\*Freeze technology simplifies power management through I/O and clock management with rapid recovery to operation mode.

The Low Power Active capability (static idle) allows for ultra-low power consumption while the IGLOOe device is completely functional in the system. This allows the IGLOOe device to control system power management based on external inputs (e.g., scanning for keyboard stimulus) while consuming minimal power.

Nonvolatile flash technology gives IGLOOe devices the advantage of being a secure, low power, single-chip solution that is Instant On. IGLOOe is reprogrammable and offers time-to-market benefits at an ASIC-level unit cost.

These features enable designers to create high-density systems using existing ASIC or FPGA design flows and tools.

IGLOOe devices offer 1 kbit of on-chip, programmable, nonvolatile FlashROM storage as well as clock conditioning circuitry based on 6 integrated phase-locked loops (PLLs). IGLOOe devices have up to 3 million system gates, supported with up to 504 kbits of true dual-port SRAM and up to 620 user I/Os.

M1 IGLOOe devices support the high-performance, 32-bit Cortex-M1 processor developed by ARM for implementation in FPGAs. Cortex-M1 is a soft processor that is fully implemented in the FPGA fabric. It has a three-stage pipeline that offers a good balance between low power consumption and speed when implemented in an M1 IGLOOe device. The processor runs the ARMv6-M instruction set, has a configurable nested interrupt controller, and can be implemented with or without the debug block. Cortex-M1 is available for free from Microsemi for use in M1 IGLOOe FPGAs.

The ARM-enabled devices have Microsemi ordering numbers that begin with M1AGLE and do not support AES decryption.

## Flash\*Freeze Technology

The IGLOOe device offers unique Flash\*Freeze technology, allowing the device to enter and exit ultra-low power Flash\*Freeze mode. IGLOOe devices do not need additional components to turn off I/Os or clocks while retaining the design information, SRAM content, and registers. Flash\*Freeze technology is combined with in-system programmability, which enables users to quickly and easily upgrade and update their designs in the final stages of manufacturing or in the field. The ability of IGLOOe V2 devices to support a wide range of core voltage (1.2 V to 1.5 V) allows further reduction in power consumption, thus achieving the lowest total system power.

When the IGLOOe device enters Flash\*Freeze mode, the device automatically shuts off the clocks and inputs to the FPGA core; when the device exits Flash\*Freeze mode, all activity resumes and data is retained.

The availability of low power modes, combined with reprogrammability, a single-chip and single-voltage solution, and availability of small-footprint, high pin-count packages, make IGLOOe devices the best fit for portable electronics.

## Flash Advantages

### **Low Power**

Flash-based IGLOOe devices exhibit power characteristics similar to those of an ASIC, making them an ideal choice for power-sensitive applications. IGLOOe devices have only a very limited power-on current surge and no high-current transition period, both of which occur on many FPGAs.

IGLOOe devices also have low dynamic power consumption to further maximize power savings; power is even further reduced by the use of a 1.2 V core voltage.

Low dynamic power consumption, combined with low static power consumption and Flash\*Freeze technology, gives the IGLOOe device the lowest total system power offered by any FPGA.

### **Security**

The nonvolatile, flash-based IGLOOe devices do not require a boot PROM, so there is no vulnerable external bitstream that can be easily copied. IGLOOe devices incorporate FlashLock, which provides a unique combination of reprogrammability and design security without external overhead, advantages that only an FPGA with nonvolatile flash programming can offer.

IGLOOe devices utilize a 128-bit flash-based lock and a separate AES key to provide the highest level of protection in the FPGA industry for programmed intellectual property and configuration data. In addition, all FlashROM data in IGLOOe devices can be encrypted prior to loading, using the industry-leading AES-128 (FIPS192) bit block cipher encryption standard. AES was adopted by the National Institute of Standards and Technology (NIST) in 2000 and replaces the 1977 DES standard. IGLOOe devices have a built-in AES decryption engine and a flash-based AES key that make them the most comprehensive programmable logic device security solution available today. IGLOOe devices with AES-based security provide a high level of protection for remote field updates over public networks such as the Internet, and are designed to ensure that valuable IP remains out of the hands of system overbuilders, system cloners, and IP thieves.

Security, built into the FPGA fabric, is an inherent component of the IGLOOe family. The flash cells are located beneath seven metal layers, and many device design and layout techniques have been used to make invasive attacks extremely difficult. The IGLOOe family, with FlashLock and AES security, is unique in being highly resistant to both invasive and noninvasive attacks. Your valuable IP is protected with industry-standard security, making remote ISP possible. An IGLOOe device provides the best available security for programmable logic designs.

### **Single Chip**

Flash-based FPGAs store their configuration information in on-chip flash cells. Once programmed, the configuration data is an inherent part of the FPGA structure, and no external configuration data needs to be loaded at system power-up (unlike SRAM-based FPGAs). Therefore, flash-based IGLOOe FPGAs do not require system configuration components such as EEPROMs or microcontrollers to load device configuration data. This reduces bill-of-materials costs and PCB area, and increases security and system reliability.

### **Instant On**

Flash-based IGLOOe devices support Level 0 of the Instant On classification standard. This feature helps in system component initialization, execution of critical tasks before the processor wakes up, setup and configuration of memory blocks, clock generation, and bus activity management. The Instant On feature of flash-based IGLOOe devices greatly simplifies total system design and reduces total system cost, often eliminating the need for CPLDs and clock generation PLLs. In addition, glitches and brownouts in system power will not corrupt the IGLOOe device's flash configuration, and unlike SRAM-based FPGAs, the device will not have to be reloaded when system power is restored. This enables the reduction or complete removal of the configuration PROM, expensive voltage monitor, brownout detection, and clock generator devices from the PCB design. Flash-based IGLOOe devices simplify total system design and reduce cost and design risk while increasing system reliability and improving system initialization time.

## **Reduced Cost of Ownership**

Advantages to the designer extend beyond low unit cost, performance, and ease of use. Unlike SRAM-based FPGAs, Flash-based IGLOOe devices allow all functionality to be Instant On; no external boot PROM is required. On-board security mechanisms prevent access to all the programming information and enable secure remote updates of the FPGA logic. Designers can perform secure remote in-system reprogramming to support future design iterations and field upgrades with confidence that valuable intellectual property cannot be compromised or copied. Secure ISP can be performed using the industry-standard AES algorithm. The IGLOOe family device architecture mitigates the need for ASIC migration at higher user volumes. This makes the IGLOOe family a cost-effective ASIC replacement solution, especially for applications in the consumer, networking/communications, computing, and avionics markets.

## **Firm-Error Immunity**

Firm errors occur most commonly when high-energy neutrons, generated in the upper atmosphere, strike a configuration cell of an SRAM FPGA. The energy of the collision can change the state of the configuration cell and thus change the logic, routing, or I/O behavior in an unpredictable way. These errors are impossible to prevent in SRAM FPGAs. The consequence of this type of error can be a complete system failure. Firm errors do not exist in the configuration memory of IGLOOe flash-based FPGAs. Once it is programmed, the flash cell configuration element of IGLOOe FPGAs cannot be altered by high-energy neutrons and is therefore immune to them. Recoverable (or soft) errors occur in the user data SRAM of all FPGA devices. These can easily be mitigated by using error detection and correction (EDAC) circuitry built into the FPGA fabric.

## **Advanced Flash Technology**

The IGLOOe family offers many benefits, including nonvolatility and reprogrammability, through an advanced flash-based, 130-nm LVCMOS process with seven layers of metal. Standard CMOS design techniques are used to implement logic and control functions. The combination of fine granularity, enhanced flexible routing resources, and abundant flash switches allows for very high logic utilization without compromising device routability or performance. Logic functions within the device are interconnected through a four-level routing hierarchy.

IGLOOe family FPGAs utilize design and process techniques to minimize power consumption in all modes of operation.

## **Advanced Architecture**

The proprietary IGLOOe architecture provides granularity comparable to standard-cell ASICs. The IGLOOe device consists of five distinct and programmable architectural features (Figure 1-1 on page 4):

- Flash\*Freeze technology
- FPGA VersaTiles
- Dedicated FlashROM
- Dedicated SRAM/FIFO memory
- Extensive CCCs and PLLs
- Pro I/O structure

The FPGA core consists of a sea of VersaTiles. Each VersaTile can be configured as a three-input logic function, a D-flip-flop (with or without enable), or a latch by programming the appropriate flash switch interconnections. The versatility of the IGLOOe core tile as either a three-input lookup table (LUT) equivalent or a D-flip-flop/latch with enable allows for efficient use of the FPGA fabric. The VersaTile capability is unique to the Microsemi ProASIC® family of third-generation-architecture flash FPGAs. VersaTiles are connected with any of the four levels of routing hierarchy. Flash switches are distributed throughout the device to provide nonvolatile, reconfigurable interconnect programming. Maximum core utilization is possible for virtually any design.

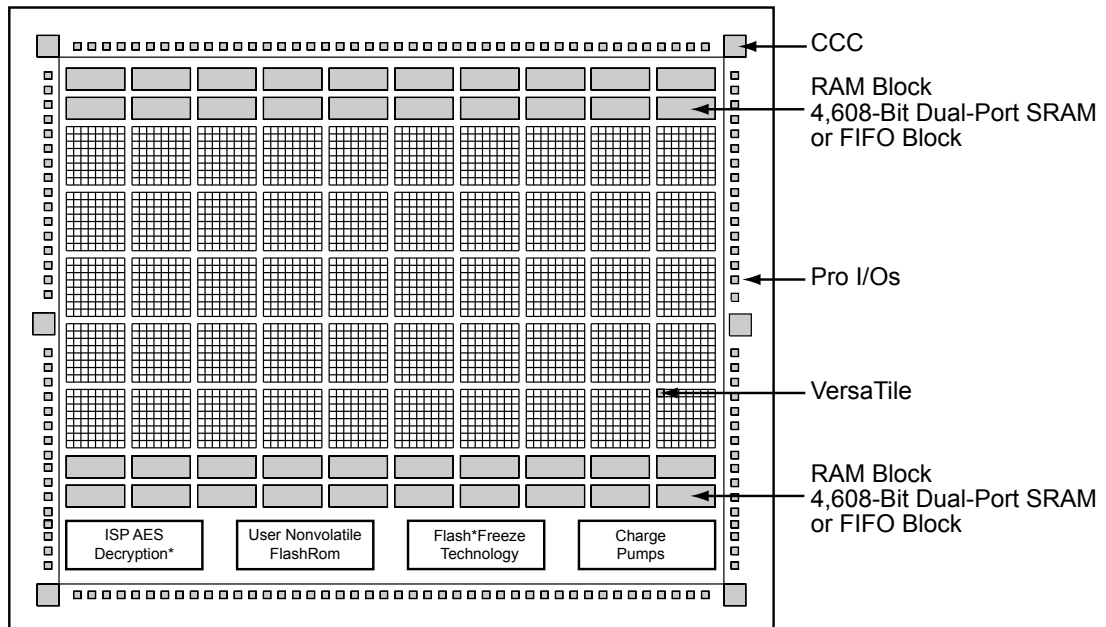

**Figure 1-1 • IGLOOe Device Architecture Overview**

### **Flash\*Freeze Technology**

The IGLOOe device has an ultra-low power static mode, called Flash\*Freeze mode, which retains all SRAM and register information and can still quickly return to normal operation. Flash\*Freeze technology enables the user to quickly (within 1  $\mu$ s) enter and exit Flash\*Freeze mode by activating the Flash\*Freeze pin while all power supplies are kept at their original values. In addition, I/Os and global I/Os can still be driven and can be toggling without impact on power consumption, clocks can still be driven or can be toggling without impact on power consumption, and the device retains all core registers, SRAM information, and states. I/O states are tristated during Flash\*Freeze mode or can be set to a certain state using weak pull-up or pull-down I/O attribute configuration. No power is consumed by the I/O banks, clocks, JTAG pins, or PLL in this mode.

Flash\*Freeze technology allows the user to switch to active mode on demand, thus simplifying the power management of the device.

The Flash\*Freeze pin (active low) can be routed internally to the core to allow the user's logic to decide when it is safe to transition to this mode. It is also possible to use the Flash\*Freeze pin as a regular I/O if Flash\*Freeze mode usage is not planned, which is advantageous because of the inherent low power static and dynamic capabilities of the IGLOOe device. Refer to [Figure 1-2](#) for an illustration of entering/exiting Flash\*Freeze mode.

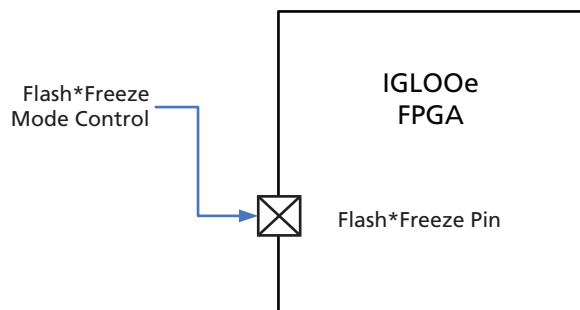

**Figure 1-2 • IGLOOe Flash\*Freeze Mode**

### VersaTiles

The IGLOOe core consists of VersaTiles, which have been enhanced beyond the ProASIC<sup>PLUS</sup>® core tiles. The IGLOOe VersaTile supports the following:

- All 3-input logic functions—LUT-3 equivalent
- Latch with clear or set
- D-flip-flop with clear or set
- Enable D-flip-flop with clear or set

Refer to [Figure 1-3](#) for VersaTile configurations.

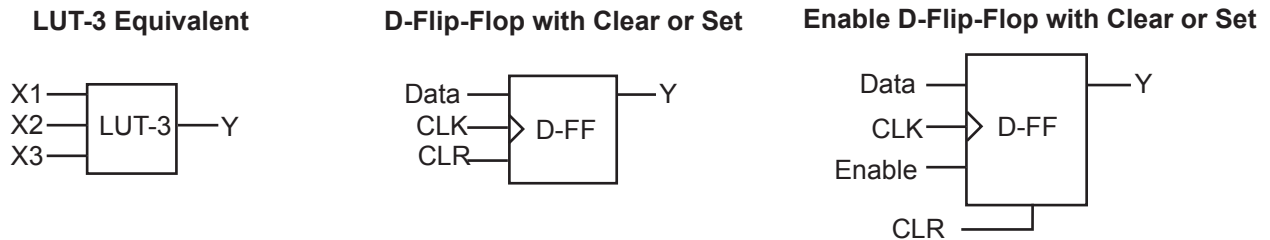

**Figure 1-3 • VersaTile Configurations**

### User Nonvolatile FlashROM

IGLOOe devices have 1 kbit of on-chip, user-accessible, nonvolatile FlashROM. The FlashROM can be used in diverse system applications:

- Internet protocol addressing (wireless or fixed)
- System calibration settings
- Device serialization and/or inventory control
- Subscription-based business models (for example, set-top boxes)
- Secure key storage for secure communications algorithms
- Asset management/tracking
- Date stamping
- Version management

The FlashROM is written using the standard IGLOOe IEEE 1532 JTAG programming interface. The core can be individually programmed (erased and written), and on-chip AES decryption can be used selectively to securely load data over public networks, as in security keys stored in the FlashROM for a user design.

The FlashROM can be programmed via the JTAG programming interface, and its contents can be read back either through the JTAG programming interface or via direct FPGA core addressing. Note that the FlashROM can only be programmed from the JTAG interface and cannot be programmed from the internal logic array.

The FlashROM is programmed as 8 banks of 128 bits; however, reading is performed on a byte-by-byte basis using a synchronous interface. A 7-bit address from the FPGA core defines which of the 8 banks and which of the 16 bytes within that bank are being read. The three most significant bits (MSBs) of the FlashROM address determine the bank, and the four least significant bits (LSBs) of the FlashROM address define the byte.

The IGLOOe development software solutions, Libero<sup>®</sup> System-on-Chip (SoC) and Designer, have extensive support for the FlashROM. One such feature is auto-generation of sequential programming files for applications requiring a unique serial number in each part. Another feature allows the inclusion of static data for system version control. Data for the FlashROM can be generated quickly and easily using Libero SoC and Designer software tools. Comprehensive programming file support is also included to allow for easy programming of large numbers of parts with differing FlashROM contents.

## **SRAM and FIFO**

IGLOOe devices have embedded SRAM blocks along their north and south sides. Each variable-aspect-ratio SRAM block is 4,608 bits in size. Available memory configurations are 256×18, 512×9, 1k×4, 2k×2, and 4k×1 bits. The individual blocks have independent read and write ports that can be configured with different bit widths on each port. For example, data can be sent through a 4-bit port and read as a single bitstream. The embedded SRAM blocks can be initialized via the device JTAG port (ROM emulation mode) using the UJTAG macro.

In addition, every SRAM block has an embedded FIFO control unit. The control unit allows the SRAM block to be configured as a synchronous FIFO without using additional core VersaTiles. The FIFO width and depth are programmable. The FIFO also features programmable Almost Empty (AEMPTY) and Almost Full (AFULL) flags in addition to the normal Empty and Full flags. The embedded FIFO control unit contains the counters necessary for generation of the read and write address pointers. The embedded SRAM/FIFO blocks can be cascaded to create larger configurations.

## **PLL and CCC**

IGLOOe devices provide designers with very flexible clock conditioning capabilities. Each member of the IGLOOe family contains six CCCs, each with an integrated PLL.

The six CCC blocks are located at the four corners and the centers of the east and west sides. One CCC (center west side) has a PLL.

The inputs of the six CCC blocks are accessible from the FPGA core or from one of several inputs located near the CCC that have dedicated connections to the CCC block.

The CCC block has these key features:

- Wide input frequency range ( $f_{IN\_CCC}$ ) = 1.5 MHz up to 250 MHz
- Output frequency range ( $f_{OUT\_CCC}$ ) = 0.75 MHz up to 250 MHz
- 2 programmable delay types for clock skew minimization
- Clock frequency synthesis

Additional CCC specifications:

- Internal phase shift = 0°, 90°, 180°, and 270°. Output phase shift depends on the output divider configuration.
- Output duty cycle = 50% ± 1.5% or better
- Low output jitter: worst case < 2.5% × clock period peak-to-peak period jitter when single global network used
- Maximum acquisition time is 300 μs
- Exceptional tolerance to input period jitter—allowable input jitter is up to 1.5 ns
- Four precise phases; maximum misalignment between adjacent phases of 40 ps × 250 MHz /  $f_{OUT\_CCC}$

## **Global Clocking**

IGLOOe devices have extensive support for multiple clocking domains. In addition to the CCC and PLL support described above, there is a comprehensive global clock distribution network.

Each VersaTile input and output port has access to nine VersaNets: six chip (main) and three quadrant global networks. The VersaNets can be driven by the CCC or directly accessed from the core via multiplexers (MUXes). The VersaNets can be used to distribute low-skew clock signals or for rapid distribution of high-fanout nets.

## Pro I/Os with Advanced I/O Standards

The IGLOOe family of FPGAs features a flexible I/O structure, supporting a range of voltages (1.2 V, 1.5 V, 1.8 V, 2.5 V, 3.0 V wide range, and 3.3 V). IGLOOe FPGAs support 19 different I/O standards, including single-ended, differential, and voltage-referenced. The I/Os are organized into banks, with eight banks per device (two per side). The configuration of these banks determines the I/O standards supported. Each I/O bank is subdivided into VREF minibanks, which are used by voltage-referenced I/Os. VREF minibanks contain 8 to 18 I/Os. All the I/Os in a given minibank share a common VREF line. Therefore, if any I/O in a given VREF minibank is configured as a VREF pin, the remaining I/Os in that minibank will be able to use that reference voltage.

Each I/O module contains several input, output, and enable registers. These registers allow the implementation of the following:

- Single-Data-Rate applications (e.g., PCI 66 MHz, bidirectional SSTL 2 and 3, Class I and II)
- Double-Data-Rate applications (e.g., DDR LVDS, B-LVDS, and M-LVDS I/Os for point-to-point communications, and DDR 200 MHz SRAM using bidirectional HSTL Class II).

IGLOOe banks support M-LVDS with 20 multi-drop points.

Hot-swap (also called hot-plug, or hot-insertion) is the operation of hot-insertion or hot-removal of a card in a powered-up system.

Cold-sparing (also called cold-swap) refers to the ability of a device to leave system data undisturbed when the system is powered up, while the component itself is powered down, or when power supplies are floating.

## Wide Range I/O Support

IGLOOe devices support JEDEC-defined wide range I/O operation. IGLOOe devices support both the JESD8-B specification, covering 3.0 V and 3.3 V supplies, for an effective operating range of 2.7 V to 3.6 V, and JESD8-12 with its 1.2 V nominal, supporting an effective operating range of 1.14 V to 1.575 V.

Wider I/O range means designers can eliminate power supplies or power conditioning components from the board or move to less costly components with greater tolerances. Wide range eases I/O bank management and provides enhanced protection from system voltage spikes, while providing the flexibility to easily run custom voltage applications.

## Specifying I/O States During Programming

You can modify the I/O states during programming in FlashPro. In FlashPro, this feature is supported for PDB files generated from Designer v8.5 or greater. See the [FlashPro User's Guide](#) for more information.

**Note:** PDB files generated from Designer v8.1 to Designer v8.4 (including all service packs) have limited display of Pin Numbers only.

1. Load a PDB from the FlashPro GUI. You must have a PDB loaded to modify the I/O states during programming.
2. From the FlashPro GUI, click **PDB Configuration**. A FlashPoint – Programming File Generator window appears.
3. Click the **Specify I/O States During Programming** button to display the Specify I/O States During Programming dialog box.
4. Sort the pins as desired by clicking any of the column headers to sort the entries by that header. Select the I/Os you wish to modify ([Figure 1-4 on page 1-8](#)).
5. Set the I/O Output State. You can set Basic I/O settings if you want to use the default I/O settings for your pins, or use Custom I/O settings to customize the settings for each pin. Basic I/O state settings:
  - 1 – I/O is set to drive out logic High
  - 0 – I/O is set to drive out logic Low
  - Last Known State – I/O is set to the last value that was driven out prior to entering the programming mode, and then held at that value during programming
  - Z -Tri-State: I/O is tristated

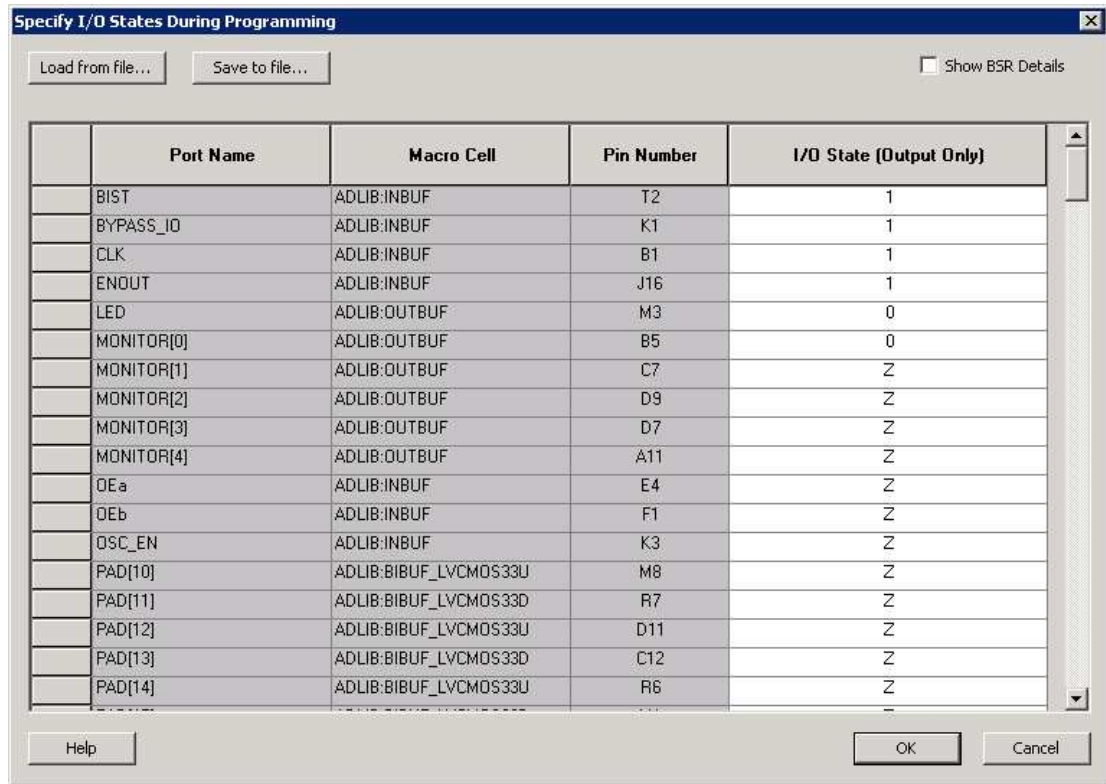

**Figure 1-4 • I/O States During Programming Window**

- Click OK to return to the FlashPoint – Programming File Generator window.

**Note:** I/O States During programming are saved to the ADB and resulting programming files after completing programming file generation.

## 2 – IGLOOe DC and Switching Characteristics

### General Specifications

#### Operating Conditions

Stresses beyond those listed in [Table 2-1](#) may cause permanent damage to the device.

Exposure to absolute maximum rating conditions for extended periods may affect device reliability. Absolute Maximum Ratings are stress ratings only; functional operation of the device at these or any other conditions beyond those listed under the Recommended Operating Conditions specified in [Table 2-2](#) on [page 2-2](#) is not implied.

**Table 2-1 • Absolute Maximum Ratings**

Symbol	Parameter	Limits	Units
VCC	DC core supply voltage	–0.3 to 1.65	V
VJTAG	JTAG DC voltage	–0.3 to 3.75	V
VPUMP	Programming voltage	–0.3 to 3.75	V
VCCPLL	Analog power supply (PLL)	–0.3 to 1.65	V
VCCI and VMV <sup>3</sup>	DC I/O buffer supply voltage	–0.3 to 3.75	V
VI	I/O input voltage	–0.3 V to 3.6 V (when I/O hot insertion mode is enabled) –0.3 V to (VCCI + 1 V) or 3.6 V, whichever voltage is lower (when I/O hot-insertion mode is disabled)	V
T <sub>STG</sub> <sup>2</sup>	Storage temperature	–65 to +150	°C
T <sub>J</sub> <sup>2</sup>	Junction temperature	+125	°C

**Notes:**

1. The device should be operated within the limits specified by the datasheet. During transitions, the input signal may undershoot or overshoot according to the limits shown in [Table 2-4](#) on [page 2-3](#).
2. For flash programming and retention maximum limits, refer to [Table 2-3](#) on [page 2-3](#), and for recommended operating limits, refer to [Table 2-2](#) on [page 2-2](#).
3. VMV pins must be connected to the corresponding VCCI pins. See the "VMVx I/O Supply Voltage (quiet)" section on [page 3-1](#) for further information.

**Table 2-2 • Recommended Operating Conditions <sup>1</sup>**

Symbol	Parameter	Commercial	Industrial	Units	
T <sub>A</sub>	Ambient Temperature	0 to +70	−40 to +85	°C	
T <sub>J</sub>	Junction Temperature <sup>2</sup>	0 to + 85	−40 to +100	°C	
VCC <sup>3</sup>	1.5 V DC core supply voltage <sup>4</sup>	1.425 to 1.575	1.425 to 1.575	V	
	1.2 V–1.5 V wide range DC core voltage <sup>5, 6</sup>	1.14 to 1.575	1.14 to 1.575	V	
VJTAG	JTAG DC voltage	1.4 to 3.6	1.4 to 3.6	V	
VPUMP	Programming voltage <sup>6</sup>	Programming Mode	3.15 to 3.45	3.15 to 3.45	V
		Operation <sup>7</sup>	0 to 3.6	0 to 3.6	V
VCCPLL <sup>8</sup>	Analog power supply (PLL)	1.5 V DC core supply voltage <sup>4</sup>	1.425 to 1.575	1.425 to 1.575	V
		1.2 V–1.5 V DC core supply voltage <sup>5</sup>	1.14 to 1.575	1.14 to 1.575	V
VCCI and VMV <sup>9</sup>	1.2 V DC supply voltage <sup>5</sup>	1.14 to 1.26	1.14 to 1.26	V	
	1.2 V wide range DC supply voltage <sup>5</sup>	1.14 to 1.575	1.14 to 1.575	V	
	1.5 V DC supply voltage	1.425 to 1.575	1.425 to 1.575	V	
	1.8 V DC supply voltage	1.7 to 1.9	1.7 to 1.9	V	
	2.5 V DC supply voltage	2.3 to 2.7	2.3 to 2.7	V	
	3.0 V DC supply voltage <sup>10</sup>	2.7 to 3.6	2.7 to 3.6	V	
	3.3 V DC supply voltage	3.0 to 3.6	3.0 to 3.6	V	
	LVDS differential I/O	2.375 to 2.625	2.375 to 2.625	V	
	LVPECL differential I/O	3.0 to 3.6	3.0 to 3.6	V	

**Notes:**

1. All parameters representing voltages are measured with respect to GND unless otherwise specified.
2. To ensure targeted reliability standards are met across ambient and junction operating temperatures, Microsemi recommends that the user follow best design practices using Microsemi's timing and power simulation tools.
3. The ranges given here are for power supplies only. The recommended input voltage ranges specific to each I/O standard are given in [Table 2-21 on page 2-20](#). VCCI should be at the same voltage within a given I/O bank.
4. For IGLOOe V5 devices
5. For IGLOOe V2 devices only, operating at VCCI ≥ VCC
6. All IGLOOe devices (V5 and V2) must be programmed with the VCC core voltage at 1.5 V. Applications using the V2 devices powered by a 1.2 V supply must switch the core supply to 1.5 V for in-system programming.
7. VPUMP can be left floating during operation (not programming mode).
8. VCCPLL pins should be tied to VCC pins. See the "[VCCPLA/B/C/D/E/F PLL Supply Voltage](#)" section for further information.
9. VMV pins must be connected to the corresponding VCCI pins. See the "[VMVx I/O Supply Voltage \(quiet\)](#)" section for further information.
10. 3.3 V wide range is compliant to the JESD8-B specification and supports 3.0 V VCCI operation.

**Table 2-3 • Flash Programming Limits – Retention, Storage, and Operating Temperature<sup>1</sup>**

Product Grade	Programming Cycles	Program Retention (biased/unbiased)	Maximum Storage Temperature T <sub>STG</sub> (°C) <sup>2</sup>	Maximum Operating Junction Temperature T <sub>J</sub> (°C) <sup>2</sup>
Commercial	500	20 years	110	100
Industrial	500	20 years	110	100

**Notes:**

1. This is a stress rating only; functional operation at any condition other than those indicated is not implied.
2. These limits apply for program/data retention only. Refer to [Table 2-1 on page 2-1](#) and [Table 2-2 for device operating conditions and absolute limits](#).

**Table 2-4 • Overshoot and Undershoot Limits<sup>1, 3</sup>**

VCCI	Average VCCI–GND Overshoot or Undershoot Duration as a Percentage of Clock Cycle <sup>2</sup>	Maximum Overshoot/Undershoot <sup>2</sup>
2.7 V or less	10%	1.4 V
	5%	1.49 V
3 V	10%	1.1 V
	5%	1.19 V
3.3 V	10%	0.79 V
	5%	0.88 V
3.6 V	10%	0.45 V
	5%	0.54 V

**Notes:**

1. Based on reliability requirements at junction temperature at 85°C.
2. The duration is allowed at one out of six clock cycles. If the overshoot/undershoot occurs at one out of two cycles, the maximum overshoot/undershoot has to be reduced by 0.15 V.
3. This table does not provide PCI overshoot/undershoot limits.

## I/O Power-Up and Supply Voltage Thresholds for Power-On Reset (Commercial and Industrial)

Sophisticated power-up management circuitry is designed into every IGLOOe device. These circuits ensure easy transition from the powered-off state to the powered-up state of the device. The many different supplies can power up in any sequence with minimized current spikes or surges. In addition, the I/O will be in a known state through the power-up sequence. The basic principle is shown in [Figure 2-1 on page 2-4](#) and [Figure 2-2 on page 2-5](#).

There are five regions to consider during power-up.

IGLOOe I/Os are activated only if ALL of the following three conditions are met:

1. VCC and VCCI are above the minimum specified trip points ([Figure 2-1 on page 2-4](#) and [Figure 2-2 on page 2-5](#)).
2. VCCI > VCC – 0.75 V (typical)
3. Chip is in the operating mode.

**VCCI Trip Point:**

Ramping up: 0.6 V < trip\_point\_up < 1.2 V

Ramping down: 0.5 V < trip\_point\_down < 1.1 V

**VCC Trip Point:**

Ramping up: 0.6 V < trip\_point\_up < 1.1 V

Ramping down: 0.5 V < trip\_point\_down < 1 V

VCC and VCCI ramp-up trip points are about 100 mV higher than ramp-down trip points. This specifically built-in hysteresis prevents undesirable power-up oscillations and current surges. Note the following:

- During programming, I/Os become tristated and weakly pulled up to VCCI.

- JTAG supply, PLL power supplies, and charge pump VPUMP supply have no influence on I/O behavior.

### PLL Behavior at Brownout Condition

Microsemi recommends using monotonic power supplies or voltage regulators to ensure proper powerup behavior. Power ramp-up should be monotonic at least until VCC and VCCPLX exceed brownout activation levels. The VCC activation level is specified as 1.1 V worst-case (see Figure 2-1 and Figure 2-2 on page 2-5 for more details).

When PLL power supply voltage and/or VCC levels drop below the VCC brownout levels ( $0.75\text{ V} \pm 0.25\text{ V}$ ), the PLL output lock signal goes low and/or the output clock is lost. Refer to the "Power-Up/-Down Behavior of Low Power Flash Devices" chapter of the *IGLOOe FPGA Fabric User's Guide* for information on clock and lock recovery.

### Internal Power-Up Activation Sequence

1. Core
2. Input buffers

Output buffers, after 200 ns delay from input buffer activation.

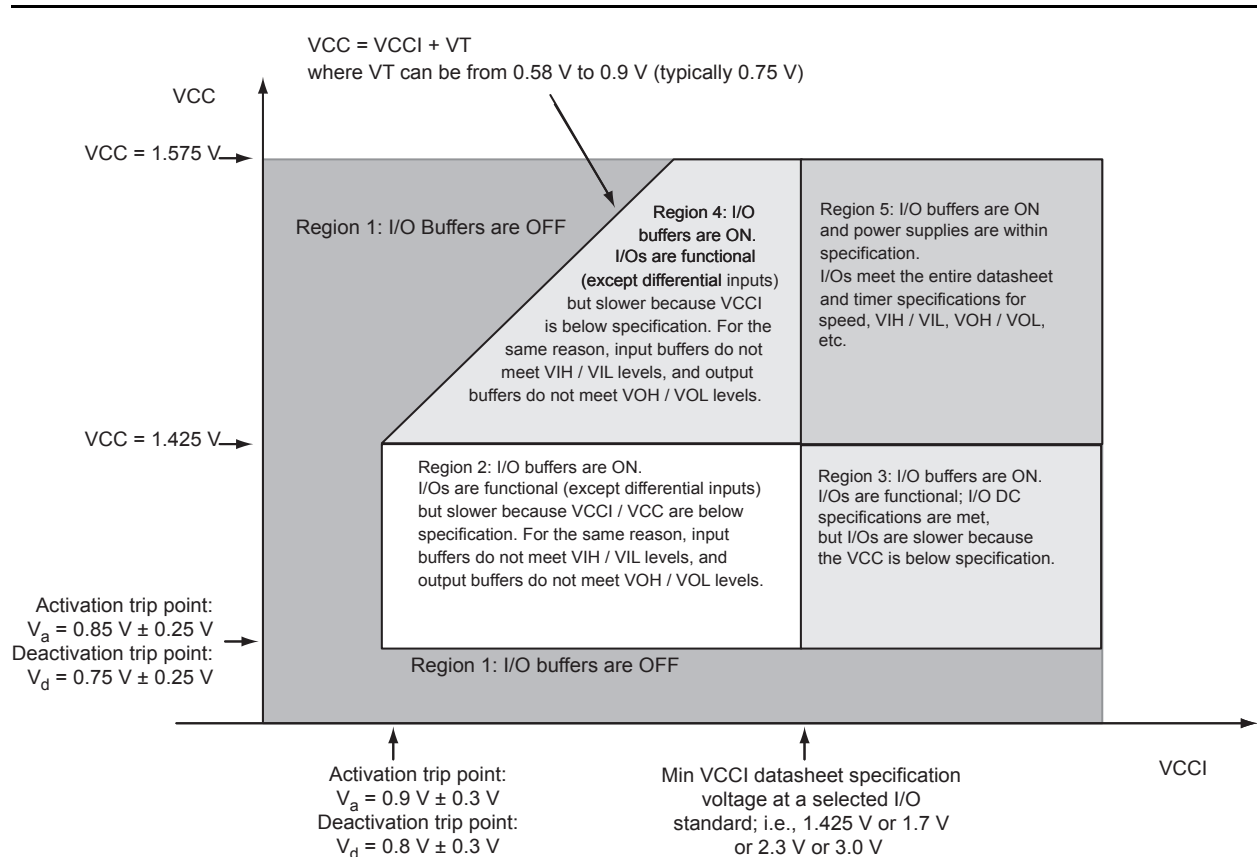

**Figure 2-1 • V5 – I/O State as a Function of VCCI and VCC Voltage Levels**

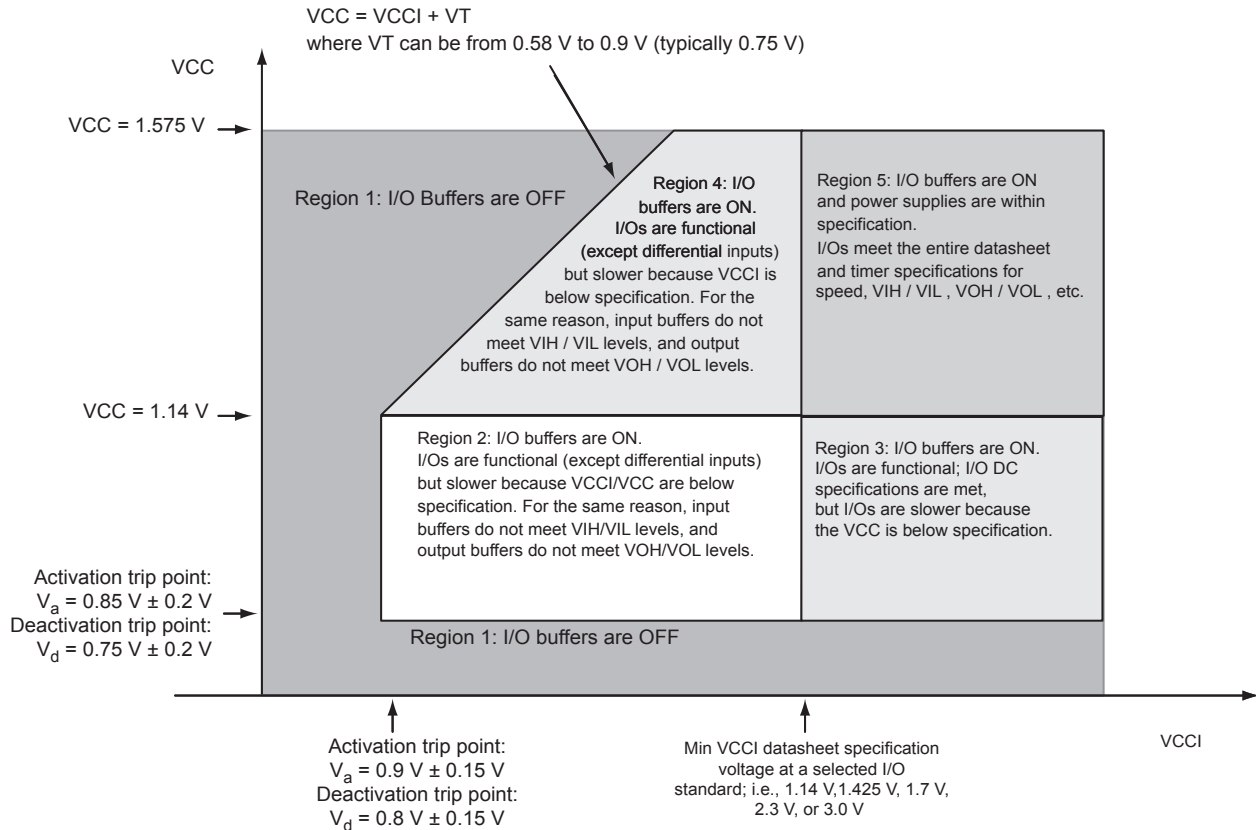

**Figure 2-2 • V2 Devices – I/O State as a Function of VCCI and VCC Voltage Levels**

## Thermal Characteristics

### Introduction

The temperature variable in Microsemi Designer software refers to the junction temperature, not the ambient temperature. This is an important distinction because dynamic and static power consumption cause the chip junction to be higher than the ambient temperature.

EQ 1 can be used to calculate junction temperature.

$$T_J = \text{Junction Temperature} = \Delta T + T_A$$

EQ 1

where:

$T_A$  = Ambient Temperature

$\Delta T$  = Temperature gradient between junction (silicon) and ambient  $\Delta T = \theta_{ja} * P$

$\theta_{ja}$  = Junction-to-ambient of the package.  $\theta_{ja}$  numbers are located in Table 2-5.

P = Power dissipation

### Package Thermal Characteristics

The device junction-to-case thermal resistivity is  $\theta_{jc}$  and the junction-to-ambient air thermal resistivity is  $\theta_{ja}$ . The thermal characteristics for  $\theta_{ja}$  are shown for two air flow rates. The absolute maximum junction temperature is 100°C. EQ 2 shows a sample calculation of the absolute maximum power dissipation allowed for an 896-pin FBGA package at commercial temperature and in still air.

$$\text{Maximum Power Allowed} = \frac{\text{Max. junction temp. (}^\circ\text{C)} - \text{Max. ambient temp. (}^\circ\text{C)}}{\theta_{ja} (^\circ\text{C/W)}} = \frac{100^\circ\text{C} - 70^\circ\text{C}}{13.6^\circ\text{C/W}} = 2.206 \text{ W}$$

EQ 2

**Table 2-5 • Package Thermal Resistivities**

Package Type	Pin Count	$\theta_{jc}$	$\theta_{ja}$			Units
			Still Air	200 ft./min.	500 ft./min.	
Plastic Quad Flat Package (PQFP)	208	8.0	26.1	22.5	20.8	C/W
Plastic Quad Flat Package (PQFP) with embedded heat spreader	208	3.8	16.2	13.3	11.9	C/W
Fine Pitch Ball Grid Array (FBGA)	256	3.8	26.9	22.8	21.5	C/W
	484	3.2	20.5	17.0	15.9	C/W
	676	3.2	16.4	13.0	12.0	C/W
	896	2.4	13.6	10.4	9.4	C/W

### Temperature and Voltage Derating Factors

**Table 2-6 • Temperature and Voltage Derating Factors for Timing Delays**  
 (normalized to  $T_J = 70^\circ\text{C}$ ,  $V_{CC} = 1.425 \text{ V}$ )  
 For IGLOOe V2 or V5 devices, 1.5 V DC Core Supply Voltage

Array Voltage VCC (V)	Junction Temperature ( $^\circ\text{C}$ )					
	-40 $^\circ\text{C}$	0 $^\circ\text{C}$	25 $^\circ\text{C}$	70 $^\circ\text{C}$	85 $^\circ\text{C}$	100 $^\circ\text{C}$
1.425	0.945	0.965	0.978	1.000	1.008	1.013
1.500	0.876	0.893	0.906	0.927	0.934	0.940
1.575	0.824	0.840	0.852	0.872	0.879	0.884

**Table 2-7 • Temperature and Voltage Derating Factors for Timing Delays**  
 (normalized to  $T_J = 70^\circ\text{C}$ ,  $V_{CC} = 1.14 \text{ V}$ )  
 For IGLOOe V2, 1.2 V DC Core Supply Voltage

Array Voltage VCC (V)	Junction Temperature ( $^\circ\text{C}$ )					
	-40 $^\circ\text{C}$	0 $^\circ\text{C}$	25 $^\circ\text{C}$	70 $^\circ\text{C}$	85 $^\circ\text{C}$	100 $^\circ\text{C}$
1.14	0.968	0.978	0.991	1.000	1.006	1.010
1.20	0.864	0.873	0.885	0.893	0.898	0.902
1.26	0.793	0.803	0.813	0.821	0.826	0.829

## Calculating Power Dissipation

### Quiescent Supply Current

Quiescent supply current (IDD) calculation depends on multiple factors, including operating voltages (VCC, VCCI, and VJTAG), operating temperature, system clock frequency, and power modes usage. Microsemi recommends using the PowerCalculator and SmartPower software estimation tools to evaluate the projected static and active power based on the user design, power mode usage, operating voltage, and temperature.

**Table 2-8 • Power Supply State per Mode**

Modes/power supplies	Power Supply Configurations				
	VCC	VCCPLL	VCCI	VJTAG	VPUMP
Flash*Freeze	On	On	On	On	On/off/floating
Sleep	Off	Off	On	Off	Off
Shutdown	Off	Off	Off	Off	Off
No Flash*Freeze	On	On	On	On	On/off/floating

*Note:* Off: Power supply level = 0 V

**Table 2-9 • Quiescent Supply Current (IDD), IGLOOe Flash\*Freeze Mode\***

	Core Voltage	AGLE600	AGLE3000	Units
Typical (25°C)	1.2 V	34	95	μA
	1.5 V	72	310	μA

*Note:* \*IDD includes VCC, VPUMP, VCCI, VCCPLL, and VMV currents. Values do not include I/O static contribution, which is shown in [Table 2-13 on page 2-9](#) and [Table 2-14 on page 2-10](#) (PDC6 and PDC7).

**Table 2-10 • Quiescent Supply Current (IDD) Characteristics, IGLOOe Sleep Mode\***

	Core Voltage	AGLE600	AGLE3000	Units
VCCI/VJTAG = 1.2 V (per bank) Typical (25°C)	1.2 V	1.7	1.7	μA
VCCI/VJTAG = 1.5 V (per bank) Typical (25°C)	1.2 V / 1.5 V	1.8	1.8	μA
VCCI/VJTAG = 1.8 V (per bank) Typical (25°C)	1.2 V / 1.5 V	1.9	1.9	μA
VCCI/VJTAG = 2.5 V (per bank) Typical (25°C)	1.2 V / 1.5 V	2.2	2.2	μA
VCCI/VJTAG = 3.3 V (per bank) Typical (25°C)	1.2 V / 1.5 V	2.5	2.5	μA

*Note:* \*IDD =  $N_{BANKS} \times ICCI$ . Values do not include I/O static contribution, which is shown in [Table 2-13 on page 2-9](#) and [Table 2-14 on page 2-10](#) (PDC6 and PDC7).

**Table 2-11 • Quiescent Supply Current (IDD) Characteristics, IGLOOe Shutdown Mode\***

	Core Voltage	AGLE600	AGLE3000	Units
Typical (25°C)	1.2 V / 1.5 V	0	0	μA

**Table 2-12 • Quiescent Supply Current (IDD) Characteristics, No Flash\*Freeze Mode<sup>1</sup>**

	Core Voltage	AGLE600	AGLE3000	Units
<b>ICCA Current<sup>2</sup></b>				
Typical (25°C)	1.2 V	28	89	μA
	1.5 V	82	320	μA
<b>ICCI or IJTAG Current<sup>3</sup></b>				
VCCI/VJTAG = 1.2 V (per bank) Typical (25°C)	1.2 V	1.7	1.7	μA
VCCI/VJTAG = 1.5 V (per bank) Typical (25°C)	1.2 V / 1.5 V	1.8	1.8	μA
VCCI/VJTAG = 1.8 V (per bank) Typical (25°C)	1.2 V / 1.5 V	1.9	1.9	μA
VCCI/VJTAG = 2.5 V (per bank) Typical (25°C)	1.2 V / 1.5 V	2.2	2.2	μA
VCCI/VJTAG= 3.3 V (per bank) Typical (25°C)	1.2 V / 1.5 V	2.5	2.5	μA

**Notes:**

1.  $IDD = N_{BANKS} \times ICCI + ICCA$ . JTAG counts as one bank when powered.
2. Includes VCC and VPUMP and VCCPLL currents.
3. Values do not include I/O static contribution (PDC6 and PDC7).

## Power per I/O Pin

**Table 2-13 • Summary of I/O Input Buffer Power (per pin) – Default I/O Software Settings**

	VCCI (V)	Static Power PDC6 (mW) <sup>1</sup>	Dynamic Power PAC9 (µW/MHz) <sup>2</sup>
<b>Single-Ended</b>			
3.3 V LVTTTL/LVCMOS	3.3	–	16.34
3.3 V LVTTTL/LVCMOS – Schmitt trigger	3.3	–	24.49
3.3 V LVCMOS Wide Range <sup>3</sup>	3.3	–	16.34
3.3 V LVCMOS Wide Range – Schmitt trigger <sup>3</sup>	3.3	–	24.49
2.5 V LVCMOS	2.5	–	4.71
2.5 V LVCMOS	2.5	–	6.13
1.8 V LVCMOS	1.8	–	1.66
1.8 V LVCMOS – Schmitt trigger	1.8	–	1.78
1.5 V LVCMOS (JESD8-11)	1.5	–	1.01
1.5 V LVCMOS (JESD8-11) – Schmitt trigger	1.5	–	0.97
1.2 V LVCMOS <sup>4</sup>	1.2	–	0.60
1.2 V LVCMOS – Schmitt trigger <sup>4</sup>	1.2	–	0.53
1.2 V LVCMOS Wide Range <sup>4</sup>	1.2	–	0.60
1.2 V LVCMOS Wide Range – Schmitt trigger <sup>4</sup>	1.2	–	0.53
3.3 V PCI	3.3	–	17.76
3.3 V PCI – Schmitt trigger	3.3	–	19.10
3.3 V PCI-X	3.3	–	17.76
3.3 V PCI-X – Schmitt trigger	3.3	–	19.10
<b>Voltage-Referenced</b>			
3.3 V GTL	3.3	2.90	7.14
2.5 V GTL	2.5	2.13	3.54
3.3 V GTL+	3.3	2.81	2.91
2.5 V GTL+	2.5	2.57	2.61
HSTL (I)	1.5	0.17	0.79
HSTL (II)	1.5	0.17	.079
SSTL2 (I)	2.5	1.38	3.26
SSTL2 (II)	2.5	1.38	3.26
SSTL3 (I)	3.3	3.21	7.97
SSTL3 (II)	3.3	3.21	7.97
<b>Differential</b>			
LVDS	2.5	2.26	0.89
LVPECL	3.3	5.71	1.94

**Notes:**

1. PDC6 is the static power (where applicable) measured on VCCI.
2. PAC9 is the total dynamic power measured on VCCI.
3. All LVCMOS 3.3 V software macros support LVCMOS 3.3 V wide range as specified in the JESD8b specification.
4. Applicable for IGLOOe V2 devices only.

**Table 2-14 • Summary of I/O Output Buffer Power (per pin) – Default I/O Software Settings<sup>1</sup>**

	C <sub>LOAD</sub> (pF)	V <sub>CCI</sub> (V)	Static Power PDC7 (mW) <sup>2</sup>	Dynamic Power PAC10 (μW/MHz) <sup>3</sup>
<b>Single-Ended</b>				
3.3 V LVTTTL/LVCMOS	5	3.3	–	148.00
3.3 V LVCMOS Wide Range <sup>4</sup>	5	3.3	–	148.00
2.5 V LVCMOS	5	2.5	–	83.23
1.8 V LVCMOS	5	1.8	–	54.58
1.5 V LVCMOS (JESD8-11)	5	1.5	–	37.05
1.2 V LVCMOS (JESD8-11)	5	1.2	–	17.94
1.2 V LVCMOS (JESD8-11) – Wide Range				17.94
3.3 V PCI	10	3.3	–	204.61
3.3 V PCI-X	10	3.3	–	204.61
<b>Voltage-Referenced</b>				
3.3 V GTL	10	3.3	–	24.08
2.5 V GTL	10	2.5	–	13.52
3.3 V GTL+	10	3.3	–	24.10
2.5 V GTL+	10	2.5	–	13.54
HSTL (I)	20	1.5	7.08	26.22
HSTL (II)	20	1.5	13.88	27.18
SSTL2 (I)	30	2.5	16.69	105.56
SSTL2 (II)	30	2.5	25.91	116.60
SSTL3 (I)	30	3.3	26.02	114.67
SSTL3 (II)	30	3.3	42.21	131.69
<b>Differential</b>				
LVDS	–	2.5	7.70	89.62
LVPECL	–	3.3	19.42	167.86

**Notes:**

1. Dynamic power consumption is given for standard load and software default drive strength and output slew.
2. PDC7 is the static power (where applicable) measured on VCCI.
3. PAC10 is the total dynamic power measured on VCCI.
4. All LVCMOS 3.3 V software macros support LVCMOS 3.3 V wide range as specified in the JESD8b specification.

## Power Consumption of Various Internal Resources

**Table 2-15 • Different Components Contributing to the Dynamic Power Consumption in IGLOOe Devices For IGLOOe V2 or V5 Devices, 1.5 V DC Core Supply Voltage**

Parameter	Definition	Device-Specific Dynamic Contributions ( $\mu\text{W}/\text{MHz}$ )	
		AGLE600	AGLE3000
PAC1	Clock contribution of a Global Rib	19.7	12.77
PAC2	Clock contribution of a Global Spine	4.16	1.85
PAC3	Clock contribution of a VersaTile row	0.88	
PAC4	Clock contribution of a VersaTile used as a sequential module	0.11	
PAC5	First contribution of a VersaTile used as a sequential module	0.057	
PAC6	Second contribution of a VersaTile used as a sequential module	0.207	
PAC7	Contribution of a VersaTile used as a combinatorial module	0.207	
PAC8	Average contribution of a routing net	0.7	
PAC9	Contribution of an I/O input pin (standard-dependent)	See <a href="#">Table 2-13 on page 2-9</a> .	
PAC10	Contribution of an I/O output pin (standard-dependent)	See <a href="#">Table 2-14 on page 2-10</a> .	
PAC11	Average contribution of a RAM block during a read operation	25.00	
PAC12	Average contribution of a RAM block during a write operation	30.00	
PAC13	Dynamic contribution for PLL	2.70	

*Note:* For a different output load, drive strength, or slew rate, Microsemi recommends using the Microsemi power calculator or SmartPower in Libero SoC software.

**Table 2-16 • Different Components Contributing to the Static Power Consumption in IGLOO Devices For IGLOOe V2 or V5 Devices, 1.5 V DC Core Supply Voltage**

Parameter	Definition	Device Specific Static Power (mW)	
		AGLE600	AGLE3000
PDC1	Array static power in Active mode	See <a href="#">Table 2-12 on page 2-8</a> .	
PDC2	Array static power in Static (Idle) mode	See <a href="#">Table 2-11 on page 2-7</a> .	
PDC3	Array static power in Flash*Freeze mode	See <a href="#">Table 2-9 on page 2-7</a> .	
PDC4	Static PLL contribution	1.84	
PDC5	Bank quiescent power (VCCI-dependent)	See <a href="#">Table 2-12 on page 2-8</a> .	
PDC6	I/O input pin static power (standard-dependent)	See <a href="#">Table 2-13 on page 2-9</a> .	
PDC7	I/O output pin static power (standard-dependent)	See <a href="#">Table 2-14 on page 2-10</a> .	

**Table 2-17 • Different Components Contributing to the Dynamic Power Consumption in IGLOOe Devices For IGLOOe V2 Devices, 1.2 V DC Core Supply Voltage**

Parameter	Definition	Device-Specific Dynamic Contributions ( $\mu\text{W}/\text{MHz}$ )	
		AGLE600	AGLE3000
PAC1	Clock contribution of a Global Rib	12.61	8.17
PAC2	Clock contribution of a Global Spine	2.66	1.18
PAC3	Clock contribution of a VersaTile row	0.56	
PAC4	Clock contribution of a VersaTile used as a sequential module	0.071	
PAC5	First contribution of a VersaTile used as a sequential module	0.045	
PAC6	Second contribution of a VersaTile used as a sequential module	0.186	
PAC7	Contribution of a VersaTile used as a combinatorial module	0.109	
PAC8	Average contribution of a routing net	0.449	
PAC9	Contribution of an I/O input pin (standard-dependent)	See Table 2-9 on page 2-7.	
PAC10	Contribution of an I/O output pin (standard-dependent)	See Table 2-10 on page 2-7 and Table 2-11 on page 2-7.	
PAC11	Average contribution of a RAM block during a read operation	25.00	
PAC12	Average contribution of a RAM block during a write operation	30.00	
PAC13	Dynamic PLL contribution	2.10	

*Note:* For a different output load, drive strength, or slew rate, Microsemi recommends using the Microsemi power calculator or SmartPower in Libero SoC software.

**Table 2-18 • Different Components Contributing to the Static Power Consumption in IGLOO Devices For IGLOOe V2 Devices, 1.2 V DC Core Supply Voltage**

Parameter	Definition	Device Specific Static Power (mW)	
		AGLE600	AGLE3000
PDC1	Array static power in Active mode	See Table 2-12 on page 2-8.	
PDC2	Array static power in Static (Idle) mode	See Table 2-11 on page 2-7.	
PDC3	Array static power in Flash*Freeze mode	See Table 2-9 on page 2-7.	
PDC4	Static PLL contribution	0.90	
PDC5	Bank quiescent power (VCCI-dependent)	See Table 2-12 on page 2-8.	
PDC6	I/O input pin static power (standard-dependent)	See Table 2-13 on page 2-9.	
PDC7	I/O output pin static power (standard-dependent)	See Table 2-14 on page 2-10.	

## Power Calculation Methodology

This section describes a simplified method to estimate power consumption of an application. For more accurate and detailed power estimations, use the SmartPower tool in the Libero SoC software.

The power calculation methodology described below uses the following variables:

- The number of PLLs as well as the number and the frequency of each output clock generated
- The number of combinatorial and sequential cells used in the design
- The internal clock frequencies
- The number and the standard of I/O pins used in the design
- The number of RAM blocks used in the design
- Toggle rates of I/O pins as well as VersaTiles—guidelines are provided in [Table 2-19 on page 2-15](#).
- Enable rates of output buffers—guidelines are provided for typical applications in [Table 2-20 on page 2-15](#).
- Read rate and write rate to the memory—guidelines are provided for typical applications in [Table 2-20 on page 2-15](#). The calculation should be repeated for each clock domain defined in the design.

### Methodology

#### Total Power Consumption— $P_{TOTAL}$

$$P_{TOTAL} = P_{STAT} + P_{DYN}$$

$P_{STAT}$  is the total static power consumption.

$P_{DYN}$  is the total dynamic power consumption.

#### Total Static Power Consumption— $P_{STAT}$

$$P_{STAT} = (PDC1 \text{ or } PDC2 \text{ or } PDC3) + N_{BANKS} * PDC5 + N_{INPUTS} * PDC6 + N_{OUTPUTS} * PDC7$$

$N_{INPUTS}$  is the number of I/O input buffers used in the design.

$N_{OUTPUTS}$  is the number of I/O output buffers used in the design.

$N_{BANKS}$  is the number of I/O banks powered in the design.

#### Total Dynamic Power Consumption— $P_{DYN}$

$$P_{DYN} = P_{CLOCK} + P_{S-CELL} + P_{C-CELL} + P_{NET} + P_{INPUTS} + P_{OUTPUTS} + P_{MEMORY} + P_{PLL}$$

#### Global Clock Contribution— $P_{CLOCK}$

$$P_{CLOCK} = (PAC1 + N_{SPINE} * PAC2 + N_{ROW} * PAC3 + N_{S-CELL} * PAC4) * F_{CLK}$$

$N_{SPINE}$  is the number of global spines used in the user design—guidelines are provided in the "Spine Architecture" section of the Global Resources chapter in the *IGLOOe FPGA Fabric User's Guide*.

$N_{ROW}$  is the number of VersaTile rows used in the design—guidelines are provided in the "Spine Architecture" section of the Global Resources chapter in the *IGLOOe FPGA Fabric User's Guide*.

$F_{CLK}$  is the global clock signal frequency.

$N_{S-CELL}$  is the number of VersaTiles used as sequential modules in the design.

PAC1, PAC2, PAC3, and PAC4 are device-dependent.

#### Sequential Cells Contribution— $P_{S-CELL}$

$$P_{S-CELL} = N_{S-CELL} * (PAC5 + \alpha_1 / 2 * PAC6) * F_{CLK}$$

$N_{S-CELL}$  is the number of VersaTiles used as sequential modules in the design. When a multi-tile sequential cell is used, it should be accounted for as 1.

$\alpha_1$  is the toggle rate of VersaTile outputs—guidelines are provided in [Table 2-19 on page 2-15](#).

$F_{CLK}$  is the global clock signal frequency.

### Combinatorial Cells Contribution— $P_{C-CELL}$

$$P_{C-CELL} = N_{C-CELL} * \alpha_1 / 2 * PAC7 * F_{CLK}$$

$N_{C-CELL}$  is the number of VersaTiles used as combinatorial modules in the design.

$\alpha_1$  is the toggle rate of VersaTile outputs—guidelines are provided in [Table 2-19](#) on page 2-15.

$F_{CLK}$  is the global clock signal frequency.

### Routing Net Contribution— $P_{NET}$

$$P_{NET} = (N_{S-CELL} + N_{C-CELL}) * \alpha_1 / 2 * PAC8 * F_{CLK}$$

$N_{S-CELL}$  is the number of VersaTiles used as sequential modules in the design.

$N_{C-CELL}$  is the number of VersaTiles used as combinatorial modules in the design.

$\alpha_1$  is the toggle rate of VersaTile outputs—guidelines are provided in [Table 2-19](#) on page 2-15.

$F_{CLK}$  is the global clock signal frequency.

### I/O Input Buffer Contribution— $P_{INPUTS}$

$$P_{INPUTS} = N_{INPUTS} * \alpha_2 / 2 * PAC9 * F_{CLK}$$

$N_{INPUTS}$  is the number of I/O input buffers used in the design.

$\alpha_2$  is the I/O buffer toggle rate—guidelines are provided in [Table 2-19](#) on page 2-15.

$F_{CLK}$  is the global clock signal frequency.

### I/O Output Buffer Contribution— $P_{OUTPUTS}$

$$P_{OUTPUTS} = N_{OUTPUTS} * \alpha_2 / 2 * \beta_1 * PAC10 * F_{CLK}$$

$N_{OUTPUTS}$  is the number of I/O output buffers used in the design.

$\alpha_2$  is the I/O buffer toggle rate—guidelines are provided in [Table 2-19](#) on page 2-15.

$\beta_1$  is the I/O buffer enable rate—guidelines are provided in [Table 2-20](#) on page 2-15.

$F_{CLK}$  is the global clock signal frequency.

### RAM Contribution— $P_{MEMORY}$

$$P_{MEMORY} = PAC11 * N_{BLOCKS} * F_{READ-CLOCK} * \beta_2 + PAC12 * N_{BLOCK} * F_{WRITE-CLOCK} * \beta_3$$

$N_{BLOCKS}$  is the number of RAM blocks used in the design.

$F_{READ-CLOCK}$  is the memory read clock frequency.

$\beta_2$  is the RAM enable rate for read operations—guidelines are provided in [Table 2-20](#) on page 2-15.

$F_{WRITE-CLOCK}$  is the memory write clock frequency.

$\beta_3$  is the RAM enable rate for write operations—guidelines are provided in [Table 2-20](#) on page 2-15.

### PLL Contribution— $P_{PLL}$

$$P_{PLL} = PDC4 + PAC13 * F_{CLKOUT}$$

$F_{CLKOUT}$  is the output clock frequency.<sup>1</sup>

---

1. If a PLL is used to generate more than one output clock, include each output clock in the formula by adding its corresponding contribution ( $PAC13 * F_{CLKOUT}$  product) to the total PLL contribution.

## Guidelines

### Toggle Rate Definition

A toggle rate defines the frequency of a net or logic element relative to a clock. It is a percentage. If the toggle rate of a net is 100%, this means that this net switches at half the clock frequency. Below are some examples:

- The average toggle rate of a shift register is 100% as all flip-flop outputs toggle at half of the clock frequency.
- The average toggle rate of an 8-bit counter is 25%:
  - Bit 0 (LSB) = 100%
  - Bit 1 = 50%
  - Bit 2 = 25%
  - ...
  - Bit 7 (MSB) = 0.78125%
  - Average toggle rate =  $(100\% + 50\% + 25\% + 12.5\% + \dots + 0.78125\%) / 8$

### Enable Rate Definition

Output enable rate is the average percentage of time during which tristate outputs are enabled. When nontristate output buffers are used, the enable rate should be 100%.

**Table 2-19 • Toggle Rate Guidelines Recommended for Power Calculation**

Component	Definition	Guideline
$\alpha_1$	Toggle rate of VersaTile outputs	10%
$\alpha_2$	I/O buffer toggle rate	10%

**Table 2-20 • Enable Rate Guidelines Recommended for Power Calculation**

Component	Definition	Guideline
$\beta_1$	I/O output buffer enable rate	100%
$\beta_2$	RAM enable rate for read operations	12.5%
$\beta_3$	RAM enable rate for write operations	12.5%

# User I/O Characteristics

## Timing Model

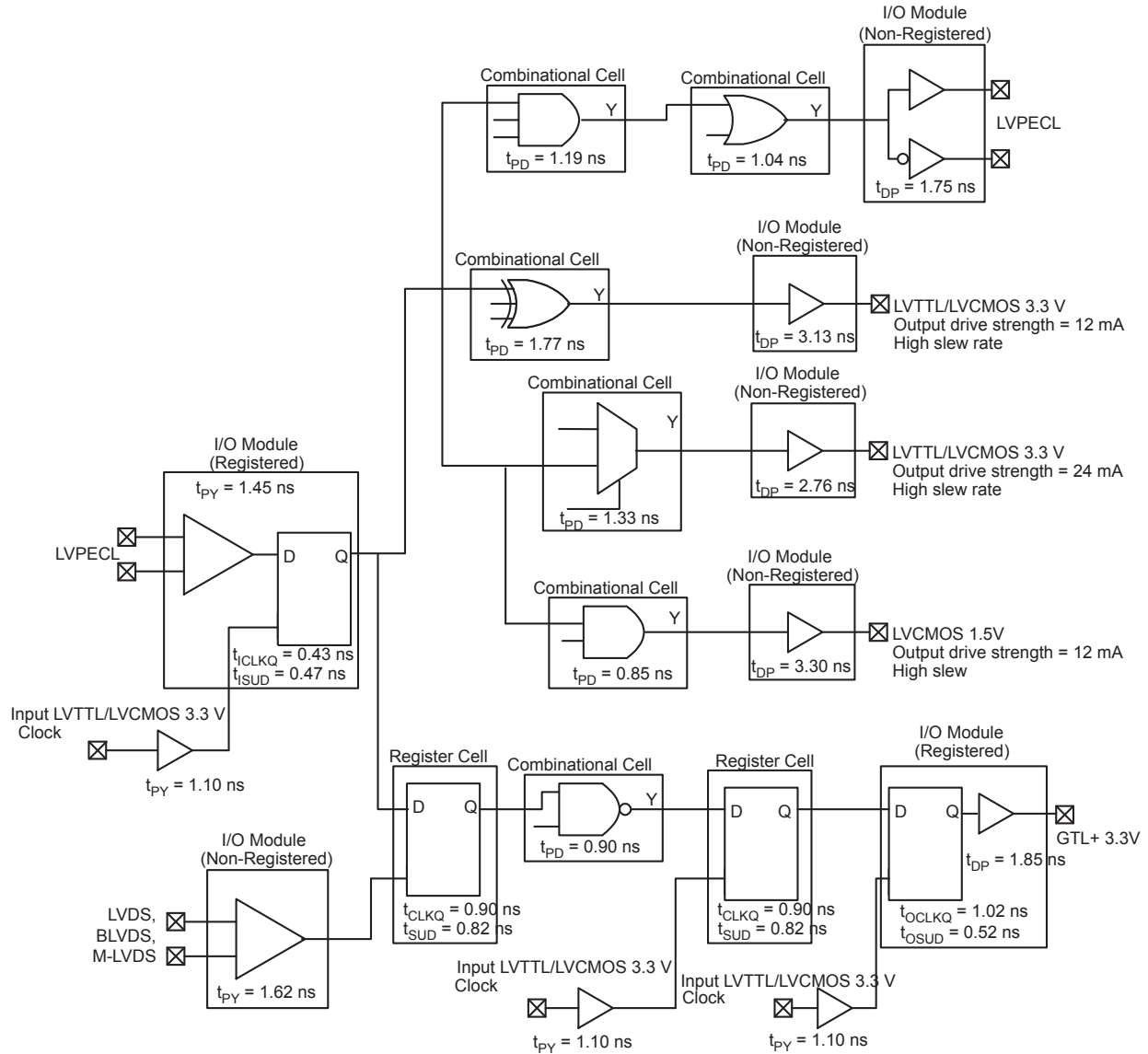

**Figure 2-3 • Timing Model**  
Operating Conditions: Std. Speed, Commercial Temperature Range ( $T_J = 70^\circ\text{C}$ ), Worst-Case VCC = 1.425 V, Applicable to 1.5 V DC Core Voltage, V2 and V5 devices

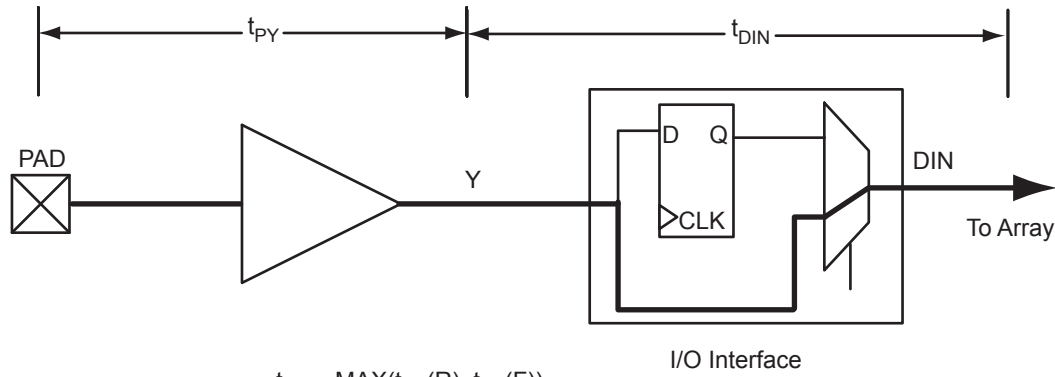

$$t_{PY} = \text{MAX}(t_{PY}(R), t_{PY}(F))$$

$$t_{DIN} = \text{MAX}(t_{DIN}(R), t_{DIN}(F))$$

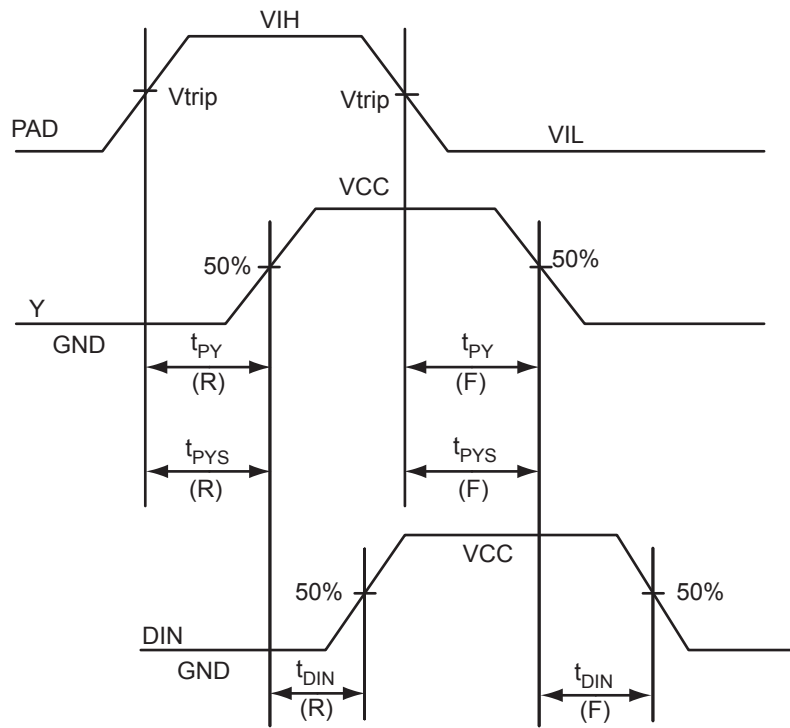

Figure 2-4 • Input Buffer Timing Model and Delays (example)

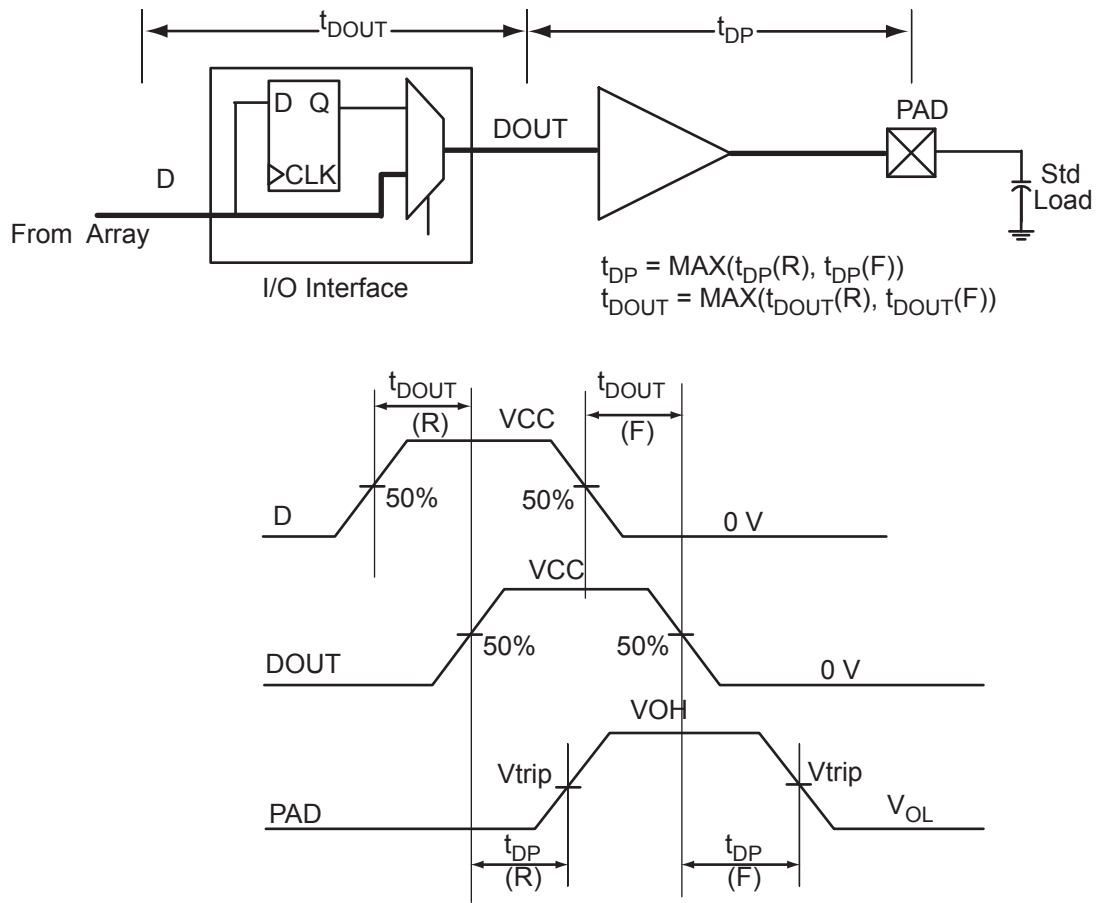

Figure 2-5 • Output Buffer Model and Delays (example)

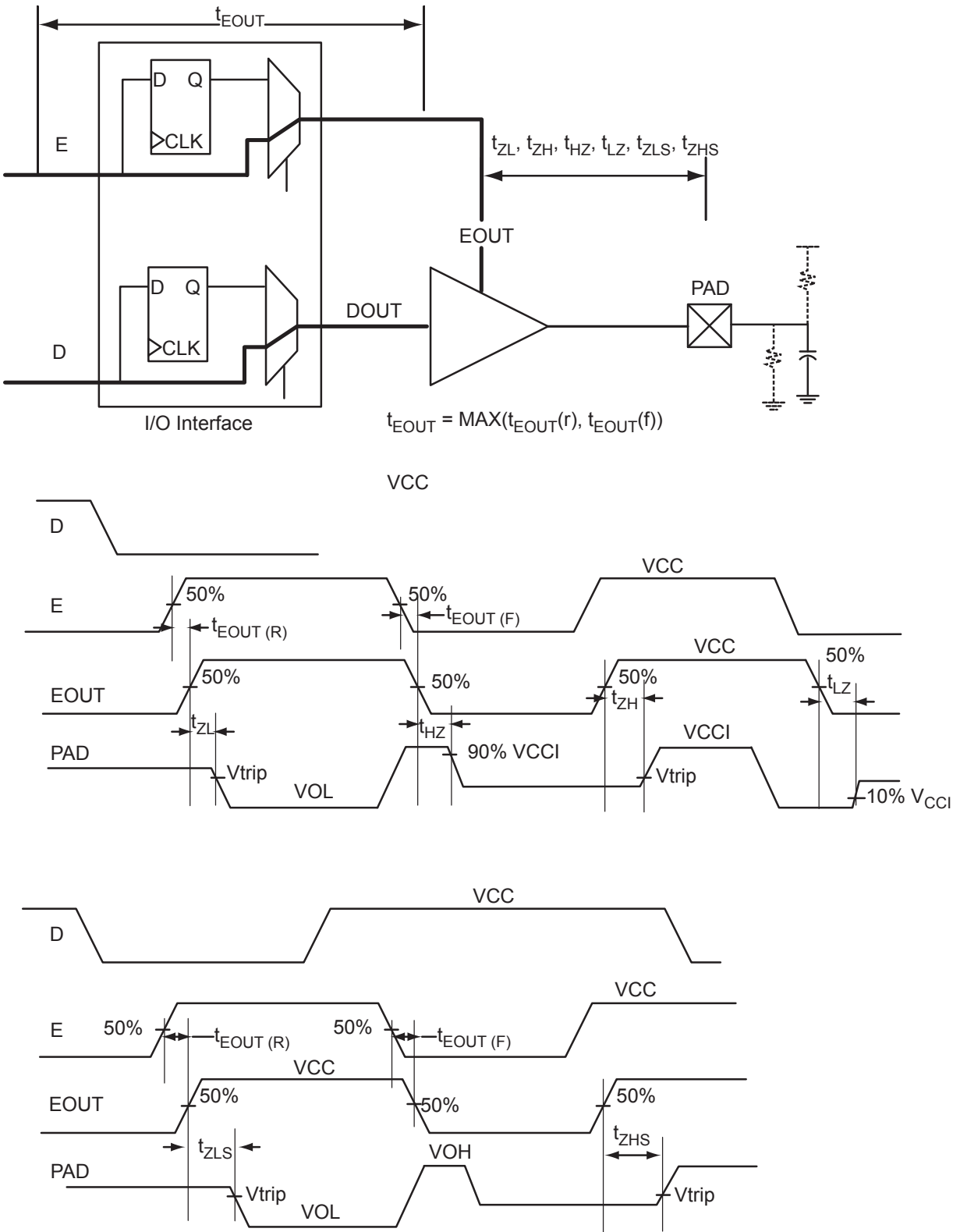

Figure 2-6 • Tristate Output Buffer Timing Model and Delays (example)

## Overview of I/O Performance

### Summary of I/O DC Input and Output Levels – Default I/O Software Settings

**Table 2-21 • Summary of Maximum and Minimum DC Input and Output Levels**  
 Applicable to Commercial and Industrial Conditions

I/O Standard	Drive Strength	Equivalent Software Default Drive Strength <sup>2</sup>	Slew Rate	VIL		VIH		VOL	VOH	IOL <sup>1</sup>	IOH <sup>1</sup>
				Min. V	Max. V	Min. V	Max. V	Max. V	Min. V	mA	mA
3.3 V LVTTTL / 3.3 V LVCMOS	12 mA	12 mA	High	-0.3	0.8	2	3.6	0.4	2.4	12	12
3.3 V LVCMOS Wide Range <sup>3</sup>	100 $\mu$ A	12 mA	High	-0.3	0.8	2	3.6	0.2	VCCI - 0.2	0.1	0.1
2.5 V LVCMOS	12 mA	12 mA	High	-0.3	0.7	1.7	3.6	0.7	1.7	12	12
1.8 V LVCMOS	12 mA	12 mA	High	-0.3	0.35 * VCCI	0.65 * VCCI	3.6	0.45	VCCI - 0.45	12	12
1.5 V LVCMOS	12 mA	12 mA	High	-0.3	0.35 * VCCI	0.65 * VCCI	3.6	0.25 * VCCI	0.75 * VCCI	12	12
1.2 V LVCMOS	2 mA	2 mA	High	-0.3	0.35 * VCCI	0.65 * VCCI	3.6	0.25 * VCCI	0.75 * VCCI	2	2
1.2 V LVCMOS Wide Range <sup>4</sup>	100 $\mu$ A	2 mA	High	-0.3	0.3 * VCCI	0.7 * VCCI	3.6	0.1	VCCI - 0.1	0.1	0.1
3.3 V PCI	Per PCI Specification										
3.3 V PCI-X	Per PCI-X Specification										
3.3 V GTL	20 mA <sup>5</sup>	20 mA <sup>5</sup>	High	-0.3	VREF - 0.05	VREF + 0.05	3.6	0.4	-	20	20
2.5 V GTL	20 mA <sup>5</sup>	20 mA <sup>5</sup>	High	-0.3	VREF - 0.05	VREF + 0.05	3.6	0.4	-	20	20
3.3 V GTL+	35 mA	35 mA	High	-0.3	VREF - 0.1	VREF + 0.1	3.6	0.6	-	35	35
2.5 V GTL+	33 mA	33 mA	High	-0.3	VREF - 0.1	VREF + 0.1	3.6	0.6	-	33	33
HSTL (I)	8 mA	8 mA	High	-0.3	VREF - 0.1	VREF + 0.1	3.6	0.4	VCCI - 0.4	8	8

**Notes:**

1. Currents are measured at 85°C junction temperature.
2. The minimum drive strength for any LVCMOS 1.2 V or LVCMOS 3.3 V software configuration when run in wide range is  $\pm 100 \mu$ A. Drive strength displayed in the software is supported for normal range only. For a detailed I/V curve, refer to the IBIS models.
3. All LVCMOS 3.3 V software macros support LVCMOS 3.3 V wide range as specified in the JESD8-12 specification.
4. All LVCMOS 1.2 V software macros support LVCMOS 1.2 V wide range as specified in the JESD8-12 specification.
5. Output drive strength is below JEDEC specification.
6. Output Slew Rates can be extracted from IBIS Models, <http://www.microsemi.com/soc/download/ibis/default.aspx>.

**Table 2-21 • Summary of Maximum and Minimum DC Input and Output Levels (continued)**  
**Applicable to Commercial and Industrial Conditions**

I/O Standard	Drive Strength	Equivalent Software Default Drive Strength <sup>2</sup>	Slew Rate	VIL		VIH		VOL	VOH	IOL <sup>1</sup>	IOH <sup>1</sup>
				Min. V	Max. V	Min. V	Max. V	Max. V	Min. V	mA	mA
HSTL (II)	15 mA <sup>5</sup>	15 mA <sup>5</sup>	High	-0.3	VREF - 0.1	VREF + 0.1	3.6	0.4	VCCI - 0.4	15	15
SSTL2 (I)	15 mA	15 mA	High	-0.3	VREF - 0.2	VREF + 0.2	3.6	0.54	VCCI - 0.62	15	15
SSTL2 (II)	18 mA	18 mA	High	-0.3	VREF - 0.2	VREF + 0.2	3.6	0.35	VCCI - 0.43	18	18
SSTL3 (I)	14 mA	14 mA	High	-0.3	VREF - 0.2	VREF + 0.2	3.6	0.7	VCCI - 1.1	14	14
SSTL3 (II)	21 mA	21 mA	High	-0.3	VREF - 0.2	VREF + 0.2	3.6	0.5	VCCI - 0.9	21	21

**Notes:**

1. Currents are measured at 85°C junction temperature.
2. The minimum drive strength for any LVCMOS 1.2 V or LVCMOS 3.3 V software configuration when run in wide range is  $\pm 100 \mu\text{A}$ . Drive strength displayed in the software is supported for normal range only. For a detailed I/V curve, refer to the IBIS models.
3. All LVCMOS 3.3 V software macros support LVCMOS 3.3 V wide range as specified in the JESD8-12 specification.
4. All LVCMOS 1.2 V software macros support LVCMOS 1.2 V wide range as specified in the JESD8-12 specification.
5. Output drive strength is below JEDEC specification.
6. Output Slew Rates can be extracted from IBIS Models, <http://www.microsemi.com/soc/download/ibis/default.aspx>.

**Table 2-22 • Summary of Maximum and Minimum DC Input Levels  
Applicable to Commercial and Industrial Conditions**

DC I/O Standards	Commercial <sup>1</sup>		Industrial <sup>2</sup>	
	IIL <sup>3</sup>	IIH <sup>4</sup>	IIL <sup>3</sup>	IIH <sup>4</sup>
	μA	μA	μA	μA
3.3 V LVTTTL / 3.3 V LVCMOS	10	10	15	15
3.3 V LVCMOS Wide Range	10	10	15	15
2.5 V LVCMOS	10	10	15	15
1.8 V LVCMOS	10	10	15	15
1.5 V LVCMOS	10	10	15	15
1.2 V LVCMOS <sup>5</sup>	10	10	15	15
1.2 V LVCOMS Wide Range <sup>5</sup>	10	10	15	15
3.3 V PCI	10	10	15	15
3.3 V PCI-X	10	10	15	15
3.3 V GTL	10	10	15	15
2.5 V GTL	10	10	15	15
3.3 V GTL+	10	10	15	15
2.5 V GTL+	10	10	15	15
HSTL (I)	10	10	15	15
HSTL (II)	10	10	15	15
SSTL2 (I)	10	10	15	15
SSTL2 (II)	10	10	15	15
SSTL3 (I)	10	10	15	15
SSTL3 (II)	10	10	15	15

**Notes:**

1. Commercial range ( $0^{\circ}\text{C} < T_A < 70^{\circ}\text{C}$ )
2. Industrial range ( $-40^{\circ}\text{C} < T_A < 85^{\circ}\text{C}$ )
3. IIL is the input leakage current per I/O pin over recommended operation conditions where  $-0.3\text{ V} < V_{IN} < V_{IL}$ .
4. IIH is the input leakage current per I/O pin over recommended operating conditions  $V_{IH} < V_{IN} < V_{CCI}$ . Input current is larger when operating outside recommended ranges.
5. Applicable to V2 devices operating at  $V_{CCI} \geq V_{CC}$ .

## Summary of I/O Timing Characteristics – Default I/O Software Settings

Table 2-23 • Summary of AC Measuring Points

Standard	Input Reference Voltage (VREF_TYP)	Board Termination Voltage (VTT_REF)	Measuring Trip Point (Vtrip)
3.3 V LVTTTL / 3.3 V LVCMOS	–	–	1.4 V
3.3 V LVCMOS Wide Range	–	–	1.4 V
2.5 V LVCMOS	–	–	1.2 V
1.8 V LVCMOS	–	–	0.90 V
1.5 V LVCMOS	–	–	0.75 V
1.2 V LVCMOS*	–	–	0.6 V
1.2 V LVCMOS – Wide Range*	–	–	0.6 V
3.3 V PCI	–	–	0.285 * VCCI (RR)
	–	–	0.615 * VCCI (FF))
3.3 V PCI-X	–	–	0.285 * VCCI (RR)
	–	–	0.615 * VCCI (FF)
3.3 V GTL	0.8 V	1.2 V	VREF
2.5 V GTL	0.8 V	1.2 V	VREF
3.3 V GTL+	1.0 V	1.5 V	VREF
2.5 V GTL+	1.0 V	1.5 V	VREF
HSTL (I)	0.75 V	0.75 V	VREF
HSTL (II)	0.75 V	0.75 V	VREF
SSTL2 (I)	1.25 V	1.25 V	VREF
SSTL2 (II)	1.25 V	1.25 V	VREF
SSTL3 (I)	1.5 V	1.485 V	VREF
SSTL3 (II)	1.5 V	1.485 V	VREF
LVDS	–	–	Cross point
LVPECL	–	–	Cross point

Note: \*Applicable to V2 devices ONLY operating in the 1.2 V core range.

**Table 2-24 • I/O AC Parameter Definitions**

<b>Parameter</b>	<b>Definition</b>
$t_{DP}$	Data to Pad delay through the Output Buffer
$t_{PY}$	Pad to Data delay through the Input Buffer with Schmitt trigger disabled
$t_{DOUT}$	Data to Output Buffer delay through the I/O interface
$t_{EOUT}$	Enable to Output Buffer Tristate Control delay through the I/O interface
$t_{DIN}$	Input Buffer to Data delay through the I/O interface
$t_{PYS}$	Pad to Data delay through the Input Buffer with Schmitt trigger enabled
$t_{HZ}$	Enable to Pad delay through the Output Buffer—HIGH to Z
$t_{ZH}$	Enable to Pad delay through the Output Buffer—Z to HIGH
$t_{LZ}$	Enable to Pad delay through the Output Buffer—LOW to Z
$t_{ZL}$	Enable to Pad delay through the Output Buffer—Z to LOW
$t_{ZHS}$	Enable to Pad delay through the Output Buffer with delayed enable—Z to HIGH
$t_{ZLS}$	Enable to Pad delay through the Output Buffer with delayed enable—Z to LOW

**Table 2-25 • Summary of I/O Timing Characteristics—Software Default Settings**  
 Std. Speed Grade, Commercial-Case Conditions:  $T_J = 70^\circ\text{C}$ , Worst-Case  $V_{CC} = 1.425\text{ V}$ ,  
 Worst-Case  $V_{CCI}$  (per standard)

I/O Standard	Drive Strength (mA)	Equivalent Software Default Drive Strength Option <sup>1</sup> (mA)	Slew Rate	Capacitive Load (pF)	External Resistor ( $\Omega$ )	$t_{DOUT}$ (ns)	$t_{DP}$ (ns)	$t_{DIN}$ (ns)	$t_{PY}$ (ns)	$t_{PYS}$ (ns)	$t_{EOUT}$ (ns)	$t_{ZL}$ (ns)	$t_{ZH}$ (ns)	$t_{LZ}$ (ns)	$t_{HZ}$ (ns)	$t_{ZLS}$ (ns)	$t_{ZHS}$ (ns)	Units
3.3 V LVTTTL / 3.3 V LVCMOS	12	12	High	5	–	0.97	2.12	0.18	1.08	1.34	0.66	2.17	1.69	2.71	3.08	5.76	5.28	ns
3.3 V LVCMOS Wide Range <sup>1, 2</sup>	100 $\mu\text{A}$	12	High	5	–	0.97	2.96	0.18	1.42	1.84	0.66	2.98	2.28	3.86	4.36	6.58	5.87	ns
2.5 V LVCMOS	12	12	High	5	–	0.97	2.15	0.18	1.31	1.41	0.66	2.20	1.85	2.78	2.98	5.80	5.45	ns
1.8 V LVCMOS	12	12	High	5	–	0.97	2.37	0.18	1.27	1.59	0.66	2.42	2.03	3.07	3.57	6.02	5.62	ns
1.5 V LVCMOS	12	12	High	5	–	0.97	2.69	0.18	1.47	1.77	0.66	2.75	2.30	3.24	3.67	6.35	5.89	ns
3.3 V PCI	Per PCI spec	–	High	10	25 <sup>3</sup>	0.97	2.38	0.18	0.96	1.42	0.66	2.43	1.80	2.72	3.08	6.03	5.39	ns
3.3 V PCI-X	Per PCI-X spec	–	High	10	25 <sup>3</sup>	0.97	2.38	0.19	0.92	1.34	0.66	2.43	1.80	2.72	3.08	6.03	5.39	ns
3.3 V GTL	20 <sup>4</sup>	–	High	10	25	0.97	1.78	0.19	2.35	–	0.66	1.80	1.78	–	–	5.39	5.38	ns
2.5 V GTL	20 <sup>4</sup>	–	High	10	25	0.97	1.85	0.19	1.98	–	0.66	1.89	1.82	–	–	5.49	5.42	ns
3.3 V GTL+	35	–	High	10	25	0.97	1.80	0.19	1.32	–	0.66	1.84	1.77	–	–	5.44	5.36	ns
2.5 V GTL+	33	–	High	10	25	0.97	1.92	0.19	1.26	–	0.66	1.96	1.80	–	–	5.56	5.40	ns
HSTL (I)	8	–	High	20	50	0.97	2.67	0.18	1.72	–	0.66	2.72	2.67	–	–	6.32	6.26	ns
HSTL (II)	15	–	High	20	25	0.97	2.55	0.18	1.72	–	0.66	2.60	2.34	–	–	6.20	5.93	ns
SSTL2 (I)	15	–	High	30	50	0.97	1.86	0.19	1.12	–	0.66	1.90	1.68	–	–	5.50	5.28	ns
SSTL2 (II)	18	–	High	30	25	0.97	1.89	0.19	1.12	–	0.66	1.93	1.62	–	–	5.53	5.22	ns
SSTL3 (I)	14	–	High	30	50	0.97	2.00	0.19	1.06	–	0.66	2.04	1.67	–	–	5.64	5.27	ns
SSTL3 (II)	21	–	High	30	25	0.97	1.81	0.19	1.06	–	0.66	1.85	1.55	–	–	5.45	5.14	ns
LVDS	24	–	High	–	–	0.97	1.73	0.19	1.62	–	–	–	–	–	–	–	–	ns
LVPECL	24	–	High	–	–	0.97	1.65	0.18	1.42	–	–	–	–	–	–	–	–	ns

**Notes:**

1. The minimum drive strength for any LVCMOS 1.2 V or LVCMOS 3.3 V software configuration when run in wide range is  $\pm 100\ \mu\text{A}$ . Drive strength displayed in the software is supported for normal range only. For a detailed I/V curve, refer to the IBIS models.
2. All LVCMOS 3.3 V software macros support LVCMOS 3.3 V wide range as specified in the JESD8-B specification.
3. Resistance is used to measure I/O propagation delays as defined in PCI Specifications. See [Figure 2-12 on page 2-49](#) for connectivity. This resistor is not required during normal operation.
4. Output drive strength is below JEDEC specification.
5. For specific junction temperature and voltage supply levels, refer to [Table 2-6 on page 2-6](#) for derating values.

**Table 2-26 • Summary of I/O Timing Characteristics—Software Default Settings**  
 Std. Speed Grade, Commercial-Case Conditions:  $T_J = 70^\circ\text{C}$ , Worst-Case  $V_{CC} = 1.14\text{ V}$ ,  
 Worst-Case  $V_{CCI}$  (per standard)

I/O Standard	Drive Strength (mA)	Equivalent Software Default Drive Strength Option <sup>1</sup> (mA)	Slew Rate	Capacitive Load (pF)	External Resistor ( $\Omega$ )	$t_{pOUT}$ (ns)	$t_{pP}$ (ns)	$t_{pIN}$ (ns)	$t_{pY}$ (ns)	$t_{pYS}$ (ns)	$t_{pOUT}$ (ns)	$t_{zL}$ (ns)	$t_{zH}$ (ns)	$t_{zL}$ (ns)	$t_{zH}$ (ns)	$t_{zLS}$ (ns)	$t_{zHS}$ (ns)	Units
3.3 V LVTTTL / 3.3 V LVCMOS	12	12	High	5	–	1.55	2.47	0.26	1.31	1.58	1.10	2.51	2.04	3.28	3.97	8.29	7.82	ns
3.3 V LVCMOS Wide Range <sup>1,2</sup>	100 $\mu\text{A}$	12	High	35	–	1.55	3.40	0.26	1.66	2.14	1.10	3.40	2.68	4.55	5.49	9.19	8.46	ns
2.5 V LVCMOS	12	12	High	5	–	1.55	2.51	0.26	1.55	1.77	1.10	2.54	2.22	3.36	3.85	8.33	8.00	ns
1.8 V LVCMOS	12	12	High	5	–	1.55	2.75	0.26	1.53	1.96	1.10	2.78	2.40	3.68	4.56	8.57	8.19	ns
1.5 V LVCMOS	12	12	High	5	–	1.55	3.10	0.26	1.72	2.16	1.10	3.15	2.70	3.86	4.68	8.93	8.49	ns
1.2 V LVCMOS	2	2	High	5	–	1.55	4.06	0.26	2.09	2.95	1.10	3.92	3.46	4.01	3.79	9.71	9.24	ns
1.2 V LVCMOS Wide Range <sup>1,3</sup>	100 $\mu\text{A}$	2	High	5	–	1.55	4.06	0.26	2.09	2.95	1.10	3.92	3.46	4.01	3.79	9.71	9.24	ns
3.3 V PCI	Per PCI spec	–	High	10	25 <sup>4</sup>	1.55	2.76	0.26	1.19	1.63	1.10	2.79	2.16	3.29	3.97	8.58	7.94	ns
3.3 V PCI-X	Per PCI-X spec	–	High	10	25 <sup>4</sup>	1.55	2.76	0.25	1.22	1.58	1.10	2.79	2.16	3.29	3.97	8.58	7.94	ns
3.3 V GTL	20 <sup>5</sup>	–	High	10	25	1.55	2.08	0.25	2.76	–	1.10	2.09	2.08	–	–	7.88	7.87	ns
2.5 V GTL	20 <sup>5</sup>	–	High	10	25	1.55	2.17	0.25	2.35	–	1.10	2.20	2.13	–	–	7.99	7.91	ns
3.3 V GTL+	35	–	High	10	25	1.55	2.12	0.25	1.62	–	1.10	2.14	2.07	–	–	7.93	7.85	ns
2.5 V GTL+	33	–	High	10	25	1.55	2.25	0.25	1.55	–	1.10	2.27	2.10	–	–	8.06	7.89	ns
HSTL (I)	8	–	High	20	50	1.55	3.09	0.25	1.95	–	1.10	3.11	3.09	–	–	8.90	8.88	ns
HSTL (II)	15	–	High	20	25	1.55	2.94	0.25	1.95	–	1.10	2.98	2.74	–	–	8.77	8.53	ns
SSTL2 (I)	15	–	High	30	50	1.55	2.18	0.25	1.40	–	1.10	2.21	2.03	–	–	7.99	7.82	ns
SSTL2 (II)	18	–	High	30	25	1.55	2.21	0.25	1.40	–	1.10	2.24	1.97	–	–	8.03	7.76	ns
SSTL3 (I)	14	–	High	30	50	1.55	2.33	0.25	1.33	–	1.10	2.36	2.02	–	–	8.15	7.81	ns
SSTL3 (II)	21	–	High	30	25	1.55	2.13	0.25	1.33	–	1.10	2.16	1.89	–	–	7.94	7.67	ns

**Notes:**

1. The minimum drive strength for any LVCMOS 1.2 V or LVCMOS 3.3 V software configuration when run in wide range is  $\pm 100\ \mu\text{A}$ . Drive strength displayed in the software is supported for normal range only. For a detailed I/V curve, refer to the IBIS models.
2. All LVCMOS 3.3 V software macros support LVCMOS 3.3 V wide range as specified in the JESD8-B specification.
3. All LVCMOS 1.2 V software macros support LVCMOS 1.2 V wide range as specified in the JESD8-12 specification.
4. Resistance is used to measure I/O propagation delays as defined in PCI specifications. See [Figure 2-12 on page 2-49](#) for connectivity. This resistor is not required during normal operation.
5. Output drive strength is below JEDEC specification.
6. For specific junction temperature and voltage supply levels, refer to [Table 2-7 on page 2-6](#) for derating values.

**Table 2-26 • Summary of I/O Timing Characteristics—Software Default Settings (continued)**  
 Std. Speed Grade, Commercial-Case Conditions:  $T_J = 70^\circ\text{C}$ , Worst-Case  $V_{CC} = 1.14\text{ V}$ ,  
 Worst-Case  $V_{CCI}$  (per standard)

I/O Standard	Drive Strength (mA)	Equivalent Software Default Drive Strength Option <sup>1</sup> (mA)	Slew Rate	Capacitive Load (pF)	External Resistor ( $\Omega$ )	$t_{pOUT}$ (ns)	$t_{pP}$ (ns)	$t_{pIN}$ (ns)	$t_{pY}$ (ns)	$t_{pYS}$ (ns)	$t_{EOUT}$ (ns)	$t_{ZL}$ (ns)	$t_{ZH}$ (ns)	$t_{LZ}$ (ns)	$t_{HZ}$ (ns)	$t_{ZLS}$ (ns)	$t_{ZHS}$ (ns)	Units
LVDS	24	–	High	–	–	1.55	2.26	0.25	1.95	–	–	–	–	–	–	–	–	ns
LVPECL	24	–	High	–	–	1.55	2.17	0.25	1.70	–	–	–	–	–	–	–	–	ns

**Notes:**

1. The minimum drive strength for any LVCMOS 1.2 V or LVCMOS 3.3 V software configuration when run in wide range is  $\pm 100\ \mu\text{A}$ . Drive strength displayed in the software is supported for normal range only. For a detailed I/V curve, refer to the IBIS models.
2. All LVCMOS 3.3 V software macros support LVCMOS 3.3 V wide range as specified in the JESD8-B specification.
3. All LVCMOS 1.2 V software macros support LVCMOS 1.2 V wide range as specified in the JESD8-12 specification.
4. Resistance is used to measure I/O propagation delays as defined in PCI specifications. See [Figure 2-12 on page 2-49](#) for connectivity. This resistor is not required during normal operation.
5. Output drive strength is below JEDEC specification.
6. For specific junction temperature and voltage supply levels, refer to [Table 2-7 on page 2-6](#) for derating values.

## Detailed I/O DC Characteristics

**Table 2-27 • Input Capacitance**

Symbol	Definition	Conditions	Min.	Max.	Units
$C_{IN}$	Input capacitance	$V_{IN} = 0, f = 1.0 \text{ MHz}$		8	pF
$C_{INCLK}$	Input capacitance on the clock pin	$V_{IN} = 0, f = 1.0 \text{ MHz}$		8	pF

**Table 2-28 • I/O Output Buffer Maximum Resistances<sup>1</sup>**

Standard	Drive Strength	$R_{PULL-DOWN} (\Omega)^2$	$R_{PULL-UP} (\Omega)^3$
3.3 V LVTTTL / 3.3 V LVCMOS	4 mA	100	300
	8 mA	50	150
	12 mA	25	75
	16 mA	17	50
	24 mA	11	33
3.3 V LVCMOS Wide Range	100 $\mu\text{A}$	Same as regular 3.3 V LVCMOS	Same as regular 3.3 V LVCMOS
2.5 V LVCMOS	4 mA	100	200
	8 mA	50	100
	12 mA	25	50
	16 mA	20	40
	24 mA	11	22
1.8 V LVCMOS	2 mA	200	225
	4 mA	100	112
	6 mA	50	56
	8 mA	50	56
	12 mA	20	22
	16 mA	20	22
1.5 V LVCMOS	2 mA	200	224
	4 mA	100	112
	6 mA	67	75
	8 mA	33	37
	12 mA	33	37
1.2 V LVCMOS <sup>4</sup>	2 mA	158	164
1.2 V LVCMOS Wide Range <sup>4</sup>	100 $\mu\text{A}$	Same as regular 1.2 V LVCMOS	Same as regular 1.2 V LVCMOS

**Notes:**

1. These maximum values are provided for informational reasons only. Minimum output buffer resistance values depend on VCCI, drive strength selection, temperature, and process. For board design considerations and detailed output buffer resistances, use the corresponding IBIS models located on the Microsemi SoC Products Group website at <http://www.microsemi.com/soc/techdocs/models/ibis.html>.
2.  $R_{(PULL-DOWN-MAX)} = (V_{OLspec}) / I_{OLspec}$
3.  $R_{(PULL-UP-MAX)} = (V_{CCImax} - V_{OHspec}) / I_{OHspec}$
4. Applicable to IGLOOe V2 devices operating in the 1.2 V core range ONLY.
5. Output drive strength is below JEDEC specification.

**Table 2-28 • I/O Output Buffer Maximum Resistances<sup>1</sup> (continued)**

Standard	Drive Strength	R <sub>PULL-DOWN</sub> (Ω) <sup>2</sup>	R <sub>PULL-UP</sub> (Ω) <sup>3</sup>
3.3 V PCI/PCI-X	Per PCI/PCI-X specification	25	75
3.3 V GTL	20 mA <sup>5</sup>	11	–
2.5 V GTL	20 mA <sup>5</sup>	14	–
3.3 V GTL+	35 mA	12	–
2.5 V GTL+	33 mA	15	–
HSTL (I)	8 mA	50	50
HSTL (II)	15 mA	25	25
SSTL2 (I)	15 mA	27	31
SSTL2 (II)	18 mA	13	15
SSTL3 (I)	14 mA	44	69
SSTL3 (II)	21 mA	18	32

**Notes:**

1. These maximum values are provided for informational reasons only. Minimum output buffer resistance values depend on VCCI, drive strength selection, temperature, and process. For board design considerations and detailed output buffer resistances, use the corresponding IBIS models located on the Microsemi SoC Products Group website at <http://www.microsemi.com/soc/techdocs/models/ibis.html>.
2.  $R_{(PULL-DOWN-MAX)} = (VOL_{spec}) / IOL_{spec}$
3.  $R_{(PULL-UP-MAX)} = (VCCI_{max} - VOH_{spec}) / IOH_{spec}$
4. Applicable to IGLOOe V2 devices operating in the 1.2 V core range ONLY.
5. Output drive strength is below JEDEC specification.

**Table 2-29 • I/O Weak Pull-Up/Pull-Down Resistances  
Minimum and Maximum Weak Pull-Up/Pull-Down Resistance Values**

VCCI	R <sub>(WEAK PULL-UP)</sub> <sup>1</sup> (Ω)		R <sub>(WEAK PULL-DOWN)</sub> <sup>2</sup> (Ω)	
	Minimum	Maximum	Minimum	Maximum
3.3 V	10 k	45 k	10 k	45 k
3.3 V (wide range I/Os)	10 k	45 k	10 k	45 k
2.5 V	11 k	55 k	12 k	74 k
1.8 V	18 k	70 k	17 k	110 k
1.5 V	19 k	90 k	19 k	140 k
1.2 V	25 k	110 k	25 k	150 k
1.2 V (wide range I/Os)	19 k	110 k	19 k	150 k

**Notes:**

1.  $R_{(WEAK PULL-UP-MAX)} = (VCCI_{max} - VOH_{spec}) / I_{(WEAK PULL-UP-MIN)}$
2.  $R_{(WEAK PULL-DOWN-MAX)} = (VOL_{spec}) / I_{(WEAK PULL-DOWN-MIN)}$

**Table 2-30 • I/O Short Currents IOSH/IOSL**

	Drive Strength	IOSH (mA)*	IOSL (mA)*
3.3 V LVTTTL / 3.3 V LVCMOS	4 mA	25	27
	8 mA	51	54
	12 mA	103	109
	16 mA	132	127
	24 mA	268	181
3.3 V LVCMOS Wide Range	100 $\mu$ A	Same as regular 3.3 V LVCMOS	Same as regular 3.3 V LVCMOS
2.5 V LVCMOS	4 mA	16	18
	8 mA	32	37
	12 mA	65	74
	16 mA	83	87
	24 mA	169	124
1.8 V LVCMOS	2 mA	9	11
	4 mA	17	22
	6 mA	35	44
	8 mA	45	51
	12 mA	91	74
	16 mA	91	74
1.5 V LVCMOS	2 mA	13	16
	4 mA	25	33
	6 mA	32	39
	8 mA	66	55
	12 mA	66	55
1.2 V LVCMOS	2 mA	20	26
1.2 V LVCMOS Wide Range	100 $\mu$ A	20	26
3.3 V PCI/PCIX	Per PCI/PCI-X Specification	Per PCI Curves	
3.3 V GTL	25 mA	268	181
2.5 V GTL	25 mA	169	124
3.3 V GTL+	35 mA	268	181
2.5 V GTL+	33 mA	169	124
HSTL (I)	8 mA	32	39
HSTL (II)	15 mA	66	55
SSTL2 (I)	15 mA	83	87
SSTL2 (II)	18 mA	169	124
SSTL3 (I)	14 mA	51	54
SSTL3 (II)	21 mA	103	109

Note:  $T_J = 100^\circ\text{C}$

The length of time an I/O can withstand IOSH/IOSL events depends on the junction temperature. The reliability data below is based on a 3.3 V, 36 mA I/O setting, which is the worst case for this type of analysis.

For example, at 100°C, the short current condition would have to be sustained for more than six months to cause a reliability concern. The I/O design does not contain any short circuit protection, but such protection would only be needed in extremely prolonged stress conditions.

**Table 2-31 • Duration of Short Circuit Event before Failure**

Temperature	Time before Failure
-40°C	> 20 years
0°C	> 20 years
25°C	> 20 years
70°C	5 years
85°C	2 years
100°C	6 months

**Table 2-32 • Schmitt Trigger Input Hysteresis Hysteresis Voltage Value (Typ.) for Schmitt Mode Input Buffers**

Input Buffer Configuration	Hysteresis Value (typ.)
3.3 V LVTTTL/LVCMOS/PCI/PCI-X (Schmitt trigger mode)	240 mV
2.5 V LVCMOS (Schmitt trigger mode)	140 mV
1.8 V LVCMOS (Schmitt trigger mode)	80 mV
1.5 V LVCMOS (Schmitt trigger mode)	60 mV
1.2 V LVCMOS (Schmitt trigger mode)	40 mV

**Table 2-33 • I/O Input Rise Time, Fall Time, and Related I/O Reliability\***

Input Buffer	Input Rise/Fall Time (min.)	Input Rise/Fall Time (max.)	Reliability
LVTTTL/LVCMOS (Schmitt trigger disabled)	No requirement	10 ns*	20 years (100°C)
LVTTTL/LVCMOS (Schmitt trigger enabled)	No requirement	No requirement, but input noise voltage cannot exceed Schmitt hysteresis.	20 years (100°C)
HSTL/SSTL/GTL	No requirement	10 ns*	10 years (100°C)
LVDS/B-LVDS/M-LVDS/LVPECL	No requirement	10 ns*	10 years (100°C)

**Note:** \*The maximum input rise/fall time is related to the noise induced into the input buffer trace. If the noise is low, then the rise time and fall time of input buffers can be increased beyond the maximum value. The longer the rise/fall times, the more susceptible the input signal is to the board noise. Microsemi recommends signal integrity evaluation/characterization of the system to ensure that there is no excessive noise coupling into input signals.

## Single-Ended I/O Characteristics

### 3.3 V LVTTTL / 3.3 V LVCMOS

Low-Voltage Transistor–Transistor Logic is a general purpose standard (EIA/JESD) for 3.3 V applications. It uses an LVTTTL input buffer and push-pull output buffer. The 3.3 V LVCMOS standard is supported as part of the 3.3 V LVTTTL support.

**Table 2-34 • Minimum and Maximum DC Input and Output Levels**

3.3 V LVTTTL / 3.3 V LVCMOS	VIL		VIH		VOL	VOH	IOL	IOH	IOSH	IOSL	IIL <sup>1</sup>	IIH <sup>2</sup>
	Min. V	Max. V	Min. V	Max. V	Max. V	Min. V	mA	mA	Max. mA <sup>3</sup>	Max. mA <sup>3</sup>	μA <sup>4</sup>	μA <sup>4</sup>
4 mA	-0.3	0.8	2	3.6	0.4	2.4	4	4	25	27	10	10
8 mA	-0.3	0.8	2	3.6	0.4	2.4	8	8	51	54	10	10
12 mA	-0.3	0.8	2	3.6	0.4	2.4	12	12	103	109	10	10
16 mA	-0.3	0.8	2	3.6	0.4	2.4	16	16	132	127	10	10
24 mA	-0.3	0.8	2	3.6	0.4	2.4	24	24	268	181	10	10

**Notes:**

1. IIL is the input leakage current per I/O pin over recommended operation conditions where  $-0.3\text{ V} < V_{IN} < V_{IL}$ .
2. IIH is the input leakage current per I/O pin over recommended operating conditions  $V_{IH} < V_{IN} < V_{CCI}$ . Input current is larger when operating outside recommended ranges.
3. Currents are measured at high temperature (100°C junction temperature) and maximum voltage.
4. Currents are measured at 85°C junction temperature.
5. Software default selection highlighted in gray.

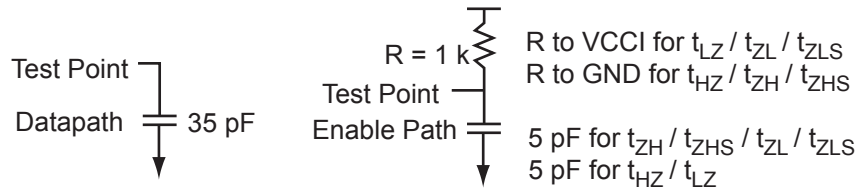

**Figure 2-7 • AC Loading**

**Table 2-35 • AC Waveforms, Measuring Points, and Capacitive Loads**

Input Low (V)	Input High (V)	Measuring Point* (V)	VREF (typ.) (V)	C <sub>LOAD</sub> (pF)
0	3.3	1.4	–	5

*Note:* \*Measuring point = Vtrip. See Table 2-23 on page 2-23 for a complete table of trip points.

## Timing Characteristics

### 1.5 V DC Core Voltage

**Table 2-36 • 3.3 V LVTTTL / 3.3 V LVCMOS Low Slew – Applies to 1.5 V DC Core Voltage**  
**Commercial-Case Conditions:  $T_J = 70^\circ\text{C}$ , Worst-Case VCC = 1.425 V, Worst-Case VCCI = 3.0 V**

Drive Strength	Speed Grade	$t_{DOUT}$	$t_{DP}$	$t_{DIN}$	$t_{PY}$	$t_{PYS}$	$t_{EOUT}$	$t_{ZL}$	$t_{ZH}$	$t_{LZ}$	$t_{HZ}$	$t_{ZLS}$	$t_{ZHS}$	Units
4 mA	Std.	0.97	4.90	0.18	1.08	1.34	0.66	5.00	3.99	2.27	2.16	8.60	7.59	ns
8 mA	Std.	0.97	4.05	0.18	1.08	1.34	0.66	4.13	3.45	2.53	2.65	7.73	7.05	ns
12 mA	Std.	0.97	3.44	0.18	1.08	1.34	0.66	3.51	3.05	2.71	2.95	7.11	6.64	ns
16 mA	Std.	0.97	3.27	0.18	1.08	1.34	0.66	3.34	2.96	2.74	3.04	6.93	6.55	ns
24 mA	Std.	0.97	3.18	0.18	1.08	1.34	0.66	3.24	2.97	2.79	3.36	6.84	6.56	ns

*Note:* For specific junction temperature and voltage supply levels, refer to [Table 2-6 on page 2-6](#) for derating values.

**Table 2-37 • 3.3 V LVTTTL / 3.3 V LVCMOS High Slew – Applies to 1.5 V DC Core Voltage**  
**Commercial-Case Conditions:  $T_J = 70^\circ\text{C}$ , Worst-Case VCC = 1.425 V, Worst-Case VCCI = 3.0 V**

Drive Strength	Speed Grade	$t_{DOUT}$	$t_{DP}$	$t_{DIN}$	$t_{PY}$	$t_{PYS}$	$t_{EOUT}$	$t_{ZL}$	$t_{ZH}$	$t_{LZ}$	$t_{HZ}$	$t_{ZLS}$	$t_{ZHS}$	Units
4 mA	Std.	0.97	2.85	0.18	1.08	1.34	0.66	2.92	2.27	2.27	2.27	6.51	5.87	ns
8 mA	Std.	0.97	2.39	0.18	1.08	1.34	0.66	2.44	1.88	2.53	2.76	6.03	5.47	ns
12 mA	Std.	0.97	2.12	0.18	1.08	1.34	0.66	2.17	1.69	2.71	3.08	5.76	5.28	ns
16 mA	Std.	0.97	2.08	0.18	1.08	1.34	0.66	2.12	1.65	2.75	3.17	5.72	5.25	ns
24 mA	Std.	0.97	2.10	0.18	1.08	1.34	0.66	2.14	1.60	2.80	3.49	5.74	5.20	ns

*Notes:*

1. Software default selection highlighted in gray.
2. For specific junction temperature and voltage supply levels, refer to [Table 2-6 on page 2-6](#) for derating values.

### 1.2 V DC Core Voltage

**Table 2-38 • 3.3 V LVTTTL / 3.3 V LVCMOS Low Slew – Applies to 1.2 V DC Core Voltage**  
 Commercial-Case Conditions:  $T_J = 70^\circ\text{C}$ , Worst-Case VCC = 1.14 V, Worst-Case VCCI = 3.0 V

Drive Strength	Speed Grade	$t_{DOUT}$	$t_{DP}$	$t_{DIN}$	$t_{PY}$	$t_{PYS}$	$t_{EOUT}$	$t_{ZL}$	$t_{ZH}$	$t_{LZ}$	$t_{HZ}$	$t_{ZLS}$	$t_{ZHS}$	Units
4 mA	Std.	1.55	5.54	0.26	1.31	1.58	1.10	5.63	4.53	2.79	2.87	11.42	10.32	ns
8 mA	Std.	1.55	4.60	0.26	1.31	1.58	1.10	4.67	3.94	3.09	3.45	10.45	9.73	ns
12 mA	Std.	1.55	3.93	0.26	1.31	1.58	1.10	3.99	3.51	3.28	3.82	9.77	9.29	ns
16 mA	Std.	1.55	3.74	0.26	1.31	1.58	1.10	3.79	3.41	3.32	3.92	9.58	9.20	ns
24 mA	Std.	1.55	3.64	0.26	1.31	1.58	1.10	3.69	3.42	3.38	4.30	9.48	9.21	ns

*Note:* For specific junction temperature and voltage supply levels, refer to [Table 2-7 on page 2-6](#) for derating values.

**Table 2-39 • 3.3 V LVTTTL / 3.3 V LVCMOS High Slew – Applies to 1.2 V DC Core Voltage**  
 Commercial-Case Conditions:  $T_J = 70^\circ\text{C}$ , Worst-Case VCC = 1.14 V, Worst-Case VCCI = 3.0 V

Drive Strength	Speed Grade	$t_{DOUT}$	$t_{DP}$	$t_{DIN}$	$t_{PY}$	$t_{PYS}$	$t_{EOUT}$	$t_{ZL}$	$t_{ZH}$	$t_{LZ}$	$t_{HZ}$	$t_{ZLS}$	$t_{ZHS}$	Units
4 mA	Std.	1.55	3.26	0.26	1.31	1.58	1.10	3.33	2.67	2.79	3.01	9.12	8.46	ns
8 mA	Std.	1.55	2.77	0.26	1.31	1.58	1.10	2.80	2.24	3.09	3.59	8.59	8.03	ns
12 mA	Std.	1.55	2.47	0.26	1.31	1.58	1.10	2.51	2.04	3.28	3.97	8.29	7.82	ns
16 mA	Std.	1.55	2.42	0.26	1.31	1.58	1.10	2.46	2.00	3.33	4.08	8.24	7.79	ns
24 mA	Std.	1.55	2.45	0.26	1.31	1.58	1.10	2.48	1.95	3.38	4.46	8.26	7.73	ns

*Notes:*

1. Software default selection highlighted in gray.
2. For specific junction temperature and voltage supply levels, refer to [Table 2-7 on page 2-6](#) for derating values.

### 3.3 V LVCMOS Wide Range

Table 2-40 • Minimum and Maximum DC Input and Output Levels

3.3 V LVCMOS Wide Range		VIL		VIH		VOL	VOH	IOL	IOH	IOSH	IOSL	IIL <sup>1</sup>	IIH <sup>2</sup>
Drive Strength	Equivalent Software Default Drive Strength Option <sup>3</sup>	Min. (V)	Max. (V)	Min. (V)	Max (V)	Max. (V)	Min. (V)	$\mu\text{A}$	$\mu\text{A}$	Max. (mA) <sup>4</sup>	Max. (mA) <sup>4</sup>	$\mu\text{A}$ <sup>5</sup>	$\mu\text{A}$ <sup>5</sup>
100 $\mu\text{A}$	2 mA	-0.3	0.8	2	3.6	0.2	VDD - 0.2	100	100	25	27	10	10
100 $\mu\text{A}$	4 mA	-0.3	0.8	2	3.6	0.2	VDD - 0.2	100	100	25	27	10	10
100 $\mu\text{A}$	6 mA	-0.3	0.8	2	3.6	0.2	VDD - 0.2	100	100	51	54	10	10
100 $\mu\text{A}$	8 mA	-0.3	0.8	2	3.6	0.2	VDD - 0.2	100	100	51	54	10	10
100 $\mu\text{A}$	12 mA	-0.3	0.8	2	3.6	0.2	VDD - 0.2	100	100	103	109	10	10
100 $\mu\text{A}$	16 mA	-0.3	0.8	2	3.6	0.2	VDD - 0.2	100	100	132	127	10	10
100 $\mu\text{A}$	24 mA	-0.3	0.8	2	3.6	0.2	VDD - 0.2	100	100	268	181	10	10

**Notes:**

1. IIL is the input leakage current per I/O pin over recommended operation conditions where  $-0.3\text{ V} < V_{IN} < V_{IL}$ .
2. IIH is the input leakage current per I/O pin over recommended operating conditions  $V_{IH} < V_{IN} < V_{CCI}$ . Input current is larger when operating outside recommended ranges.
3. The minimum drive strength for any LVCMOS 3.3 V software configuration when run in wide range is  $\pm 100\ \mu\text{A}$ . Drive strength displayed in the software is supported for normal range only. For a detailed I/V curve, refer to the IBIS models.
4. Currents are measured at 85°C junction temperature.
5. All LVCMOS 3.3 V software macros supports LVCMOS 3.3 V wide range as specified in the JEDEC8a specification.
6. Software default selection highlighted in gray.

Table 2-41 • AC Waveforms, Measuring Points, and Capacitive Loads

Input Low (V)	Input High (V)	Measuring Point* (V)	VREF (typ.) (V)	C <sub>LOAD</sub> (pF)
0	3.3	1.4	-	5

Note: \*Measuring point = Vtrip. See Table 2-23 on page 2-23 for a complete table of trip points.

### Timing Characteristics

#### 1.5 V DC Core Voltage

**Table 2-42 • 3.3 V LVC MOS Wide Range Low Slew – Applies to 1.5 V DC Core Voltage**  
 Commercial-Case Conditions:  $T_J = 70^\circ\text{C}$ , Worst-Case VCC = 1.425 V, Worst-Case VCCI = 2.7 V

Drive Strength	Equivalent Software Default Drive Strength Option <sup>1</sup>	Speed Grade	t <sub>DOUT</sub>	t <sub>DP</sub>	t <sub>DIN</sub>	t <sub>PY</sub>	t <sub>PYS</sub>	t <sub>EOUT</sub>	t <sub>ZL</sub>	t <sub>ZH</sub>	t <sub>LZ</sub>	t <sub>HZ</sub>	t <sub>ZLS</sub>	t <sub>ZHS</sub>	Units
100 $\mu\text{A}$	4 mA	Std.	0.97	7.26	0.18	1.42	1.84	0.66	7.28	5.78	3.18	2.93	10.88	9.38	ns
100 $\mu\text{A}$	8 mA	Std.	0.97	5.94	0.18	1.42	1.84	0.66	5.96	4.96	3.59	3.69	9.56	8.56	ns
100 $\mu\text{A}$	12 mA	Std.	0.97	5.00	0.18	1.42	1.84	0.66	5.02	4.34	3.86	4.16	8.62	7.94	ns
100 $\mu\text{A}$	16 mA	Std.	0.97	4.73	0.18	1.42	1.84	0.66	4.75	4.21	3.92	4.29	8.35	7.81	ns
100 $\mu\text{A}$	24 mA	Std.	0.97	4.59	0.18	1.42	1.84	0.66	4.61	4.23	3.99	4.78	8.21	7.82	ns

**Notes:**

1. The minimum drive strength for any LVC MOS 3.3 V software configuration when run in wide range is  $\pm 100 \mu\text{A}$ . Drive strength displayed in the software is supported for normal range only. For a detailed I/V curve, refer to the IBIS models.
2. For specific junction temperature and voltage supply levels, refer to [Table 2-6 on page 2-6](#) for derating values.

**Table 2-43 • 3.3 V LVC MOS Wide Range High Slew – Applies to 1.5 V DC Core Voltage**  
 Commercial-Case Conditions:  $T_J = 70^\circ\text{C}$ , Worst-Case VCC = 1.425 V, Worst-Case VCCI = 2.7 V

Drive Strength	Equivalent Software Default Drive Strength Option <sup>1</sup>	Speed Grade	t <sub>DOUT</sub>	t <sub>DP</sub>	t <sub>DIN</sub>	t <sub>PY</sub>	t <sub>PYS</sub>	t <sub>EOUT</sub>	t <sub>ZL</sub>	t <sub>ZH</sub>	t <sub>LZ</sub>	t <sub>HZ</sub>	t <sub>ZLS</sub>	t <sub>ZHS</sub>	Units
100 $\mu\text{A}$	4 mA	Std.	0.97	4.10	0.18	1.42	1.84	0.66	4.12	3.17	3.18	3.11	7.71	6.77	ns
100 $\mu\text{A}$	8 mA	Std.	0.97	3.37	0.18	1.42	1.84	0.66	3.39	2.57	3.59	3.87	6.99	6.16	ns
100 $\mu\text{A}$	12 mA	Std.	0.97	2.96	0.18	1.42	1.84	0.66	2.98	2.28	3.86	4.36	6.58	5.87	ns
100 $\mu\text{A}$	16 mA	Std.	0.97	2.90	0.18	1.42	1.84	0.66	2.92	2.22	3.93	4.49	6.51	5.82	ns
100 $\mu\text{A}$	24 mA	Std.	0.97	2.92	0.18	1.42	1.84	0.66	2.94	2.15	4.00	4.99	6.54	5.75	ns

**Notes:**

1. The minimum drive strength for any or LVC MOS 3.3 V software configuration when run in wide range is  $\pm 100 \mu\text{A}$ . Drive strength displayed in the software is supported for normal range only. For a detailed I/V curve, refer to the IBIS models.
2. For specific junction temperature and voltage supply levels, refer to [Table 2-6 on page 2-6](#) for derating values.
3. Software default selection highlighted in gray.

**1.2 V DC Core Voltage**

**Table 2-44 • 3.3 V LVC MOS Wide Range Low Slew – Applies to 1.2 V DC Core Voltage**  
**Commercial-Case Conditions: T<sub>J</sub> = 70°C, Worst-Case VCC = 1.14 V, Worst-Case VCCI = 2.7 V**

Drive Strength	Equivalent Software Default Drive Strength Option <sup>1</sup>	Speed Grade	t <sub>DOUT</sub>	t <sub>DP</sub>	t <sub>DIN</sub>	t <sub>PY</sub>	t <sub>PYS</sub>	t <sub>EOUT</sub>	t <sub>ZL</sub>	t <sub>ZH</sub>	t <sub>LZ</sub>	t <sub>HZ</sub>	t <sub>ZLS</sub>	t <sub>ZHS</sub>	Units
100 μA	4 mA	Std.	1.55	8.14	0.26	1.66	2.14	1.10	8.14	6.46	3.80	3.79	13.93	12.25	ns
100 μA	8 mA	Std.	1.55	6.68	0.26	1.66	2.14	1.10	6.68	5.57	4.25	4.69	12.47	11.36	ns
100 μA	12 mA	Std.	1.55	5.65	0.26	1.66	2.14	1.10	5.65	4.91	4.55	5.25	11.44	10.69	ns
100 μA	16 mA	Std.	1.55	5.36	0.26	1.66	2.14	1.10	5.36	4.76	4.61	5.41	11.14	10.55	ns
100 μA	24 mA	Std.	1.55	5.20	0.26	1.66	2.14	1.10	5.20	4.78	4.69	6.00	10.99	10.56	ns

**Notes:**

1. The minimum drive strength for any LVC MOS 3.3 V software configuration when run in wide range is ±100 μA. Drive strength displayed in the software is supported for normal range only. For a detailed I/V curve, refer to the IBIS models.
2. For specific junction temperature and voltage supply levels, refer to [Table 2-7 on page 2-6](#) for derating values.

**Table 2-45 • 3.3 V LVC MOS Wide Range High Slew – Applies to 1.2 V DC Core Voltage**  
**Commercial-Case Conditions: T<sub>J</sub> = 70°C, Worst-Case VCC = 1.14 V, Worst-Case VCCI = 2.7 V**

Drive Strength	Equivalent Software Default Drive Strength Option <sup>1</sup>	Speed Grade	t <sub>DOUT</sub>	t <sub>DP</sub>	t <sub>DIN</sub>	t <sub>PY</sub>	t <sub>PYS</sub>	t <sub>EOUT</sub>	t <sub>ZL</sub>	t <sub>ZH</sub>	t <sub>LZ</sub>	t <sub>HZ</sub>	t <sub>ZLS</sub>	t <sub>ZHS</sub>	Units
100 μA	4 mA	Std.	1.55	4.65	0.26	1.66	2.14	1.10	4.65	3.64	3.80	4.00	10.44	9.43	ns
100 μA	8 mA	Std.	1.55	3.85	0.26	1.66	2.14	1.10	3.85	2.99	4.25	4.91	9.64	8.77	ns
100 μA	12 mA	Std.	1.55	3.40	0.26	1.66	2.14	1.10	3.40	2.68	4.55	5.49	9.19	8.46	ns
100 μA	16 mA	Std.	1.55	3.33	0.26	1.66	2.14	1.10	3.33	2.62	4.62	5.65	9.11	8.41	ns
100 μA	24 mA	Std.	1.55	3.36	0.26	1.66	2.14	1.10	3.36	2.54	4.71	6.24	9.15	8.32	ns

**Notes:**

1. The minimum drive strength for any LVC MOS 3.3 V software configuration when run in wide range is ±100 μA. Drive strength displayed in the software is supported for normal range only. For a detailed I/V curve, refer to the IBIS models.
2. For specific junction temperature and voltage supply levels, refer to [Table 2-7 on page 2-6](#) for derating values.
3. Software default selection highlighted in gray.

## 2.5 V LVCMOS

Low-Voltage CMOS for 2.5 V is an extension of the LVCMOS standard (JESD8-5) used for general-purpose 2.5 V applications.

**Table 2-46 • Minimum and Maximum DC Input and Output Levels**

2.5 V LVCMOS Drive Strength	VIL		VIH		VOL	VOH	IOL	IOH	IOSH	IOSL	IIL <sup>1</sup>	IIH <sup>2</sup>
	Min. V	Max. V	Min. V	Max. V	Max. V	Min. V	mA	mA	Max. mA <sup>3</sup>	Max. mA <sup>3</sup>	μA <sup>4</sup>	μA <sup>4</sup>
4 mA	-0.3	0.7	1.7	3.6	0.7	1.7	4	4	16	18	10	10
8 mA	-0.3	0.7	1.7	3.6	0.7	1.7	8	8	32	37	10	10
12 mA	-0.3	0.7	1.7	3.6	0.7	1.7	12	12	65	74	10	10
16 mA	-0.3	0.7	1.7	3.6	0.7	1.7	16	16	83	87	10	10
24 mA	-0.3	0.7	1.7	3.6	0.7	1.7	24	24	169	124	10	10

**Notes:**

1. IIL is the input leakage current per I/O pin over recommended operation conditions where  $-0.3\text{ V} < V_{IN} < V_{IL}$ .
2. IIH is the input leakage current per I/O pin over recommended operating conditions  $V_{IH} < V_{IN} < V_{CCI}$ . Input current is larger when operating outside recommended ranges.
3. Currents are measured at high temperature (100°C junction temperature) and maximum voltage.
4. Currents are measured at 85°C junction temperature.
5. Software default selection highlighted in gray.

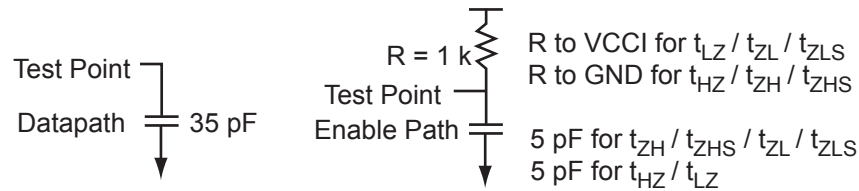

**Figure 2-8 • AC Loading**

**Table 2-47 • AC Waveforms, Measuring Points, and Capacitive Loads**

Input Low (V)	Input High (V)	Measuring Point* (V)	VREF (typ.) (V)	C <sub>LOAD</sub> (pF)
0	2.5	1.2	-	5

Note: \*Measuring point =  $V_{trip}$ . See Table 2-23 on page 2-23 for a complete table of trip points.

## Timing Characteristics

### 1.5 V DC Core Voltage

**Table 2-48 • 2.5 V LVCMOS Low Slew – Applies to 1.5 V DC Core Voltage**

Commercial-Case Conditions:  $T_J = 70^\circ\text{C}$ , Worst-Case VCC = 1.425 V, Worst-Case VCCI = 2.3 V

Drive Strength	Speed Grade	$t_{DOUT}$	$t_{DP}$	$t_{DIN}$	$t_{PY}$	$t_{PYS}$	$t_{EOUT}$	$t_{ZL}$	$t_{ZH}$	$t_{LZ}$	$t_{HZ}$	$t_{ZLS}$	$t_{ZHS}$	Unit
4 mA	Std.	0.97	5.55	0.18	1.31	1.41	0.66	5.66	4.75	2.28	1.96	9.26	8.34	ns
8 mA	Std.	0.97	4.58	0.18	1.31	1.41	0.66	4.67	4.07	2.58	2.53	8.27	7.66	ns
12 mA	Std.	0.97	3.89	0.18	1.31	1.41	0.66	3.97	3.58	2.78	2.91	7.56	7.17	ns
16 mA	Std.	0.97	3.68	0.18	1.31	1.41	0.66	3.75	3.47	2.82	3.01	7.35	7.06	ns
24 mA	Std.	0.97	3.59	0.18	1.31	1.41	0.66	3.66	3.48	2.88	3.37	7.26	7.08	ns

Note: For specific junction temperature and voltage supply levels, refer to Table 2-6 on page 2-6 for derating values.

**Table 2-49 • 2.5 V LVCMOS High Slew – Applies to 1.5 V DC Core Voltage**

Commercial-Case Conditions:  $T_J = 70^\circ\text{C}$ , Worst-Case VCC = 1.425 V, Worst-Case VCCI = 2.3 V

Drive Strength	Speed Grade	$t_{DOUT}$	$t_{DP}$	$t_{DIN}$	$t_{PY}$	$t_{PYS}$	$t_{EOUT}$	$t_{ZL}$	$t_{ZH}$	$t_{LZ}$	$t_{HZ}$	$t_{ZLS}$	$t_{ZHS}$	Unit
4 mA	Std.	0.97	2.94	0.18	1.31	1.41	0.66	3.00	2.68	2.28	2.03	6.60	6.27	ns
8 mA	Std.	0.97	2.45	0.18	1.31	1.41	0.66	2.50	2.12	2.58	2.62	6.10	5.72	ns
12 mA	Std.	0.97	2.15	0.18	1.31	1.41	0.66	2.20	1.85	2.78	2.98	5.80	5.45	ns
16 mA	Std.	0.97	2.10	0.18	1.31	1.41	0.66	2.15	1.80	2.82	3.08	5.75	5.40	ns
24 mA	Std.	0.97	2.11	0.18	1.31	1.41	0.66	2.16	1.74	2.88	3.47	5.75	5.33	ns

Notes:

1. Software default selection highlighted in gray.
2. For specific junction temperature and voltage supply levels, refer to Table 2-6 on page 2-6 for derating values.

### 1.2 V DC Core Voltage

**Table 2-50 • 2.5 V LVCMOS Low Slew – Applies to 1.2 V DC Core Voltage**  
**Commercial-Case Conditions:  $T_J = 70^\circ\text{C}$ , Worst-Case VCC = 1.14 V, Worst-Case VCCI = 2.3 V**

Drive Strength	Speed Grade	$t_{DOUT}$	$t_{DP}$	$t_{DIN}$	$t_{PY}$	$t_{PYS}$	$t_{EOUT}$	$t_{ZL}$	$t_{ZH}$	$t_{LZ}$	$t_{HZ}$	$t_{ZLS}$	$t_{ZHS}$	Units
4 mA	Std.	1.55	6.25	0.26	1.55	1.77	1.10	6.36	5.34	2.81	2.63	12.14	11.13	ns
8 mA	Std.	1.55	5.18	0.26	1.55	1.77	1.10	5.26	4.61	3.13	3.32	11.05	10.39	ns
12 mA	Std.	1.55	4.42	0.26	1.55	1.77	1.10	4.49	4.08	3.36	3.76	10.28	9.86	ns
16 mA	Std.	1.55	4.19	0.26	1.55	1.77	1.10	4.25	3.96	3.40	3.89	10.04	9.75	ns
24 mA	Std.	1.55	4.09	0.26	1.55	1.76	1.10	4.15	3.97	3.47	4.32	9.94	9.76	ns

*Note:* For specific junction temperature and voltage supply levels, refer to [Table 2-7 on page 2-6](#) for derating values.

**Table 2-51 • 2.5 V LVCMOS High Slew – Applies to 1.2 V DC Core Voltage**  
**Commercial-Case Conditions:  $T_J = 70^\circ\text{C}$ , Worst-Case VCC = 1.14 V, Worst-Case VCCI = 2.3 V**

Drive Strength	Speed Grade	$t_{DOUT}$	$t_{DP}$	$t_{DIN}$	$t_{PY}$	$t_{PYS}$	$t_{EOUT}$	$t_{ZL}$	$t_{ZH}$	$t_{LZ}$	$t_{HZ}$	$t_{ZLS}$	$t_{ZHS}$	Units
4 mA	Std.	1.55	3.38	0.26	1.55	1.77	1.10	3.42	3.11	2.81	2.72	9.21	8.89	ns
8 mA	Std.	1.55	2.83	0.26	1.55	1.77	1.10	2.87	2.51	3.13	3.42	8.66	8.30	ns
12 mA	Std.	1.55	2.51	0.26	1.55	1.77	1.10	2.54	2.22	3.36	3.85	8.33	8.00	ns
16 mA	Std.	1.55	2.45	0.26	1.55	1.77	1.10	2.48	2.16	3.40	3.97	8.27	7.95	ns
24 mA	Std.	1.55	2.46	0.26	1.55	1.77	1.10	2.49	2.09	3.47	4.44	8.28	7.88	ns

*Notes:*

1. Software default selection highlighted in gray.
2. For specific junction temperature and voltage supply levels, refer to [Table 2-7 on page 2-6](#) for derating values.

## 1.8 V LVCMOS

Low-Voltage CMOS for 1.8 V is an extension of the LVCMOS standard (JESD8-5) used for general-purpose 1.8 V applications. It uses a 1.8 V input buffer and a push-pull output buffer.

**Table 2-52 • Minimum and Maximum DC Input and Output Levels**

1.8 V LVCMOS	VIL		VIH		VOL	VOH	IOL	IOH	IOSH	IOSL	IIL <sup>1</sup>	IIH <sup>2</sup>
	Min. V	Max. V	Min. V	Max. V	Max. V	Min. V	mA	mA	Max. mA <sup>3</sup>	Max. mA <sup>3</sup>	μA <sup>4</sup>	μA <sup>4</sup>
2 mA	-0.3	0.35 * VCCI	0.65 * VCCI	3.6	0.45	VCCI - 0.45	2	2	9	11	10	10
4 mA	-0.3	0.35 * VCCI	0.65 * VCCI	3.6	0.45	VCCI - 0.45	4	4	17	22	10	10
6 mA	-0.3	0.35 * VCCI	0.65 * VCCI	3.6	0.45	VCCI - 0.45	6	6	35	44	10	10
8 mA	-0.3	0.35 * VCCI	0.65 * VCCI	3.6	0.45	VCCI - 0.45	8	8	45	51	10	10
12 mA	-0.3	0.35 * VCCI	0.65 * VCCI	3.6	0.45	VCCI - 0.45	12	12	91	74	10	10
16 mA	-0.3	0.35 * VCCI	0.65 * VCCI	3.6	0.45	VCCI - 0.45	16	16	91	74	10	10

**Notes:**

1. IIL is the input leakage current per I/O pin over recommended operation conditions where  $-0.3\text{ V} < V_{IN} < V_{IL}$ .
2. IIH is the input leakage current per I/O pin over recommended operating conditions  $V_{IH} < V_{IN} < V_{CCI}$ . Input current is larger when operating outside recommended ranges.
3. Currents are measured at high temperature (100°C junction temperature) and maximum voltage.
4. Currents are measured at 85°C junction temperature.
5. Software default selection highlighted in gray.

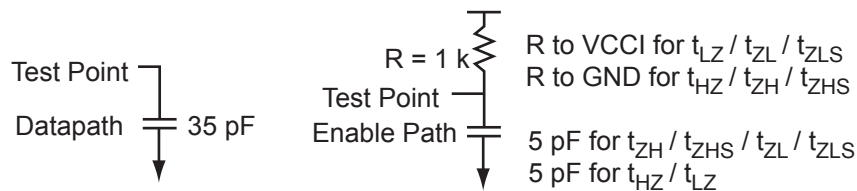

**Figure 2-9 • AC Loading**

**Table 2-53 • AC Waveforms, Measuring Points, and Capacitive Loads**

Input Low (V)	Input High (V)	Measuring Point* (V)	VREF (typ.) (V)	C <sub>LOAD</sub> (pF)
0	1.8	0.9	-	5

*Note:* \*Measuring point = Vtrip. See Table 2-23 on page 2-23 for a complete table of trip points.

## Timing Characteristics

### 1.5 V DC Core Voltage

**Table 2-54 • 1.8 V LVCMOS Low Slew – Applies to 1.5 V DC Core Voltage**  
 Commercial-Case Conditions:  $T_J = 70^\circ\text{C}$ , Worst-Case VCC = 1.425 V, Worst-Case VCCI = 1.7 V

Drive Strength	Speed Grade	$t_{DOUT}$	$t_{DP}$	$t_{DIN}$	$t_{PY}$	$t_{PYS}$	$t_{EOUT}$	$t_{ZL}$	$t_{ZH}$	$t_{LZ}$	$t_{HZ}$	$t_{ZLS}$	$t_{ZHS}$	Units
2 mA	Std.	0.97	7.33	0.18	1.27	1.59	0.66	7.47	6.18	2.34	1.18	11.07	9.77	ns
4 mA	Std.	0.97	6.07	0.18	1.27	1.59	0.66	6.20	5.25	2.69	2.42	9.79	8.84	ns
6 mA	Std.	0.97	5.18	0.18	1.27	1.59	0.66	5.29	4.61	2.93	2.88	8.88	8.21	ns
8 mA	Std.	0.97	4.88	0.18	1.27	1.59	0.66	4.98	4.48	2.99	3.01	8.58	8.08	ns
12 mA	Std.	0.97	4.80	0.18	1.27	1.59	0.66	4.89	4.49	3.07	3.47	8.49	8.09	ns
16 mA	Std.	0.97	4.80	0.18	1.27	1.59	0.66	4.89	4.49	3.07	3.47	8.49	8.09	ns

*Note:* For specific junction temperature and voltage supply levels, refer to [Table 2-6 on page 2-6](#) for derating values.

**Table 2-55 • 1.8 V LVCMOS High Slew – Applies to 1.5 V DC Core Voltage**  
 Commercial-Case Conditions:  $T_J = 70^\circ\text{C}$ , Worst-Case VCC = 1.425 V, Worst-Case VCCI = 1.7 V

Drive Strength	Speed Grade	$t_{DOUT}$	$t_{DP}$	$t_{DIN}$	$t_{PY}$	$t_{PYS}$	$t_{EOUT}$	$t_{ZL}$	$t_{ZH}$	$t_{LZ}$	$t_{HZ}$	$t_{ZLS}$	$t_{ZHS}$	Units
2 mA	Std.	0.97	3.43	0.18	1.27	1.59	0.66	3.51	3.39	2.33	1.19	7.10	6.98	ns
4 mA	Std.	0.97	2.83	0.18	1.27	1.59	0.66	2.89	2.59	2.69	2.49	6.48	6.18	ns
6 mA	Std.	0.97	2.45	0.18	1.27	1.59	0.66	2.51	2.19	2.93	2.95	6.10	5.79	ns
8 mA	Std.	0.97	2.38	0.18	1.27	1.59	0.66	2.43	2.12	2.98	3.08	6.03	5.71	ns
12 mA	Std.	0.97	2.37	0.18	1.27	1.59	0.66	2.42	2.03	3.07	3.57	6.02	5.62	ns
16 mA	Std.	0.97	2.37	0.18	1.27	1.59	0.66	2.42	2.03	3.07	3.57	6.02	5.62	ns

*Notes:*

1. Software default selection highlighted in gray.
2. For specific junction temperature and voltage supply levels, refer to [Table 2-6 on page 2-6](#) for derating values.

**1.2 V DC Core Voltage**
**Table 2-56 • 1.8 V LVCMOS Low Slew – Applies to 1.2 V DC Core Voltage**
**Commercial-Case Conditions:  $T_J = 70^\circ\text{C}$ , Worst-Case VCC = 1.14 V, Worst-Case VCCI = 1.7 V**

Drive Strength	Speed Grade	$t_{DOUT}$	$t_{DP}$	$t_{DIN}$	$t_{PY}$	$t_{PYS}$	$t_{EOUT}$	$t_{ZL}$	$t_{ZH}$	$t_{LZ}$	$t_{HZ}$	$t_{ZLS}$	$t_{ZHS}$	Units
2 mA	Std.	1.55	8.21	0.26	1.53	1.96	1.10	8.35	6.88	2.87	1.70	14.14	12.67	ns
4 mA	Std.	1.55	6.83	0.26	1.53	1.96	1.10	6.94	5.88	3.27	3.18	12.73	11.67	ns
6 mA	Std.	1.55	5.85	0.26	1.53	1.96	1.10	5.94	5.19	3.53	3.37	11.73	10.98	ns
8 mA	Std.	1.55	5.52	0.26	1.53	1.96	1.10	5.61	5.06	3.59	3.88	11.39	10.84	ns
12 mA	Std.	1.55	5.42	0.26	1.53	1.96	1.10	5.51	5.06	3.68	4.44	11.30	10.85	ns
16 mA	Std.	1.55	5.42	0.26	1.53	1.96	1.10	5.51	5.06	3.68	4.44	11.30	10.85	ns

Note: For specific junction temperature and voltage supply levels, refer to Table 2-7 on page 2-6 for derating values.

**Table 2-57 • 1.8 V LVCMOS High Slew – Applies to 1.2 V DC Core Voltage**
**Commercial-Case Conditions:  $T_J = 70^\circ\text{C}$ , Worst-Case VCC = 1.14 V, Worst-Case VCCI = 1.7 V**

Drive Strength	Speed Grade	$t_{DOUT}$	$t_{DP}$	$t_{DIN}$	$t_{PY}$	$t_{PYS}$	$t_{EOUT}$	$t_{ZL}$	$t_{ZH}$	$t_{LZ}$	$t_{HZ}$	$t_{ZLS}$	$t_{ZHS}$	Units
2 mA	Std.	1.55	3.82	0.26	1.53	1.96	1.10	3.98	3.87	2.86	1.72	9.76	9.66	ns
4 mA	Std.	1.55	3.25	0.26	1.53	1.96	1.10	3.30	3.01	3.26	3.26	9.08	8.79	ns
6 mA	Std.	1.55	2.84	0.26	1.53	1.96	1.10	2.88	2.58	3.53	3.81	8.66	8.37	ns
8 mA	Std.	1.55	2.76	0.26	1.53	1.96	1.10	2.80	2.50	3.58	3.97	8.58	8.29	ns
12 mA	Std.	1.55	2.75	0.26	1.53	1.96	1.10	2.78	2.40	3.68	4.56	8.57	8.19	ns
16 mA	Std.	1.55	2.75	0.26	1.53	1.96	1.10	2.78	2.40	3.68	4.56	8.57	8.19	ns

Notes:

1. Software default selection highlighted in gray.
2. For specific junction temperature and voltage supply levels, refer to Table 2-7 on page 2-6 for derating values.

### 1.5 V LVCMOS (JESD8-11)

Low-Voltage CMOS for 1.5 V is an extension of the LVCMOS standard (JESD8-5) used for general-purpose 1.5 V applications. It uses a 1.5 V input buffer and a push-pull output buffer.

**Table 2-58 • Minimum and Maximum DC Input and Output Levels**

1.5 V LVCMOS Drive Strength	VIL		VIH		VOL	VOH	IOL	IOH	IOSH	IOSL	IIL <sup>1</sup>	IIH <sup>2</sup>
	Min. V	Max. V	Min. V	Max. V	Max. V	Min. V	mA	mA	Max. mA <sup>3</sup>	Max. mA <sup>3</sup>	μA <sup>4</sup>	μA <sup>4</sup>
2 mA	-0.3	0.35 * VCCI	0.65 * VCCI	3.6	0.25 * VCCI	0.75 * VCCI	2	2	13	16	10	10
4 mA	-0.3	0.35 * VCCI	0.65 * VCCI	3.6	0.25 * VCCI	0.75 * VCCI	4	4	25	33	10	10
6 mA	-0.3	0.35 * VCCI	0.65 * VCCI	3.6	0.25 * VCCI	0.75 * VCCI	6	6	32	39	10	10
8 mA	-0.3	0.35 * VCCI	0.65 * VCCI	3.6	0.25 * VCCI	0.75 * VCCI	8	8	66	55	10	10
12 mA	-0.3	0.35 * VCCI	0.65 * VCCI	3.6	0.25 * VCCI	0.75 * VCCI	12	12	66	55	10	10

**Notes:**

1. IIL is the input leakage current per I/O pin over recommended operation conditions where  $-0.3\text{ V} < V_{IN} < V_{IL}$ .
2. IIH is the input leakage current per I/O pin over recommended operating conditions  $V_{IH} < V_{IN} < V_{CCI}$ . Input current is larger when operating outside recommended ranges.
3. Currents are measured at high temperature (100°C junction temperature) and maximum voltage.
4. Currents are measured at 85°C junction temperature.
5. Software default selection highlighted in gray.

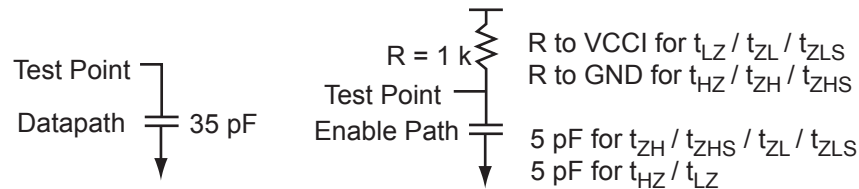

**Figure 2-10 • AC Loading**

**Table 2-59 • AC Waveforms, Measuring Points, and Capacitive Loads**

Input Low (V)	Input High (V)	Measuring Point* (V)	VREF (typ.) (V)	C <sub>LOAD</sub> (pF)
0	1.5	0.75	–	5

*Note:* \*Measuring point = Vtrip. See Table 2-23 on page 2-23 for a complete table of trip points.

## Timing Characteristics

### 1.5 V DC Core Voltage

**Table 2-60 • 1.5 V LVCMOS Low Slew – Applies to 1.5 V DC Core Voltage**

Commercial-Case Conditions:  $T_J = 70^\circ\text{C}$ , Worst-Case VCC = 1.425 V, Worst-Case VCCI = 1.4 V

Drive Strength	Speed Grade	t <sub>DOUT</sub>	t <sub>DP</sub>	t <sub>DIN</sub>	t <sub>PY</sub>	t <sub>PYS</sub>	t <sub>EOUT</sub>	t <sub>ZL</sub>	t <sub>ZH</sub>	t <sub>LZ</sub>	t <sub>HZ</sub>	t <sub>ZLS</sub>	t <sub>ZHS</sub>	Units
2 mA	Std.	0.97	7.61	0.18	1.47	1.77	0.66	7.76	6.33	2.81	2.34	11.36	9.92	ns
4 mA	Std.	0.97	6.54	0.18	1.47	1.77	0.66	6.67	5.56	3.09	2.88	10.26	9.16	ns
6 mA	Std.	0.97	6.15	0.18	1.47	1.77	0.66	6.27	5.42	3.15	3.02	9.87	9.02	ns
8 mA	Std.	0.97	6.07	0.18	1.47	1.77	0.66	6.20	5.42	2.64	3.56	9.79	9.02	ns
12 mA	Std.	0.97	6.07	0.18	1.47	1.77	0.66	6.20	5.42	2.64	3.56	9.79	9.02	ns

Note: For specific junction temperature and voltage supply levels, refer to Table 2-6 on page 2-6 for derating values.

**Table 2-61 • 1.5 V LVCMOS High Slew – Applies to 1.5 V DC Core Voltage**

Commercial-Case Conditions:  $T_J = 70^\circ\text{C}$ , Worst-Case VCC = 1.425 V, Worst-Case VCCI = 1.4 V

Drive Strength	Speed Grade	t <sub>DOUT</sub>	t <sub>DP</sub>	t <sub>DIN</sub>	t <sub>PY</sub>	t <sub>PYS</sub>	t <sub>EOUT</sub>	t <sub>ZL</sub>	t <sub>ZH</sub>	t <sub>LZ</sub>	t <sub>HZ</sub>	t <sub>ZLS</sub>	t <sub>ZHS</sub>	Units
2 mA	Std.	0.97	3.25	0.18	1.47	1.77	0.66	3.32	3.00	2.80	2.43	6.92	6.59	ns
4 mA	Std.	0.97	2.81	0.18	1.47	1.77	0.66	2.87	2.51	3.08	2.97	6.46	6.10	ns
6 mA	Std.	0.97	2.72	0.18	1.47	1.77	0.66	2.78	2.41	3.14	3.12	6.37	6.01	ns
8 mA	Std.	0.97	2.69	0.18	1.47	1.77	0.66	2.75	2.30	3.24	3.67	6.35	5.89	ns
12 mA	Std.	0.97	2.69	0.18	1.47	1.77	0.66	2.75	2.30	3.24	3.67	6.35	5.89	ns

Notes:

1. Software default selection highlighted in gray.
2. For specific junction temperature and voltage supply levels, refer to Table 2-6 on page 2-6 for derating values.

### 1.2 V DC Core Voltage

**Table 2-62 • 1.5 V LVCMOS Low Slew – Applies to 1.2 V DC Core Voltage**  
 Commercial-Case Conditions:  $T_J = 70^\circ\text{C}$ , Worst-Case VCC = 1.14 V, Worst-Case VCCI = 1.4 V

Drive Strength	Speed Grade	$t_{DOUT}$	$t_{DP}$	$t_{DIN}$	$t_{PY}$	$t_{PYS}$	$t_{EOUT}$	$t_{ZL}$	$t_{ZH}$	$t_{LZ}$	$t_{HZ}$	$t_{ZLS}$	$t_{ZHS}$	Units
2 mA	Std.	1.55	8.53	0.26	1.72	2.16	1.10	8.67	7.05	3.39	3.09	14.46	12.83	ns
4 mA	Std.	1.55	7.34	0.26	1.72	2.16	1.10	7.46	6.22	3.70	3.73	13.25	12.01	ns
6 mA	Std.	1.55	6.91	0.26	1.72	2.16	1.10	7.03	6.07	3.77	3.90	12.82	11.85	ns
8 mA	Std.	1.55	6.83	0.26	1.72	2.16	1.10	6.94	6.07	2.91	4.54	12.73	11.86	ns
12 mA	Std.	1.55	6.83	0.26	1.72	2.16	1.10	6.94	6.07	2.91	4.54	12.73	11.86	ns

*Note:* For specific junction temperature and voltage supply levels, refer to [Table 2-7 on page 2-6](#) for derating values.

**Table 2-63 • 1.5 V LVCMOS High Slew – Applies to 1.2 V DC Core Voltage**  
 Commercial-Case Conditions:  $T_J = 70^\circ\text{C}$ , Worst-Case VCC = 1.14 V, Worst-Case VCCI = 1.4 V

Drive Strength	Speed Grade	$t_{DOUT}$	$t_{DP}$	$t_{DIN}$	$t_{PY}$	$t_{PYS}$	$t_{EOUT}$	$t_{ZL}$	$t_{ZH}$	$t_{LZ}$	$t_{HZ}$	$t_{ZLS}$	$t_{ZHS}$	Units
2 mA	Std.	1.55	3.72	0.26	1.72	2.16	1.10	3.78	3.45	3.38	3.19	9.56	9.24	ns
4 mA	Std.	1.55	3.23	0.26	1.72	2.16	1.10	3.27	2.92	3.69	3.83	9.06	8.71	ns
6 mA	Std.	1.55	3.13	0.26	1.72	2.16	1.10	3.18	2.82	3.76	4.01	8.96	8.61	ns
8 mA	Std.	1.55	3.10	0.26	1.72	2.16	1.10	3.15	2.70	3.86	4.68	8.93	8.49	ns
12 mA	Std.	1.55	3.10	0.26	1.72	2.16	1.10	3.15	2.70	3.86	4.68	8.93	8.49	ns

*Notes:*

1. Software default selection highlighted in gray.
2. For specific junction temperature and voltage supply levels, refer to [Table 2-7 on page 2-6](#) for derating values.

### 1.2 V LVCMOS (JESD8-12A)

Low-Voltage CMOS for 1.2 V complies with the LVCMOS standard JESD8-12A for general purpose 1.2 V applications. It uses a 1.2 V input buffer and a push-pull output buffer.

**Table 2-64 • Minimum and Maximum DC Input and Output Levels**  
Applicable to Advanced I/O Banks

1.2 V LVCMOS <sup>1</sup>	VIL		VIH		VOL	VOH	IOL	IOH	IOSH	IOSL	IIL <sup>2</sup>	IIH <sup>3</sup>
	Min. V	Max. V	Min. V	Max. V	Max. V	Min. V	mA	mA	Max. mA <sup>4</sup>	Max. mA <sup>4</sup>	μA <sup>5</sup>	μA <sup>5</sup>
2 mA	-0.3	0.35 * VCCI	0.65 * VCCI	3.6	0.25 * VCCI	0.75 * VCCI	2	2	20	26	10	10

**Notes:**

1. Applicable to V2 devices ONLY.
2. IIL is the input leakage current per I/O pin over recommended operation conditions where  $-0.3\text{ V} < V_{IN} < V_{IL}$ .
3. IIH is the input leakage current per I/O pin over recommended operating conditions  $V_{IH} < V_{IN} < V_{CCI}$ . Input current is larger when operating outside recommended ranges.
4. Currents are measured at high temperature (100°C junction temperature) and maximum voltage.
5. Currents are measured at 85°C junction temperature.
6. Software default selection highlighted in gray.

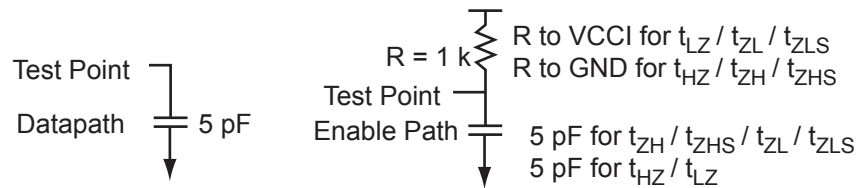

**Figure 2-11 • AC Loading**

**Table 2-65 • AC Waveforms, Measuring Points, and Capacitive Loads**

Input Low (V)	Input High (V)	Measuring Point* (V)	VREF (typ.) (V)	C <sub>LOAD</sub> (pF)
0	1.2	0.6	-	5

Note: \*Measuring point = V<sub>trip</sub>. See Table 2-23 on page 2-23 for a complete table of trip points.

## Timing Characteristics

### 1.2 V DC Core Voltage

**Table 2-66 • 1.2 LVCMOS Low Slew – Applies to 1.2 V DC Core Voltage**  
 Commercial-Case Conditions:  $T_J = 70^\circ\text{C}$ , Worst-Case VCC = 1.14 V, Worst-Case VCCI = 1.14 V

Drive Strength	Speed Grade	$t_{DOUT}$	$t_{DP}$	$t_{DIN}$	$t_{PY}$	$t_{PYS}$	$t_{EOUT}$	$t_{ZL}$	$t_{ZH}$	$t_{LZ}$	$t_{HZ}$	$t_{ZLS}$	$t_{ZHS}$	Units
2 mA	Std.	1.55	9.92	0.26	2.09	2.95	1.10	9.53	7.48	4.02	3.67	15.31	13.26	ns

**Notes:**

1. Software default selection highlighted in gray.
2. For specific junction temperature and voltage supply levels, refer to [Table 2-7 on page 2-6](#) for derating values.

**Table 2-67 • 1.2 LVCMOS High Slew – Applies to 1.2 V DC Core Voltage**  
 Commercial-Case Conditions:  $T_J = 70^\circ\text{C}$ , Worst-Case VCC = 1.14 V, Worst-Case VCCI = 1.14 V

Drive Strength	Speed Grade	$t_{DOUT}$	$t_{DP}$	$t_{DIN}$	$t_{PY}$	$t_{PYS}$	$t_{EOUT}$	$t_{ZL}$	$t_{ZH}$	$t_{LZ}$	$t_{HZ}$	$t_{ZLS}$	$t_{ZHS}$	Units
2 mA	Std.	1.55	4.06	0.26	2.09	2.95	1.10	3.92	3.46	4.01	3.79	9.71	9.24	ns

**Notes:**

1. Software default selection highlighted in gray.
2. For specific junction temperature and voltage supply levels, refer to [Table 2-7 on page 2-6](#) for derating values.

### 1.2 V LVCMOS Wide Range

**Table 2-68 • Minimum and Maximum DC Input and Output Levels**

1.2 V LVCMOS Wide Range <sup>1</sup>		VIL		VIH		VOL	VOH	IOL	IOH	IOSH	IOSL	IIL <sup>2</sup>	IIH <sup>3</sup>
Drive Strength	Equivalent Software Default Drive Strength Option <sup>4</sup>	Min. (V)	Max. (V)	Min. (V)	Max (V)	Max. (V)	Min. (V)	$\mu\text{A}$	$\mu\text{A}$	Max. (mA) <sup>5</sup>	Max. (mA) <sup>5</sup>	$\mu\text{A}$ <sup>6</sup>	$\mu\text{A}$ <sup>6</sup>
100 $\mu\text{A}$	2 mA	-0.3	0.35 * VCCI	0.65 * VCCI	3.6	0.25 * VCCI	0.75 * VCCI	100	100	20	26	10	10

**Notes:**

1. Applicable to V2 devices ONLY.
2. IIL is the input leakage current per I/O pin over recommended operation conditions where  $-0.3\text{ V} < V_{IN} < V_{IL}$ .
3. IIH is the input leakage current per I/O pin over recommended operating conditions  $V_{IH} < V_{IN} < V_{CCI}$ . Input current is larger when operating outside recommended ranges.
4. The minimum drive strength for any LVCMOS 1.2 V software configuration when run in wide range is  $\pm 100\ \mu\text{A}$ . Drive strength displayed in the software is supported for normal range only. For a detailed I/V curve, refer to the IBIS models.
5. Currents are measured at high temperature ( $100^\circ\text{C}$  junction temperature) and maximum voltage.
6. Currents are measured at  $85^\circ\text{C}$  junction temperature.
7. Software default selection highlighted in gray.

## Timing Characteristics

Refer to LVCMOS 1.2 V (normal range) "Timing Characteristics" on page 2-48 for worst-case timing.

### 3.3 V PCI, 3.3 V PCI-X

Peripheral Component Interface for 3.3 V standard specifies support for 33 MHz and 66 MHz PCI Bus applications.

**Table 2-69 • Minimum and Maximum DC Input and Output Levels**

3.3 V PCI/PCI-X	VIL		VIH		VOL	VOH	IOL	IOH	IOSH	IOSL	IIL <sup>1</sup>	IIH <sup>2</sup>
	Min. V	Max. V	Min. V	Max. V	Max. V	Min. V	mA	mA	Max. mA <sup>3</sup>	Max. mA <sup>3</sup>	μA <sup>4</sup>	μA <sup>4</sup>
Per PCI specification	Per PCI curves										10	10

**Notes:**

1. IIL is the input leakage current per I/O pin over recommended operation conditions where  $-0.3\text{ V} < V_{IN} < V_{IL}$ .
2. IIH is the input leakage current per I/O pin over recommended operating conditions  $V_{IH} < V_{IN} < V_{CCI}$ . Input current is larger when operating outside recommended ranges.
3. Currents are measured at high temperature (100°C junction temperature) and maximum voltage.
4. Currents are measured at 85°C junction temperature.

AC loadings are defined per the PCI/PCI-X specifications for the datapath; Microsemi loadings for enable path characterization are described in [Figure 2-12](#).

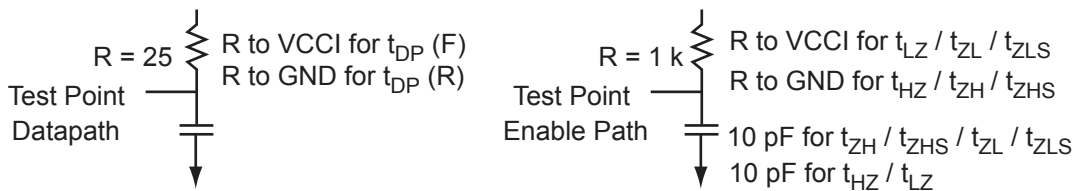

**Figure 2-12 • AC Loading**

AC loadings are defined per PCI/PCI-X specifications for the datapath; Microsemi loading for tristate is described in [Table 2-70](#).

**Table 2-70 • AC Waveforms, Measuring Points, and Capacitive Loads**

Input Low (V)	Input High (V)	Measuring Point* (V)	VREF (typ.) (V)	C <sub>LOAD</sub> (pF)
0	3.3	0.285 * VCCI for t <sub>DP(R)</sub> 0.615 * VCCI for t <sub>DP(F)</sub>	–	10

*Note:* \*Measuring point = Vtrip. See [Table 2-23 on page 2-23](#) for a complete table of trip points.

### Timing Characteristics

#### 1.5 V DC Core Voltage

**Table 2-71 • 3.3 V PCI/PCI-X – Applies to 1.5 V DC Core Voltage**
**Commercial-Case Conditions:  $T_J = 70^\circ\text{C}$ , Worst-Case VCC = 1.425 V, Worst-Case VCCI = 3.0 V**

Speed Grade	$t_{DOUT}$	$t_{DP}$	$t_{DIN}$	$t_{PY}$	$t_{PYS}$	$t_{EOUT}$	$t_{ZL}$	$t_{ZH}$	$t_{LZ}$	$t_{HZ}$	$t_{ZLS}$	$t_{ZHS}$	Units
Std.	0.97	2.38	0.18	0.96	1.42	0.66	2.43	1.80	2.72	3.08	6.03	5.39	ns

*Note:* For specific junction temperature and voltage supply levels, refer to [Table 2-6 on page 2-6](#) for derating values.

#### 1.2 V DC Core Voltage

**Table 2-72 • 3.3 V PCI/PCI-X – Applies to 1.2 V DC Core Voltage**
**Commercial-Case Conditions:  $T_J = 70^\circ\text{C}$ , Worst-Case VCC = 1.14 V, Worst-Case VCCI = 3.0 V**

Speed Grade	$t_{DOUT}$	$t_{DP}$	$t_{DIN}$	$t_{PY}$	$t_{PYS}$	$t_{EOUT}$	$t_{ZL}$	$t_{ZH}$	$t_{LZ}$	$t_{HZ}$	$t_{ZLS}$	$t_{ZHS}$	Units
Std.	1.55	2.76	0.26	1.19	1.63	1.10	2.79	2.16	3.29	3.97	8.58	7.94	ns

*Note:* For specific junction temperature and voltage supply levels, refer to [Table 2-7 on page 2-6](#) for derating values.

## Voltage-Referenced I/O Characteristics

### 3.3 V GTL

Gunning Transceiver Logic is a high-speed bus standard (JESD8-3). It provides a differential amplifier input buffer and an open-drain output buffer. The VCCI pin should be connected to 3.3 V.

**Table 2-73 • Minimum and Maximum DC Input and Output Levels**

3.3 V GTL Drive Strength	VIL		VIH		VOL	VOH	IOL	IOH	IOSL	IOSH	IIL <sup>1</sup>	IIH <sup>2</sup>
	Min. V	Max. V	Min. V	Max. V	Max V	Min. V	mA	mA	Max. mA <sup>3</sup>	Max. mA <sup>3</sup>	μA <sup>4</sup>	μA <sup>4</sup>
20 mA <sup>5</sup>	-0.3	VREF - 0.05	VREF + 0.05	3.6	0.4	-	20	20	268	181	10	10

**Notes:**

1. IIL is the input leakage current per I/O pin over recommended operating conditions where  $-0.3\text{ V} < V_{IN} < V_{IL}$ .
2. IIH is the input leakage current per I/O pin over recommended operating conditions  $V_{IH} < V_{IN} < V_{CCI}$ . Input current is larger when operating outside recommended ranges.
3. Currents are measured at high temperature (100°C junction temperature) and maximum voltage.
4. Currents are measured at 85°C junction temperature.
5. Output drive strength is below JEDEC specification.

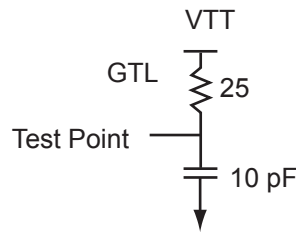

**Figure 2-13 • AC Loading**

**Table 2-74 • AC Waveforms, Measuring Points, and Capacitive Loads**

Input Low (V)	Input High (V)	Measuring Point* (V)	VREF (typ.) (V)	VTT (typ.) (V)	C <sub>LOAD</sub> (pF)
VREF - 0.05	VREF + 0.05	0.8	0.8	1.2	10

*Note:* \*Measuring point = Vtrip. See Table 2-23 on page 2-23 for a complete table of trip points.

### Timing Characteristics

#### 1.5 V DC Core Voltage

**Table 2-75 • 3.3 V GTL – Applies to 1.5 V DC Core Voltage**  
**Commercial-Case Conditions:  $T_J = 70^\circ\text{C}$ , Worst-Case  $V_{CC} = 1.425\text{ V}$ ,**  
**Worst-Case  $V_{CCI} = 3.0\text{ V}$   $V_{REF} = 0.8\text{ V}$**

Speed Grade	$t_{DOUT}$	$t_{DP}$	$t_{DIN}$	$t_{PY}$	$t_{EOUT}$	$t_{ZL}$	$t_{ZH}$	$t_{LZ}$	$t_{HZ}$	$t_{ZLS}$	$t_{ZHS}$	Units
Std.	0.98	1.83	0.19	2.41	0.67	1.84	1.83			5.47	5.46	ns

*Note:* For specific junction temperature and voltage supply levels, refer to [Table 2-6 on page 2-6](#) for derating values.

#### 1.2 V DC Core Voltage

**Table 2-76 • 3.3 V GTL – Applies to 1.2 V DC Core Voltage**  
**Commercial-Case Conditions:  $T_J = 70^\circ\text{C}$ , Worst-Case  $V_{CC} = 1.14\text{ V}$ ,**  
**Worst-Case  $V_{CCI} = 3.0\text{ V}$   $V_{REF} = 0.8\text{ V}$**

Speed Grade	$t_{DOUT}$	$t_{DP}$	$t_{DIN}$	$t_{PY}$	$t_{EOUT}$	$t_{ZL}$	$t_{ZH}$	$t_{LZ}$	$t_{HZ}$	$t_{ZLS}$	$t_{ZHS}$	Units
Std.	1.55	2.09	0.26	2.75	1.10	2.10	2.09			7.91	7.89	ns

*Note:* For specific junction temperature and voltage supply levels, refer to [Table 2-7 on page 2-6](#) for derating values.

## 2.5 V GTL

Gunning Transceiver Logic is a high-speed bus standard (JESD8-3). It provides a differential amplifier input buffer and an open-drain output buffer. The VCCI pin should be connected to 2.5 V.

**Table 2-77 • Minimum and Maximum DC Input and Output Levels**

2.5 GTL Drive Strength	VIL		VIH		VOL	VOH	IOL	IOH	IOSH	IOSL	IIL <sup>1</sup>	IIH <sup>2</sup>
	Min. V	Max. V	Min. V	Max. V	Max. V	Min. V	mA	mA	Max. mA <sup>3</sup>	Max. mA <sup>3</sup>	μA <sup>4</sup>	μA <sup>4</sup>
20 mA <sup>5</sup>	-0.3	VREF - 0.05	VREF + 0.05	3.6	0.4	-	20	20	169	124	10	10

**Notes:**

1. IIL is the input leakage current per I/O pin over recommended operating conditions where  $-0.3\text{ V} < V_{IN} < V_{IL}$ .
2. IIH is the input leakage current per I/O pin over recommended operating conditions  $V_{IH} < V_{IN} < V_{CCI}$ . Input current is larger when operating outside recommended ranges.
3. Currents are measured at high temperature (100°C junction temperature) and maximum voltage.
4. Currents are measured at 85°C junction temperature.
5. Output drive strength is below JEDEC specification.

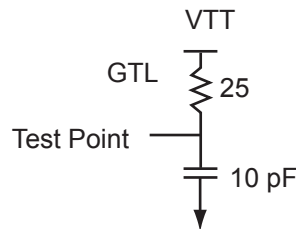

**Figure 2-14 • AC Loading**

**Table 2-78 • AC Waveforms, Measuring Points, and Capacitive Loads**

Input Low (V)	Input High (V)	Measuring Point* (V)	VREF (typ.) (V)	VTT (typ.) (V)	C <sub>LOAD</sub> (pF)
VREF - 0.05	VREF + 0.05	0.8	0.8	1.2	10

*Note:* \*Measuring point = Vtrip. See Table 2-23 on page 2-23 for a complete table of trip points.

### Timing Characteristics

#### 1.5 V DC Core Voltage

**Table 2-79 • 2.5 V GTL – Applies to 1.5 V DC Core Voltage**  
Commercial-Case Conditions: T<sub>J</sub> = 70°C, Worst-Case VCC = 1.425 V,  
Worst-Case VCCI = 3.0 V VREF = 0.8 V

Speed Grade	t <sub>DOUT</sub>	t <sub>DP</sub>	t <sub>DIN</sub>	t <sub>PY</sub>	t <sub>EOUT</sub>	t <sub>ZL</sub>	t <sub>ZH</sub>	t <sub>LZ</sub>	t <sub>HZ</sub>	t <sub>ZLS</sub>	t <sub>ZHS</sub>	Units
Std.	0.98	1.90	0.19	2.04	0.67	1.94	1.87			5.57	5.50	ns

*Note:* For specific junction temperature and voltage supply levels, refer to Table 2-6 on page 2-6 for derating values.

#### 1.2 V DC Core Voltage

**Table 2-80 • 2.5 V GTL – Applies to 1.2 V DC Core Voltage**  
Commercial-Case Conditions: T<sub>J</sub> = 70°C, Worst-Case VCC = 1.14 V,  
Worst-Case VCCI = 3.0 V VREF = 0.8 V

Speed Grade	t <sub>DOUT</sub>	t <sub>DP</sub>	t <sub>DIN</sub>	t <sub>PY</sub>	t <sub>EOUT</sub>	t <sub>ZL</sub>	t <sub>ZH</sub>	t <sub>LZ</sub>	t <sub>HZ</sub>	t <sub>ZLS</sub>	t <sub>ZHS</sub>	Units
Std.	1.55	2.16	0.26	2.35	1.10	2.20	2.13			8.01	7.94	ns

*Note:* For specific junction temperature and voltage supply levels, refer to Table 2-7 on page 2-6 for derating values.

### 3.3 V GTL+

Gunning Transceiver Logic Plus is a high-speed bus standard (JESD8-3). It provides a differential amplifier input buffer and an open-drain output buffer. The VCCI pin should be connected to 3.3 V

**Table 2-81 • Minimum and Maximum DC Input and Output Levels**

3.3 V GTL+	VIL		VIH		VOL	VOH	IOL	IOH	IOSH	IOSL	IIL <sup>1</sup>	IIH <sup>2</sup>
Drive Strength	Min. V	Max. V	Min. V	Max. V	Max. V	Min. V	mA	mA	Max. mA <sup>3</sup>	Max. mA <sup>3</sup>	μA <sup>4</sup>	μA <sup>4</sup>
35 mA	-0.3	VREF - 0.1	VREF + 0.1	3.6	0.6	-	35	35	268	181	10	10

**Notes:**

1. IIL is the input leakage current per I/O pin over recommended operating conditions where  $-0.3\text{ V} < V_{IN} < V_{IL}$ .
2. IIH is the input leakage current per I/O pin over recommended operating conditions  $V_{IH} < V_{IN} < V_{CCI}$ . Input current is larger when operating outside recommended ranges.
3. Currents are measured at high temperature (100°C junction temperature) and maximum voltage.
4. Currents are measured at 85°C junction temperature.

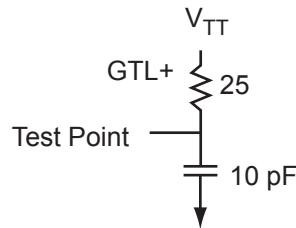

**Figure 2-15 • AC Loading**

**Table 2-82 • AC Waveforms, Measuring Points, and Capacitive Loads**

Input Low (V)	Input High (V)	Measuring Point* (V)	VREF (typ.) (V)	VTT (typ.) (V)	C <sub>LOAD</sub> (pF)
VREF - 0.1	VREF + 0.1	1.0	1.0	1.5	10

Note: \*Measuring point = Vtrip. See Table 2-23 on page 2-23 for a complete table of trip points.

### Timing Characteristics

#### 1.5 V DC Core Voltage

**Table 2-83 • 3.3 V GTL+ – Applies to 1.5 V DC Core Voltage**  
Commercial-Case Conditions: T<sub>J</sub> = 70°C, Worst-Case VCC = 1.425 V,  
Worst-Case VCCI = 3.0 V VREF = 1.0 V

Speed Grade	t <sub>DOUT</sub>	t <sub>DP</sub>	t <sub>DIN</sub>	t <sub>PY</sub>	t <sub>EOUT</sub>	t <sub>ZL</sub>	t <sub>ZH</sub>	t <sub>LZ</sub>	t <sub>HZ</sub>	t <sub>ZLS</sub>	t <sub>ZHS</sub>	Units
Std.	0.98	1.85	0.19	1.35	0.67	1.88	1.81			5.51	5.44	ns

Note: For specific junction temperature and voltage supply levels, refer to Table 2-6 on page 2-6 for derating values.

#### 1.2 V DC Core Voltage

**Table 2-84 • 3.3 V GTL+ – Applies to 1.2 V DC Core Voltage**  
Commercial-Case Conditions: T<sub>J</sub> = 70°C, Worst-Case VCC = 1.14 V,  
Worst-Case VCCI = 3.0 V VREF = 1.0 V

Speed Grade	t <sub>DOUT</sub>	t <sub>DP</sub>	t <sub>DIN</sub>	t <sub>PY</sub>	t <sub>EOUT</sub>	t <sub>ZL</sub>	t <sub>ZH</sub>	t <sub>LZ</sub>	t <sub>HZ</sub>	t <sub>ZLS</sub>	t <sub>ZHS</sub>	Units
Std.	1.55	2.11	0.26	1.61	1.10	2.15	2.07			7.95	7.88	ns

Note: For specific junction temperature and voltage supply levels, refer to Table 2-7 on page 2-6 for derating values.

## 2.5 V GTL+

Gunning Transceiver Logic Plus is a high-speed bus standard (JESD8-3). It provides a differential amplifier input buffer and an open-drain output buffer. The VCCI pin should be connected to 2.5 V.

**Table 2-85 • Minimum and Maximum DC Input and Output Levels**

2.5 V GTL+	VIL		VIH		VOL	VOH	IOL	IOH	IOSH	IOSL	IIL <sup>1</sup>	IIH <sup>2</sup>
	Min. V	Max. V	Min. V	Max. V	Max. V	Min. V	mA	mA	Max. mA <sup>3</sup>	Max. mA <sup>3</sup>	μA <sup>4</sup>	μA <sup>4</sup>
33 mA	-0.3	VREF - 0.1	VREF + 0.1	3.6	0.6	-	33	33	169	124	10	10

**Notes:**

1. IIL is the input leakage current per I/O pin over recommended operating conditions where  $-0.3\text{ V} < V_{IN} < V_{IL}$ .
2. IIH is the input leakage current per I/O pin over recommended operating conditions  $V_{IH} < V_{IN} < V_{CCI}$ . Input current is larger when operating outside recommended ranges.
3. Currents are measured at high temperature (100°C junction temperature) and maximum voltage.
4. Currents are measured at 85°C junction temperature.

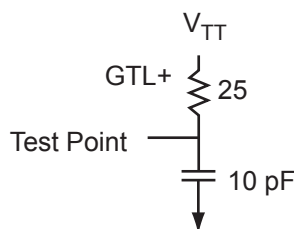

**Figure 2-16 • AC Loading**

**Table 2-86 • AC Waveforms, Measuring Points, and Capacitive Loads**

Input Low (V)	Input High (V)	Measuring Point* (V)	VREF (typ.) (V)	VTT (typ.) (V)	C <sub>LOAD</sub> (pF)
VREF - 0.1	VREF + 0.1	1.0	1.0	1.5	10

Note: \*Measuring point = Vtrip. See Table 2-23 on page 2-23 for a complete table of trip points.

### Timing Characteristics

#### 1.5 V DC Core Voltage

**Table 2-87 • 2.5 V GTL+ – Applies to 1.5 V DC Core Voltage**

Commercial-Case Conditions:  $T_J = 70^\circ\text{C}$ , Worst-Case VCC = 1.425 V,  
Worst-Case VCCI = 2.3 V VREF = 1.0 V

Speed Grade	t <sub>DOUT</sub>	t <sub>DP</sub>	t <sub>DIN</sub>	t <sub>PY</sub>	t <sub>EOUT</sub>	t <sub>ZL</sub>	t <sub>ZH</sub>	t <sub>LZ</sub>	t <sub>HZ</sub>	t <sub>ZLS</sub>	t <sub>ZHS</sub>	Units
Std.	0.98	1.97	0.19	1.29	0.67	2.00	1.84			5.63	5.47	ns

Note: For specific junction temperature and voltage supply levels, refer to Table 2-6 on page 2-6 for derating values.

#### 1.2 V DC Core Voltage

**Table 2-88 • 2.5 V GTL+ – Applies to 1.2 V DC Core Voltage**

Commercial-Case Conditions:  $T_J = 70^\circ\text{C}$ , Worst-Case VCC = 1.14 V,  
Worst-Case VCCI = 2.3 V VREF = 1.0 V

Speed Grade	t <sub>DOUT</sub>	t <sub>DP</sub>	t <sub>DIN</sub>	t <sub>PY</sub>	t <sub>EOUT</sub>	t <sub>ZL</sub>	t <sub>ZH</sub>	t <sub>LZ</sub>	t <sub>HZ</sub>	t <sub>ZLS</sub>	t <sub>ZHS</sub>	Units
Std.	1.55	2.23	0.26	1.55	1.10	2.28	2.11			8.08	7.91	ns

Note: For specific junction temperature and voltage supply levels, refer to Table 2-7 on page 2-6 for derating values.

## HSTL Class I

High-Speed Transceiver Logic is a general-purpose high-speed 1.5 V bus standard (EIA/JESD8-6). IGLOOe devices support Class I. This provides a differential amplifier input buffer and a push-pull output buffer.

**Table 2-89 • Minimum and Maximum DC Input and Output Levels**

HSTL Class I	VIL		VIH		VOL	VOH	IOL	IOH	IOSH	IOSL	IIL <sup>1</sup>	IIH <sup>2</sup>
	Min. V	Max. V	Min. V	Max. V	Max. V	Min. V	mA	mA	Max. mA <sup>3</sup>	Max. mA <sup>3</sup>	μA <sup>4</sup>	μA <sup>4</sup>
8 mA	-0.3	VREF - 0.1	VREF + 0.1	3.6	0.4	VCCI - 0.4	8	8	32	39	10	10

**Notes:**

1. IIL is the input leakage current per I/O pin over recommended operating conditions where  $-0.3\text{ V} < V_{IN} < V_{IL}$ .
2. IIH is the input leakage current per I/O pin over recommended operating conditions  $V_{IH} < V_{IN} < V_{CCI}$ . Input current is larger when operating outside recommended ranges.
3. Currents are measured at high temperature (100°C junction temperature) and maximum voltage.
4. Currents are measured at 85°C junction temperature.

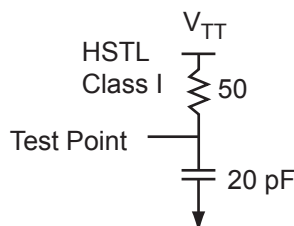

**Figure 2-17 • AC Loading**

**Table 2-90 • AC Waveforms, Measuring Points, and Capacitive Loads**

Input Low (V)	Input High (V)	Measuring Point* (V)	VREF (typ.) (V)	VTT (typ.) (V)	C <sub>LOAD</sub> (pF)
VREF - 0.1	VREF + 0.1	0.75	0.75	0.75	20

*Note:* \*Measuring point = Vtrip. See Table 2-23 on page 2-23 for a complete table of trip points.

## Timing Characteristics

### 1.5 V DC Core Voltage

**Table 2-91 • HSTL Class I – Applies to 1.5 V DC Core Voltage**

Commercial-Case Conditions:  $T_J = 70^\circ\text{C}$ , Worst-Case VCC = 1.425 V,  
Worst-Case VCCI = 1.4 V VREF = 0.75 V

Speed Grade	t <sub>DOUT</sub>	t <sub>DP</sub>	t <sub>DIN</sub>	t <sub>PY</sub>	t <sub>EOUT</sub>	t <sub>ZL</sub>	t <sub>ZH</sub>	t <sub>LZ</sub>	t <sub>HZ</sub>	t <sub>ZLS</sub>	t <sub>ZHS</sub>	Units
Std.	0.98	2.74	0.19	1.77	0.67	2.79	2.73			6.42	6.36	ns

*Note:* For specific junction temperature and voltage supply levels, refer to Table 2-6 on page 2-6 for derating values.

### 1.2 V DC Core Voltage

**Table 2-92 • HSTL Class I – Applies to 1.2 V DC Core Voltage**

Commercial-Case Conditions:  $T_J = 70^\circ\text{C}$ , Worst-Case VCC = 1.14 V,  
Worst-Case VCCI = 1.4 V VREF = 0.75 V

Speed Grade	t <sub>DOUT</sub>	t <sub>DP</sub>	t <sub>DIN</sub>	t <sub>PY</sub>	t <sub>EOUT</sub>	t <sub>ZL</sub>	t <sub>ZH</sub>	t <sub>LZ</sub>	t <sub>HZ</sub>	t <sub>ZLS</sub>	t <sub>ZHS</sub>	Units
Std.	1.55	3.10	0.26	1.94	1.10	3.12	3.10			8.93	8.91	ns

*Note:* For specific junction temperature and voltage supply levels, refer to Table 2-7 on page 2-6 for derating values.

## HSTL Class II

High-Speed Transceiver Logic is a general-purpose high-speed 1.5 V bus standard (EIA/JESD8-6). IGLOOe devices support Class II. This provides a differential amplifier input buffer and a push-pull output buffer.

**Table 2-93 • Minimum and Maximum DC Input and Output Levels**

HSTL Class II	VIL		VIH		VOL	VOH	IOL	IOH	IOSH	IOSL	III <sup>1</sup>	IIH <sup>2</sup>
	Min. V	Max. V	Min. V	Max. V	Max. V	Min. V	mA	mA	Max. mA <sup>3</sup>	Max. mA <sup>3</sup>	μA <sup>4</sup>	μA <sup>4</sup>
15 mA <sup>5</sup>	-0.3	VREF - 0.1	VREF + 0.1	3.6	0.4	VCCI - 0.4	15	15	66	55	10	10

**Notes:**

1. III is the input leakage current per I/O pin over recommended operating conditions where  $-0.3\text{ V} < V_{IN} < V_{IL}$ .
2. IIH is the input leakage current per I/O pin over recommended operating conditions  $V_{IH} < V_{IN} < V_{CCI}$ . Input current is larger when operating outside recommended ranges.
3. Currents are measured at high temperature (100°C junction temperature) and maximum voltage.
4. Currents are measured at 85°C junction temperature.
5. Output drive strength is below JEDEC specification.

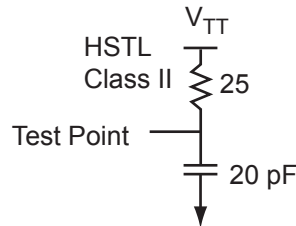

**Figure 2-18 • AC Loading**

**Table 2-94 • AC Waveforms, Measuring Points, and Capacitive Loads**

Input Low (V)	Input High (V)	Measuring Point* (V)	VREF (typ.) (V)	VTT (typ.) (V)	C <sub>LOAD</sub> (pF)
VREF - 0.1	VREF + 0.1	0.75	0.75	0.75	20

Note: \*Measuring point = Vtrip. See Table 2-23 on page 2-23 for a complete table of trip points.

### Timing Characteristics

#### 1.5 V DC Core Voltage

**Table 2-95 • HSTL Class II – Applies to 1.5 V DC Core Voltage**  
Commercial-Case Conditions: T<sub>J</sub> = 70°C, Worst-Case VCC = 1.425 V,  
Worst-Case VCCI = 1.4 V VREF = 0.75 V

Speed Grade	t <sub>DOUT</sub>	t <sub>DP</sub>	t <sub>DIN</sub>	t <sub>PY</sub>	t <sub>EOUT</sub>	t <sub>ZL</sub>	t <sub>ZH</sub>	t <sub>LZ</sub>	t <sub>HZ</sub>	t <sub>ZLS</sub>	t <sub>ZHS</sub>	Units
Std.	0.98	2.62	0.19	1.77	0.67	2.66	2.40			6.29	6.03	ns

Note: For specific junction temperature and voltage supply levels, refer to Table 2-6 on page 2-6 for derating values.

#### 1.2 V DC Core Voltage

**Table 2-96 • HSTL Class II – Applies to 1.2 V DC Core Voltage**  
Commercial-Case Conditions: T<sub>J</sub> = 70°C, Worst-Case VCC = 1.14 V,  
Worst-Case VCCI = 1.4 V VREF = 0.75 V

Speed Grade	t <sub>DOUT</sub>	t <sub>DP</sub>	t <sub>DIN</sub>	t <sub>PY</sub>	t <sub>EOUT</sub>	t <sub>ZL</sub>	t <sub>ZH</sub>	t <sub>LZ</sub>	t <sub>HZ</sub>	t <sub>ZLS</sub>	t <sub>ZHS</sub>	Units
Std.	1.55	2.93	0.26	1.94	1.10	2.98	2.75			8.79	8.55	ns

Note: For specific junction temperature and voltage supply levels, refer to Table 2-7 on page 2-6 for derating values.

## SSTL2 Class I

Stub-Speed Terminated Logic for 2.5 V memory bus standard (JESD8-9). IGLOOe devices support Class I. This provides a differential amplifier input buffer and a push-pull output buffer.

**Table 2-97 • Minimum and Maximum DC Input and Output Levels**

SSTL2 Class I	VIL		VIH		VOL	VOH	IOL	IOH	IOSH	IOSL	IIL <sup>1</sup>	IIH <sup>2</sup>
	Min. V	Max. V	Min. V	Max. V	Max. V	Min. V	mA	mA	Max. mA <sup>3</sup>	Max. mA <sup>3</sup>	μA <sup>4</sup>	μA <sup>4</sup>
15 mA	-0.3	VREF - 0.2	VREF + 0.2	3.6	0.54	VCCI - 0.62	15	15	83	87	10	10

**Notes:**

1. IIL is the input leakage current per I/O pin over recommended operating conditions where  $-0.3\text{ V} < V_{IN} < V_{IL}$ .
2. IIH is the input leakage current per I/O pin over recommended operating conditions  $V_{IH} < V_{IN} < V_{CCI}$ . Input current is larger when operating outside recommended ranges.
3. Currents are measured at high temperature (100°C junction temperature) and maximum voltage.
4. Currents are measured at 85°C junction temperature.

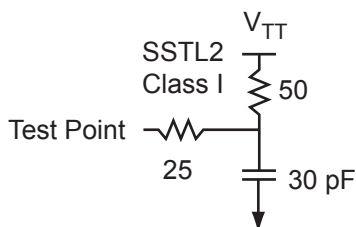

**Figure 2-19 • AC Loading**

**Table 2-98 • AC Waveforms, Measuring Points, and Capacitive Loads**

Input Low (V)	Input High (V)	Measuring Point* (V)	VREF (typ.) (V)	VTT (typ.) (V)	C <sub>LOAD</sub> (pF)
VREF - 0.2	VREF + 0.2	1.25	1.25	1.25	30

*Note:* \*Measuring point = V<sub>trip</sub>. See Table 2-23 on page 2-23 for a complete table of trip points.

### Timing Characteristics

#### 1.5 V DC Core Voltage

**Table 2-99 • SSTL 2 Class I – Applies to 1.5 V DC Core Voltage**  
Commercial-Case Conditions: T<sub>J</sub> = 70°C, Worst-Case VCC = 1.425 V,  
Worst-Case VCCI = 2.3 V VREF = 1.25 V

Speed Grade	t <sub>DOUT</sub>	t <sub>DP</sub>	t <sub>DIN</sub>	t <sub>PY</sub>	t <sub>EOOUT</sub>	t <sub>ZL</sub>	t <sub>ZH</sub>	t <sub>LZ</sub>	t <sub>HZ</sub>	t <sub>ZLS</sub>	t <sub>ZHS</sub>	Units
Std.	0.98	1.91	0.19	1.15	0.67	1.94	1.72			5.57	5.35	ns

*Note:* For specific junction temperature and voltage supply levels, refer to Table 2-6 on page 2-6 for derating values.

#### 1.2 V DC Core Voltage

**Table 2-100 • SSTL 2 Class I – Applies to 1.2 V DC Core Voltage**  
Commercial-Case Conditions: T<sub>J</sub> = 70°C, Worst-Case VCC = 1.14 V,  
Worst-Case VCCI = 2.3 V VREF = 1.25 V

Speed Grade	t <sub>DOUT</sub>	t <sub>DP</sub>	t <sub>DIN</sub>	t <sub>PY</sub>	t <sub>EOOUT</sub>	t <sub>ZL</sub>	t <sub>ZH</sub>	t <sub>LZ</sub>	t <sub>HZ</sub>	t <sub>ZLS</sub>	t <sub>ZHS</sub>	Units
Std.	1.55	2.17	0.26	1.39	1.10	2.21	2.04			8.02	7.84	ns

*Note:* For specific junction temperature and voltage supply levels, refer to Table 2-7 on page 2-6 for derating values.

## SSTL2 Class II

Stub-Speed Terminated Logic for 2.5 V memory bus standard (JESD8-9). IGLOOe devices support Class II. This provides a differential amplifier input buffer and a push-pull output buffer.

**Table 2-101 • Minimum and Maximum DC Input and Output Levels**

SSTL2 Class II	VIL		VIH		VOL	VOH	IOL	IOH	IOSH	IOSL	IIL <sup>1</sup>	IIH <sup>2</sup>
	Min. V	Max. V	Min. V	Max. V	Max. V	Min. V	mA	mA	Max. mA <sup>3</sup>	Max. mA <sup>3</sup>	μA <sup>4</sup>	μA <sup>4</sup>
18 mA	-0.3	VREF - 0.2	VREF + 0.2	3.6	0.35	VCCI - 0.43	18	18	169	124	10	10

**Notes:**

1. IIL is the input leakage current per I/O pin over recommended operating conditions where  $-0.3\text{ V} < V_{IN} < V_{IL}$ .
2. IIH is the input leakage current per I/O pin over recommended operating conditions  $V_{IH} < V_{IN} < V_{CCI}$ . Input current is larger when operating outside recommended ranges.
3. Currents are measured at high temperature (100°C junction temperature) and maximum voltage.
4. Currents are measured at 85°C junction temperature.

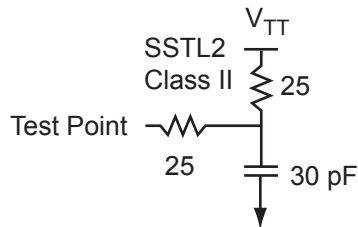

**Figure 2-20 • AC Loading**

**Table 2-102 • AC Waveforms, Measuring Points, and Capacitive Loads**

Input Low (V)	Input HIGH (V)	Measuring Point* (V)	VREF (typ.) (V)	VTT (typ.) (V)	C <sub>LOAD</sub> (pF)
VREF - 0.2	VREF + 0.2	1.25	1.25	1.25	30

Note: \*Measuring point = Vtrip. See Table 2-23 on page 2-23 for a complete table of trip points.

### Timing Characteristics

#### 1.5 V DC Core Voltage

**Table 2-103 • SSTL 2 Class II – Applies to 1.5 V DC Core Voltage**

Commercial-Case Conditions:  $T_J = 70^\circ\text{C}$ , Worst-Case VCC = 1.425 V,  
Worst-Case VCCI = 2.3 V VREF = 1.25 V

Speed Grade	t <sub>DOUT</sub>	t <sub>DP</sub>	t <sub>DIN</sub>	t <sub>PY</sub>	t <sub>EOUT</sub>	t <sub>ZL</sub>	t <sub>ZH</sub>	t <sub>LZ</sub>	t <sub>HZ</sub>	t <sub>ZLS</sub>	t <sub>ZHS</sub>	Units
Std.	0.98	1.94	0.19	1.15	0.67	1.97	1.66			5.60	5.29	ns

Note: For specific junction temperature and voltage supply levels, refer to Table 2-6 on page 2-6 for derating values.

#### 1.2 V DC Core Voltage

**Table 2-104 • SSTL 2 Class II – Applies to 1.2 V DC Core Voltage**

Commercial-Case Conditions:  $T_J = 70^\circ\text{C}$ , Worst-Case VCC = 1.14 V,  
Worst-Case VCCI = 2.3 V VREF = 1.25 V

Speed Grade	t <sub>DOUT</sub>	t <sub>DP</sub>	t <sub>DIN</sub>	t <sub>PY</sub>	t <sub>EOUT</sub>	t <sub>ZL</sub>	t <sub>ZH</sub>	t <sub>LZ</sub>	t <sub>HZ</sub>	t <sub>ZLS</sub>	t <sub>ZHS</sub>	Units
Std.	1.55	2.20	0.26	1.39	1.10	2.24	1.97			8.05	7.78	ns

Note: For specific junction temperature and voltage supply levels, refer to Table 2-7 on page 2-6 for derating values.

## SSTL3 Class I

Stub-Speed Terminated Logic for 3.3 V memory bus standard (JESD8-8). IGLOOe devices support Class I. This provides a differential amplifier input buffer and a push-pull output buffer.

**Table 2-105 • Minimum and Maximum DC Input and Output Levels**

SSTL3 Class I	VIL		VIH		VOL	VOH	IOL	IOH	IOSH	IOSL	IIL <sup>1</sup>	IIH <sup>2</sup>
	Min. V	Max. V	Min. V	Max. V	Max. V	Min. V	mA	mA	mA <sup>3</sup>	mA <sup>3</sup>	μA <sup>4</sup>	μA <sup>4</sup>
14 mA	-0.3	VREF - 0.2	VREF + 0.2	3.6	0.7	VCCI - 1.1	14	14	51	54	10	10

**Notes:**

1. IIL is the input leakage current per I/O pin over recommended operating conditions where  $-0.3\text{ V} < V_{IN} < V_{IL}$ .
2. IIH is the input leakage current per I/O pin over recommended operating conditions  $V_{IH} < V_{IN} < V_{CCI}$ . Input current is larger when operating outside recommended ranges.
3. Currents are measured at high temperature (100°C junction temperature) and maximum voltage.
4. Currents are measured at 85°C junction temperature.

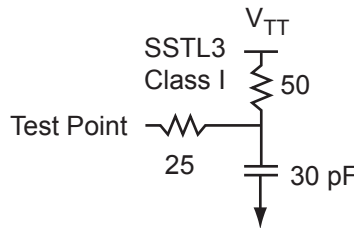

**Figure 2-21 • AC Loading**

**Table 2-106 • AC Waveforms, Measuring Points, and Capacitive Loads**

Input Low (V)	Input High (V)	Measuring Point* (V)	VREF (typ.) (V)	VTT (typ.) (V)	C <sub>LOAD</sub> (pF)
VREF - 0.2	VREF + 0.2	1.5	1.5	1.485	30

Note: \*Measuring point = V<sub>trip</sub>. See Table 2-23 on page 2-23 for a complete table of trip points.

### Timing Characteristics

#### 1.5 V DC Core Voltage

**Table 2-107 • SSTL 3 Class I – Applies to 1.5 V DC Core Voltage**  
Commercial-Case Conditions: T<sub>J</sub> = 70°C, Worst-Case VCC = 1.425 V,  
Worst-Case VCCI = 3.0 V VREF = 1.5 V

Speed Grade	t <sub>DOUT</sub>	t <sub>DP</sub>	t <sub>DIN</sub>	t <sub>PY</sub>	t <sub>EOUT</sub>	t <sub>ZL</sub>	t <sub>ZH</sub>	t <sub>LZ</sub>	t <sub>HZ</sub>	t <sub>ZLS</sub>	t <sub>ZHS</sub>	Units
Std.	0.98	2.05	0.19	1.09	0.67	2.09	1.71			5.72	5.34	ns

Note: For specific junction temperature and voltage supply levels, refer to Table 2-6 on page 2-6 for derating values.

#### 1.2 V DC Core Voltage

**Table 2-108 • SSTL 3 Class I – Applies to 1.2 V DC Core Voltage**  
Commercial-Case Conditions: T<sub>J</sub> = 70°C, Worst-Case VCC = 1.14 V,  
Worst-Case VCCI = 3.0 V VREF = 1.5 V

Speed Grade	t <sub>DOUT</sub>	t <sub>DP</sub>	t <sub>DIN</sub>	t <sub>PY</sub>	t <sub>EOUT</sub>	t <sub>ZL</sub>	t <sub>ZH</sub>	t <sub>LZ</sub>	t <sub>HZ</sub>	t <sub>ZLS</sub>	t <sub>ZHS</sub>	Units
Std.	1.55	2.32	0.26	1.32	1.10	2.37	2.02			8.17	7.83	ns

Note: For specific junction temperature and voltage supply levels, refer to Table 2-7 on page 2-6 for derating values.

## SSTL3 Class II

Stub-Speed Terminated Logic for 3.3 V memory bus standard (JESD8-8). IGLOOe devices support Class II. This provides a differential amplifier input buffer and a push-pull output buffer.

**Table 2-109 • Minimum and Maximum DC Input and Output Levels**

SSTL3 Class II	VIL		VIH		VOL	VOH	IOL	IOH	IOSH	IOSL	IIL <sup>1</sup>	IIH <sup>2</sup>
	Min. V	Max. V	Min. V	Max. V	Max. V	Min. V	mA	mA	mA <sup>3</sup>	mA <sup>3</sup>	μA <sup>4</sup>	μA <sup>4</sup>
21 mA	-0.3	VREF - 0.2	VREF + 0.2	3.6	0.5	VCCI - 0.9	21	21	103	109	10	10

**Notes:**

1. IIL is the input leakage current per I/O pin over recommended operating conditions where  $-0.3\text{ V} < V_{IN} < V_{IL}$ .
2. IIH is the input leakage current per I/O pin over recommended operating conditions  $V_{IH} < V_{IN} < V_{CCI}$ . Input current is larger when operating outside recommended ranges.
3. Currents are measured at high temperature (100°C junction temperature) and maximum voltage.
4. Currents are measured at 85°C junction temperature.

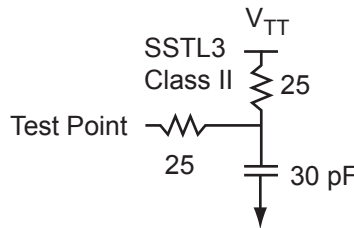

**Figure 2-22 • AC Loading**

**Table 2-110 • AC Waveforms, Measuring Points, and Capacitive Loads**

Input Low (V)	Input High (V)	Measuring Point* (V)	VREF (typ.) (V)	VTT (typ.) (V)	C <sub>LOAD</sub> (pF)
VREF - 0.2	VREF + 0.2	1.5	1.5	1.485	30

Note: Measuring point = Vtrip. See Table 2-23 on page 2-23 for a complete table of trip points.

### Timing Characteristics

#### 1.5 V DC Core Voltage

**Table 2-111 • SSTL 3 Class II – Applies to 1.5 V DC Core Voltage**

Commercial-Case Conditions:  $T_J = 70^\circ\text{C}$ , Worst-Case VCC = 1.425 V, Worst-Case VCCI = 3.0 V VREF = 1.5 V

Speed Grade	t <sub>DOUT</sub>	t <sub>DP</sub>	t <sub>DIN</sub>	t <sub>PY</sub>	t <sub>EOUT</sub>	t <sub>ZL</sub>	t <sub>ZH</sub>	t <sub>LZ</sub>	t <sub>HZ</sub>	t <sub>ZLS</sub>	t <sub>ZHS</sub>	Units
Std.	0.98	1.86	0.19	1.09	0.67	1.89	1.58			5.52	5.21	ns

Note: For specific junction temperature and voltage supply levels, refer to Table 2-6 on page 2-6 for derating values.

#### 1.2 V DC Core Voltage

**Table 2-112 • SSTL 3 Class II – Applies to 1.2 V DC Core Voltage**

Commercial-Case Conditions:  $T_J = 70^\circ\text{C}$ , Worst-Case VCC = 1.14 V, Worst-Case VCCI = 3.0 V VREF = 1.5 V

Speed Grade	t <sub>DOUT</sub>	t <sub>DP</sub>	t <sub>DIN</sub>	t <sub>PY</sub>	t <sub>EOUT</sub>	t <sub>ZL</sub>	t <sub>ZH</sub>	t <sub>LZ</sub>	t <sub>HZ</sub>	t <sub>ZLS</sub>	t <sub>ZHS</sub>	Units
Std.	1.55	2.12	0.26	1.32	1.10	2.16	1.89			7.97	7.70	ns

Note: For specific junction temperature and voltage supply levels, refer to Table 2-7 on page 2-6 for derating values.

## Differential I/O Characteristics

### Physical Implementation

Configuration of the I/O modules as a differential pair is handled by the Microsemi Designer software when the user instantiates a differential I/O macro in the design.

Differential I/Os can also be used in conjunction with the embedded Input Register (InReg), Output Register (OutReg), Enable Register (EnReg), and DDR. However, there is no support for bidirectional I/Os or tristates with the LVPECL standards.

### LVDS

Low-Voltage Differential Signaling (ANSI/TIA/EIA-644) is a high-speed, differential I/O standard. It requires that one data bit be carried through two signal lines, so two pins are needed. It also requires external resistor termination.

The full implementation of the LVDS transmitter and receiver is shown in an example in [Figure 2-23](#). The building blocks of the LVDS transmitter-receiver are one transmitter macro, one receiver macro, three board resistors at the transmitter end, and one resistor at the receiver end. The values for the three driver resistors are different from those used in the LVPECL implementation because the output standard specifications are different.

Along with LVDS I/O, IGLOOe also supports Bus LVDS structure and Multipoint LVDS (M-LVDS) configuration (up to 40 nodes).

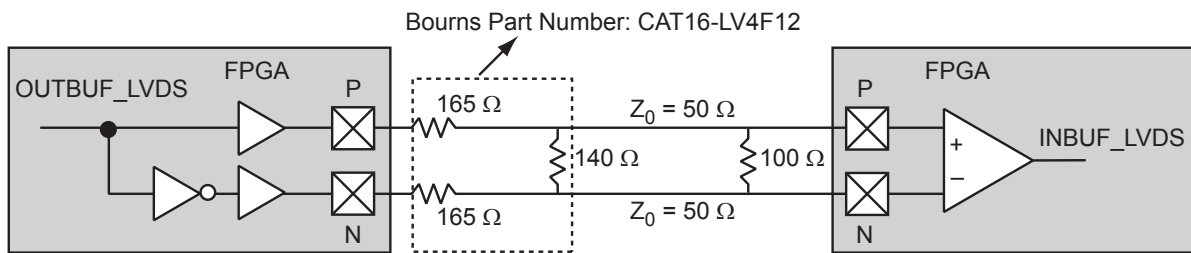

**Figure 2-23 • LVDS Circuit Diagram and Board-Level Implementation**

**Table 2-113 • Minimum and Maximum DC Input and Output Levels**

DC Parameter	Description	Min.	Typ.	Max.	Units
VCCI	Supply Voltage	2.375	2.5	2.625	V
VOL	Output Low Voltage	0.9	1.075	1.25	V
VOH	Output High Voltage	1.25	1.425	1.6	V
IOL <sup>1</sup>	Output Lower Current	0.65	0.91	1.16	mA
IOH <sup>1</sup>	Output High Current	0.65	0.91	1.16	mA
VI	Input Voltage	0		2.925	V
IIH <sup>2,3</sup>	Input High Leakage Current			10	μA
IIL <sup>2,4</sup>	Input Low Leakage Current			10	μA
VODIFF	Differential Output Voltage	250	350	450	mV
VOCM	Output Common Mode Voltage	1.125	1.25	1.375	V
VICM	Input Common Mode Voltage	0.05	1.25	2.35	V
VIDIFF	Input Differential Voltage	100	350		mV

**Notes:**

1. IOL/IOH is defined by VODIFF/(resistor network).
2. Currents are measured at 85°C junction temperature.
3. IIH is the input leakage current per I/O pin over recommended operating conditions  $V_{IH} < V_{IN} < V_{CCI}$ . Input current is larger when operating outside recommended ranges.
4. IIL is the input leakage current per I/O pin over recommended operating conditions where  $-0.3 \text{ V} < V_{IN} < V_{IL}$ .

**Table 2-114 • AC Waveforms, Measuring Points, and Capacitive Loads**

Input Low (V)	Input High (V)	Measuring Point* (V)	VREF (typ.) (V)
1.075	1.325	Cross point	–

Note: \*Measuring point =  $V_{trip}$ . See Table 2-23 on page 2-23 for a complete table of trip points.

### Timing Characteristics

#### 1.5 V DC Core Voltage

**Table 2-115 • LVDS – Applies to 1.5 V DC Core Voltage**

Commercial-Case Conditions:  $T_j = 70^\circ\text{C}$ , Worst-Case VCC = 1.425 V, Worst-Case VCCI = 2.3 V

Speed Grade	$t_{DOUT}$	$t_{DP}$	$t_{DIN}$	$t_{pY}$	Units
Std.	0.98	1.77	0.19	1.62	ns

Note: For specific junction temperature and voltage supply levels, refer to Table 2-6 on page 2-6 for derating values.

#### 1.2 V DC Core Voltage

**Table 2-116 • LVDS – Applies to 1.2 V DC Core Voltage**

Commercial-Case Conditions:  $T_j = 70^\circ\text{C}$ , Worst-Case VCC = 1.14 V, Worst-Case VCCI = 2.3 V

Speed Grade	$t_{DOUT}$	$t_{DP}$	$t_{DIN}$	$t_{pY}$	Units
Std.	1.55	2.19	0.26	1.88	ns

Note: For specific junction temperature and voltage supply levels, refer to Table 2-7 on page 2-6 for derating values.

### B-LVDS/M-LVDS

Bus LVDS (B-LVDS) and Multipoint LVDS (M-LVDS) specifications extend the existing LVDS standard to high-performance multipoint bus applications. Multidrop and multipoint bus configurations may contain any combination of drivers, receivers, and transceivers. Microsemi LVDS drivers provide the higher drive current required by B-LVDS and M-LVDS to accommodate the loading. The drivers require series terminations for better signal quality and to control voltage swing. Termination is also required at both ends of the bus since the driver can be located anywhere on the bus. These configurations can be implemented using the TRIBUF\_LVDS and BIBUF\_LVDS macros along with appropriate terminations. Multipoint designs using Microsemi LVDS macros can achieve up to 200 MHz with a maximum of 20 loads. A sample application is given in [Figure 2-24](#). The input and output buffer delays are available in the LVDS section in [Table 2-115 on page 2-63](#) and [Table 2-116 on page 2-63](#).

Example: For a bus consisting of 20 equidistant loads, the following terminations provide the required differential voltage, in worst-case Industrial operating conditions, at the farthest receiver:  $R_S = 60 \Omega$  and  $R_T = 70 \Omega$ , given  $Z_0 = 50 \Omega$  (2") and  $Z_{stub} = 50 \Omega$  (~1.5").

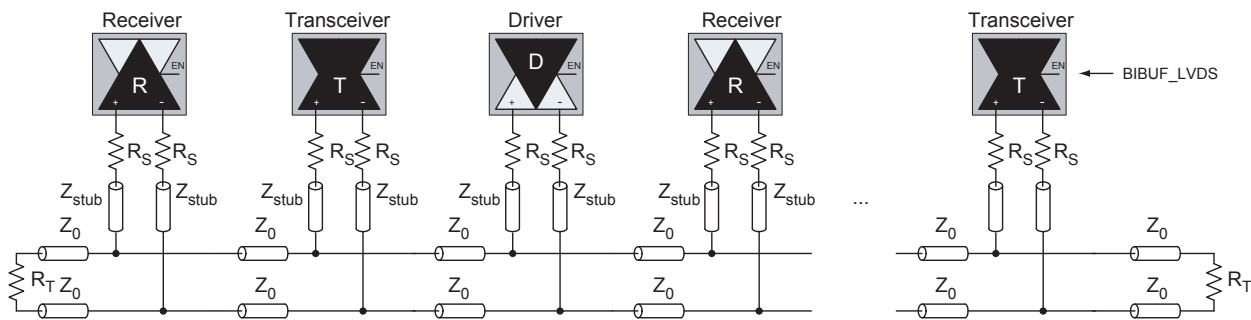
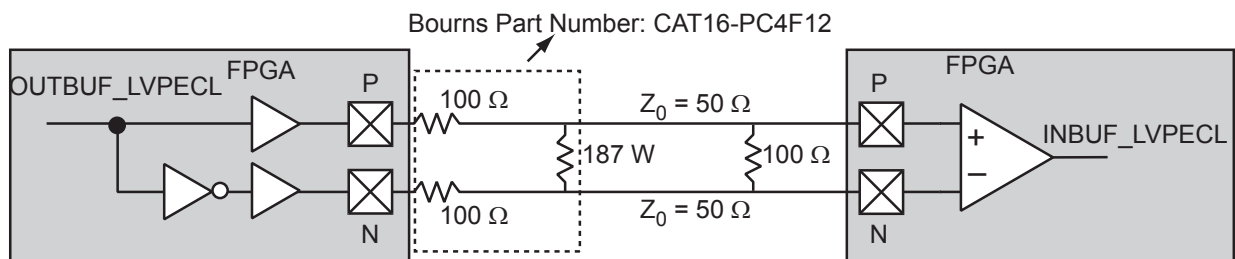

**Figure 2-24 • B-LVDS/M-LVDS Multipoint Application Using LVDS I/O Buffers**

### LVPECL

Low-Voltage Positive Emitter-Coupled Logic (LVPECL) is another differential I/O standard. It requires that one data bit be carried through two signal lines. Like LVDS, two pins are needed. It also requires external resistor termination.

The full implementation of the LVDS transmitter and receiver is shown in an example in [Figure 2-25](#). The building blocks of the LVPECL transmitter-receiver are one transmitter macro, one receiver macro, three board resistors at the transmitter end, and one resistor at the receiver end. The values for the three driver resistors are different from those used in the LVDS implementation because the output standard specifications are different.



**Figure 2-25 • LVPECL Circuit Diagram and Board-Level Implementation**

**Table 2-117 • Minimum and Maximum DC Input and Output Levels**

DC Parameter	Description	Min.	Max.	Min.	Max.	Min.	Max.	Units
VCCI	Supply Voltage	3.0		3.3		3.6		V
VOL	Output Low Voltage	0.96	1.27	1.06	1.43	1.30	1.57	V
VOH	Output High Voltage	1.8	2.11	1.92	2.28	2.13	2.41	V
VIL, VIH	Input Low, Input High Voltages	0	3.6	0	3.6	0	3.6	V
VODIFF	Differential Output Voltage	0.625	0.97	0.625	0.97	0.625	0.97	V
VOCM	Output Common Mode Voltage	1.762	1.98	1.762	1.98	1.762	1.98	V
VICM	Input Common Mode Voltage	1.01	2.57	1.01	2.57	1.01	2.57	V
VIDIFF	Input Differential Voltage	300		300		300		mV

**Table 2-118 • AC Waveforms, Measuring Points, and Capacitive Loads**

Input LOW (V)	Input HIGH (V)	Measuring Point* (V)	VREF (typ.) (V)
1.64	1.94	Cross point	–

Note: \*Measuring point =  $V_{trip}$ . See Table 2-23 on page 2-23 for a complete table of trip points.

### Timing Characteristics

#### 1.5 V DC Core Voltage

**Table 2-119 • LVPECL – Applies to 1.5 V DC Core Voltage**

Commercial-Case Conditions:  $T_J = 70^\circ\text{C}$ , Worst-Case VCC = 1.425 V, Worst-Case VCCI = 3.0 V

Speed Grade	$t_{DOUT}$	$t_{DP}$	$t_{DIN}$	$t_{pY}$	Units
Std.	0.98	1.75	0.19	1.45	ns

Note: For specific junction temperature and voltage supply levels, refer to Table 2-6 on page 2-6 for derating values.

#### 1.2 V DC Core Voltage

**Table 2-120 • LVPECL – Applies to 1.2 V DC Core Voltage**

Commercial-Case Conditions:  $T_J = 70^\circ\text{C}$ , Worst-Case VCC = 1.14 V, Worst-Case VCCI = 3.0 V

Speed Grade	$t_{DOUT}$	$t_{DP}$	$t_{DIN}$	$t_{pY}$	Units
Std.	1.55	2.16	0.26	1.70	ns

Note: For specific junction temperature and voltage supply levels, refer to Table 2-7 on page 2-6 for derating values.

## I/O Register Specifications

### Fully Registered I/O Buffers with Synchronous Enable and Asynchronous Preset

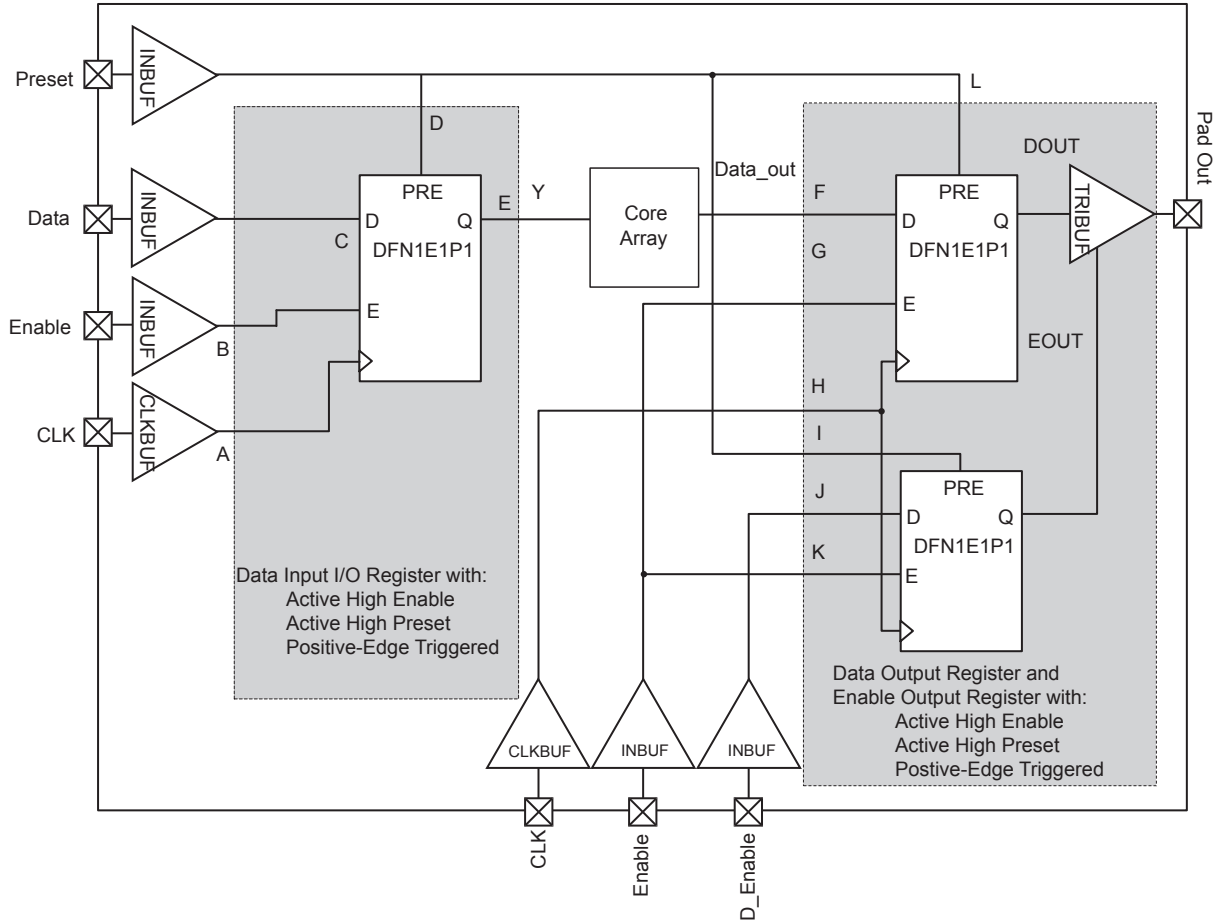

Figure 2-26 • Timing Model of Registered I/O Buffers with Synchronous Enable and Asynchronous Preset

**Table 2-121 • Parameter Definition and Measuring Nodes**

Parameter Name	Parameter Definition	Measuring Nodes (from, to)*
$t_{OCLKQ}$	Clock-to-Q of the Output Data Register	H, DOUT
$t_{OSUD}$	Data Setup Time for the Output Data Register	F, H
$t_{OHD}$	Data Hold Time for the Output Data Register	F, H
$t_{OSUE}$	Enable Setup Time for the Output Data Register	G, H
$t_{OHE}$	Enable Hold Time for the Output Data Register	G, H
$t_{OPRE2Q}$	Asynchronous Preset-to-Q of the Output Data Register	L, DOUT
$t_{OREMPRE}$	Asynchronous Preset Removal Time for the Output Data Register	L, H
$t_{ORECPRE}$	Asynchronous Preset Recovery Time for the Output Data Register	L, H
$t_{OECLKQ}$	Clock-to-Q of the Output Enable Register	H, EOUT
$t_{OESUD}$	Data Setup Time for the Output Enable Register	J, H
$t_{OEHD}$	Data Hold Time for the Output Enable Register	J, H
$t_{OESUE}$	Enable Setup Time for the Output Enable Register	K, H
$t_{OEHE}$	Enable Hold Time for the Output Enable Register	K, H
$t_{OEPRE2Q}$	Asynchronous Preset-to-Q of the Output Enable Register	I, EOUT
$t_{OEREMPRE}$	Asynchronous Preset Removal Time for the Output Enable Register	I, H
$t_{OERECPRE}$	Asynchronous Preset Recovery Time for the Output Enable Register	I, H
$t_{iCLKQ}$	Clock-to-Q of the Input Data Register	A, E
$t_{iSUD}$	Data Setup Time for the Input Data Register	C, A
$t_{iHD}$	Data Hold Time for the Input Data Register	C, A
$t_{iSUE}$	Enable Setup Time for the Input Data Register	B, A
$t_{iHE}$	Enable Hold Time for the Input Data Register	B, A
$t_{iPRE2Q}$	Asynchronous Preset-to-Q of the Input Data Register	D, E
$t_{iREMPRE}$	Asynchronous Preset Removal Time for the Input Data Register	D, A
$t_{iRECPRE}$	Asynchronous Preset Recovery Time for the Input Data Register	D, A

Note: See Figure 2-26 on page 2-66 for more information.

### Fully Registered I/O Buffers with Synchronous Enable and Asynchronous Clear

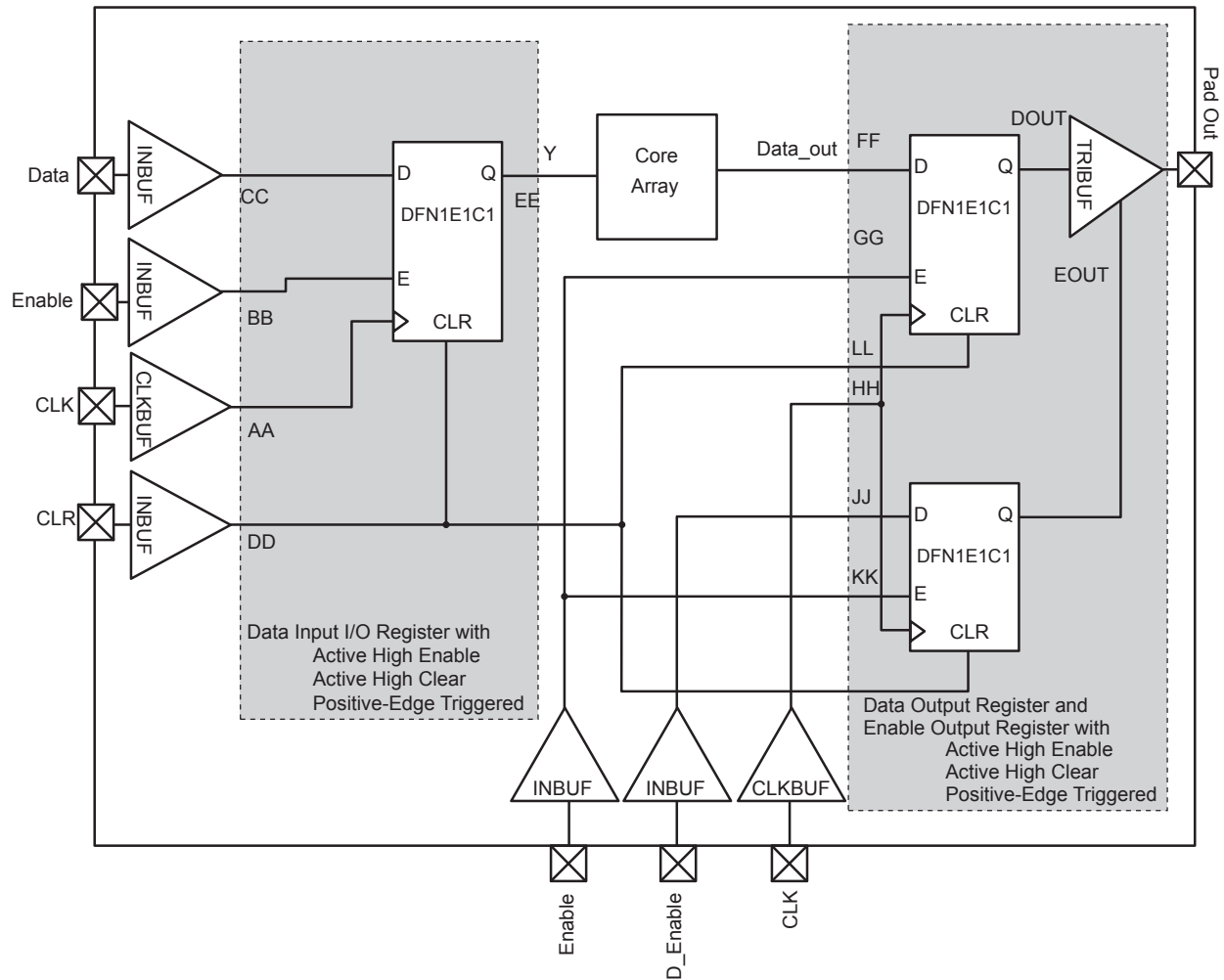

Figure 2-27 • Timing Model of the Registered I/O Buffers with Synchronous Enable and Asynchronous Clear

**Table 2-122 • Parameter Definition and Measuring Nodes**

Parameter Name	Parameter Definition	Measuring Nodes (from, to)*
t <sub>OCLKQ</sub>	Clock-to-Q of the Output Data Register	HH, DOUT
t <sub>OSUD</sub>	Data Setup Time for the Output Data Register	FF, HH
t <sub>OHD</sub>	Data Hold Time for the Output Data Register	FF, HH
t <sub>OSUE</sub>	Enable Setup Time for the Output Data Register	GG, HH
t <sub>OHE</sub>	Enable Hold Time for the Output Data Register	GG, HH
t <sub>OCLR2Q</sub>	Asynchronous Clear-to-Q of the Output Data Register	LL, DOUT
t <sub>OEMCLR</sub>	Asynchronous Clear Removal Time for the Output Data Register	LL, HH
t <sub>OECCLR</sub>	Asynchronous Clear Recovery Time for the Output Data Register	LL, HH
t <sub>OELKQ</sub>	Clock-to-Q of the Output Enable Register	HH, EOUT
t <sub>OSUD</sub>	Data Setup Time for the Output Enable Register	JJ, HH
t <sub>OEH</sub>	Data Hold Time for the Output Enable Register	JJ, HH
t <sub>OSUE</sub>	Enable Setup Time for the Output Enable Register	KK, HH
t <sub>OHE</sub>	Enable Hold Time for the Output Enable Register	KK, HH
t <sub>OCLR2Q</sub>	Asynchronous Clear-to-Q of the Output Enable Register	II, EOUT
t <sub>OEMCLR</sub>	Asynchronous Clear Removal Time for the Output Enable Register	II, HH
t <sub>OECCLR</sub>	Asynchronous Clear Recovery Time for the Output Enable Register	II, HH
t <sub>CLKQ</sub>	Clock-to-Q of the Input Data Register	AA, EE
t <sub>ISUD</sub>	Data Setup Time for the Input Data Register	CC, AA
t <sub>IHD</sub>	Data Hold Time for the Input Data Register	CC, AA
t <sub>ISUE</sub>	Enable Setup Time for the Input Data Register	BB, AA
t <sub>IHE</sub>	Enable Hold Time for the Input Data Register	BB, AA
t <sub>CLR2Q</sub>	Asynchronous Clear-to-Q of the Input Data Register	DD, EE
t <sub>IREMCLR</sub>	Asynchronous Clear Removal Time for the Input Data Register	DD, AA
t <sub>IRECCLR</sub>	Asynchronous Clear Recovery Time for the Input Data Register	DD, AA

Note: \*See Figure 2-27 on page 2-68 for more information.

## Input Register

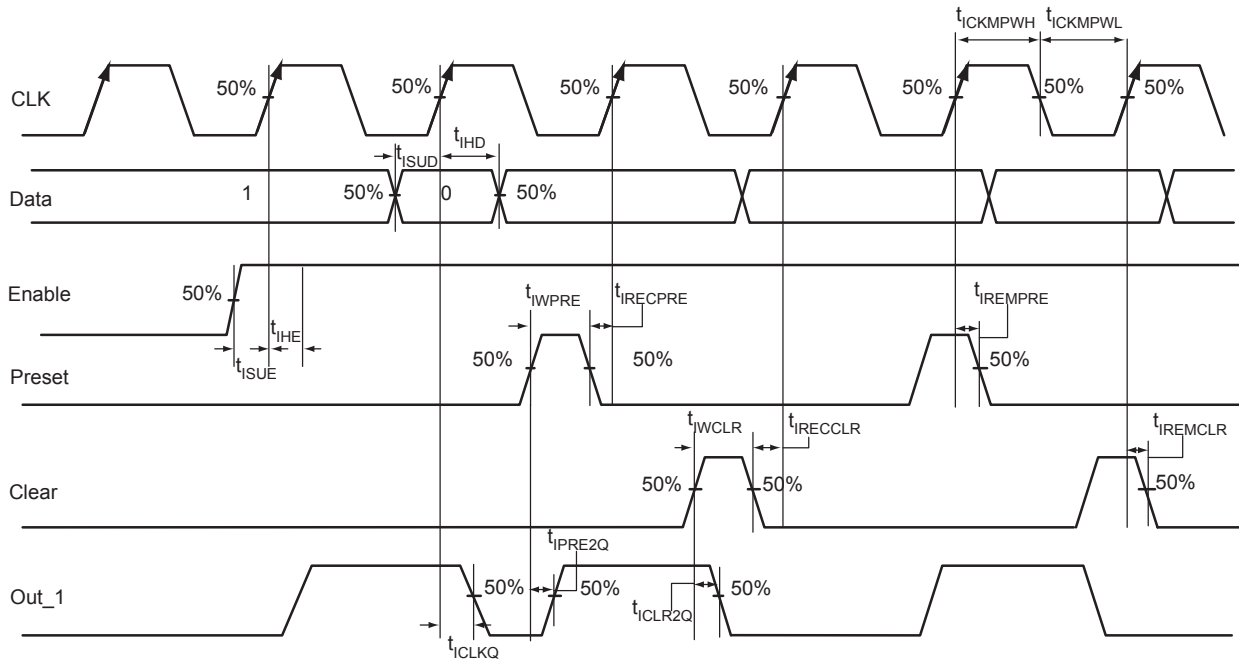

Figure 2-28 • Input Register Timing Diagram

### Timing Characteristics

#### 1.5 V DC Core Voltage

Table 2-123 • Input Data Register Propagation Delays  
Commercial-Case Conditions:  $T_J = 70^\circ\text{C}$ , Worst-Case  $V_{CC} = 1.425\text{ V}$

Parameter	Description	Std.	Units
$t_{CLKQ}$	Clock-to-Q of the Input Data Register	0.42	ns
$t_{ISUD}$	Data Setup Time for the Input Data Register	0.47	ns
$t_{IHD}$	Data Hold Time for the Input Data Register	0.00	ns
$t_{ISUE}$	Enable Setup Time for the Input Data Register	0.67	ns
$t_{IHE}$	Enable Hold Time for the Input Data Register	0.00	ns
$t_{ICLR2Q}$	Asynchronous Clear-to-Q of the Input Data Register	0.79	ns
$t_{IPRE2Q}$	Asynchronous Preset-to-Q of the Input Data Register	0.79	ns
$t_{IREMCLR}$	Asynchronous Clear Removal Time for the Input Data Register	0.00	ns
$t_{IRECCLR}$	Asynchronous Clear Recovery Time for the Input Data Register	0.24	ns
$t_{IREMPRE}$	Asynchronous Preset Removal Time for the Input Data Register	0.00	ns
$t_{IRECPRE}$	Asynchronous Preset Recovery Time for the Input Data Register	0.24	ns
$t_{IWCLR}$	Asynchronous Clear Minimum Pulse Width for the Input Data Register	0.19	ns
$t_{IWPRE}$	Asynchronous Preset Minimum Pulse Width for the Input Data Register	0.19	ns
$t_{ICKMPWH}$	Clock Minimum Pulse Width HIGH for the Input Data Register	0.31	ns
$t_{ICKMPWL}$	Clock Minimum Pulse Width LOW for the Input Data Register	0.28	ns

Note: For specific junction temperature and voltage supply levels, refer to Table 2-6 on page 2-6 for derating values.

### 1.2 V DC Core Voltage

**Table 2-124 • Input Data Register Propagation Delays**  
**Commercial-Case Conditions:  $T_J = 70^\circ\text{C}$ , Worst-Case  $V_{CC} = 1.14\text{ V}$**

Parameter	Description	Std.	Units
$t_{\text{CLKQ}}$	Clock-to-Q of the Input Data Register	0.68	ns
$t_{\text{SUD}}$	Data Setup Time for the Input Data Register	0.97	ns
$t_{\text{IHD}}$	Data Hold Time for the Input Data Register	0.00	ns
$t_{\text{SUE}}$	Enable Setup Time for the Input Data Register	1.02	ns
$t_{\text{IHE}}$	Enable Hold Time for the Input Data Register	0.00	ns
$t_{\text{CLR2Q}}$	Asynchronous Clear-to-Q of the Input Data Register	1.19	ns
$t_{\text{PRE2Q}}$	Asynchronous Preset-to-Q of the Input Data Register	1.19	ns
$t_{\text{REMCLR}}$	Asynchronous Clear Removal Time for the Input Data Register	0.00	ns
$t_{\text{RECCLR}}$	Asynchronous Clear Recovery Time for the Input Data Register	0.24	ns
$t_{\text{REMPRE}}$	Asynchronous Preset Removal Time for the Input Data Register	0.00	ns
$t_{\text{RECPRE}}$	Asynchronous Preset Recovery Time for the Input Data Register	0.24	ns
$t_{\text{WCLR}}$	Asynchronous Clear Minimum Pulse Width for the Input Data Register	0.19	ns
$t_{\text{WPRE}}$	Asynchronous Preset Minimum Pulse Width for the Input Data Register	0.19	ns
$t_{\text{CKMPWH}}$	Clock Minimum Pulse Width HIGH for the Input Data Register	0.31	ns
$t_{\text{CKMPWL}}$	Clock Minimum Pulse Width LOW for the Input Data Register	0.28	ns

*Note:* For specific junction temperature and voltage supply levels, refer to [Table 2-7 on page 2-6](#) for derating values.

## Output Register

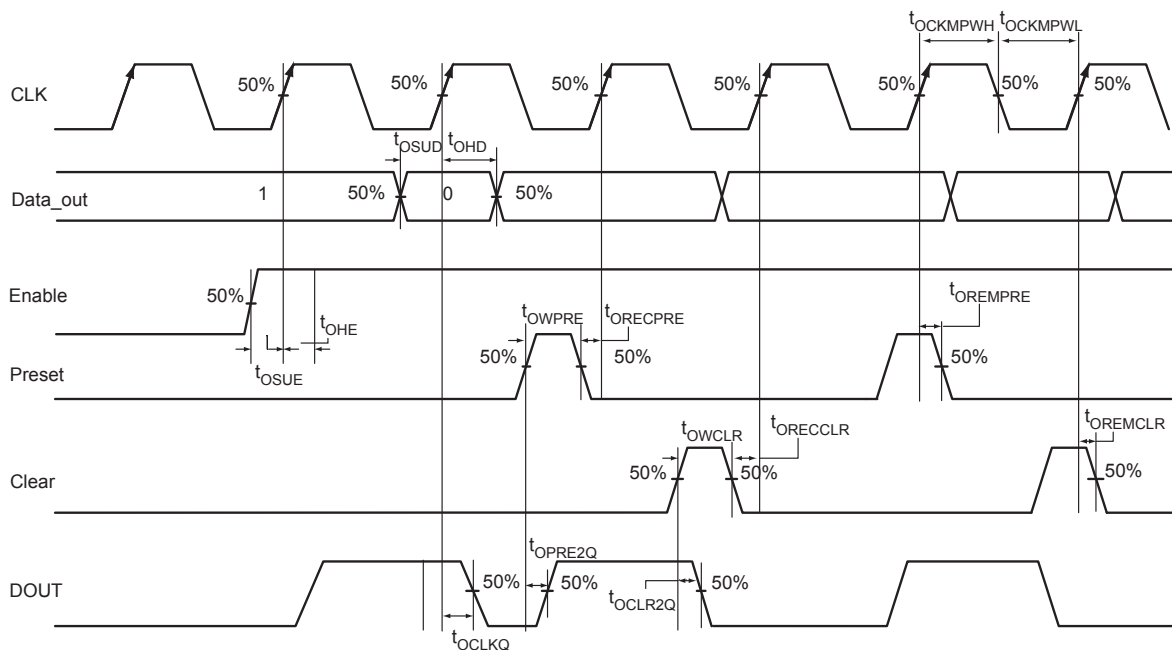

**Figure 2-29 • Output Register Timing Diagram**

### Timing Characteristics

1.5 V DC Core Voltage

**Table 2-125 • Output Data Register Propagation Delays**  
Commercial-Case Conditions:  $T_J = 70^\circ\text{C}$ , Worst-Case  $V_{CC} = 1.425\text{ V}$

Parameter	Description	Std.	Units
$t_{OCLKQ}$	Clock-to-Q of the Output Data Register	1.00	ns
$t_{OSUD}$	Data Setup Time for the Output Data Register	0.51	ns
$t_{OHD}$	Data Hold Time for the Output Data Register	0.00	ns
$t_{OSUE}$	Enable Setup Time for the Output Data Register	0.70	ns
$t_{OHE}$	Enable Hold Time for the Output Data Register	0.00	ns
$t_{OCLR2Q}$	Asynchronous Clear-to-Q of the Output Data Register	1.34	ns
$t_{OPRE2Q}$	Asynchronous Preset-to-Q of the Output Data Register	1.34	ns
$t_{OREMCLR}$	Asynchronous Clear Removal Time for the Output Data Register	0.00	ns
$t_{ORECCLR}$	Asynchronous Clear Recovery Time for the Output Data Register	0.24	ns
$t_{OREMPRE}$	Asynchronous Preset Removal Time for the Output Data Register	0.00	ns
$t_{ORECPRE}$	Asynchronous Preset Recovery Time for the Output Data Register	0.24	ns
$t_{OWCLR}$	Asynchronous Clear Minimum Pulse Width for the Output Data Register	0.19	ns
$t_{OWPRE}$	Asynchronous Preset Minimum Pulse Width for the Output Data Register	0.19	ns
$t_{OCKMPWH}$	Clock Minimum Pulse Width HIGH for the Output Data Register	0.31	ns
$t_{OCKMPWL}$	Clock Minimum Pulse Width LOW for the Output Data Register	0.28	ns

*Note:* For specific junction temperature and voltage supply levels, refer to Table 2-6 on page 2-6 for derating values.

### 1.2 V DC Core Voltage

**Table 2-126 • Output Data Register Propagation Delays**  
**Commercial-Case Conditions:  $T_J = 70^\circ\text{C}$ , Worst-Case  $V_{CC} = 1.14\text{ V}$**

Parameter	Description	Std.	Units
$t_{\text{OCLKQ}}$	Clock-to-Q of the Output Data Register	1.52	ns
$t_{\text{OSUD}}$	Data Setup Time for the Output Data Register	1.15	ns
$t_{\text{OHD}}$	Data Hold Time for the Output Data Register	0.00	ns
$t_{\text{OSUE}}$	Enable Setup Time for the Output Data Register	1.11	ns
$t_{\text{OHE}}$	Enable Hold Time for the Output Data Register	0.00	ns
$t_{\text{OCLR2Q}}$	Asynchronous Clear-to-Q of the Output Data Register	1.96	ns
$t_{\text{OPRE2Q}}$	Asynchronous Preset-to-Q of the Output Data Register	1.96	ns
$t_{\text{OREMCLR}}$	Asynchronous Clear Removal Time for the Output Data Register	0.00	ns
$t_{\text{ORECCLR}}$	Asynchronous Clear Recovery Time for the Output Data Register	0.24	ns
$t_{\text{OREMPRE}}$	Asynchronous Preset Removal Time for the Output Data Register	0.00	ns
$t_{\text{ORECPRE}}$	Asynchronous Preset Recovery Time for the Output Data Register	0.24	ns
$t_{\text{OWCLR}}$	Asynchronous Clear Minimum Pulse Width for the Output Data Register	0.19	ns
$t_{\text{OWPRE}}$	Asynchronous Preset Minimum Pulse Width for the Output Data Register	0.19	ns
$t_{\text{OCKMPWH}}$	Clock Minimum Pulse Width HIGH for the Output Data Register	0.31	ns
$t_{\text{OCKMPWL}}$	Clock Minimum Pulse Width LOW for the Output Data Register	0.28	ns

*Note:* For specific junction temperature and voltage supply levels, refer to [Table 2-7 on page 2-6](#) for derating values.

## Output Enable Register

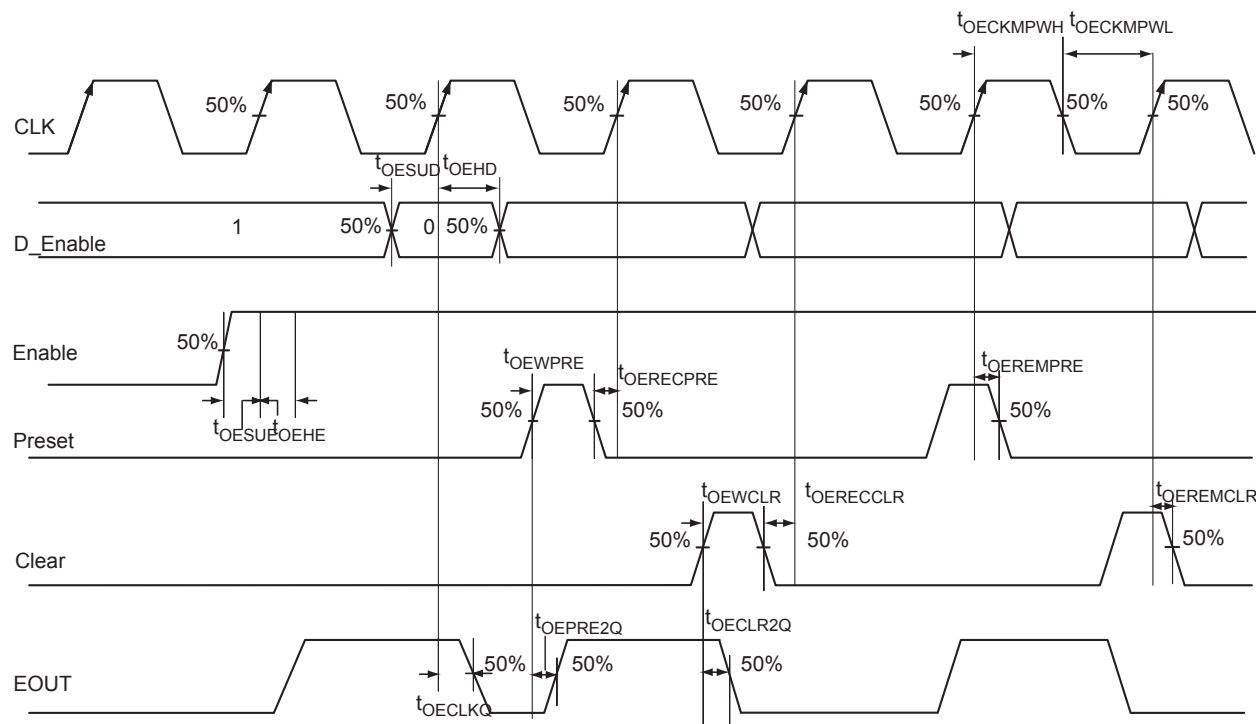

**Figure 2-30 • Output Enable Register Timing Diagram**

### Timing Characteristics

#### 1.5 V DC Core Voltage

**Table 2-127 • Output Enable Register Propagation Delays**  
Commercial-Case Conditions:  $T_j = 70^\circ\text{C}$ , Worst-Case  $V_{CC} = 1.425\text{ V}$

Parameter	Description	Std.	Units
$t_{OECLKQ}$	Clock-to-Q of the Output Enable Register	0.75	ns
$t_{OESUD}$	Data Setup Time for the Output Enable Register	0.51	ns
$t_{OEHD}$	Data Hold Time for the Output Enable Register	0.00	ns
$t_{OESUE}$	Enable Setup Time for the Output Enable Register	0.73	ns
$t_{OEHE}$	Enable Hold Time for the Output Enable Register	0.00	ns
$t_{OECLR2Q}$	Asynchronous Clear-to-Q of the Output Enable Register	1.13	ns
$t_{OEPRE2Q}$	Asynchronous Preset-to-Q of the Output Enable Register	1.13	ns
$t_{OEREMCLR}$	Asynchronous Clear Removal Time for the Output Enable Register	0.00	ns
$t_{OERECCLR}$	Asynchronous Clear Recovery Time for the Output Enable Register	0.24	ns
$t_{OEREMPRES}$	Asynchronous Preset Removal Time for the Output Enable Register	0.00	ns
$t_{OERECPRE}$	Asynchronous Preset Recovery Time for the Output Enable Register	0.24	ns
$t_{OEWCCLR}$	Asynchronous Clear Minimum Pulse Width for the Output Enable Register	0.19	ns
$t_{OEWPRE}$	Asynchronous Preset Minimum Pulse Width for the Output Enable Register	0.19	ns
$t_{OECKMPWH}$	Clock Minimum Pulse Width HIGH for the Output Enable Register	0.31	ns
$t_{OECKMPWL}$	Clock Minimum Pulse Width LOW for the Output Enable Register	0.28	ns

*Note:* For specific junction temperature and voltage supply levels, refer to [Table 2-6](#) on page 2-6 for derating values.

### 1.2 V DC Core Voltage

**Table 2-128 • Output Enable Register Propagation Delays**  
**Commercial-Case Conditions:  $T_J = 70^\circ\text{C}$ , Worst-Case  $V_{CC} = 1.14\text{ V}$**

Parameter	Description	Std.	Units
$t_{OECLKQ}$	Clock-to-Q of the Output Enable Register	1.10	ns
$t_{OESUD}$	Data Setup Time for the Output Enable Register	1.15	ns
$t_{OEHD}$	Data Hold Time for the Output Enable Register	0.00	ns
$t_{OESUE}$	Enable Setup Time for the Output Enable Register	1.22	ns
$t_{OEHE}$	Enable Hold Time for the Output Enable Register	0.00	ns
$t_{OECLR2Q}$	Asynchronous Clear-to-Q of the Output Enable Register	1.65	ns
$t_{OEPRE2Q}$	Asynchronous Preset-to-Q of the Output Enable Register	1.65	ns
$t_{OEREMCLR}$	Asynchronous Clear Removal Time for the Output Enable Register	0.00	ns
$t_{OERECCLR}$	Asynchronous Clear Recovery Time for the Output Enable Register	0.24	ns
$t_{OEREMPRE}$	Asynchronous Preset Removal Time for the Output Enable Register	0.00	ns
$t_{OERECPRE}$	Asynchronous Preset Recovery Time for the Output Enable Register	0.24	ns
$t_{OEWCCLR}$	Asynchronous Clear Minimum Pulse Width for the Output Enable Register	0.19	ns
$t_{OEWPRES}$	Asynchronous Preset Minimum Pulse Width for the Output Enable Register	0.19	ns
$t_{OECKMPWH}$	Clock Minimum Pulse Width HIGH for the Output Enable Register	0.31	ns
$t_{OECKMPWL}$	Clock Minimum Pulse Width LOW for the Output Enable Register	0.28	ns

*Note:* For specific junction temperature and voltage supply levels, refer to [Table 2-7 on page 2-6](#) for derating values.

## DDR Module Specifications

### Input DDR Module

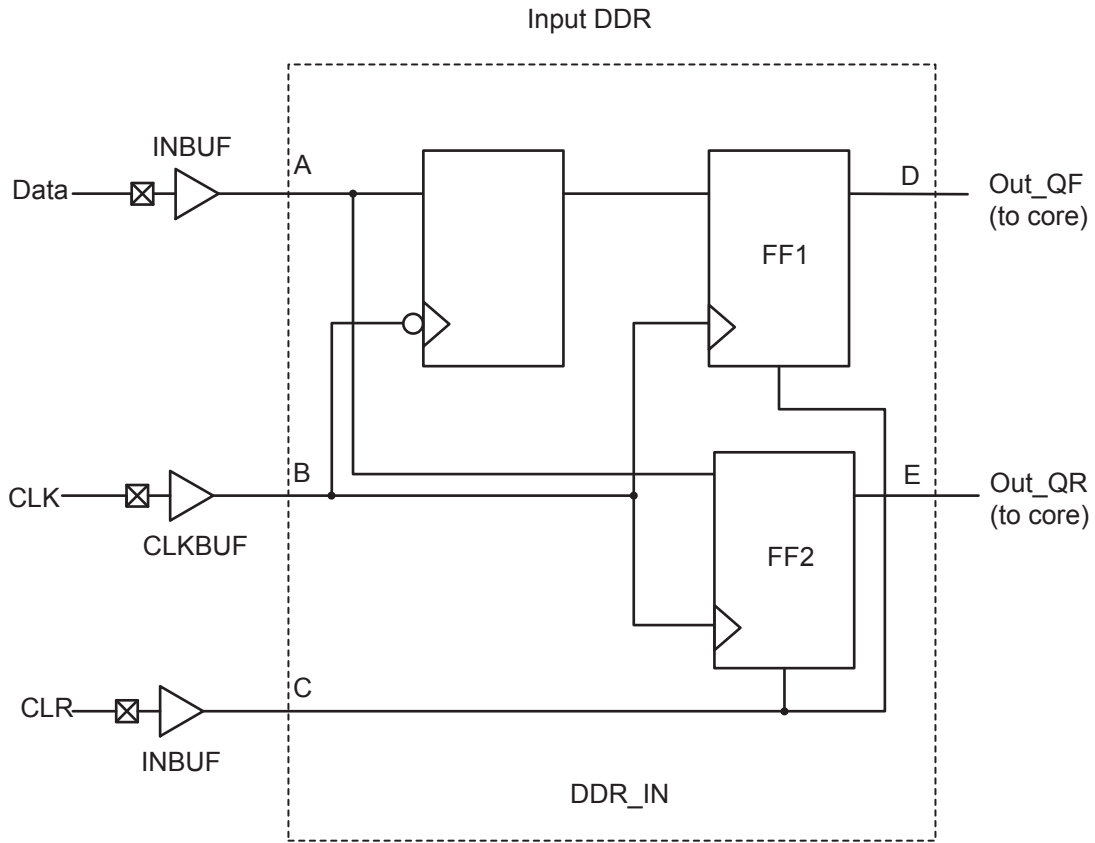

**Figure 2-31 • Input DDR Timing Model**

**Table 2-129 • Parameter Definitions**

Parameter Name	Parameter Definition	Measuring Nodes (from, to)
$t_{DDRICKQ1}$	Clock-to-Out Out_QR	B, D
$t_{DDRICKQ2}$	Clock-to-Out Out_QF	B, E
$t_{DDRISUD}$	Data Setup Time of DDR input	A, B
$t_{DDRILD}$	Data Hold Time of DDR input	A, B
$t_{DDRICLR2Q1}$	Clear-to-Out Out_QR	C, D
$t_{DDRICLR2Q2}$	Clear-to-Out Out_QF	C, E
$t_{DDRIREMCLR}$	Clear Removal	C, B
$t_{DDRIRECCLR}$	Clear Recovery	C, B

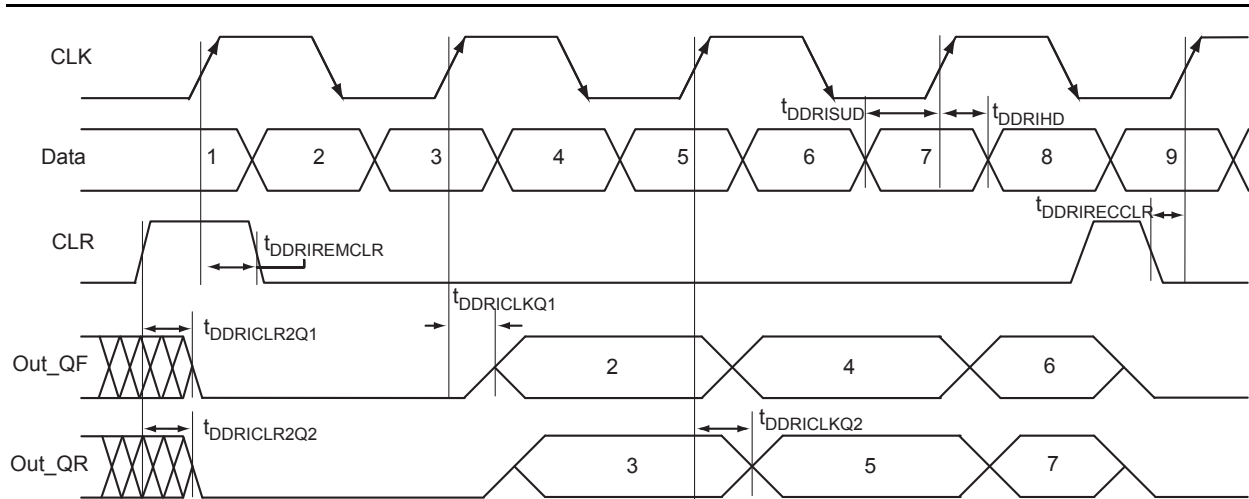

**Figure 2-32 • Input DDR Timing Diagram**

**Timing Characteristics**

**1.5 V DC Core Voltage**

**Table 2-130 • Input DDR Propagation Delays**

**Commercial-Case Conditions:  $T_J = 70^\circ\text{C}$ , Worst-Case  $V_{CC} = 1.425\text{ V}$**

Parameter	Description	Std.	Units
$t_{\text{DDRICKQ1}}$	Clock-to-Out Out_QR for Input DDR	0.48	ns
$t_{\text{DDRICKQ2}}$	Clock-to-Out Out_QF for Input DDR	0.65	ns
$t_{\text{DDRISUD1}}$	Data Setup for Input DDR (negedge)	0.50	ns
$t_{\text{DDRISUD2}}$	Data Setup for Input DDR (posedge)	0.40	ns
$t_{\text{DDRHD1}}$	Data Hold for Input DDR (negedge)	0.00	ns
$t_{\text{DDRHD2}}$	Data Hold for Input DDR (posedge)	0.00	ns
$t_{\text{DDRICLR2Q1}}$	Asynchronous Clear to Out Out_QR for Input DDR	0.82	ns
$t_{\text{DDRICLR2Q2}}$	Asynchronous Clear-to-Out Out_QF for Input DDR	0.98	ns
$t_{\text{DDRIREMCLR}}$	Asynchronous Clear Removal Time for Input DDR	0.00	ns
$t_{\text{DDRIRECCLR}}$	Asynchronous Clear Recovery Time for Input DDR	0.23	ns
$t_{\text{DDRiwCLR}}$	Asynchronous Clear Minimum Pulse Width for Input DDR	0.19	ns
$t_{\text{DDRICKMPWH}}$	Clock Minimum Pulse Width HIGH for Input DDR	0.31	ns
$t_{\text{DDRICKMPWL}}$	Clock Minimum Pulse Width LOW for Input DDR	0.28	ns
$F_{\text{DDRIMAX}}$	Maximum Frequency for Input DDR	250.00	MHz

*Note:* For specific junction temperature and voltage supply levels, refer to Table 2-6 on page 2-6 for derating values.

### 1.2 V DC Core Voltage

**Table 2-131 • Input DDR Propagation Delays**  
 Commercial-Case Conditions:  $T_J = 70^\circ\text{C}$ , Worst-Case  $V_{CC} = 1.14\text{ V}$

Parameter	Description	Std.	Units
$t_{\text{DDRICKQ1}}$	Clock-to-Out Out_QR for Input DDR	0.76	ns
$t_{\text{DDRICKQ2}}$	Clock-to-Out Out_QF for Input DDR	0.94	ns
$t_{\text{DDRISUD1}}$	Data Setup for Input DDR (negedge)	0.93	ns
$t_{\text{DDRISUD2}}$	Data Setup for Input DDR (posedge)	0.84	ns
$t_{\text{DDRILD1}}$	Data Hold for Input DDR (negedge)	0.00	ns
$t_{\text{DDRILD2}}$	Data Hold for Input DDR (posedge)	0.00	ns
$t_{\text{DDRICLR2Q1}}$	Asynchronous Clear to Out Out_QR for Input DDR	1.23	ns
$t_{\text{DDRICLR2Q2}}$	Asynchronous Clear-to-Out Out_QF for Input DDR	1.42	ns
$t_{\text{DDRIREMCLR}}$	Asynchronous Clear Removal Time for Input DDR	0.00	ns
$t_{\text{DDRIRECCLR}}$	Asynchronous Clear Recovery Time for Input DDR	0.24	ns
$t_{\text{DDRILWCLR}}$	Asynchronous Clear Minimum Pulse Width for Input DDR	0.19	ns
$t_{\text{DDRICKMPWH}}$	Clock Minimum Pulse Width HIGH for Input DDR	0.31	ns
$t_{\text{DDRICKMPWL}}$	Clock Minimum Pulse Width LOW for Input DDR	0.28	ns
$F_{\text{DDRIMAX}}$	Maximum Frequency for Input DDR	160.00	MHz

*Note:* For specific junction temperature and voltage supply levels, refer to [Table 2-7 on page 2-6](#) for derating values.

## Output DDR Module

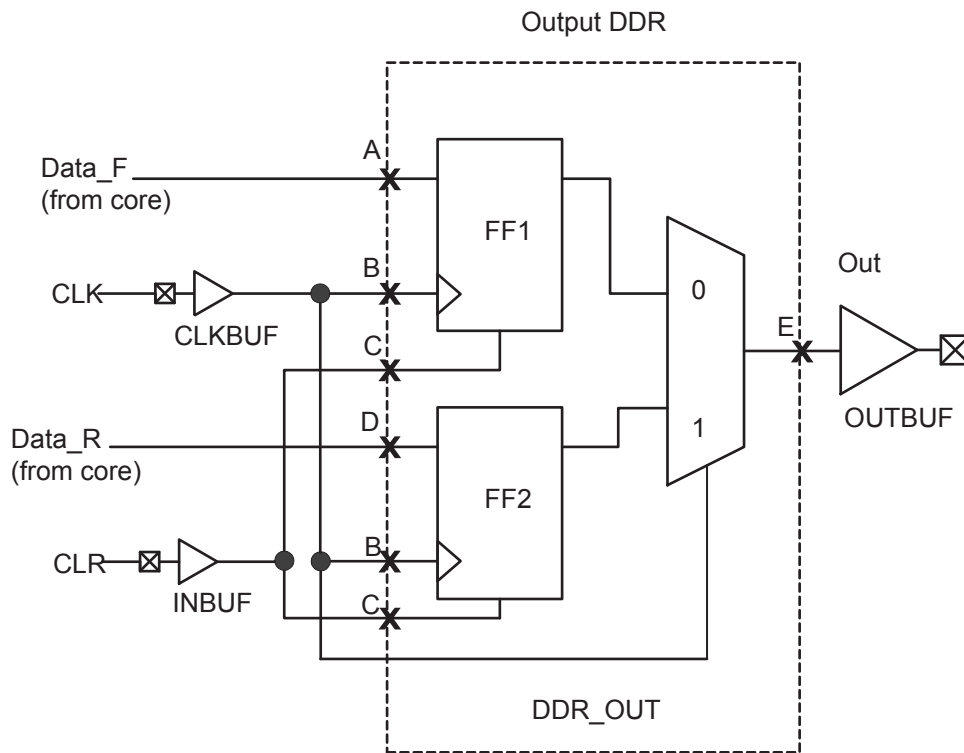

**Figure 2-33 • Output DDR Timing Model**

**Table 2-132 • Parameter Definitions**

Parameter Name	Parameter Definition	Measuring Nodes (from, to)
$t_{DDROCLKQ}$	Clock-to-Out	B, E
$t_{DDROCLR2Q}$	Asynchronous Clear-to-Out	C, E
$t_{DDROREMCLR}$	Clear Removal	C, B
$t_{DDRORECCLR}$	Clear Recovery	C, B
$t_{DDROSUD1}$	Data Setup Data_F	A, B
$t_{DDROSUD2}$	Data Setup Data_R	D, B
$t_{DDROHD1}$	Data Hold Data_F	A, B
$t_{DDROHD2}$	Data Hold Data_R	D, B

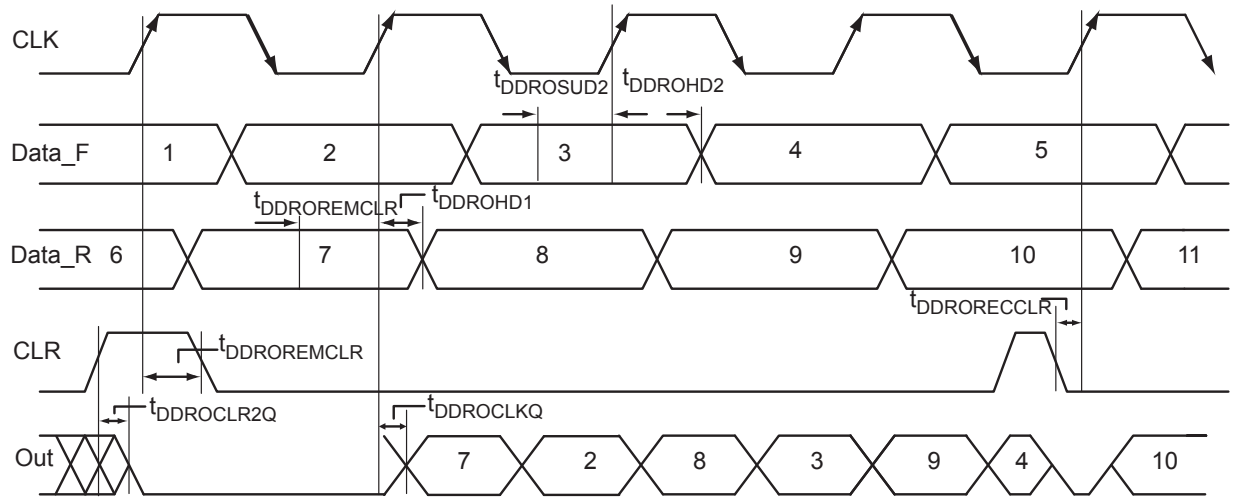

**Figure 2-34 • Output DDR Timing Diagram**

## Timing Characteristics

### 1.5 V DC Core Voltage

**Table 2-133 • Output DDR Propagation Delays**  
 Commercial-Case Conditions:  $T_J = 70^\circ\text{C}$ , Worst-Case VCC = 1.425 V

Parameter	Description	Std.	Units
$t_{\text{DDROCLKQ}}$	Clock-to-Out of DDR for Output DDR	1.07	ns
$t_{\text{DDROSUD1}}$	Data_F Data Setup for Output DDR	0.67	ns
$t_{\text{DDROSUD2}}$	Data_R Data Setup for Output DDR	0.67	ns
$t_{\text{DDROHD1}}$	Data_F Data Hold for Output DDR	0.00	ns
$t_{\text{DDROHD2}}$	Data_R Data Hold for Output DDR	0.00	ns
$t_{\text{DDROCLR2Q}}$	Asynchronous Clear-to-Out for Output DDR	1.38	ns
$t_{\text{DDROREMCLR}}$	Asynchronous Clear Removal Time for Output DDR	0.00	ns
$t_{\text{DDRORECCLR}}$	Asynchronous Clear Recovery Time for Output DDR	0.23	ns
$t_{\text{DDROWCLR1}}$	Asynchronous Clear Minimum Pulse Width for Output DDR	0.19	ns
$t_{\text{DDROCKMPWH}}$	Clock Minimum Pulse Width HIGH for the Output DDR	0.31	ns
$t_{\text{DDROCKMPWL}}$	Clock Minimum Pulse Width LOW for the Output DDR	0.28	ns
$F_{\text{DDOMAX}}$	Maximum Frequency for the Output DDR	250.00	MHz

*Note:* For specific junction temperature and voltage supply levels, refer to [Table 2-6 on page 2-6](#) for derating values.

### 1.2 V DC Core Voltage

**Table 2-134 • Output DDR Propagation Delays**  
 Commercial-Case Conditions:  $T_J = 70^\circ\text{C}$ , Worst-Case VCC = 1.14 V

Parameter	Description	Std.	Units
$t_{\text{DDROCLKQ}}$	Clock-to-Out of DDR for Output DDR	1.60	ns
$t_{\text{DDROSUD1}}$	Data_F Data Setup for Output DDR	1.09	ns
$t_{\text{DDROSUD2}}$	Data_R Data Setup for Output DDR	1.16	ns
$t_{\text{DDROHD1}}$	Data_F Data Hold for Output DDR	0.00	ns
$t_{\text{DDROHD2}}$	Data_R Data Hold for Output DDR	0.00	ns
$t_{\text{DDROCLR2Q}}$	Asynchronous Clear-to-Out for Output DDR	1.99	ns
$t_{\text{DDROREMCLR}}$	Asynchronous Clear Removal Time for Output DDR	0.00	ns
$t_{\text{DDRORECCLR}}$	Asynchronous Clear Recovery Time for Output DDR	0.24	ns
$t_{\text{DDROWCLR1}}$	Asynchronous Clear Minimum Pulse Width for Output DDR	0.19	ns
$t_{\text{DDROCKMPWH}}$	Clock Minimum Pulse Width HIGH for the Output DDR	0.31	ns
$t_{\text{DDROCKMPWL}}$	Clock Minimum Pulse Width LOW for the Output DDR	0.28	ns
$F_{\text{DDOMAX}}$	Maximum Frequency for the Output DDR	160.00	MHz

*Note:* For specific junction temperature and voltage supply levels, refer to [Table 2-7 on page 2-6](#) for derating values.

## VersaTile Characteristics

### VersaTile Specifications as a Combinatorial Module

The IGLOOe library offers all combinations of LUT-3 combinatorial functions. In this section, timing characteristics are presented for a sample of the library. For more details, refer to the *IGLOO, Fusion, and ProASIC3 Macro Library Guide*.

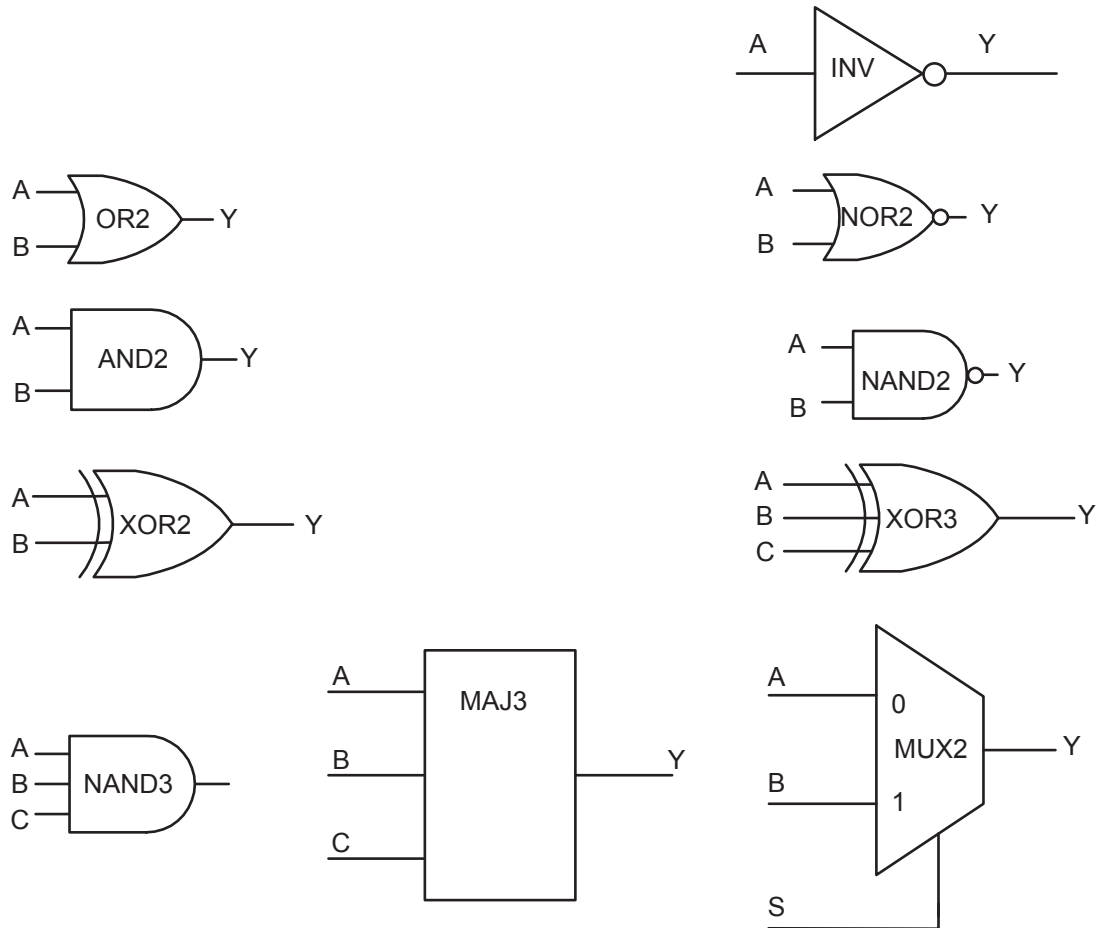

Figure 2-35 • Sample of Combinatorial Cells

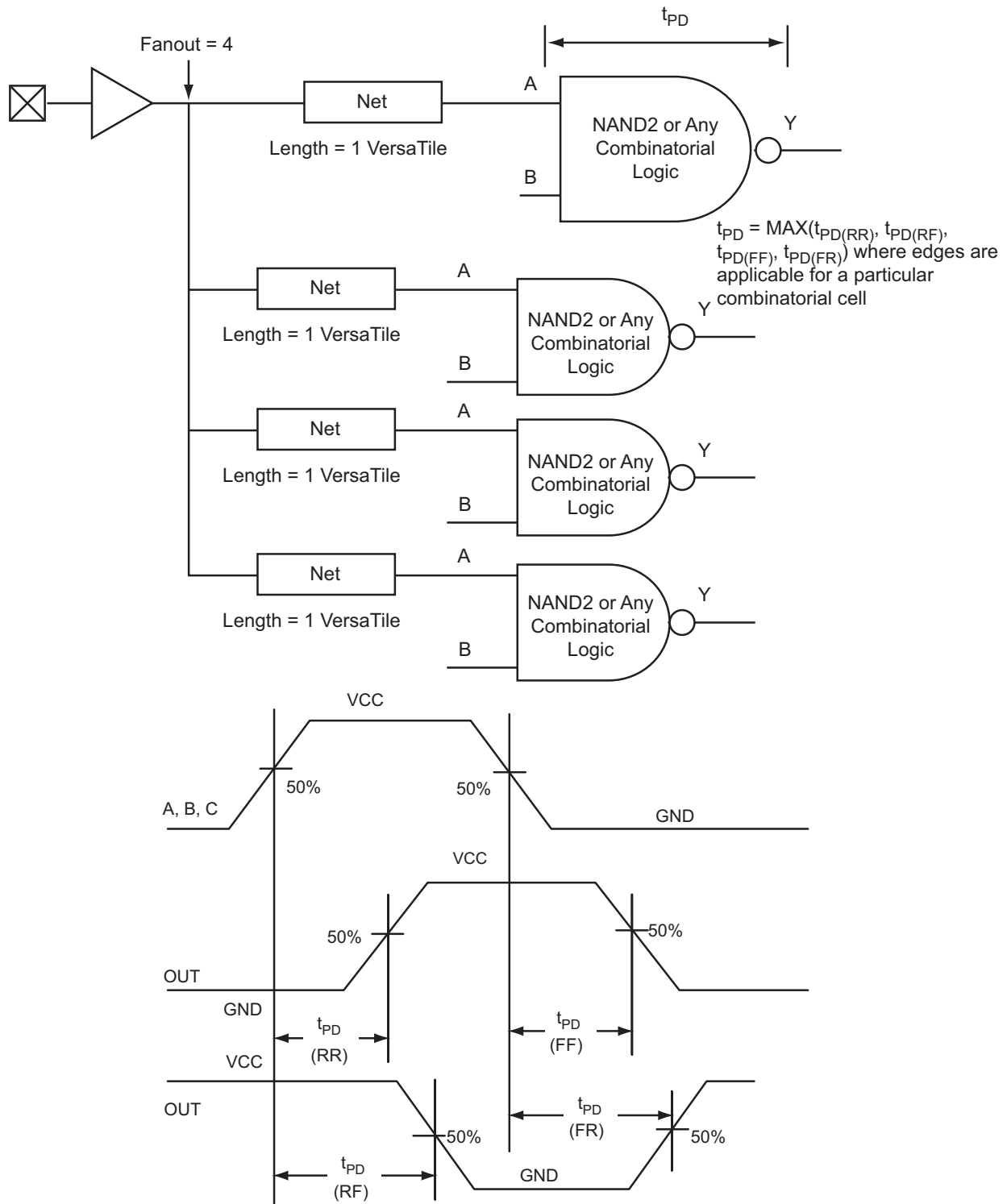

Figure 2-36 • Timing Model and Waveforms

## Timing Characteristics

### 1.5 V DC Core Voltage

**Table 2-135 • Combinatorial Cell Propagation Delays**  
 Commercial-Case Conditions:  $T_J = 70^\circ\text{C}$ , Worst-Case VCC = 1.425 V

Combinatorial Cell	Equation	Parameter	Std.	Units
INV	$Y = !A$	$t_{PD}$	0.80	ns
AND2	$Y = A \cdot B$	$t_{PD}$	0.84	ns
NAND2	$Y = !(A \cdot B)$	$t_{PD}$	0.90	ns
OR2	$Y = A + B$	$t_{PD}$	1.19	ns
NOR2	$Y = !(A + B)$	$t_{PD}$	1.10	ns
XOR2	$Y = A \oplus B$	$t_{PD}$	1.37	ns
MAJ3	$Y = \text{MAJ}(A, B, C)$	$t_{PD}$	1.33	ns
XOR3	$Y = A \oplus B \oplus C$	$t_{PD}$	1.79	ns
MUX2	$Y = A !S + B S$	$t_{PD}$	1.48	ns
AND3	$Y = A \cdot B \cdot C$	$t_{PD}$	1.21	ns

*Note:* For specific junction temperature and voltage supply levels, refer to [Table 2-6 on page 2-6](#) for derating values.

### 1.2 V DC Core Voltage

**Table 2-136 • Combinatorial Cell Propagation Delays**  
 Commercial-Case Conditions:  $T_J = 70^\circ\text{C}$ , Worst-Case VCC = 1.425 V

Combinatorial Cell	Equation	Parameter	Std.	Units
INV	$Y = !A$	$t_{PD}$	1.35	ns
AND2	$Y = A \cdot B$	$t_{PD}$	1.42	ns
NAND2	$Y = !(A \cdot B)$	$t_{PD}$	1.58	ns
OR2	$Y = A + B$	$t_{PD}$	2.10	ns
NOR2	$Y = !(A + B)$	$t_{PD}$	1.94	ns
XOR2	$Y = A \oplus B$	$t_{PD}$	2.33	ns
MAJ3	$Y = \text{MAJ}(A, B, C)$	$t_{PD}$	2.34	ns
XOR3	$Y = A \oplus B \oplus C$	$t_{PD}$	3.05	ns
MUX2	$Y = A !S + B S$	$t_{PD}$	2.64	ns
AND3	$Y = A \cdot B \cdot C$	$t_{PD}$	2.10	ns

*Note:* For specific junction temperature and voltage supply levels, refer to [Table 2-7 on page 2-6](#) for derating values.

## VersaTile Specifications as a Sequential Module

The IGLOOe library offers a wide variety of sequential cells, including flip-flops and latches. Each has a data input and optional enable, clear, or preset. In this section, timing characteristics are presented for a representative sample from the library. For more details, refer to the *IGLOO, Fusion, and ProASIC3 Macro Library Guide*.

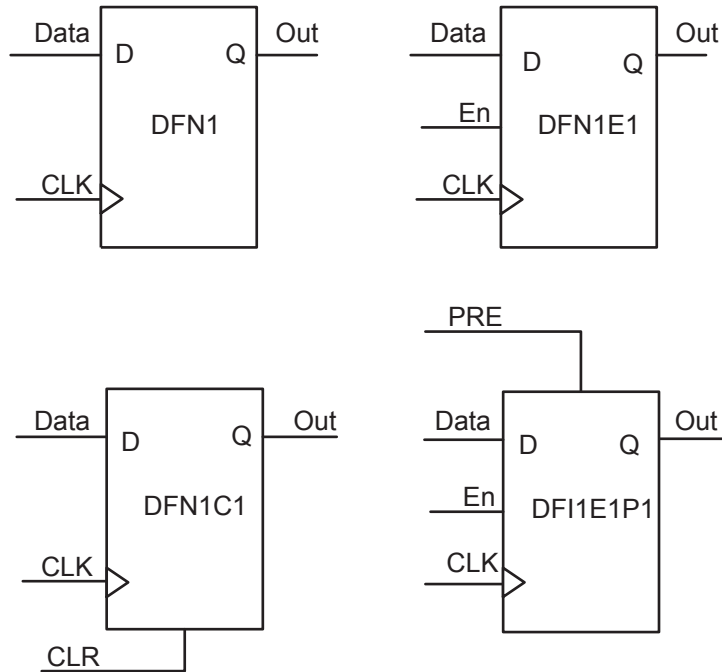

**Figure 2-37 • Sample of Sequential Cells**

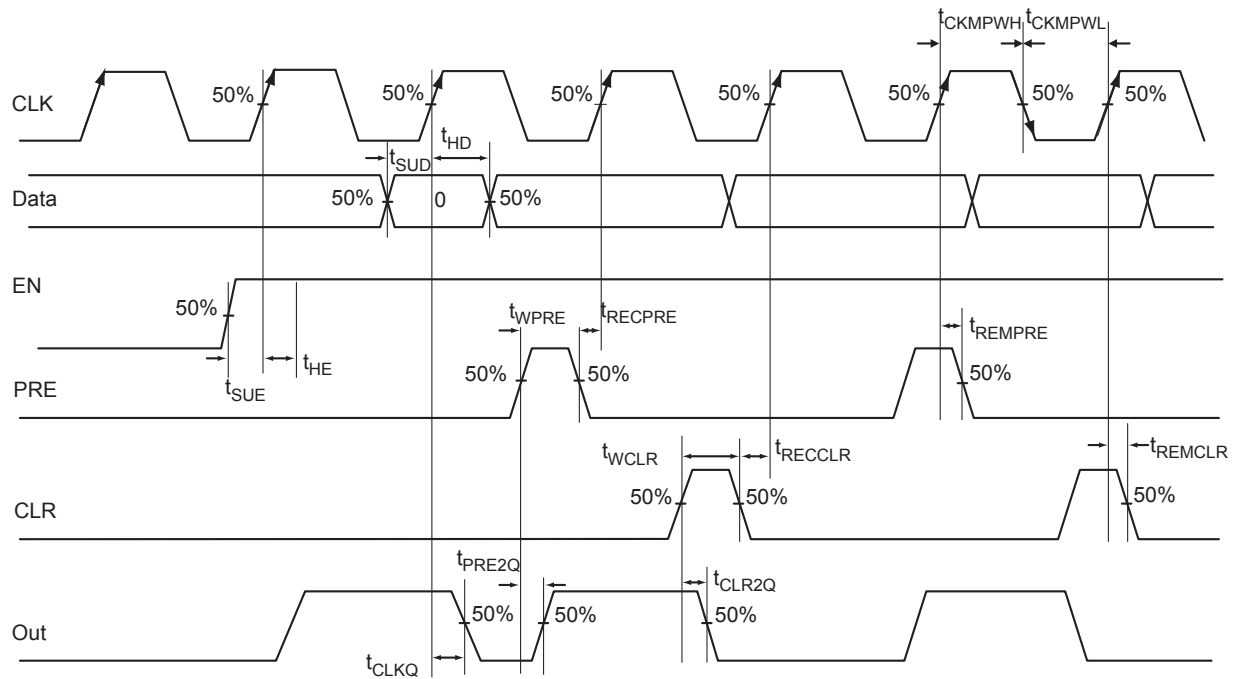

**Figure 2-38 • Timing Model and Waveforms**

### Timing Characteristics 1.5 V DC Core Voltage

**Table 2-137 • Register Delays**  
Commercial-Case Conditions:  $T_J = 70^\circ\text{C}$ , Worst-Case  $V_{CC} = 1.425\text{ V}$

Parameter	Description	Std.	Units
$t_{CLKQ}$	Clock-to-Q of the Core Register	0.89	ns
$t_{SUD}$	Data Setup Time for the Core Register	0.81	ns
$t_{HD}$	Data Hold Time for the Core Register	0.00	ns
$t_{SUE}$	Enable Setup Time for the Core Register	0.73	ns
$t_{HE}$	Enable Hold Time for the Core Register	0.00	ns
$t_{CLR2Q}$	Asynchronous Clear-to-Q of the Core Register	0.60	ns
$t_{PRE2Q}$	Asynchronous Preset-to-Q of the Core Register	0.62	ns
$t_{REMCLR}$	Asynchronous Clear Removal Time for the Core Register	0.00	ns
$t_{RECCLR}$	Asynchronous Clear Recovery Time for the Core Register	0.24	ns
$t_{REMPRE}$	Asynchronous Preset Removal Time for the Core Register	0.00	ns
$t_{RECPRE}$	Asynchronous Preset Recovery Time for the Core Register	0.23	ns
$t_{WCLR}$	Asynchronous Clear Minimum Pulse Width for the Core Register	0.30	ns
$t_{WPRE}$	Asynchronous Preset Minimum Pulse Width for the Core Register	0.30	ns
$t_{CKMPWH}$	Clock Minimum Pulse Width HIGH for the Core Register	0.56	ns
$t_{CKMPWL}$	Clock Minimum Pulse Width LOW for the Core Register	0.56	ns

*Note:* For specific junction temperature and voltage supply levels, refer to Table 2-6 on page 2-6 for derating values.

## 1.2 V DC Core Voltage

**Table 2-138 • Register Delays**  
 Commercial-Case Conditions:  $T_J = 70^\circ\text{C}$ , Worst-Case  $V_{CC} = 1.14\text{ V}$

Parameter	Description	Std.	Units
$t_{\text{CLKQ}}$	Clock-to-Q of the Core Register	1.61	ns
$t_{\text{SUD}}$	Data Setup Time for the Core Register	1.17	ns
$t_{\text{HD}}$	Data Hold Time for the Core Register	0.00	ns
$t_{\text{SUE}}$	Enable Setup Time for the Core Register	1.29	ns
$t_{\text{HE}}$	Enable Hold Time for the Core Register	0.00	ns
$t_{\text{CLR2Q}}$	Asynchronous Clear-to-Q of the Core Register	0.87	ns
$t_{\text{PRE2Q}}$	Asynchronous Preset-to-Q of the Core Register	0.89	ns
$t_{\text{REMCLR}}$	Asynchronous Clear Removal Time for the Core Register	0.00	ns
$t_{\text{RECCLR}}$	Asynchronous Clear Recovery Time for the Core Register	0.24	ns
$t_{\text{REMPRE}}$	Asynchronous Preset Removal Time for the Core Register	0.00	ns
$t_{\text{RECPRE}}$	Asynchronous Preset Recovery Time for the Core Register	0.24	ns
$t_{\text{WCLR}}$	Asynchronous Clear Minimum Pulse Width for the Core Register	0.46	ns
$t_{\text{WPRE}}$	Asynchronous Preset Minimum Pulse Width for the Core Register	0.46	ns
$t_{\text{CKMPWH}}$	Clock Minimum Pulse Width HIGH for the Core Register	0.95	ns
$t_{\text{CKMPWL}}$	Clock Minimum Pulse Width LOW for the Core Register	0.95	ns

*Note:* For specific junction temperature and voltage supply levels, refer to [Table 2-7 on page 2-6](#) for derating values.

## Global Resource Characteristics

### AGLE600 Clock Tree Topology

Clock delays are device-specific. Figure 2-39 is an example of a global tree used for clock routing. The global tree presented in Figure 2-39 is driven by a CCC located on the west side of the AGLE600 device. It is used to drive all D-flip-flops in the device.

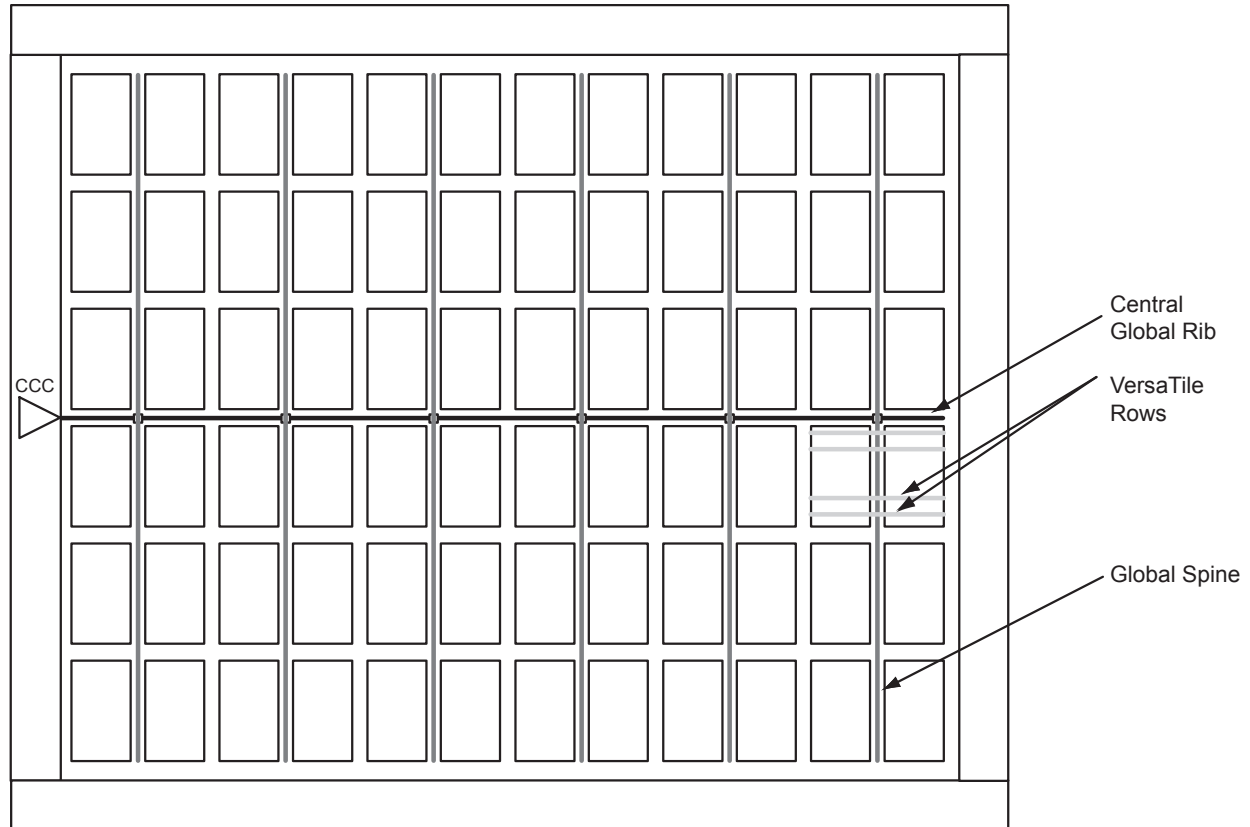

Figure 2-39 • Example of Global Tree Use in an AGLE600 Device for Clock Routing

## Global Tree Timing Characteristics

Global clock delays include the central rib delay, the spine delay, and the row delay. Delays do not include I/O input buffer clock delays, as these are I/O standard-dependent, and the clock may be driven and conditioned internally by the CCC module. For more details on clock conditioning capabilities, refer to the "Clock Conditioning Circuits" section on page 2-91. Table 2-139 and Table 2-141 present minimum and maximum global clock delays within the device. Minimum and maximum delays are measured with minimum and maximum loading.

### Timing Characteristics

#### 1.5 V DC Core Voltage

**Table 2-139 • AGLE600 Global Resource**  
Commercial-Case Conditions:  $T_J = 70^\circ\text{C}$ ,  $V_{CC} = 1.425\text{ V}$

Parameter	Description	Std.		Units
		Min. <sup>1</sup>	Max. <sup>2</sup>	
$t_{RCKL}$	Input Low Delay for Global Clock	1.48	1.82	ns
$t_{RCKH}$	Input High Delay for Global Clock	1.52	1.94	ns
$t_{RCKMPWH}$	Minimum Pulse Width High for Global Clock	1.18		ns
$t_{RCKMPWL}$	Minimum Pulse Width Low for Global Clock	1.15		ns
$t_{RCKSW}$	Maximum Skew for Global Clock		0.42	ns

#### Notes:

1. Value reflects minimum load. The delay is measured from the CCC output to the clock pin of a sequential element, located in a lightly loaded row (single element is connected to the global net).
2. Value reflects maximum load. The delay is measured on the clock pin of the farthest sequential element, located in a fully loaded row (all available flip-flops are connected to the global net in the row).
3. For specific junction temperature and voltage supply levels, refer to Table 2-6 on page 2-6 for derating values.

**Table 2-140 • AGLE3000 Global Resource**  
Commercial-Case Conditions:  $T_J = 70^\circ\text{C}$ ,  $V_{CC} = 1.425\text{ V}$

Parameter	Description	Std.		Units
		Min. <sup>1</sup>	Max. <sup>2</sup>	
$t_{RCKL}$	Input Low Delay for Global Clock	2.00	2.34	ns
$t_{RCKH}$	Input High Delay for Global Clock	2.09	2.51	ns
$t_{RCKMPWH}$	Minimum Pulse Width High for Global Clock	1.18		ns
$t_{RCKMPWL}$	Minimum Pulse Width Low for Global Clock	1.15		ns
$t_{RCKSW}$	Maximum Skew for Global Clock		0.42	ns

#### Notes:

1. Value reflects minimum load. The delay is measured from the CCC output to the clock pin of a sequential element, located in a lightly loaded row (single element is connected to the global net).
2. Value reflects maximum load. The delay is measured on the clock pin of the farthest sequential element, located in a fully loaded row (all available flip-flops are connected to the global net in the row).
3. For specific junction temperature and voltage supply levels, refer to Table 2-6 on page 2-6 for derating values.

### 1.2 V DC Core Voltage

**Table 2-141 • AGLE600 Global Resource**  
 Commercial-Case Conditions:  $T_J = 70^\circ\text{C}$ ,  $V_{CC} = 1.14\text{ V}$

Parameter	Description	Std.		Units
		Min. <sup>1</sup>	Max. <sup>2</sup>	
$t_{RCKL}$	Input Low Delay for Global Clock	2.22	2.67	ns
$t_{RCKH}$	Input High Delay for Global Clock	2.32	2.93	ns
$t_{RCKMPWH}$	Minimum Pulse Width HIGH for Global Clock	1.40		ns
$t_{RCKMPWL}$	Minimum Pulse Width LOW for Global Clock	1.65		ns
$t_{RCKSW}$	Maximum Skew for Global Clock		0.61	ns

**Notes:**

1. Value reflects minimum load. The delay is measured from the CCC output to the clock pin of a sequential element, located in a lightly loaded row (single element is connected to the global net).
2. Value reflects maximum load. The delay is measured on the clock pin of the farthest sequential element, located in a fully loaded row (all available flip-flops are connected to the global net in the row).
3. For specific junction temperature and voltage supply levels, refer to [Table 2-7 on page 2-6](#) for derating values.

**Table 2-142 • AGLE3000 Global Resource**  
 Commercial-Case Conditions:  $T_J = 70^\circ\text{C}$ ,  $V_{CC} = 1.14\text{ V}$

Parameter	Description	Std.		Units
		Min. <sup>1</sup>	Max. <sup>2</sup>	
$t_{RCKL}$	Input Low Delay for Global Clock	2.83	3.27	ns
$t_{RCKH}$	Input High Delay for Global Clock	3.00	3.61	ns
$t_{RCKMPWH}$	Minimum Pulse Width HIGH for Global Clock	1.40		ns
$t_{RCKMPWL}$	Minimum Pulse Width LOW for Global Clock	1.65		ns
$t_{RCKSW}$	Maximum Skew for Global Clock		0.61	ns

**Notes:**

1. Value reflects minimum load. The delay is measured from the CCC output to the clock pin of a sequential element, located in a lightly loaded row (single element is connected to the global net).
2. Value reflects maximum load. The delay is measured on the clock pin of the farthest sequential element, located in a fully loaded row (all available flip-flops are connected to the global net in the row).
3. For specific junction temperature and voltage supply levels, refer to [Table 2-7 on page 2-6](#) for derating values.

## Clock Conditioning Circuits

### CCC Electrical Specifications

#### Timing Characteristics

**Table 2-143 • IGLOOe CCC/PLL Specification**  
For IGLOOe V2 or V5 Devices, 1.5 V DC Core Supply Voltage

Parameter	Min.	Typ.	Max.	Units	
Clock Conditioning Circuitry Input Frequency $f_{IN\_CCC}$	1.5		250	MHz	
Clock Conditioning Circuitry Output Frequency $f_{OUT\_CCC}$	0.75		250	MHz	
Serial Clock (SCLK) for Dynamic PLL <sup>1</sup>			100	MHz	
Delay Increments in Programmable Delay Blocks <sup>2, 3</sup>		360 <sup>4</sup>		ps	
Number of Programmable Values in Each Programmable Delay Block			32	ns	
Input Cycle-to-Cycle Jitter (peak magnitude)			1		
CCC Output Peak-to-Peak Period Jitter $F_{CCC\_OUT}$	Max Peak-to-Peak Period Jitter				
		1 Global Network Used	External FB Used	3 Global Networks Used	
	0.75 MHz to 24 MHz	0.50%	0.75%	0.70%	
	24 MHz to 100 MHz	1.00%	1.50%	1.20%	
100 MHz to 250 MHz	2.50%	3.75%	2.75%		
Acquisition Time					
	LockControl = 0		300	μs	
	LockControl = 1		6.0	ms	
Tracking Jitter <sup>5</sup>					
	LockControl = 0		2.5	ns	
	LockControl = 1		1.5	ns	
Output Duty Cycle	48.5		51.5	%	
Delay Range in Block: Programmable Delay 1 <sup>2, 3, 6</sup>	1.25		15.65	ns	
Delay Range in Block: Programmable Delay 2 <sup>2, 3, 6</sup>	0.469		15.65	ns	
Delay Range in Block: Fixed Delay <sup>2, 3</sup>		3.5		ns	

**Notes:**

1. Maximum value obtained for a Std. speed grade device in Worst Case Commercial Conditions. For specific junction temperature and voltage supply levels, refer to Table 2-6 on page 2-6 for derating values.
2. This delay is a function of voltage and temperature. See Table 2-6 on page 2-6 and Table 2-7 on page 2-6 for deratings.
3.  $T_J = 25^\circ\text{C}$ ,  $V_{CC} = 1.5\text{ V}$
4. When the CCC/PLL core is generated by Microsemi core generator software, not all delay values of the specified delay increments are available. Refer to the Libero SoC Online Help associated with the core for more information.
5. Tracking jitter is defined as the variation in clock edge position of PLL outputs with reference to the PLL input clock edge. Tracking jitter does not measure the variation in PLL output period, which is covered by the period jitter parameter.
6. For definitions of Type 1 and Type 2, refer to the PLL Block Diagram in the "Clock Conditioning Circuits in IGLOO and ProASIC3 Devices" chapter of the IGLOOe FPGA Fabric User's Guide.

**Table 2-144 • IGLOOe CCC/PLL Specification**  
**For IGLOOe V2 Devices, 1.2 V DC Core Supply Voltage**

Parameter	Min.	Typ.	Max.	Units
Clock Conditioning Circuitry Input Frequency $f_{IN\_CCC}$	1.5		160	MHz
Clock Conditioning Circuitry Output Frequency $f_{OUT\_CCC}$	0.75		160	MHz
Serial Clock (SCLK) for Dynamic PLL <sup>1</sup>			60	MHz
Delay Increments in Programmable Delay Blocks <sup>2, 3</sup>		580 <sup>4</sup>		ps
Number of Programmable Values in Each Programmable Delay Block			32	
Input Cycle-to-Cycle Jitter (peak magnitude)			0.25	ns
CCC Output Peak-to-Peak Period Jitter $F_{CCC\_OUT}$ <sup>5</sup>	Max Peak-to-Peak Period Jitter			
	1 Global Network Used	External FB Used	3 Global Networks Used	
0.75 MHz to 24 MHz	0.50%	0.75%	0.70%	
24 MHz to 100 MHz	1.00%	1.50%	1.20%	
100 MHz to 160 MHz	2.50%	3.75%	2.75%	
Acquisition Time				
	LockControl = 0		300	μs
	LockControl = 1		6.0	ms
Tracking Jitter <sup>6</sup>				
	LockControl = 0		4	ns
	LockControl = 1		3	ns
Output Duty Cycle	48.5		51.5	%
Delay Range in Block: Programmable Delay <sup>1, 2, 3, 7</sup>	2.3		20.86	ns
Delay Range in Block: Programmable Delay <sup>2, 3, 7</sup>	0.863		20.86	ns
Delay Range in Block: Fixed Delay <sup>2, 3</sup>		5.7		ns

**Notes:**

1. Maximum value obtained for a Std. speed grade device in Worst Case Commercial Conditions. For specific junction temperature and voltage supply levels, refer to [Table 2-6 on page 2-6](#) for derating values.
2. This delay is a function of voltage and temperature. See [Table 2-6 on page 2-6](#) and [Table 2-7 on page 2-6](#) for deratings.
3.  $T_j = 25^\circ\text{C}$ ,  $V_{CC} = 1.5\text{ V}$
4. When the CCC/PLL core is generated by Microsemi core generator software, not all delay values of the specified delay increments are available. Refer to the Libero SoC Online Help associated with the core for more information.
5. VCO output jitter is calculated as a percentage of the VCO frequency. The jitter (in ps) can be calculated by multiplying the VCO period by the per cent jitter. The VCO jitter (in ps) applies to CCC\_OUT regardless of the output divider settings. For example, if the jitter on VCO is 300 ps, the jitter on CCC\_OUT is also 300 ps, regardless of the output divider settings.
6. Tracking jitter is defined as the variation in clock edge position of PLL outputs with reference to PLL input clock edge. Tracking jitter does not measure the variation in PLL output period, which is covered by period jitter parameter.
7. For definitions of Type 1 and Type 2, refer to the PLL Block Diagram in the "Clock Conditioning Circuits in IGLOO and ProASIC3 Devices" chapter of the [IGLOOe FPGA Fabric User's Guide](#).

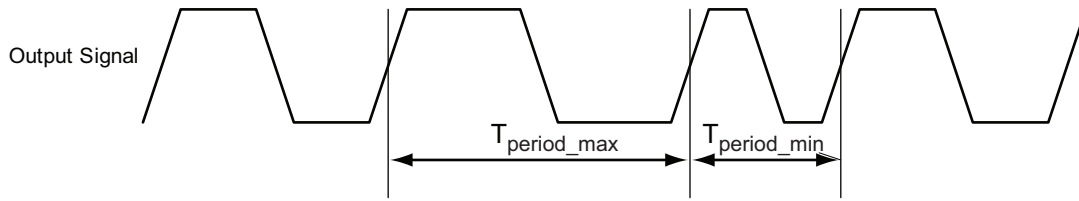

*Note:* Peak-to-peak jitter measurements are defined by  $T_{\text{peak-to-peak}} = T_{\text{period\_max}} - T_{\text{period\_min}}$ .

**Figure 2-40 • Peak-to-Peak Jitter Definition**

---

## Embedded SRAM and FIFO Characteristics

### SRAM

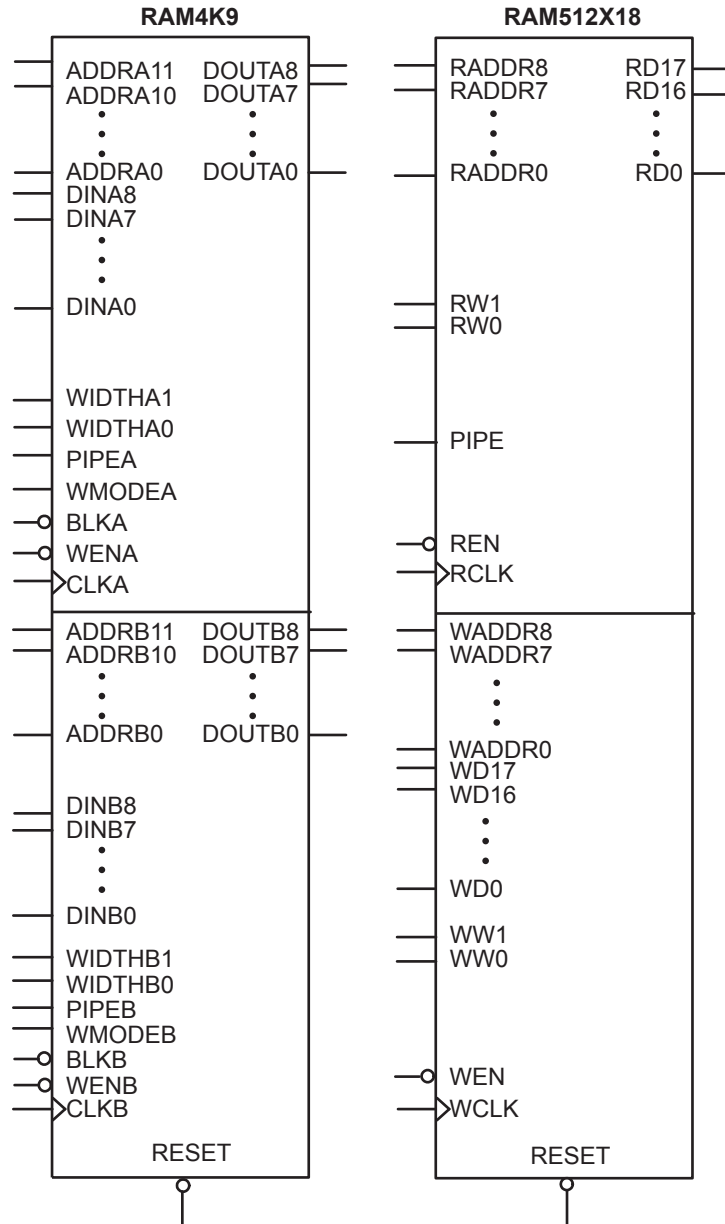

Figure 2-41 • RAM Models

### Timing Waveforms

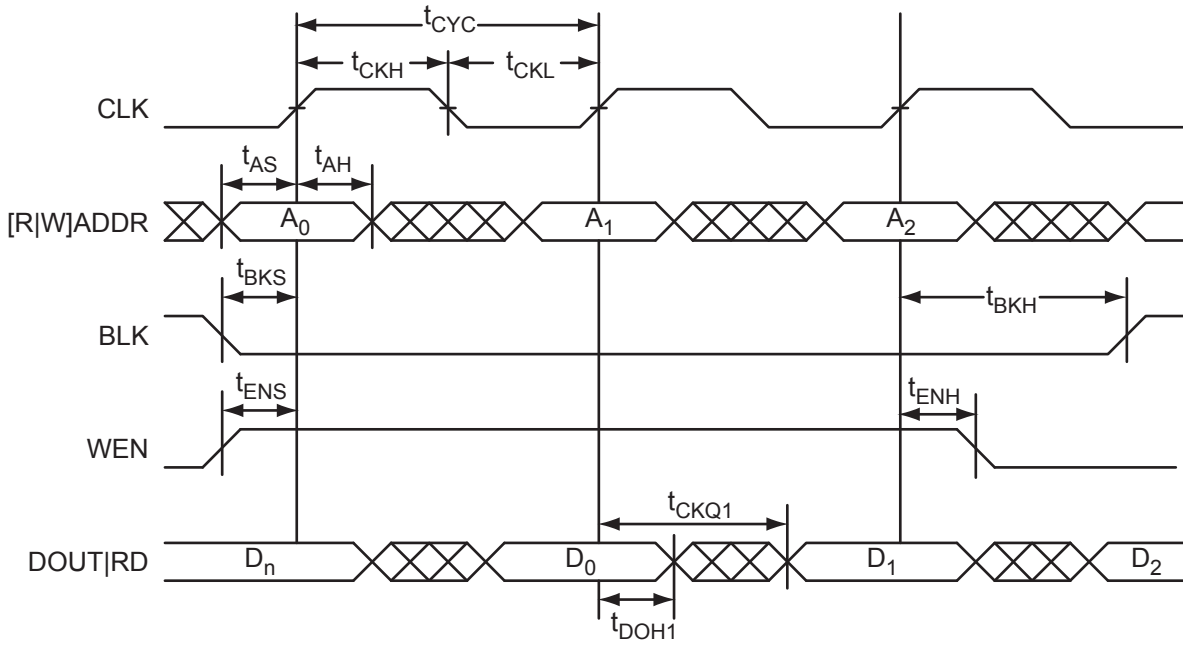

Figure 2-42 • RAM Read for Pass-Through Output. Applicable to Both RAM4K9 and RAM512X18.

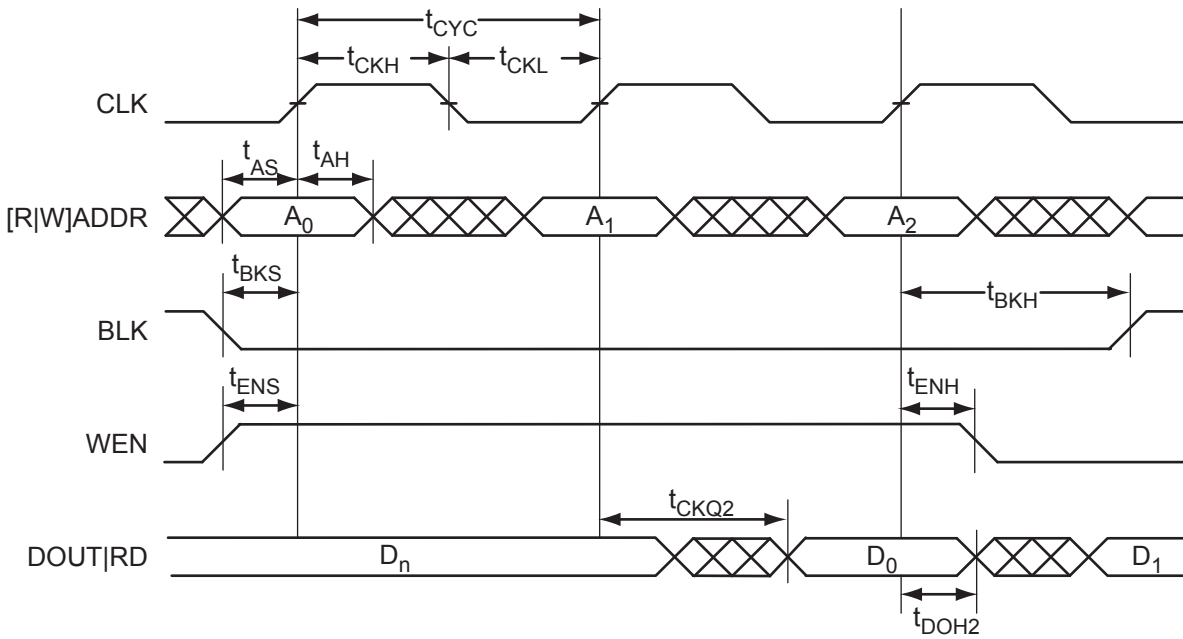
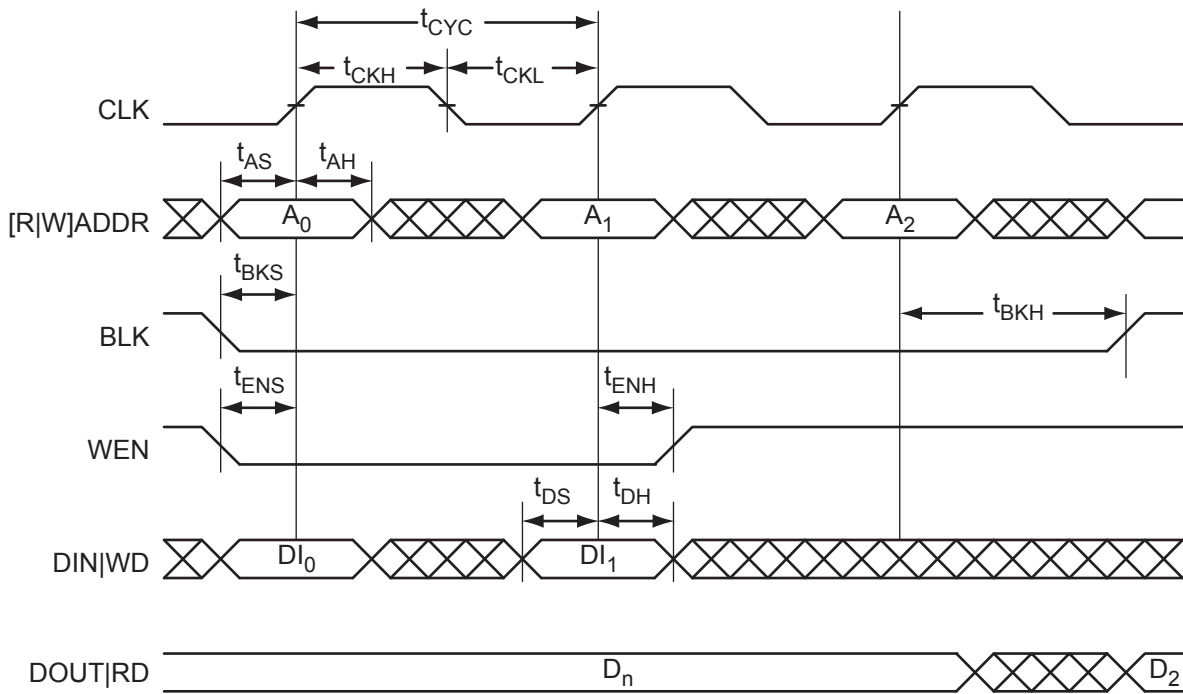
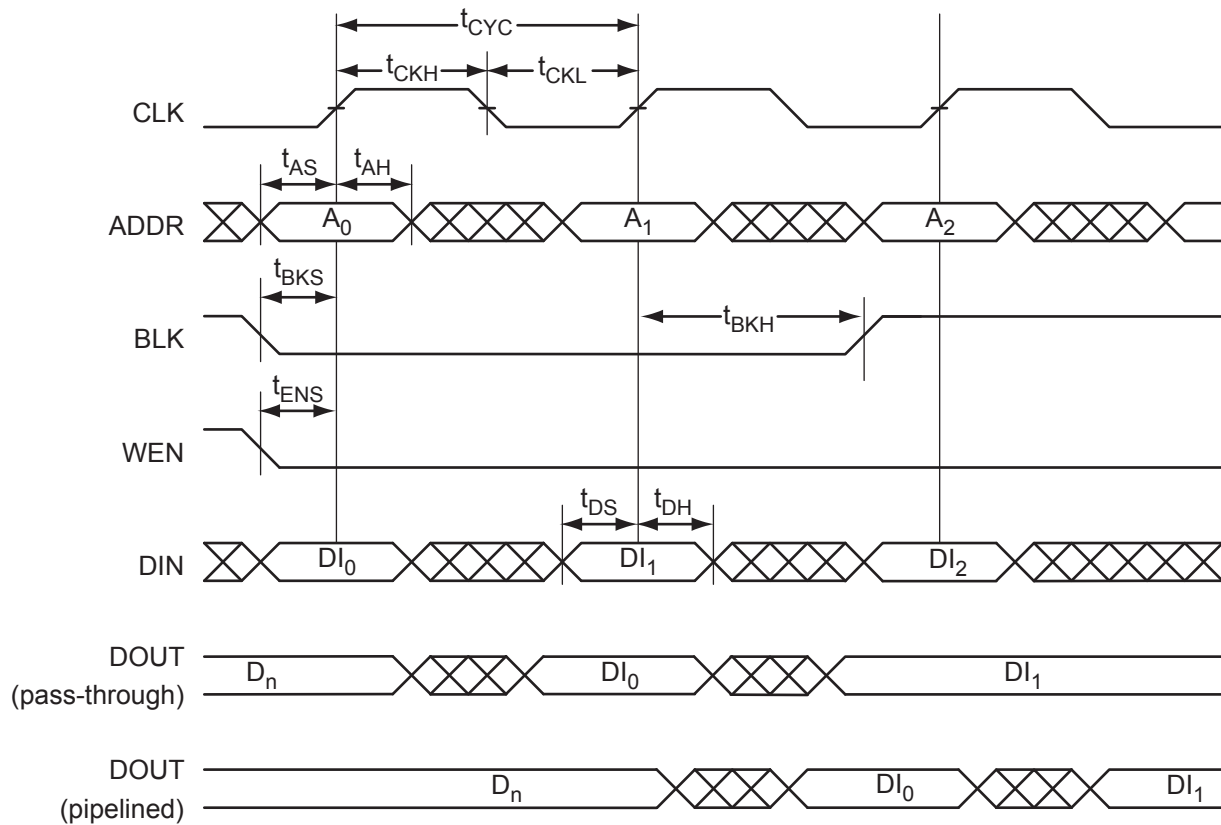

Figure 2-43 • RAM Read for Pipelined Output. Applicable to Both RAM4K9 and RAM512X18.



**Figure 2-44 • RAM Write, Output Retained. Applicable to both RAM4K9 and RAM512X18.**



**Figure 2-45 • RAM Write, Output as Write Data ( $WMODE = 1$ ). Applicable to RAM4K9 Only.**

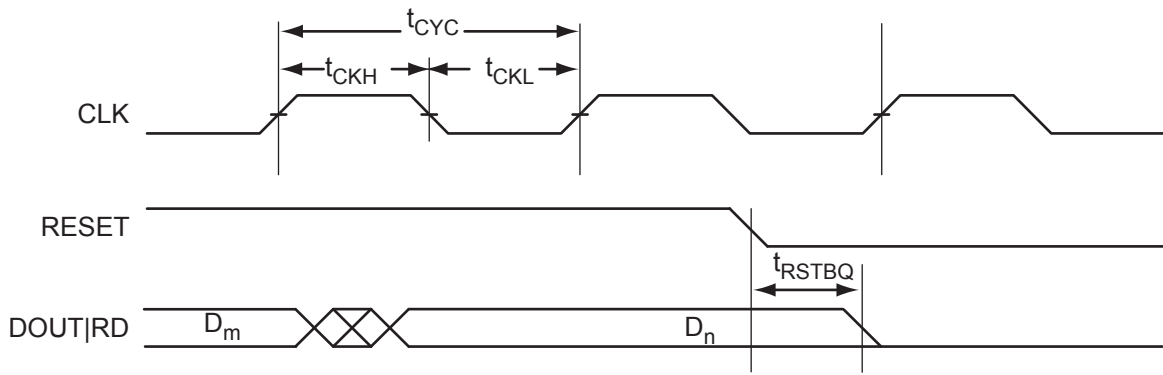

**Figure 2-46 • RAM Reset**

## Timing Characteristics

*Applies to 1.5 V DC Core Voltage*

**Table 2-145 • RAM4K9**

Commercial-Case Conditions:  $T_J = 70^\circ\text{C}$ , Worst-Case  $V_{CC} = 1.425\text{ V}$

Parameter	Description	Std.	Units
$t_{AS}$	Address Setup Time	0.83	ns
$t_{AH}$	Address Hold Time	0.16	ns
$t_{ENS}$	REN, WEN Setup Time	0.81	ns
$t_{ENH}$	REN, WEN Hold Time	0.16	ns
$t_{BKS}$	BLK Setup Time	1.65	ns
$t_{BKH}$	BLK Hold Time	0.16	ns
$t_{DS}$	Input Data (DIN) Setup Time	0.71	ns
$t_{DH}$	Input Data (DIN) Hold Time	0.36	ns
$t_{CKQ1}$	Clock HIGH to New Data Valid on DOUT (output retained, WMODE = 0)	3.53	ns
	Clock HIGH to New Data Valid on DOUT (flow-through, WMODE = 1)	3.06	ns
$t_{CKQ2}$	Clock HIGH to New Data Valid on DOUT (pipelined)	1.81	ns
$t_{C2CWWL}^1$	Address collision clk-to-clk delay for reliable write after write on same address; applicable to closing edge	0.23	ns
$t_{C2CRWH}^1$	Address collision clk-to-clk delay for reliable read access after write on same address; applicable to opening edge	0.35	ns
$t_{C2CWRH}^1$	Address collision clk-to-clk delay for reliable write access after read on same address; applicable to opening edge	0.41	ns
$t_{RSTBQ}$	RESET Low to Data Out Low on DOUT (flow-through)	2.06	ns
	RESET Low to Data Out Low on DOUT (pipelined)	2.06	ns
$t_{REMRSTB}$	RESET Removal	0.61	ns
$t_{RECRSTB}$	RESET Recovery	3.21	ns
$t_{MPWRSTB}$	RESET Minimum Pulse Width	0.68	ns
$t_{CYC}$	Clock Cycle Time	6.24	ns
$F_{MAX}$	Maximum Frequency	160	MHz

**Notes:**

1. For more information, refer to the application note [Simultaneous Read-Write Operations in Dual-Port SRAM for Flash-Based cSoCs and FPGAs](#).
2. For specific junction temperature and voltage supply levels, refer to [Table 2-6 on page 2-6](#) for derating values.

**Table 2-146 • RAM512X18**
**Commercial-Case Conditions:  $T_J = 70^\circ\text{C}$ , Worst-Case  $V_{CC} = 1.425\text{ V}$** 

Parameter	Description	Std.	Units
$t_{AS}$	Address Setup Time	0.83	ns
$t_{AH}$	Address Hold Time	0.16	ns
$t_{ENS}$	REN, WEN Setup Time	0.73	ns
$t_{ENH}$	REN, WEN Hold Time	0.08	ns
$t_{DS}$	Input Data (WD) Setup Time	0.71	ns
$t_{DH}$	Input Data (WD) Hold Time	0.36	ns
$t_{CKQ1}$	Clock HIGH to New Data Valid on RD (output retained, WMODE = 0)	4.21	ns
$t_{CKQ2}$	Clock HIGH to New Data Valid on RD (pipelined)	1.71	ns
$t_{C2CRWH}^1$	Address collision clk-to-clk delay for reliable read access after write on same address; applicable to opening edge	0.35	ns
$t_{C2CWRH}^1$	Address collision clk-to-clk delay for reliable write access after read on same address; applicable to opening edge	0.42	ns
$t_{RSTBQ}$	RESET Low to Data Out Low on RD (flow-through)	2.06	ns
	RESET Low to Data Out Low on RD (pipelined)	2.06	ns
$t_{REMRSTB}$	RESET Removal	0.61	ns
$t_{RECRSTB}$	RESET Recovery	3.21	ns
$t_{MPWRSTB}$	RESET Minimum Pulse Width	0.68	ns
$t_{CYC}$	Clock Cycle Time	6.24	ns
$F_{MAX}$	Maximum Frequency	160	MHz

**Notes:**

1. For more information, refer to the application note [Simultaneous Read-Write Operations in Dual-Port SRAM for Flash-Based cSoCs and FPGAs](#).
2. For specific junction temperature and voltage supply levels, refer to [Table 2-6 on page 2-6](#) for derating values.

**Applies to 1.2 V DC Core Voltage**

**Table 2-147 • RAM4K9**

Commercial-Case Conditions:  $T_J = 70^\circ\text{C}$ , Worst-Case  $V_{CC} = 1.14\text{ V}$

Parameter	Description	Std.	Units
$t_{AS}$	Address Setup Time	1.53	ns
$t_{AH}$	Address Hold Time	0.29	ns
$t_{ENS}$	REN, WEN Setup Time	1.50	ns
$t_{ENH}$	REN, WEN Hold Time	0.29	ns
$t_{BKS}$	BLK Setup Time	3.05	ns
$t_{BKH}$	BLK Hold Time	0.29	ns
$t_{DS}$	Input Data (DIN) Setup Time	1.33	ns
$t_{DH}$	Input Data (DIN) Hold Time	0.66	ns
$t_{CKQ1}$	Clock High to New Data Valid on DOUT (output retained, WMODE = 0)	6.61	ns
	Clock High to New Data Valid on DOUT (flow-through, WMODE = 1)	5.72	ns
$t_{CKQ2}$	Clock High to New Data Valid on DOUT (pipelined)	3.38	ns
$t_{C2CWWL}^1$	Address collision clk-to-clk delay for reliable write after write on same address; applicable to closing edge	0.30	ns
$t_{C2CRWH}^1$	Address collision clk-to-clk delay for reliable read access after write on same address; applicable to opening edge	0.89	ns
$t_{C2CWRH}^1$	Address collision clk-to-clk delay for reliable write access after read on same address; applicable to opening edge	1.01	ns
$t_{RSTBQ}$	RESET Low to Data Out Low on DOUT (pass-through)	3.86	ns
	RESET Low to Data Out Low on DOUT (pipelined)	3.86	ns
$t_{REMRSTB}$	RESET Removal	1.12	ns
$t_{RECRSTB}$	RESET Recovery	5.93	ns
$t_{MPWRSTB}$	RESET Minimum Pulse Width	1.18	ns
$t_{CYC}$	Clock Cycle Time	10.90	ns
$F_{MAX}$	Maximum Frequency	92	MHz

**Notes:**

1. For more information, refer to the application note [Simultaneous Read-Write Operations in Dual-Port SRAM for Flash-Based cSoCs and FPGAs](#).
2. For specific junction temperature and voltage supply levels, refer to [Table 2-6 on page 2-6](#) for derating values.

**Table 2-148 • RAM512X18**  
**Commercial-Case Conditions:  $T_J = 70^\circ\text{C}$ , Worst-Case  $V_{CC} = 1.14\text{ V}$**

Parameter	Description	Std.	Units
$t_{AS}$	Address Setup Time	1.53	ns
$t_{AH}$	Address Hold Time	0.29	ns
$t_{ENS}$	REN, WEN Setup Time	1.36	ns
$t_{ENH}$	REN, WEN Hold Time	0.15	ns
$t_{DS}$	Input Data (WD) Setup Time	1.33	ns
$t_{DH}$	Input Data (WD) Hold Time	0.66	ns
$t_{CKQ1}$	Clock High to New Data Valid on RD (output retained)	7.88	ns
$t_{CKQ2}$	Clock High to New Data Valid on RD (pipelined)	3.20	ns
$t_{C2CRWH}^1$	Address collision clk-to-clk delay for reliable read access after write on same address; applicable to opening edge	0.87	ns
$t_{C2CWRH}^1$	Address collision clk-to-clk delay for reliable write access after read on same address; applicable to opening edge	1.04	ns
$t_{RSTBQ}$	RESET Low to Data Out Low on RD (flow-through)	3.86	ns
	RESET Low to Data Out Low on RD (pipelined)	3.86	ns
$t_{REMRSTB}$	RESET Removal	1.12	ns
$t_{RECRSTB}$	RESET Recovery	5.93	ns
$t_{MPWRSTB}$	RESET Minimum Pulse Width	1.18	ns
$t_{CYC}$	Clock Cycle Time	10.90	ns
$F_{MAX}$	Maximum Frequency	92	MHz

**Notes:**

1. For more information, refer to the application note [Simultaneous Read-Write Operations in Dual-Port SRAM for Flash-Based cSoCs and FPGAs](#).
2. For specific junction temperature and voltage supply levels, refer to [Table 2-6 on page 2-6](#) for derating values.

## FIFO

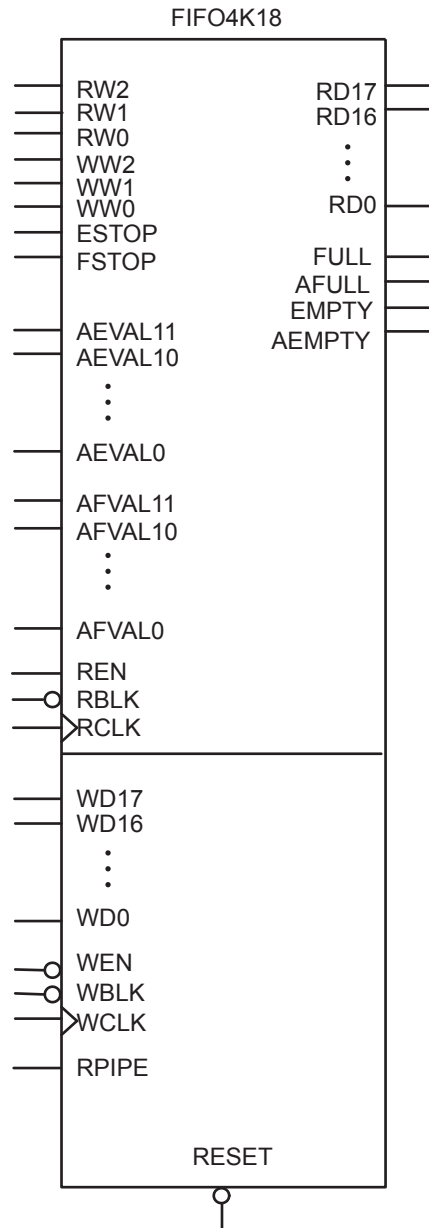

Figure 2-47 • FIFO Model

### Timing Waveforms

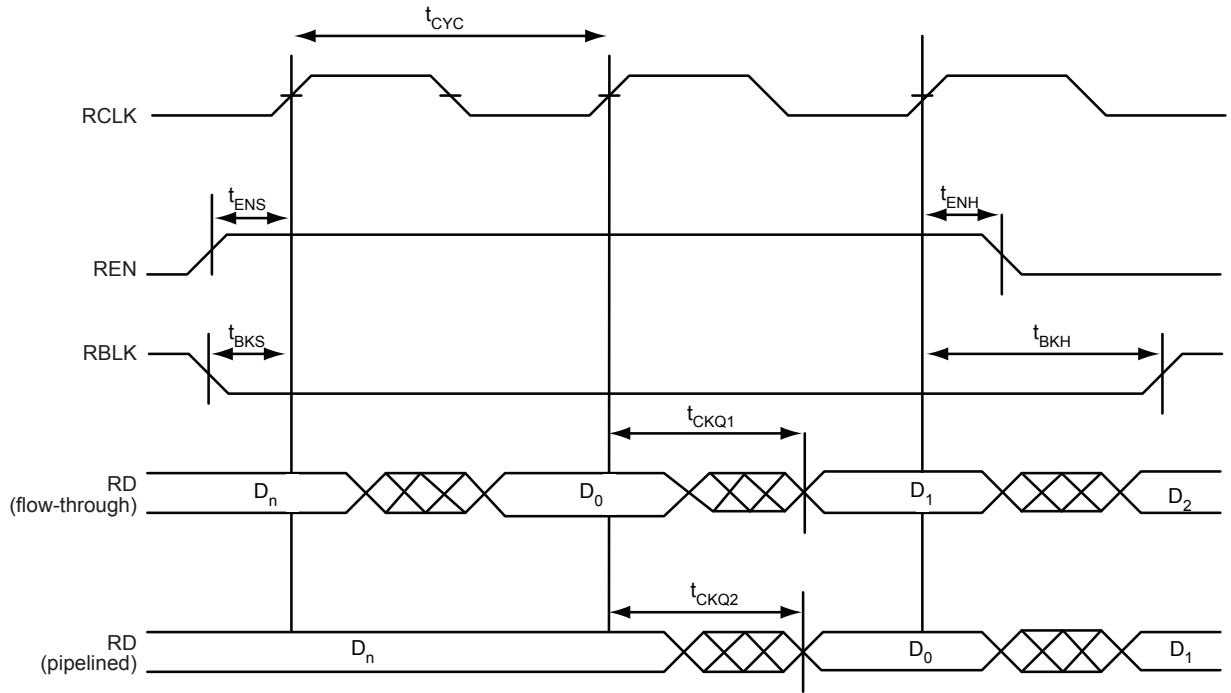

Figure 2-48 • FIFO Read

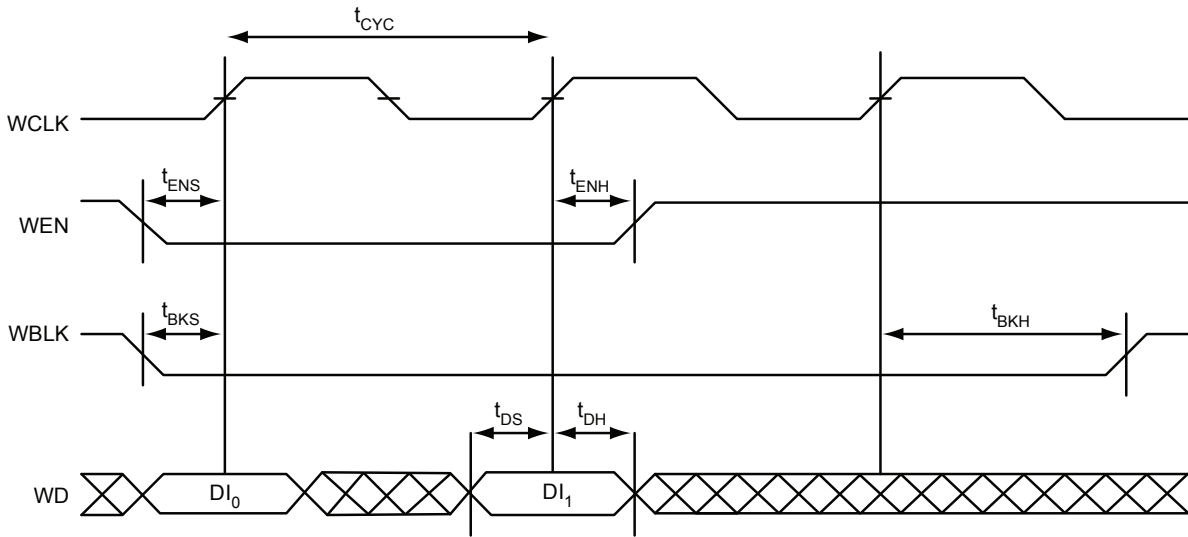
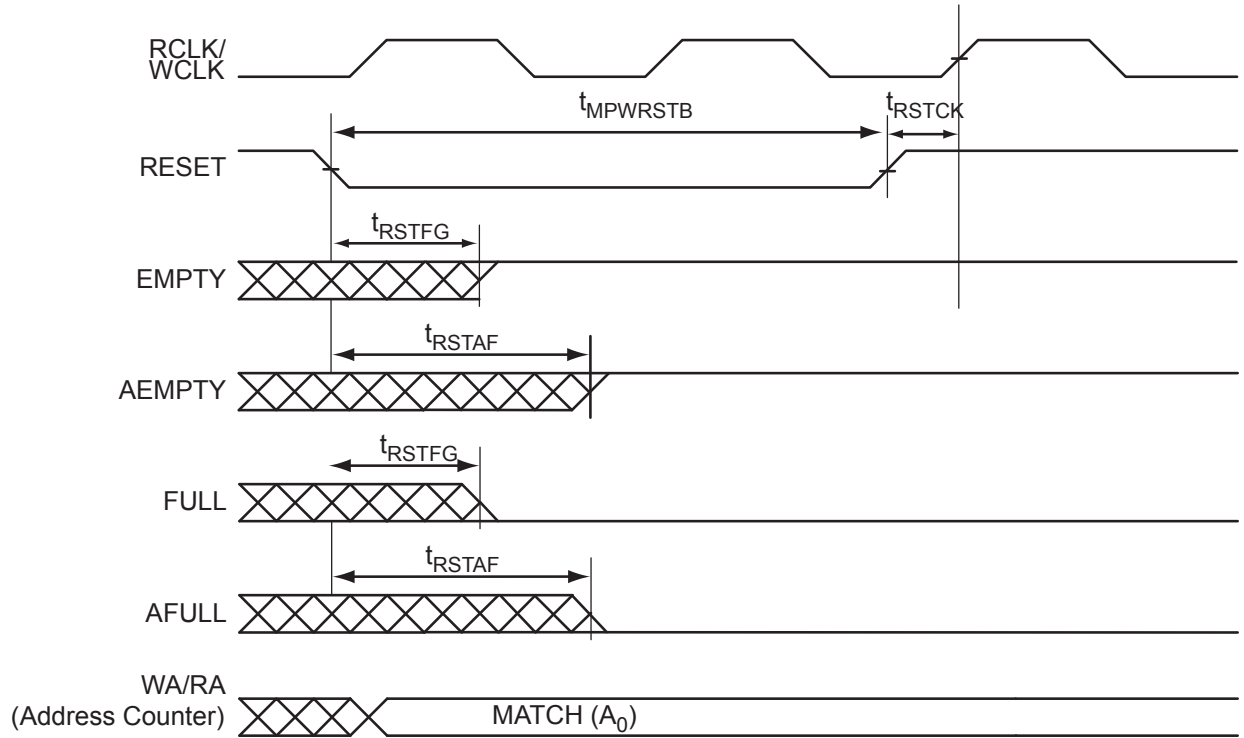
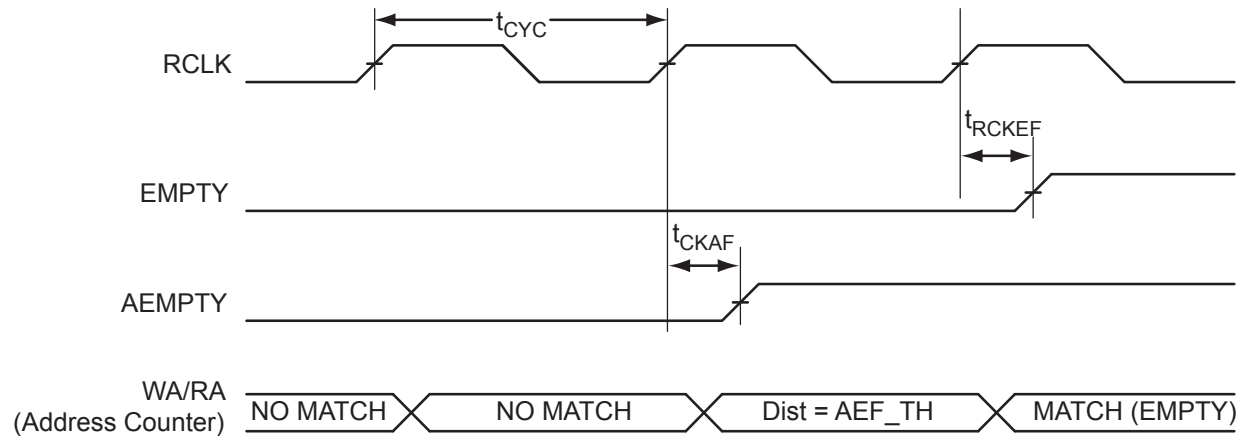

Figure 2-49 • FIFO Write



**Figure 2-50 • FIFO Reset**



**Figure 2-51 • FIFO EMPTY Flag and AEMPTY Flag Assertion**

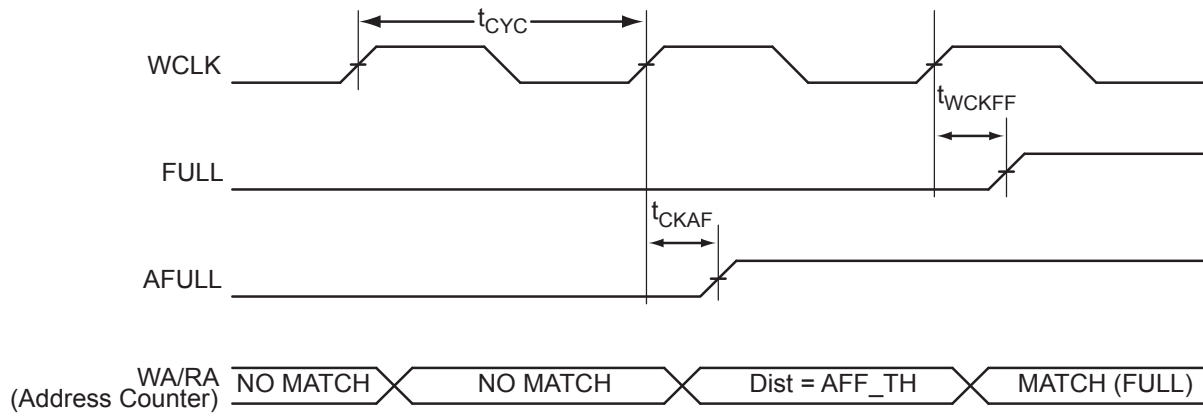

**Figure 2-52 • FIFO FULL Flag and AFULL Flag Assertion**

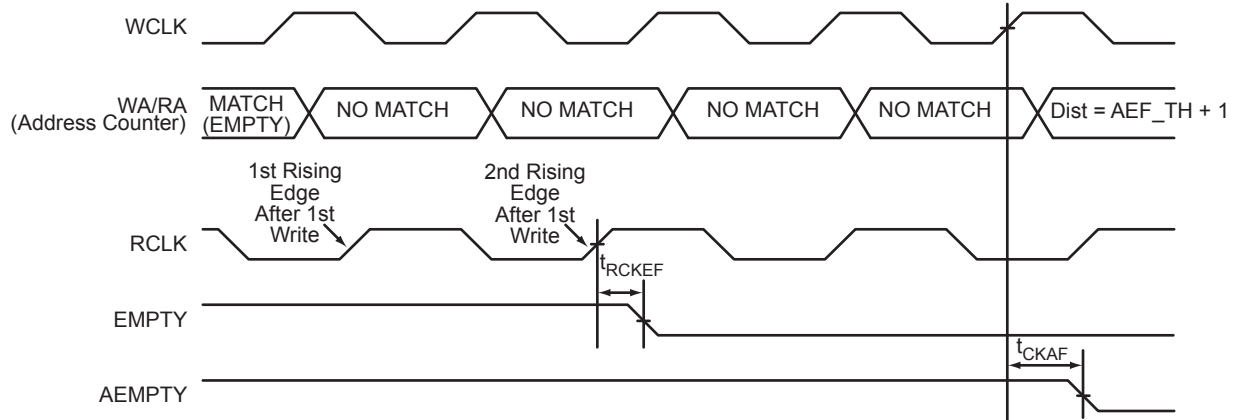

**Figure 2-53 • FIFO EMPTY Flag and AEMPTY Flag Deassertion**

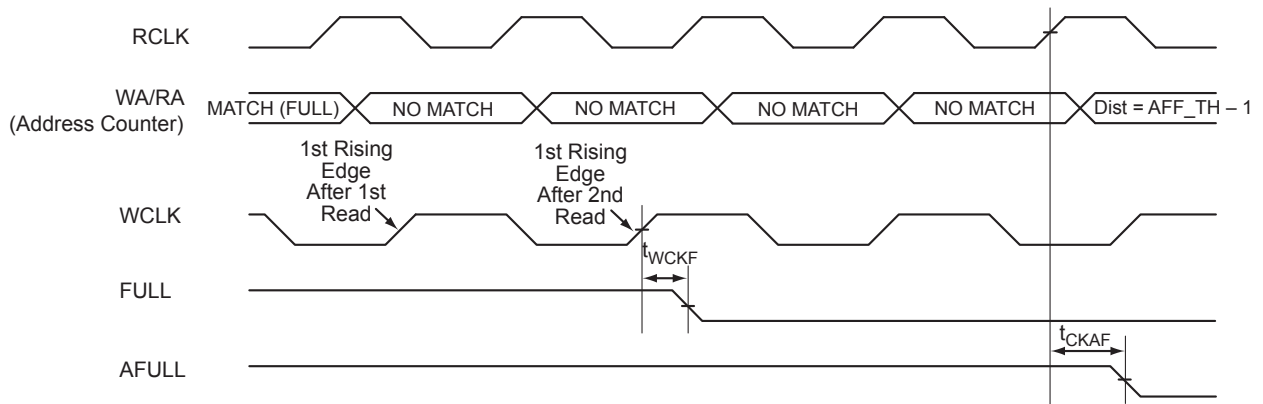

**Figure 2-54 • FIFO FULL Flag and AFULL Flag Deassertion**

## Timing Characteristics

*Applies to 1.5 V DC Core Voltage*

**Table 2-149 • FIFO**

Commercial-Case Conditions:  $T_J = 70^\circ\text{C}$ ,  $V_{CC} = 1.425\text{ V}$

Parameter	Description	Std.	Units
$t_{ENS}$	REN, WEN Setup Time	1.99	ns
$t_{ENH}$	REN, WEN Hold Time	0.16	ns
$t_{BKS}$	BLK Setup Time	0.30	ns
$t_{BKH}$	BLK Hold Time	0.00	ns
$t_{DS}$	Input Data (WD) Setup Time	0.76	ns
$t_{DH}$	Input Data (WD) Hold Time	0.25	ns
$t_{CKQ1}$	Clock HIGH to New Data Valid on RD (pass-through)	3.33	ns
$t_{CKQ2}$	Clock HIGH to New Data Valid on RD (pipelined)	1.80	ns
$t_{RCKEF}$	RCLK HIGH to Empty Flag Valid	3.53	ns
$t_{WCKFF}$	WCLK HIGH to Full Flag Valid	3.35	ns
$t_{CKAF}$	Clock HIGH to Almost Empty/Full Flag Valid	12.85	ns
$t_{RSTFG}$	RESET LOW to Empty/Full Flag Valid	3.48	ns
$t_{RSTAF}$	RESET LOW to Almost Empty/Full Flag Valid	12.72	ns
$t_{RSTBQ}$	RESET LOW to Data Out LOW on RD (pass-through)	2.02	ns
	RESET LOW to Data Out LOW on RD (pipelined)	2.02	ns
$t_{REMRSTB}$	RESET Removal	0.61	ns
$t_{RECRSTB}$	RESET Recovery	3.21	ns
$t_{MPWRSTB}$	RESET Minimum Pulse Width	0.68	ns
$t_{CYC}$	Clock Cycle Time	6.24	ns
$F_{MAX}$	Maximum Frequency	160	MHz

*Note:* For specific junction temperature and voltage supply levels, refer to [Table 2-6 on page 2-6](#) for derating values.

*Applies to 1.2 V DC Core Voltage*

**Table 2-150 • FIFO**  
**Commercial-Case Conditions:  $T_J = 70^\circ\text{C}$ ,  $V_{CC} = 1.14\text{ V}$**

Parameter	Description	Std.	Units
$t_{ENS}$	REN, WEN Setup Time	4.13	ns
$t_{ENH}$	REN, WEN Hold Time	0.31	ns
$t_{BKS}$	BLK Setup Time	0.47	ns
$t_{BKH}$	BLK Hold Time	0.00	ns
$t_{DS}$	Input Data (WD) Setup Time	1.56	ns
$t_{DH}$	Input Data (WD) Hold Time	0.49	ns
$t_{CKQ1}$	Clock HIGH to New Data Valid on RD (pass-through)	6.80	ns
$t_{CKQ2}$	Clock HIGH to New Data Valid on RD (pipelined)	3.62	ns
$t_{RCKEF}$	RCLK HIGH to Empty Flag Valid	7.23	ns
$t_{WCKFF}$	WCLK HIGH to Full Flag Valid	6.85	ns
$t_{CKAF}$	Clock HIGH to Almost Empty/Full Flag Valid	26.61	ns
$t_{RSTFG}$	RESET LOW to Empty/Full Flag Valid	7.12	ns
$t_{RSTAF}$	RESET LOW to Almost Empty/Full Flag Valid	26.33	ns
$t_{RSTBQ}$	RESET LOW to Data Out LOW on RD (pass-through)	4.09	ns
	RESET LOW to Data Out LOW on RD (pipelined)	4.09	ns
$t_{REMRSTB}$	RESET Removal	1.23	ns
$t_{RECRSTB}$	RESET Recovery	6.58	ns
$t_{MPWRSTB}$	RESET Minimum Pulse Width	1.18	ns
$t_{CYC}$	Clock Cycle Time	10.90	ns
$F_{MAX}$	Maximum Frequency	92	MHz

*Note:* For specific junction temperature and voltage supply levels, refer to [Table 2-7 on page 2-6](#) for derating values.

# Embedded FlashROM Characteristics

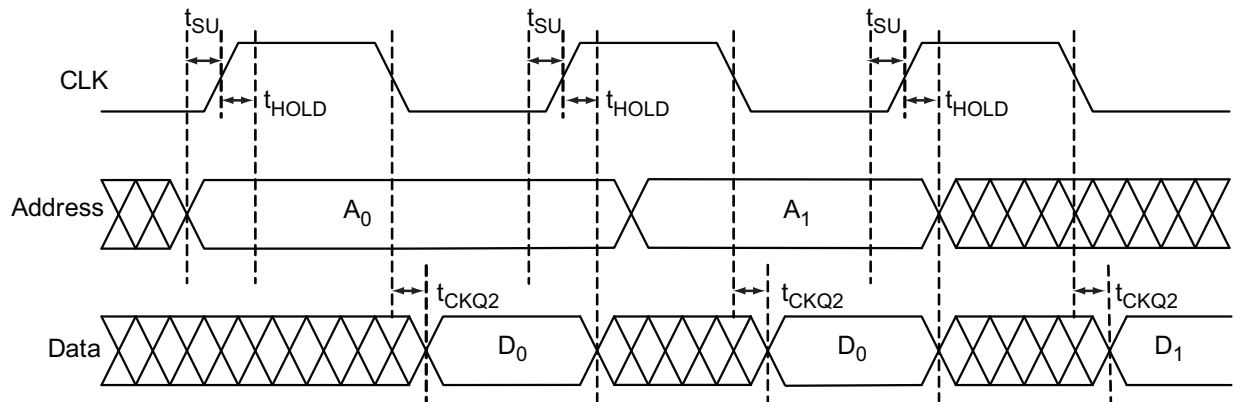

Figure 2-55 • Timing Diagram

## Timing Characteristics

*Applies to 1.5 V DC Core Voltage*

Table 2-151 • Embedded FlashROM Access Time

Commercial-Case Conditions: T<sub>J</sub> = 70°C, VCC = 1.425 V

Parameter	Description	Std.	Units
t <sub>SU</sub>	Address Setup Time	0.58	ns
t <sub>HOLD</sub>	Address Hold Time	0.00	ns
t <sub>CK2Q</sub>	Clock-to-Out	34.14	ns
F <sub>MAX</sub>	Maximum Clock Frequency	15	MHz

*Applies to 1.2 V DC Core Voltage*

Table 2-152 • Embedded FlashROM Access Time

Commercial-Case Conditions: T<sub>J</sub> = 70°C, VCC = 1.14 V

Parameter	Description	Std.	Units
t <sub>SU</sub>	Address Setup Time	0.59	ns
t <sub>HOLD</sub>	Address Hold Time	0.00	ns
t <sub>CK2Q</sub>	Clock-to-Out	52.90	ns
F <sub>MAX</sub>	Maximum Clock Frequency	10	MHz

## JTAG 1532 Characteristics

JTAG timing delays do not include JTAG I/Os. To obtain complete JTAG timing, add I/O buffer delays to the corresponding standard selected; refer to the I/O timing characteristics in the "User I/O Characteristics" section on page 2-16 for more details.

### Timing Characteristics

*Applies to 1.2 V DC Core Voltage*

**Table 2-153 • JTAG 1532**  
 Commercial-Case Conditions:  $T_J = 70^\circ\text{C}$ ,  $V_{CC} = 1.14\text{ V}$

Parameter	Description	Std.	Units
$t_{DISU}$	Test Data Input Setup Time	1.50	ns
$t_{DIHD}$	Test Data Input Hold Time	3.00	ns
$t_{TMSSU}$	Test Mode Select Setup Time	1.50	ns
$t_{TMDHD}$	Test Mode Select Hold Time	3.00	ns
$t_{TCK2Q}$	Clock to Q (data out)	11.00	ns
$t_{RSTB2Q}$	Reset to Q (data out)	30.00	ns
$F_{TCKMAX}$	TCK Maximum Frequency	9.00	MHz
$t_{TRSTREM}$	ResetB Removal Time	1.18	ns
$t_{TRSTREC}$	ResetB Recovery Time	0.00	ns
$t_{TRSTMPW}$	ResetB Minimum Pulse	TBD	ns

*Note:* For specific junction temperature and voltage supply levels, refer to Table 2-7 on page 2-6 for derating values.

*Applies to 1.5 V DC Core Voltage*

**Table 2-154 • JTAG 1532**  
 Commercial-Case Conditions:  $T_J = 70^\circ\text{C}$ ,  $V_{CC} = 1.425\text{ V}$

Parameter	Description	Std.	Units
$t_{DISU}$	Test Data Input Setup Time	1.00	ns
$t_{DIHD}$	Test Data Input Hold Time	2.00	ns
$t_{TMSSU}$	Test Mode Select Setup Time	1.00	ns
$t_{TMDHD}$	Test Mode Select Hold Time	2.00	ns
$t_{TCK2Q}$	Clock to Q (data out)	8.00	ns
$t_{RSTB2Q}$	Reset to Q (data out)	25.00	ns
$F_{TCKMAX}$	TCK Maximum Frequency	15.00	MHz
$t_{TRSTREM}$	ResetB Removal Time	0.58	ns
$t_{TRSTREC}$	ResetB Recovery Time	0.00	ns
$t_{TRSTMPW}$	ResetB Minimum Pulse	TBD	ns

*Note:* For specific junction temperature and voltage supply levels, refer to Table 2-6 on page 2-6 for derating values.



---

## 3 – Pin Descriptions and Packaging

---

### Supply Pins

**GND****Ground**

Ground supply voltage to the core, I/O outputs, and I/O logic.

**GNDQ****Ground (quiet)**

Quiet ground supply voltage to input buffers of I/O banks. Within the package, the GNDQ plane is decoupled from the simultaneous switching noise originated from the output buffer ground domain. This minimizes the noise transfer within the package and improves input signal integrity. GNDQ must always be connected to GND on the board.

**VCC****Core Supply Voltage**

Supply voltage to the FPGA core, nominally 1.5 V for IGLOOe V5 devices, and 1.2 V or 1.5 V for IGLOOe V2 devices. VCC is required for powering the JTAG state machine in addition to VJTAG. Even when a device is in bypass mode in a JTAG chain of interconnected devices, both VCC and VJTAG must remain powered to allow JTAG signals to pass through the device.

For IGLOOe V2 devices, VCC can be switched dynamically from 1.2 V to 1.5 V or vice versa. This allows in-system programming (ISP) when VCC is at 1.5 V and the benefit of low power operation when VCC is at 1.2 V.

**VCCIBx****I/O Supply Voltage**

Supply voltage to the bank's I/O output buffers and I/O logic. Bx is the I/O bank number. There are up to eight I/O banks on IGLOOe devices plus a dedicated VJTAG bank. Each bank can have a separate VCCI connection. All I/Os in a bank will run off the same VCCIBx supply. VCCI can be 1.2 V, 1.5 V, 1.8 V, 2.5 V, or 3.3 V, nominal voltage. Unused I/O banks should have their corresponding VCCI pins tied to GND.

**VMVx****I/O Supply Voltage (quiet)**

Quiet supply voltage to the input buffers of each I/O bank. x is the bank number. Within the package, the VMV plane biases the input stage of the I/Os in the I/O banks. This minimizes the noise transfer within the package and improves input signal integrity. Each bank must have at least one VMV connection, and no VMV should be left unconnected. All I/Os in a bank run off the same VMVx supply. VMV is used to provide a quiet supply voltage to the input buffers of each I/O bank. VMVx can be 1.2 V, 1.5 V, 1.8 V, 2.5 V, or 3.3 V, nominal voltage. Unused I/O banks should have their corresponding VMV pins tied to GND. VMV and VCCI should be at the same voltage within a given I/O bank. Used VMV pins must be connected to the corresponding VCCI pins of the same bank (i.e., VMV0 to VCCIB0, VMV1 to VCCIB1, etc.).

**VCCPLA/B/C/D/E/F****PLL Supply Voltage**

Supply voltage to analog PLL, nominally 1.5 V or 1.2 V, depending on the device.

- 1.5 V for IGLOOe devices
- 1.2 V or 1.5 V for IGLOOe V2 devices

When the PLLs are not used, the place-and-route tool automatically disables the unused PLLs to lower power consumption. The user should tie unused VCCPLx and VCOMPLx pins to ground. Microsemi recommends tying VCCPLx to VCC and using proper filtering circuits to decouple VCC noise from the PLLs. Refer to the PLL Power Supply Decoupling section in the "Clock Conditioning Circuits in Low Power Flash FPGAs and Mixed Signal FPGAs" chapter in the *IGLOOe FPGA Fabric User's Guide* for a complete board solution for the PLL analog power supply and ground.

There are six VCCPLX pins on IGLOOe devices.

**VCOMPLA/B/C/D/E/F      PLL Ground**

Ground to analog PLL power supplies. When the PLLs are not used, the place-and-route tool automatically disables the unused PLLs to lower power consumption. The user should tie unused VCCPLx and VCOMPLx pins to ground.

There are six VCOMPL pins (PLL ground) on IGLOOe devices.

**VJTAG      JTAG Supply Voltage**

Low power flash devices have a separate bank for the dedicated JTAG pins. The JTAG pins can be run at any voltage from 1.5 V to 3.3 V (nominal). Isolating the JTAG power supply in a separate I/O bank gives greater flexibility in supply selection and simplifies power supply and PCB design. If the JTAG interface is neither used nor planned for use, the VJTAG pin together with the TRST pin could be tied to GND. It should be noted that VCC is required to be powered for JTAG operation; VJTAG alone is insufficient. If a device is in a JTAG chain of interconnected boards, the board containing the device can be powered down, provided both VJTAG and VCC to the part remain powered; otherwise, JTAG signals will not be able to transition the device, even in bypass mode.

Microsemi recommends that VPUMP and VJTAG power supplies be kept separate with independent filtering capacitors rather than supplying them from a common rail.

**VPUMP      Programming Supply Voltage**

IGLOOe devices support single-voltage ISP of the configuration flash and FlashROM. For programming, VPUMP should be 3.3 V nominal. During normal device operation, VPUMP can be left floating or can be tied (pulled up) to any voltage between 0 V and the VPUMP maximum. Programming power supply voltage (VPUMP) range is listed in the datasheet.

When the VPUMP pin is tied to ground, it will shut off the charge pump circuitry, resulting in no sources of oscillation from the charge pump circuitry.

For proper programming, 0.01  $\mu$ F and 0.33  $\mu$ F capacitors (both rated at 16 V) are to be connected in parallel across VPUMP and GND, and positioned as close to the FPGA pins as possible.

Microsemi recommends that VPUMP and VJTAG power supplies be kept separate with independent filtering capacitors rather than supplying them from a common rail.

## User-Defined Supply Pins

**VREF      I/O Voltage Reference**

Reference voltage for I/O minibanks. VREF pins are configured by the user from regular I/Os, and any I/O in a bank, except JTAG I/Os, can be designated the voltage reference I/O. Only certain I/O standards require a voltage reference—HSTL (I) and (II), SSTL2 (I) and (II), SSTL3 (I) and (II), and GTL/GTL+. One VREF pin can support the number of I/Os available in its minibank.

## User Pins

### **I/O** **User Input/Output**

The I/O pin functions as an input, output, tristate, or bidirectional buffer. Input and output signal levels are compatible with the I/O standard selected.

During programming, I/Os become tristated and weakly pulled up to VCCI. With VCCI, VMV, and VCC supplies continuously powered up, when the device transitions from programming to operating mode, the I/Os are instantly configured to the desired user configuration.

Unused I/Os are configured as follows:

- Output buffer is disabled (with tristate value of high impedance)
- Input buffer is disabled (with tristate value of high impedance)
- Weak pull-up is programmed

### **GL** **Globals**

GL I/Os have access to certain clock conditioning circuitry (and the PLL) and/or have direct access to the global network (spines). Additionally, the global I/Os can be used as regular I/Os, since they have identical capabilities. Unused GL pins are configured as inputs with pull-up resistors.

See more detailed descriptions of global I/O connectivity in the "Clock Conditioning Circuits in Low Power Flash Devices and Mixed Signal FPGAs" chapter of the *IGLOOe FPGA Fabric User's Guide*. All inputs labeled GC/GF are direct inputs into the quadrant clocks. For example, if GAA0 is used for an input, GAA1 and GAA2 are no longer available for input to the quadrant globals. All inputs labeled GC/GF are direct inputs into the chip-level globals, and the rest are connected to the quadrant globals. The inputs to the global network are multiplexed, and only one input can be used as a global input.

Refer to the I/O Structure section of the *IGLOOe FPGA Fabric User's Guide* for an explanation of the naming of global pins.

### **FF** **Flash\*Freeze Mode Activation Pin**

Flash\*Freeze mode is available on IGLOOe devices. The FF pin is a dedicated input pin used to enter and exit Flash\*Freeze mode. The FF pin is active low, has the same characteristics as a single-ended I/O, and must meet the maximum rise and fall times. When Flash\*Freeze mode is not used in the design, the FF pin is available as a regular I/O. The FF pin can be configured as a Schmitt trigger input.

When Flash\*Freeze mode is used, the FF pin must not be left floating to avoid accidentally entering Flash\*Freeze mode. While in Flash\*Freeze mode, the Flash\*Freeze pin should be constantly asserted.

The Flash\*Freeze pin can be used with any single-ended I/O standard supported by the I/O bank in which the pin is located, and input signal levels compatible with the I/O standard selected. The FF pin should be treated as a sensitive asynchronous signal. When defining pin placement and board layout, simultaneously switching outputs (SSOs) and their effects on sensitive asynchronous pins must be considered.

Unused FF or I/O pins are tristated with weak pull-up. This default configuration applies to both Flash\*Freeze mode and normal operation mode. No user intervention is required.

Table 3-1 shows the Flash\*Freeze pin location on the available packages. The Flash\*Freeze pin location is independent of device (except for a PQ208 package), allowing migration to larger or smaller IGLOO devices while maintaining the same pin location on the board. Refer to the "Flash\*Freeze Technology and Low Power Modes" chapter of the *IGLOOe FPGA Fabric User's Guide* for more information on I/O states during Flash\*Freeze mode.

**Table 3-1 • Flash\*Freeze Pin Locations for IGLOOe Devices**

Package	Flash*Freeze Pin
FG256	T3
FG484	W6
FG896	AH4

## JTAG Pins

Low power flash devices have a separate bank for the dedicated JTAG pins. The JTAG pins can be run at any voltage from 1.5 V to 3.3 V (nominal). VCC must also be powered for the JTAG state machine to operate, even if the device is in bypass mode; VJTAG alone is insufficient. Both VJTAG and VCC to the part must be supplied to allow JTAG signals to transition the device. Isolating the JTAG power supply in a separate I/O bank gives greater flexibility in supply selection and simplifies power supply and PCB design. If the JTAG interface is neither used nor planned for use, the VJTAG pin together with the TRST pin could be tied to GND.

### TCK Test Clock

Test clock input for JTAG boundary scan, ISP, and UJTAG. The TCK pin does not have an internal pull-up/down resistor. If JTAG is not used, Microsemi recommends tying off TCK to GND through a resistor placed close to the FPGA pin. This prevents JTAG operation in case TMS enters an undesired state.

Note that to operate at all VJTAG voltages, 500  $\Omega$  to 1 k $\Omega$  will satisfy the requirements. Refer to [Table 3-2](#) for more information.

**Table 3-2 • Recommended Tie-Off Values for the TCK and TRST Pins**

VJTAG	Tie-Off Resistance <sup>1,2</sup>
VJTAG at 3.3 V	200 $\Omega$ to 1 k $\Omega$
VJTAG at 2.5 V	200 $\Omega$ to 1 k $\Omega$
VJTAG at 1.8 V	500 $\Omega$ to 1 k $\Omega$
VJTAG at 1.5 V	500 $\Omega$ to 1 k $\Omega$

*Notes:*

1. The TCK pin can be pulled-up or pulled-down.
2. The TRST pin is pulled-down.
3. Equivalent parallel resistance if more than one device is on the JTAG chain

**Table 3-3 • TRST and TCK Pull-Down Recommendations**

VJTAG	Tie-Off Resistance*
VJTAG at 3.3 V	200 $\Omega$ to 1 k $\Omega$
VJTAG at 2.5 V	200 $\Omega$ to 1 k $\Omega$
VJTAG at 1.8 V	500 $\Omega$ to 1 k $\Omega$
VJTAG at 1.5 V	500 $\Omega$ to 1 k $\Omega$

*Note:* Equivalent parallel resistance if more than one device is on the JTAG chain

**TDI Test Data Input**

Serial input for JTAG boundary scan, ISP, and UJTAG usage. There is an internal weak pull-up resistor on the TDI pin.

**TDO Test Data Output**

Serial output for JTAG boundary scan, ISP, and UJTAG usage.

**TMS Test Mode Select**

The TMS pin controls the use of the IEEE 1532 boundary scan pins (TCK, TDI, TDO, TRST). There is an internal weak pull-up resistor on the TMS pin.

**TRST Boundary Scan Reset Pin**

The TRST pin functions as an active-low input to asynchronously initialize (or reset) the boundary scan circuitry. There is an internal weak pull-up resistor on the TRST pin. If JTAG is not used, an external pull-down resistor could be included to ensure the test access port (TAP) is held in reset mode. The resistor values must be chosen from [Table 3-2](#) and must satisfy the parallel resistance value requirement. The values in [Table 3-2](#) correspond to the resistor recommended when a single device is used, and the equivalent parallel resistor when multiple devices are connected via a JTAG chain.

In critical applications, an upset in the JTAG circuit could allow entrance to an undesired JTAG state. In such cases, Microsemi recommends tying off TRST to GND through a resistor placed close to the FPGA pin.

Note that to operate at all VJTAG voltages, 500  $\Omega$  to 1 k $\Omega$  will satisfy the requirements.

## Special Function Pins

**NC No Connect**

This pin is not connected to circuitry within the device. These pins can be driven to any voltage or can be left floating with no effect on the operation of the device.

**DC Do Not Connect**

This pin should not be connected to any signals on the PCB. These pins should be left unconnected.

## Packaging

Semiconductor technology is constantly shrinking in size while growing in capability and functional integration. To enable next-generation silicon technologies, semiconductor packages have also evolved to provide improved performance and flexibility.

Microsemi consistently delivers packages that provide the necessary mechanical and environmental protection to ensure consistent reliability and performance. Microsemi IC packaging technology efficiently supports high-density FPGAs with large-pin-count Ball Grid Arrays (BGAs), but is also flexible enough to accommodate stringent form factor requirements for Chip Scale Packaging (CSP). In addition, Microsemi offers a variety of packages designed to meet your most demanding application and economic requirements for today's embedded and mobile systems.

## Related Documents

### User's Guides

*IGLOOe FPGA Fabric User's Guide*

[http://www.microsemi.com/soc/documents/IGLOOe\\_UG.pdf](http://www.microsemi.com/soc/documents/IGLOOe_UG.pdf)

### Packaging Documents

The following documents provide packaging information and device selection for low power flash devices.

#### ***Product Catalog***

[http://www.microsemi.com/soc/documents/ProdCat\\_PIB.pdf](http://www.microsemi.com/soc/documents/ProdCat_PIB.pdf)

Lists devices currently recommended for new designs and the packages available for each member of the family. Use this document or the datasheet tables to determine the best package for your design, and which package drawing to use.

#### ***Package Mechanical Drawings***

<http://www.microsemi.com/soc/documents/PckgMechDrwngs.pdf>

This document contains the package mechanical drawings for all packages currently or previously supplied by Microsemi. Use the bookmarks to navigate to the package mechanical drawings.

Additional packaging materials: <http://www.microsemi.com/soc/products/solutions/package/docs.aspx>.

---

## 4 – Package Pin Assignments

---

### FG256

---

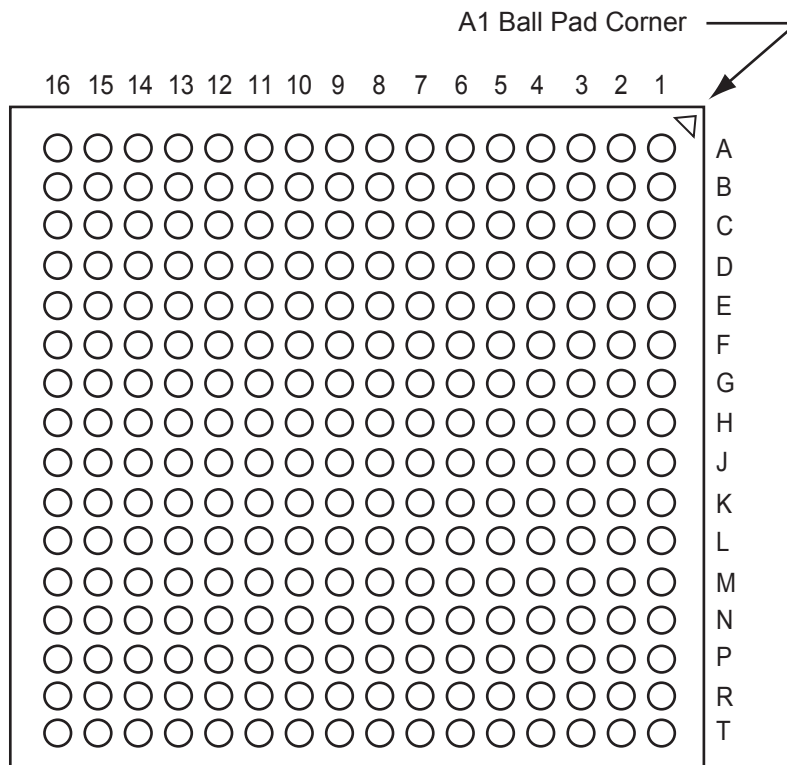

*Note:* This is the bottom view of the package.

---

### **Note**

For Package Manufacturing and Environmental information, visit the Resource Center at <http://www.microsemi.com/soc/products/solutions/package/docs.aspx>.

FG256		FG256		FG256	
Pin Number	AGLE600 Function	Pin Number	AGLE600 Function	Pin Number	AGLE600 Function
A1	GND	C5	GAC0/IO02NDB0V0	E9	IO21NDB1V0
A2	GAA0/IO00NDB0V0	C6	GAC1/IO02PDB0V0	E10	VCCIB1
A3	GAA1/IO00PDB0V0	C7	IO15NDB0V2	E11	VCCIB1
A4	GAB0/IO01NDB0V0	C8	IO15PDB0V2	E12	VMV1
A5	IO05PDB0V0	C9	IO20PDB1V0	E13	GBC2/IO38PDB2V0
A6	IO10PDB0V1	C10	IO25NDB1V0	E14	IO37NDB2V0
A7	IO12PDB0V2	C11	IO27PDB1V0	E15	IO41NDB2V0
A8	IO16NDB0V2	C12	GBC0/IO33NDB1V1	E16	IO41PDB2V0
A9	IO23NDB1V0	C13	VCCPLB	F1	IO124PDB7V0
A10	IO23PDB1V0	C14	VMV2	F2	IO125PDB7V0
A11	IO28NDB1V1	C15	IO36NDB2V0	F3	IO126PDB7V0
A12	IO28PDB1V1	C16	IO42PDB2V0	F4	IO130NDB7V1
A13	GBB1/IO34PDB1V1	D1	IO128PDB7V1	F5	VCCIB7
A14	GBA0/IO35NDB1V1	D2	IO129PDB7V1	F6	GND
A15	GBA1/IO35PDB1V1	D3	GAC2/IO132PDB7V1	F7	VCC
A16	GND	D4	VCOMPLA	F8	VCC
B1	GAB2/IO133PDB7V1	D5	GNDQ	F9	VCC
B2	GAA2/IO134PDB7V1	D6	IO09NDB0V1	F10	VCC
B3	GNDQ	D7	IO09PDB0V1	F11	GND
B4	GAB1/IO01PDB0V0	D8	IO13PDB0V2	F12	VCCIB2
B5	IO05NDB0V0	D9	IO21PDB1V0	F13	IO38NDB2V0
B6	IO10NDB0V1	D10	IO25PDB1V0	F14	IO40NDB2V0
B7	IO12NDB0V2	D11	IO27NDB1V0	F15	IO40PDB2V0
B8	IO16PDB0V2	D12	GNDQ	F16	IO45PSB2V1
B9	IO20NDB1V0	D13	VCOMPLB	G1	IO124NDB7V0
B10	IO24NDB1V0	D14	GBB2/IO37PDB2V0	G2	IO125NDB7V0
B11	IO24PDB1V0	D15	IO39PDB2V0	G3	IO126NDB7V0
B12	GBC1/IO33PDB1V1	D16	IO39NDB2V0	G4	GFC1/IO120PPB7V0
B13	GBB0/IO34NDB1V1	E1	IO128NDB7V1	G5	VCCIB7
B14	GNDQ	E2	IO129NDB7V1	G6	VCC
B15	GBA2/IO36PDB2V0	E3	IO132NDB7V1	G7	GND
B16	IO42NDB2V0	E4	IO130PDB7V1	G8	GND
C1	IO133NDB7V1	E5	VMV0	G9	GND
C2	IO134NDB7V1	E6	VCCIB0	G10	GND
C3	VMV7	E7	VCCIB0	G11	VCC
C4	VCCPLA	E8	IO13NDB0V2	G12	VCCIB2

FG256		FG256		FG256	
Pin Number	AGLE600 Function	Pin Number	AGLE600 Function	Pin Number	AGLE600 Function
G13	GCC1/IO50PPB2V1	K1	GFC2/IO115PSB6V1	M5	VMV5
G14	IO44NDB2V1	K2	IO113PPB6V1	M6	VCCIB5
G15	IO44PDB2V1	K3	IO112PDB6V1	M7	VCCIB5
G16	IO49NSB2V1	K4	IO112NDB6V1	M8	IO84NDB5V0
H1	GFB0/IO119NPB7V0	K5	VCCIB6	M9	IO84PDB5V0
H2	GFA0/IO118NDB6V1	K6	VCC	M10	VCCIB4
H3	GFB1/IO119PPB7V0	K7	GND	M11	VCCIB4
H4	VCOMPLF	K8	GND	M12	VMV3
H5	GFC0/IO120NPB7V0	K9	GND	M13	VCCPLD
H6	VCC	K10	GND	M14	GDB1/IO66PPB3V1
H7	GND	K11	VCC	M15	GDC1/IO65PDB3V1
H8	GND	K12	VCCIB3	M16	IO61NDB3V1
H9	GND	K13	IO54NPB3V0	N1	IO105PDB6V0
H10	GND	K14	IO57NPB3V0	N2	IO105NDB6V0
H11	VCC	K15	IO55NPB3V0	N3	GEC1/IO104PPB6V0
H12	GCC0/IO50NPB2V1	K16	IO57PPB3V0	N4	VCOMPLE
H13	GCB1/IO51PPB2V1	L1	IO113NPB6V1	N5	GNDQ
H14	GCA0/IO52NPB3V0	L2	IO109PPB6V0	N6	GEA2/IO101PPB5V2
H15	VCOMPLC	L3	IO108PDB6V0	N7	IO92NDB5V1
H16	GCB0/IO51NPB2V1	L4	IO108NDB6V0	N8	IO90NDB5V1
J1	GFA2/IO117PSB6V1	L5	VCCIB6	N9	IO82NDB5V0
J2	GFA1/IO118PDB6V1	L6	GND	N10	IO74NDB4V1
J3	VCCPLF	L7	VCC	N11	IO74PDB4V1
J4	IO116NDB6V1	L8	VCC	N12	GNDQ
J5	GFB2/IO116PDB6V1	L9	VCC	N13	VCOMPLD
J6	VCC	L10	VCC	N14	VJTAG
J7	GND	L11	GND	N15	GDC0/IO65NDB3V1
J8	GND	L12	VCCIB3	N16	GDA1/IO67PDB3V1
J9	GND	L13	GDB0/IO66NPB3V1	P1	GEB1/IO103PDB6V0
J10	GND	L14	IO60NDB3V1	P2	GEB0/IO103NDB6V0
J11	VCC	L15	IO60PDB3V1	P3	VMV6
J12	GCB2/IO54PPB3V0	L16	IO61PDB3V1	P4	VCCPLE
J13	GCA1/IO52PPB3V0	M1	IO109NPB6V0	P5	IO101NPB5V2
J14	GCC2/IO55PPB3V0	M2	IO106NDB6V0	P6	IO95PPB5V1
J15	VCCPLC	M3	IO106PDB6V0	P7	IO92PDB5V1
J16	GCA2/IO53PSB3V0	M4	GEC0/IO104NPB6V0	P8	IO90PDB5V1

FG256	
Pin Number	AGLE600 Function
P9	IO82PDB5V0
P10	IO76NDB4V1
P11	IO76PDB4V1
P12	VMV4
P13	TCK
P14	VPUMP
P15	TRST
P16	GDA0/IO67NDB3V1
R1	GEA1/IO102PDB6V0
R2	GEA0/IO102NDB6V0
R3	GNDQ
R4	GEC2/IO99PDB5V2
R5	IO95NPB5V1
R6	IO91NDB5V1
R7	IO91PDB5V1
R8	IO83NDB5V0
R9	IO83PDB5V0
R10	IO77NDB4V1
R11	IO77PDB4V1
R12	IO69NDB4V0
R13	GDB2/IO69PDB4V0
R14	TDI
R15	GNDQ
R16	TDO
T1	GND
T2	IO100NDB5V2
T3	FF/GEB2/IO100PDB5 V2
T4	IO99NDB5V2
T5	IO88NDB5V0
T6	IO88PDB5V0
T7	IO89NSB5V0
T8	IO80NSB4V1
T9	IO81NDB4V1
T10	IO81PDB4V1
T11	IO70NDB4V0

FG256	
Pin Number	AGLE600 Function
T12	GDC2/IO70PDB4V0
T13	IO68NDB4V0
T14	GDA2/IO68PDB4V0
T15	TMS
T16	GND

# FG484

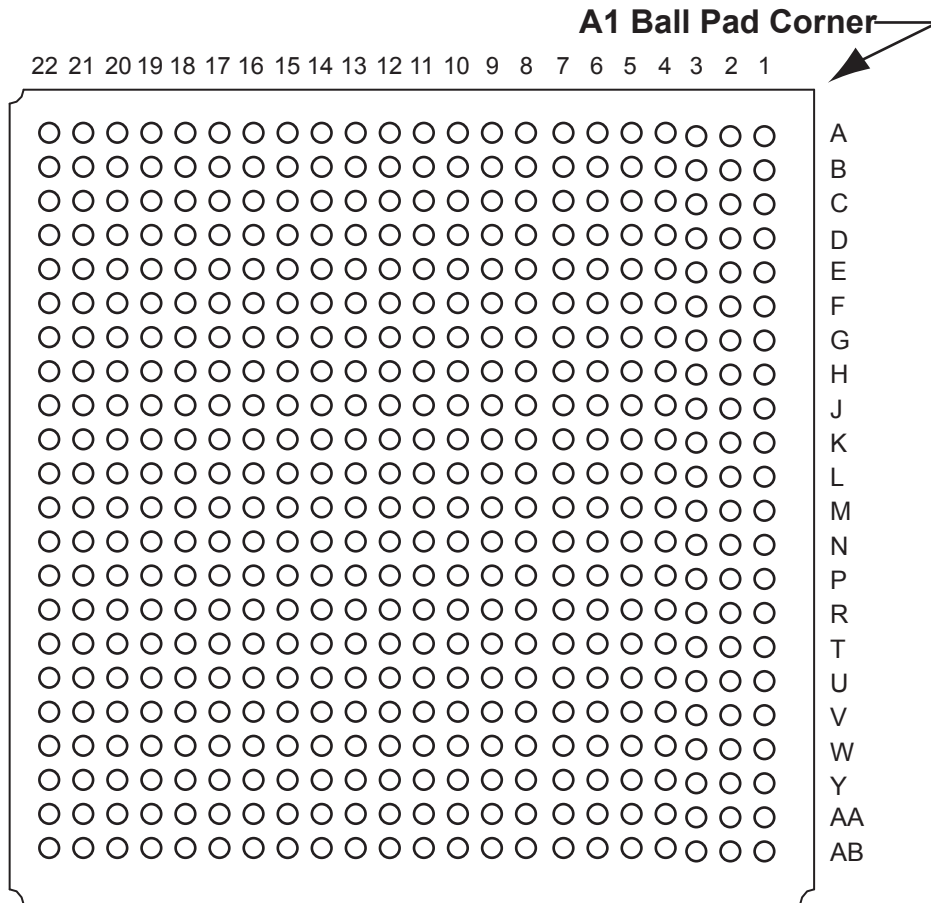

*Note:* This is the bottom view of the package.

## Note

For Package Manufacturing and Environmental information, visit the Resource Center at <http://www.microsemi.com/soc/products/solutions/package/docs.aspx>.

FG484		FG484		FG484	
Pin Number	AGLE600 Function	Pin Number	AGLE600 Function	Pin Number	AGLE600 Function
A1	GND	AA14	NC	B5	IO03PDB0V0
A2	GND	AA15	NC	B6	IO07NDB0V1
A3	VCCIB0	AA16	IO71NDB4V0	B7	IO07PDB0V1
A4	IO06NDB0V1	AA17	IO71PDB4V0	B8	IO11NDB0V1
A5	IO06PDB0V1	AA18	NC	B9	IO17NDB0V2
A6	IO08NDB0V1	AA19	NC	B10	IO14PDB0V2
A7	IO08PDB0V1	AA20	NC	B11	IO19PDB0V2
A8	IO11PDB0V1	AA21	VCCIB3	B12	IO22NDB1V0
A9	IO17PDB0V2	AA22	GND	B13	IO26NDB1V0
A10	IO18NDB0V2	AB1	GND	B14	NC
A11	IO18PDB0V2	AB2	GND	B15	NC
A12	IO22PDB1V0	AB3	VCCIB5	B16	IO30NDB1V1
A13	IO26PDB1V0	AB4	IO97NDB5V2	B17	IO30PDB1V1
A14	IO29NDB1V1	AB5	IO97PDB5V2	B18	IO32PDB1V1
A15	IO29PDB1V1	AB6	IO93NDB5V1	B19	NC
A16	IO31NDB1V1	AB7	IO93PDB5V1	B20	NC
A17	IO31PDB1V1	AB8	IO87NDB5V0	B21	VCCIB2
A18	IO32NDB1V1	AB9	IO87PDB5V0	B22	GND
A19	NC	AB10	NC	C1	VCCIB7
A20	VCCIB1	AB11	NC	C2	NC
A21	GND	AB12	IO75NDB4V1	C3	NC
A22	GND	AB13	IO75PDB4V1	C4	NC
AA1	GND	AB14	IO72NDB4V0	C5	GND
AA2	VCCIB6	AB15	IO72PDB4V0	C6	IO04NDB0V0
AA3	NC	AB16	IO73NDB4V0	C7	IO04PDB0V0
AA4	IO98PDB5V2	AB17	IO73PDB4V0	C8	VCC
AA5	IO96NDB5V2	AB18	NC	C9	VCC
AA6	IO96PDB5V2	AB19	NC	C10	IO14NDB0V2
AA7	IO86NDB5V0	AB20	VCCIB4	C11	IO19NDB0V2
AA8	IO86PDB5V0	AB21	GND	C12	NC
AA9	IO85PDB5V0	AB22	GND	C13	NC
AA10	IO85NDB5V0	B1	GND	C14	VCC
AA11	IO78PPB4V1	B2	VCCIB7	C15	VCC
AA12	IO79NDB4V1	B3	NC	C16	NC
AA13	IO79PDB4V1	B4	IO03NDB0V0	C17	NC

FG484		FG484		FG484	
Pin Number	AGLE600 Function	Pin Number	AGLE600 Function	Pin Number	AGLE600 Function
C18	GND	E9	IO10NDB0V1	F22	NC
C19	NC	E10	IO12NDB0V2	G1	IO127NDB7V1
C20	NC	E11	IO16PDB0V2	G2	IO127PDB7V1
C21	NC	E12	IO20NDB1V0	G3	NC
C22	VCCIB2	E13	IO24NDB1V0	G4	IO128PDB7V1
D1	NC	E14	IO24PDB1V0	G5	IO129PDB7V1
D2	NC	E15	GBC1/IO33PDB1V1	G6	GAC2/IO132PDB7V1
D3	NC	E16	GBB0/IO34NDB1V1	G7	VCOMPLA
D4	GND	E17	GNDQ	G8	GNDQ
D5	GAA0/IO00NDB0V0	E18	GBA2/IO36PDB2V0	G9	IO09NDB0V1
D6	GAA1/IO00PDB0V0	E19	IO42NDB2V0	G10	IO09PDB0V1
D7	GAB0/IO01NDB0V0	E20	GND	G11	IO13PDB0V2
D8	IO05PDB0V0	E21	NC	G12	IO21PDB1V0
D9	IO10PDB0V1	E22	NC	G13	IO25PDB1V0
D10	IO12PDB0V2	F1	NC	G14	IO27NDB1V0
D11	IO16NDB0V2	F2	IO131NDB7V1	G15	GNDQ
D12	IO23NDB1V0	F3	IO131PDB7V1	G16	VCOMPLB
D13	IO23PDB1V0	F4	IO133NDB7V1	G17	GBB2/IO37PDB2V0
D14	IO28NDB1V1	F5	IO134NDB7V1	G18	IO39PDB2V0
D15	IO28PDB1V1	F6	VMV7	G19	IO39NDB2V0
D16	GBB1/IO34PDB1V1	F7	VCCPLA	G20	IO43PDB2V0
D17	GBA0/IO35NDB1V1	F8	GAC0/IO02NDB0V0	G21	IO43NDB2V0
D18	GBA1/IO35PDB1V1	F9	GAC1/IO02PDB0V0	G22	NC
D19	GND	F10	IO15NDB0V2	H1	NC
D20	NC	F11	IO15PDB0V2	H2	NC
D21	NC	F12	IO20PDB1V0	H3	VCC
D22	NC	F13	IO25NDB1V0	H4	IO128NDB7V1
E1	NC	F14	IO27PDB1V0	H5	IO129NDB7V1
E2	NC	F15	GBC0/IO33NDB1V1	H6	IO132NDB7V1
E3	GND	F16	VCCPLB	H7	IO130PDB7V1
E4	GAB2/IO133PDB7V1	F17	VMV2	H8	VMV0
E5	GAA2/IO134PDB7V1	F18	IO36NDB2V0	H9	VCCIB0
E6	GNDQ	F19	IO42PDB2V0	H10	VCCIB0
E7	GAB1/IO01PDB0V0	F20	NC	H11	IO13NDB0V2
E8	IO05NDB0V0	F21	NC	H12	IO21NDB1V0

FG484		FG484		FG484	
Pin Number	AGLE600 Function	Pin Number	AGLE600 Function	Pin Number	AGLE600 Function
H13	VCCIB1	K4	IO124NDB7V0	L17	GCA0/IO52NPB3V0
H14	VCCIB1	K5	IO125NDB7V0	L18	VCOMPLC
H15	VMV1	K6	IO126NDB7V0	L19	GCB0/IO51NPB2V1
H16	GBC2/IO38PDB2V0	K7	GFC1/IO120PPB7V0	L20	IO49PPB2V1
H17	IO37NDB2V0	K8	VCCIB7	L21	IO47NDB2V1
H18	IO41NDB2V0	K9	VCC	L22	IO47PDB2V1
H19	IO41PDB2V0	K10	GND	M1	NC
H20	VCC	K11	GND	M2	IO114NPB6V1
H21	NC	K12	GND	M3	IO117NDB6V1
H22	NC	K13	GND	M4	GFA2/IO117PDB6V1
J1	IO123NDB7V0	K14	VCC	M5	GFA1/IO118PDB6V1
J2	IO123PDB7V0	K15	VCCIB2	M6	VCCPLF
J3	NC	K16	GCC1/IO50PPB2V1	M7	IO116NDB6V1
J4	IO124PDB7V0	K17	IO44NDB2V1	M8	GFB2/IO116PDB6V1
J5	IO125PDB7V0	K18	IO44PDB2V1	M9	VCC
J6	IO126PDB7V0	K19	IO49NPB2V1	M10	GND
J7	IO130NDB7V1	K20	IO45NPB2V1	M11	GND
J8	VCCIB7	K21	IO48NDB2V1	M12	GND
J9	GND	K22	IO46NDB2V1	M13	GND
J10	VCC	L1	NC	M14	VCC
J11	VCC	L2	IO122PDB7V0	M15	GCB2/IO54PPB3V0
J12	VCC	L3	IO122NDB7V0	M16	GCA1/IO52PPB3V0
J13	VCC	L4	GFB0/IO119NPB7V0	M17	GCC2/IO55PPB3V0
J14	GND	L5	GFA0/IO118NDB6V1	M18	VCCPLC
J15	VCCIB2	L6	GFB1/IO119PPB7V0	M19	GCA2/IO53PDB3V0
J16	IO38NDB2V0	L7	VCOMPLF	M20	IO53NDB3V0
J17	IO40NDB2V0	L8	GFC0/IO120NPB7V0	M21	IO56PDB3V0
J18	IO40PDB2V0	L9	VCC	M22	NC
J19	IO45PPB2V1	L10	GND	N1	IO114PPB6V1
J20	NC	L11	GND	N2	IO111NDB6V1
J21	IO48PDB2V1	L12	GND	N3	NC
J22	IO46PDB2V1	L13	GND	N4	GFC2/IO115PPB6V1
K1	IO121NDB7V0	L14	VCC	N5	IO113PPB6V1
K2	IO121PDB7V0	L15	GCC0/IO50NPB2V1	N6	IO112PDB6V1
K3	NC	L16	GCB1/IO51PPB2V1	N7	IO112NDB6V1

FG484		FG484		FG484	
Pin Number	AGLE600 Function	Pin Number	AGLE600 Function	Pin Number	AGLE600 Function
N8	VCCIB6	P21	IO59PDB3V0	T12	IO82NDB5V0
N9	VCC	P22	IO58NDB3V0	T13	IO74NDB4V1
N10	GND	R1	NC	T14	IO74PDB4V1
N11	GND	R2	IO110PDB6V0	T15	GNDQ
N12	GND	R3	VCC	T16	VCOMPLD
N13	GND	R4	IO109NPB6V0	T17	VJTAG
N14	VCC	R5	IO106NDB6V0	T18	GDC0/IO65NDB3V1
N15	VCCIB3	R6	IO106PDB6V0	T19	GDA1/IO67PDB3V1
N16	IO54NPB3V0	R7	GEC0/IO104NPB6V0	T20	NC
N17	IO57NPB3V0	R8	VMV5	T21	IO64PDB3V1
N18	IO55NPB3V0	R9	VCCIB5	T22	IO62NDB3V1
N19	IO57PPB3V0	R10	VCCIB5	U1	NC
N20	NC	R11	IO84NDB5V0	U2	IO107PDB6V0
N21	IO56NDB3V0	R12	IO84PDB5V0	U3	IO107NDB6V0
N22	IO58PDB3V0	R13	VCCIB4	U4	GEB1/IO103PDB6V0
P1	NC	R14	VCCIB4	U5	GEB0/IO103NDB6V0
P2	IO111PDB6V1	R15	VMV3	U6	VMV6
P3	IO115NPB6V1	R16	VCCPLD	U7	VCCPLE
P4	IO113NPB6V1	R17	GDB1/IO66PPB3V1	U8	IO101NPB5V2
P5	IO109PPB6V0	R18	GDC1/IO65PDB3V1	U9	IO95PPB5V1
P6	IO108PDB6V0	R19	IO61NDB3V1	U10	IO92PDB5V1
P7	IO108NDB6V0	R20	VCC	U11	IO90PDB5V1
P8	VCCIB6	R21	IO59NDB3V0	U12	IO82PDB5V0
P9	GND	R22	IO62PDB3V1	U13	IO76NDB4V1
P10	VCC	T1	NC	U14	IO76PDB4V1
P11	VCC	T2	IO110NDB6V0	U15	VMV4
P12	VCC	T3	NC	U16	TCK
P13	VCC	T4	IO105PDB6V0	U17	VPUMP
P14	GND	T5	IO105NDB6V0	U18	TRST
P15	VCCIB3	T6	GEC1/IO104PPB6V0	U19	GDA0/IO67NDB3V1
P16	GDB0/IO66NPB3V1	T7	VCOMPLE	U20	NC
P17	IO60NDB3V1	T8	GNDQ	U21	IO64NDB3V1
P18	IO60PDB3V1	T9	GEA2/IO101PPB5V2	U22	IO63PDB3V1
P19	IO61PDB3V1	T10	IO92NDB5V1	V1	NC
P20	NC	T11	IO90NDB5V1	V2	NC

FG484	
Pin Number	AGLE600 Function
V3	GND
V4	GEA1/IO102PDB6V0
V5	GEA0/IO102NDB6V0
V6	GNDQ
V7	GEC2/IO99PDB5V2
V8	IO95NPB5V1
V9	IO91NDB5V1
V10	IO91PDB5V1
V11	IO83NDB5V0
V12	IO83PDB5V0
V13	IO77NDB4V1
V14	IO77PDB4V1
V15	IO69NDB4V0
V16	GDB2/IO69PDB4V0
V17	TDI
V18	GNDQ
V19	TDO
V20	GND
V21	NC
V22	IO63NDB3V1
W1	NC
W2	NC
W3	NC
W4	GND
W5	IO100NDB5V2
W6	FF/GEB2/IO100PDB5V2
W7	IO99NDB5V2
W8	IO88NDB5V0
W9	IO88PDB5V0
W10	IO89NDB5V0
W11	IO80NDB4V1
W12	IO81NDB4V1
W13	IO81PDB4V1
W14	IO70NDB4V0
W15	GDC2/IO70PDB4V0

FG484	
Pin Number	AGLE600 Function
W16	IO68NDB4V0
W17	GDA2/IO68PDB4V0
W18	TMS
W19	GND
W20	NC
W21	NC
W22	NC
Y1	VCCIB6
Y2	NC
Y3	NC
Y4	IO98NDB5V2
Y5	GND
Y6	IO94NDB5V1
Y7	IO94PDB5V1
Y8	VCC
Y9	VCC
Y10	IO89PDB5V0
Y11	IO80PDB4V1
Y12	IO78NPB4V1
Y13	NC
Y14	VCC
Y15	VCC
Y16	NC
Y17	NC
Y18	GND
Y19	NC
Y20	NC
Y21	NC
Y22	VCCIB3

FG484	
Pin Number	AGLE3000 Function
A1	GND
A2	GND
A3	VCCIB0
A4	IO10NDB0V1
A5	IO10PDB0V1
A6	IO16NDB0V1
A7	IO16PDB0V1
A8	IO18PDB0V2
A9	IO24PDB0V2
A10	IO28NDB0V3
A11	IO28PDB0V3
A12	IO46PDB1V0
A13	IO54PDB1V1
A14	IO56NDB1V1
A15	IO56PDB1V1
A16	IO64NDB1V2
A17	IO64PDB1V2
A18	IO72NDB1V3
A19	IO74NDB1V4
A20	VCCIB1
A21	GND
A22	GND
AA1	GND
AA2	VCCIB6
AA3	IO228PDB5V4
AA4	IO224PDB5V3
AA5	IO218NDB5V3
AA6	IO218PDB5V3
AA7	IO212NDB5V2
AA8	IO212PDB5V2
AA9	IO198PDB5V0
AA10	IO198NDB5V0
AA11	IO188PPB4V4
AA12	IO180NDB4V3
AA13	IO180PDB4V3

FG484	
Pin Number	AGLE3000 Function
AA14	IO170NDB4V2
AA15	IO170PDB4V2
AA16	IO166NDB4V1
AA17	IO166PDB4V1
AA18	IO160NDB4V0
AA19	IO160PDB4V0
AA20	IO158NPB4V0
AA21	VCCIB3
AA22	GND
AB1	GND
AB2	GND
AB3	VCCIB5
AB4	IO216NDB5V2
AB5	IO216PDB5V2
AB6	IO210NDB5V2
AB7	IO210PDB5V2
AB8	IO208NDB5V1
AB9	IO208PDB5V1
AB10	IO197NDB5V0
AB11	IO197PDB5V0
AB12	IO174NDB4V2
AB13	IO174PDB4V2
AB14	IO172NDB4V2
AB15	IO172PDB4V2
AB16	IO168NDB4V1
AB17	IO168PDB4V1
AB18	IO162NDB4V1
AB19	IO162PDB4V1
AB20	VCCIB4
AB21	GND
AB22	GND
B1	GND
B2	VCCIB7
B3	IO06PPB0V0
B4	IO08NDB0V0

FG484	
Pin Number	AGLE3000 Function
B5	IO08PDB0V0
B6	IO14NDB0V1
B7	IO14PDB0V1
B8	IO18NDB0V2
B9	IO24NDB0V2
B10	IO34PDB0V4
B11	IO40PDB0V4
B12	IO46NDB1V0
B13	IO54NDB1V1
B14	IO62NDB1V2
B15	IO62PDB1V2
B16	IO68NDB1V3
B17	IO68PDB1V3
B18	IO72PDB1V3
B19	IO74PDB1V4
B20	IO76NPB1V4
B21	VCCIB2
B22	GND
C1	VCCIB7
C2	IO303PDB7V3
C3	IO305PDB7V3
C4	IO06NPB0V0
C5	GND
C6	IO12NDB0V1
C7	IO12PDB0V1
C8	VCC
C9	VCC
C10	IO34NDB0V4
C11	IO40NDB0V4
C12	IO48NDB1V0
C13	IO48PDB1V0
C14	VCC
C15	VCC
C16	IO70NDB1V3
C17	IO70PDB1V3

FG484	
Pin Number	AGLE3000 Function
C18	GND
C19	IO76PPB1V4
C20	IO88NDB2V0
C21	IO94PPB2V1
C22	VCCIB2
D1	IO293PDB7V2
D2	IO303NDB7V3
D3	IO305NDB7V3
D4	GND
D5	GAA0/IO00NDB0V0
D6	GAA1/IO00PDB0V0
D7	GAB0/IO01NDB0V0
D8	IO20PDB0V2
D9	IO22PDB0V2
D10	IO30PDB0V3
D11	IO38NDB0V4
D12	IO52NDB1V1
D13	IO52PDB1V1
D14	IO66NDB1V3
D15	IO66PDB1V3
D16	GBB1/IO80PDB1V4
D17	GBA0/IO81NDB1V4
D18	GBA1/IO81PDB1V4
D19	GND
D20	IO88PDB2V0
D21	IO90PDB2V1
D22	IO94NPB2V1
E1	IO293NDB7V2
E2	IO299PPB7V3
E3	GND
E4	GAB2/IO308PDB7V4
E5	GAA2/IO309PDB7V4
E6	GNDQ
E7	GAB1/IO01PDB0V0
E8	IO20NDB0V2

FG484	
Pin Number	AGLE3000 Function
E9	IO22NDB0V2
E10	IO30NDB0V3
E11	IO38PDB0V4
E12	IO44NDB1V0
E13	IO58NDB1V2
E14	IO58PDB1V2
E15	GBC1/IO79PDB1V4
E16	GBB0/IO80NDB1V4
E17	GNDQ
E18	GBA2/IO82PDB2V0
E19	IO86NDB2V0
E20	GND
E21	IO90NDB2V1
E22	IO98PDB2V2
F1	IO299NPB7V3
F2	IO301NDB7V3
F3	IO301PDB7V3
F4	IO308NDB7V4
F5	IO309NDB7V4
F6	VMV7
F7	VCCPLA
F8	GAC0/IO02NDB0V0
F9	GAC1/IO02PDB0V0
F10	IO32NDB0V3
F11	IO32PDB0V3
F12	IO44PDB1V0
F13	IO50NDB1V1
F14	IO60PDB1V2
F15	GBC0/IO79NDB1V4
F16	VCCPLB
F17	VMV2
F18	IO82NDB2V0
F19	IO86PDB2V0
F20	IO96PDB2V1
F21	IO96NDB2V1

FG484	
Pin Number	AGLE3000 Function
F22	IO98NDB2V2
G1	IO289NDB7V1
G2	IO289PDB7V1
G3	IO291PPB7V2
G4	IO295PDB7V2
G5	IO297PDB7V2
G6	GAC2/IO307PDB7V4
G7	VCOMPLA
G8	GNDQ
G9	IO26NDB0V3
G10	IO26PDB0V3
G11	IO36PDB0V4
G12	IO42PDB1V0
G13	IO50PDB1V1
G14	IO60NDB1V2
G15	GNDQ
G16	VCOMPLB
G17	GBB2/IO83PDB2V0
G18	IO92PDB2V1
G19	IO92NDB2V1
G20	IO102PDB2V2
G21	IO102NDB2V2
G22	IO105NDB2V2
H1	IO286PSB7V1
H2	IO291NPB7V2
H3	VCC
H4	IO295NDB7V2
H5	IO297NDB7V2
H6	IO307NDB7V4
H7	IO287PDB7V1
H8	VMV0
H9	VCCIB0
H10	VCCIB0
H11	IO36NDB0V4
H12	IO42NDB1V0

FG484	
Pin Number	AGLE3000 Function
H13	VCCIB1
H14	VCCIB1
H15	VMV1
H16	GBC2/IO84PDB2V0
H17	IO83NDB2V0
H18	IO100NDB2V2
H19	IO100PDB2V2
H20	VCC
H21	VMV2
H22	IO105PDB2V2
J1	IO285NDB7V1
J2	IO285PDB7V1
J3	VMV7
J4	IO279PDB7V0
J5	IO283PDB7V1
J6	IO281PDB7V0
J7	IO287NDB7V1
J8	VCCIB7
J9	GND
J10	VCC
J11	VCC
J12	VCC
J13	VCC
J14	GND
J15	VCCIB2
J16	IO84NDB2V0
J17	IO104NDB2V2
J18	IO104PDB2V2
J19	IO106PPB2V3
J20	GNDQ
J21	IO109PDB2V3
J22	IO107PDB2V3
K1	IO277NDB7V0
K2	IO277PDB7V0
K3	GNDQ

FG484	
Pin Number	AGLE3000 Function
K4	IO279NDB7V0
K5	IO283NDB7V1
K6	IO281NDB7V0
K7	GFC1/IO275PPB7V0
K8	VCCIB7
K9	VCC
K10	GND
K11	GND
K12	GND
K13	GND
K14	VCC
K15	VCCIB2
K16	GCC1/IO112PPB2V3
K17	IO108NDB2V3
K18	IO108PDB2V3
K19	IO110NPB2V3
K20	IO106NPB2V3
K21	IO109NDB2V3
K22	IO107NDB2V3
L1	IO257PSB6V2
L2	IO276PDB7V0
L3	IO276NDB7V0
L4	GFB0/IO274NPB7V0
L5	GFA0/IO273NDB6V4
L6	GFB1/IO274PPB7V0
L7	VCOMPLF
L8	GFC0/IO275NPB7V0
L9	VCC
L10	GND
L11	GND
L12	GND
L13	GND
L14	VCC
L15	GCC0/IO112NPB2V3
L16	GCB1/IO113PPB2V3

FG484	
Pin Number	AGLE3000 Function
L17	GCA0/IO114NPB3V0
L18	VCOMPLC
L19	GCB0/IO113NPB2V3
L20	IO110PPB2V3
L21	IO111NDB2V3
L22	IO111PDB2V3
M1	GNDQ
M2	IO255NPB6V2
M3	IO272NDB6V4
M4	GFA2/IO272PDB6V4
M5	GFA1/IO273PDB6V4
M6	VCCPLF
M7	IO271NDB6V4
M8	GFB2/IO271PDB6V4
M9	VCC
M10	GND
M11	GND
M12	GND
M13	GND
M14	VCC
M15	GCB2/IO116PPB3V0
M16	GCA1/IO114PPB3V0
M17	GCC2/IO117PPB3V0
M18	VCCPLC
M19	GCA2/IO115PDB3V0
M20	IO115NDB3V0
M21	IO126PDB3V1
M22	IO124PSB3V1
N1	IO255PPB6V2
N2	IO253NDB6V2
N3	VMV6
N4	GFC2/IO270PPB6V4
N5	IO261PPB6V3
N6	IO263PDB6V3
N7	IO263NDB6V3

FG484	
Pin Number	AGLE3000 Function
N8	VCCIB6
N9	VCC
N10	GND
N11	GND
N12	GND
N13	GND
N14	VCC
N15	VCCIB3
N16	IO116NPB3V0
N17	IO132NPB3V2
N18	IO117NPB3V0
N19	IO132PPB3V2
N20	GNDQ
N21	IO126NDB3V1
N22	IO128PDB3V1
P1	IO247PDB6V1
P2	IO253PDB6V2
P3	IO270NPB6V4
P4	IO261NPB6V3
P5	IO249PPB6V1
P6	IO259PDB6V3
P7	IO259NDB6V3
P8	VCCIB6
P9	GND
P10	VCC
P11	VCC
P12	VCC
P13	VCC
P14	GND
P15	VCCIB3
P16	GDB0/IO152NPB3V4
P17	IO136NDB3V2
P18	IO136PDB3V2
P19	IO138PDB3V3
P20	VMV3

FG484	
Pin Number	AGLE3000 Function
P21	IO130PDB3V2
P22	IO128NDB3V1
R1	IO247NDB6V1
R2	IO245PDB6V1
R3	VCC
R4	IO249NPB6V1
R5	IO251NDB6V2
R6	IO251PDB6V2
R7	GEC0/IO236NPB6V0
R8	VMV5
R9	VCCIB5
R10	VCCIB5
R11	IO196NDB5V0
R12	IO196PDB5V0
R13	VCCIB4
R14	VCCIB4
R15	VMV3
R16	VCCPLD
R17	GDB1/IO152PPB3V4
R18	GDC1/IO151PDB3V4
R19	IO138NDB3V3
R20	VCC
R21	IO130NDB3V2
R22	IO134PDB3V2
T1	IO243PPB6V1
T2	IO245NDB6V1
T3	IO243NPB6V1
T4	IO241PDB6V0
T5	IO241NDB6V0
T6	GEC1/IO236PPB6V0
T7	VCOMPLE
T8	GNDQ
T9	GEA2/IO233PPB5V4
T10	IO206NDB5V1
T11	IO202NDB5V1

FG484	
Pin Number	AGLE3000 Function
T12	IO194NDB5V0
T13	IO186NDB4V4
T14	IO186PDB4V4
T15	GNDQ
T16	VCOMPLD
T17	VJTAG
T18	GDC0/IO151NDB3V4
T19	GDA1/IO153PDB3V4
T20	IO144PDB3V3
T21	IO140PDB3V3
T22	IO134NDB3V2
U1	IO240PPB6V0
U2	IO238PDB6V0
U3	IO238NDB6V0
U4	GEB1/IO235PDB6V0
U5	GEB0/IO235NDB6V0
U6	VMV6
U7	VCCPLE
U8	IO233NPB5V4
U9	IO222PPB5V3
U10	IO206PDB5V1
U11	IO202PDB5V1
U12	IO194PDB5V0
U13	IO176NDB4V2
U14	IO176PDB4V2
U15	VMV4
U16	TCK
U17	VPUMP
U18	TRST
U19	GDA0/IO153NDB3V4
U20	IO144NDB3V3
U21	IO140NDB3V3
U22	IO142PDB3V3
V1	IO239PDB6V0
V2	IO240NPB6V0

FG484	
Pin Number	AGLE3000 Function
V3	GND
V4	GEA1/IO234PDB6V0
V5	GEA0/IO234NDB6V0
V6	GNDQ
V7	GEC2/IO231PDB5V4
V8	IO222NPB5V3
V9	IO204NDB5V1
V10	IO204PDB5V1
V11	IO195NDB5V0
V12	IO195PDB5V0
V13	IO178NDB4V3
V14	IO178PDB4V3
V15	IO155NDB4V0
V16	GDB2/IO155PDB4V0
V17	TDI
V18	GNDQ
V19	TDO
V20	GND
V21	IO146PDB3V4
V22	IO142NDB3V3
W1	IO239NDB6V0
W2	IO237PDB6V0
W3	IO230PSB5V4
W4	GND
W5	IO232NDB5V4
W6	FF/GEB2/IO232PDB5V4
W7	IO231NDB5V4
W8	IO214NDB5V2
W9	IO214PDB5V2
W10	IO200NDB5V0
W11	IO192NDB4V4
W12	IO184NDB4V3
W13	IO184PDB4V3
W14	IO156NDB4V0

FG484	
Pin Number	AGLE3000 Function
W15	GDC2/IO156PDB4V0
W16	IO154NDB4V0
W17	GDA2/IO154PDB4V0
W18	TMS
W19	GND
W20	IO150NDB3V4
W21	IO146NDB3V4
W22	IO148PPB3V4
Y1	VCCIB6
Y2	IO237NDB6V0
Y3	IO228NDB5V4
Y4	IO224NDB5V3
Y5	GND
Y6	IO220NDB5V3
Y7	IO220PDB5V3
Y8	VCC
Y9	VCC
Y10	IO200PDB5V0
Y11	IO192PDB4V4
Y12	IO188NPB4V4
Y13	IO187PSB4V4
Y14	VCC
Y15	VCC
Y16	IO164NDB4V1
Y17	IO164PDB4V1
Y18	GND
Y19	IO158PPB4V0
Y20	IO150PDB3V4
Y21	IO148NPB3V4
Y22	VCCIB3



FG896	
Pin Number	AGLE3000 Function
A2	GND
A3	GND
A4	IO14NPB0V1
A5	GND
A6	IO07NPB0V0
A7	GND
A8	IO09NDB0V1
A9	IO17NDB0V2
A10	IO17PDB0V2
A11	IO21NDB0V2
A12	IO21PDB0V2
A13	IO33NDB0V4
A14	IO33PDB0V4
A15	IO35NDB0V4
A16	IO35PDB0V4
A17	IO41NDB1V0
A18	IO43NDB1V0
A19	IO43PDB1V0
A20	IO45NDB1V0
A21	IO45PDB1V0
A22	IO57NDB1V2
A23	IO57PDB1V2
A24	GND
A25	IO69PPB1V3
A26	GND
A27	GBC1/IO79PPB1V4
A28	GND
A29	GND
AA1	IO256PDB6V2
AA2	IO248PDB6V1
AA3	IO248NDB6V1
AA4	IO246NDB6V1
AA5	GEA1/IO234PDB6V0
AA6	GEA0/IO234NDB6V0
AA7	IO243PPB6V1

FG896	
Pin Number	AGLE3000 Function
AA8	IO245NDB6V1
AA9	GEB1/IO235PPB6V0
AA10	VCC
AA11	IO226PPB5V4
AA12	VCCIB5
AA13	VCCIB5
AA14	VCCIB5
AA15	VCCIB5
AA16	VCCIB4
AA17	VCCIB4
AA18	VCCIB4
AA19	VCCIB4
AA20	IO174PDB4V2
AA21	VCC
AA22	IO142NPB3V3
AA23	IO144NDB3V3
AA24	IO144PDB3V3
AA25	IO146NDB3V4
AA26	IO146PDB3V4
AA27	IO147PDB3V4
AA28	IO139NDB3V3
AA29	IO139PDB3V3
AA30	IO133NDB3V2
AB1	IO256NDB6V2
AB2	IO244PDB6V1
AB3	IO244NDB6V1
AB4	IO241PDB6V0
AB5	IO241NDB6V0
AB6	IO243NPB6V1
AB7	VCCIB6
AB8	VCCPLE
AB9	VCC
AB10	IO222PDB5V3
AB11	IO218PPB5V3
AB12	IO206NDB5V1

FG896	
Pin Number	AGLE3000 Function
AB13	IO206PDB5V1
AB14	IO198NDB5V0
AB15	IO198PDB5V0
AB16	IO192NDB4V4
AB17	IO192PDB4V4
AB18	IO178NDB4V3
AB19	IO178PDB4V3
AB20	IO174NDB4V2
AB21	IO162NPB4V1
AB22	VCC
AB23	VCCPLD
AB24	VCCIB3
AB25	IO150PDB3V4
AB26	IO148PDB3V4
AB27	IO147NDB3V4
AB28	IO145PDB3V3
AB29	IO143PDB3V3
AB30	IO137PDB3V2
AC1	IO254PDB6V2
AC2	IO254NDB6V2
AC3	IO240PDB6V0
AC4	GEC1/IO236PDB6V0
AC5	IO237PDB6V0
AC6	IO237NDB6V0
AC7	VCOMPLE
AC8	GND
AC9	IO226NPB5V4
AC10	IO222NDB5V3
AC11	IO216NPB5V2
AC12	IO210NPB5V2
AC13	IO204NDB5V1
AC14	IO204PDB5V1
AC15	IO194NDB5V0
AC16	IO188NDB4V4
AC17	IO188PDB4V4

FG896	
Pin Number	AGLE3000 Function
AC18	IO182PPB4V3
AC19	IO170NPB4V2
AC20	IO164NDB4V1
AC21	IO164PDB4V1
AC22	IO162PPB4V1
AC23	GND
AC24	VCOMPLD
AC25	IO150NDB3V4
AC26	IO148NDB3V4
AC27	GDA1/IO153PDB3V4
AC28	IO145NDB3V3
AC29	IO143NDB3V3
AC30	IO137NDB3V2
AD1	GND
AD2	IO242NPB6V1
AD3	IO240NDB6V0
AD4	GEC0/IO236NDB6V0
AD5	VCCIB6
AD6	GNDQ
AD6	GNDQ
AD7	VCC
AD8	VMV5
AD9	VCCIB5
AD10	IO224PPB5V3
AD11	IO218NPB5V3
AD12	IO216PPB5V2
AD13	IO210PPB5V2
AD14	IO202PPB5V1
AD15	IO194PDB5V0
AD16	IO190PDB4V4
AD17	IO182NPB4V3
AD18	IO176NDB4V2
AD19	IO176PDB4V2
AD20	IO170PPB4V2
AD21	IO166PDB4V1

FG896	
Pin Number	AGLE3000 Function
AD22	VCCIB4
AD23	TCK
AD24	VCC
AD25	TRST
AD26	VCCIB3
AD27	GDA0/IO153NDB3V4
AD28	GDC0/IO151NDB3V4
AD29	GDC1/IO151PDB3V4
AD30	GND
AE1	IO242PPB6V1
AE2	VCC
AE3	IO239PDB6V0
AE4	IO239NDB6V0
AE5	VMV6
AE5	VMV6
AE6	GND
AE7	GNDQ
AE8	IO230NDB5V4
AE9	IO224NPB5V3
AE10	IO214NPB5V2
AE11	IO212NDB5V2
AE12	IO212PDB5V2
AE13	IO202NPB5V1
AE14	IO200NDB5V0
AE15	IO196PDB5V0
AE16	IO190NDB4V4
AE17	IO184PDB4V3
AE18	IO184NDB4V3
AE19	IO172PDB4V2
AE20	IO172NDB4V2
AE21	IO166NDB4V1
AE22	IO160PDB4V0
AE23	GNDQ
AE24	VMV4
AE25	GND

FG896	
Pin Number	AGLE3000 Function
AE26	GDB0/IO152NDB3V4
AE27	GDB1/IO152PDB3V4
AE28	VMV3
AE28	VMV3
AE29	VCC
AE30	IO149PDB3V4
AF1	GND
AF2	IO238PPB6V0
AF3	VCCIB6
AF4	IO220NPB5V3
AF5	VCC
AF6	IO228NDB5V4
AF7	VCCIB5
AF8	IO230PDB5V4
AF9	IO229NDB5V4
AF10	IO229PDB5V4
AF11	IO214PPB5V2
AF12	IO208NDB5V1
AF13	IO208PDB5V1
AF14	IO200PDB5V0
AF15	IO196NDB5V0
AF16	IO186NDB4V4
AF17	IO186PDB4V4
AF18	IO180NDB4V3
AF19	IO180PDB4V3
AF20	IO168NDB4V1
AF21	IO168PDB4V1
AF22	IO160NDB4V0
AF23	IO158NPB4V0
AF24	VCCIB4
AF25	IO154NPB4V0
AF26	VCC
AF27	TDO
AF28	VCCIB3
AF29	GNDQ

FG896	
Pin Number	AGLE3000 Function
AF29	GNDQ
AF30	GND
AG1	IO238NPB6V0
AG2	VCC
AG3	IO232NPB5V4
AG4	GND
AG5	IO220PPB5V3
AG6	IO228PDB5V4
AG7	IO231NDB5V4
AG8	GEC2/IO231PDB5V4
AG9	IO225NPB5V3
AG10	IO223NPB5V3
AG11	IO221PDB5V3
AG12	IO221NDB5V3
AG13	IO205NPB5V1
AG14	IO199NDB5V0
AG15	IO199PDB5V0
AG16	IO187NDB4V4
AG17	IO187PDB4V4
AG18	IO181NDB4V3
AG19	IO171PPB4V2
AG20	IO165NPB4V1
AG21	IO161NPB4V0
AG22	IO159NDB4V0
AG23	IO159PDB4V0
AG24	IO158PPB4V0
AG25	GDB2/IO155PDB4V0
AG26	GDA2/IO154PPB4V0
AG27	GND
AG28	VJTAG
AG29	VCC
AG30	IO149NDB3V4
AH1	GND
AH2	IO233NPB5V4
AH3	VCC

FG896	
Pin Number	AGLE3000 Function
AH4	FF/GEB2/IO232PPB5V4
AH5	VCCIB5
AH6	IO219NDB5V3
AH7	IO219PDB5V3
AH8	IO227NDB5V4
AH9	IO227PDB5V4
AH10	IO225PPB5V3
AH11	IO223PPB5V3
AH12	IO211NDB5V2
AH13	IO211PDB5V2
AH14	IO205PPB5V1
AH15	IO195NDB5V0
AH16	IO185NDB4V3
AH17	IO185PDB4V3
AH18	IO181PDB4V3
AH19	IO177NDB4V2
AH20	IO171NPB4V2
AH21	IO165PPB4V1
AH22	IO161PPB4V0
AH23	IO157NDB4V0
AH24	IO157PDB4V0
AH25	IO155NDB4V0
AH26	VCCIB4
AH27	TDI
AH28	VCC
AH29	VPUMP
AH30	GND
AJ1	GND
AJ2	GND
AJ3	GEA2/IO233PPB5V4
AJ4	VCC
AJ5	IO217NPB5V2
AJ6	VCC
AJ7	IO215NPB5V2

FG896	
Pin Number	AGLE3000 Function
AJ8	IO213NDB5V2
AJ9	IO213PDB5V2
AJ10	IO209NDB5V1
AJ11	IO209PDB5V1
AJ12	IO203NDB5V1
AJ13	IO203PDB5V1
AJ14	IO197NDB5V0
AJ15	IO195PDB5V0
AJ16	IO183NDB4V3
AJ17	IO183PDB4V3
AJ18	IO179NPB4V3
AJ19	IO177PDB4V2
AJ20	IO173NDB4V2
AJ21	IO173PDB4V2
AJ22	IO163NDB4V1
AJ23	IO163PDB4V1
AJ24	IO167NPB4V1
AJ25	VCC
AJ26	IO156NPB4V0
AJ27	VCC
AJ28	TMS
AJ29	GND
AJ30	GND
AK2	GND
AK3	GND
AK4	IO217PPB5V2
AK5	GND
AK6	IO215PPB5V2
AK7	GND
AK8	IO207NDB5V1
AK9	IO207PDB5V1
AK10	IO201NDB5V0
AK11	IO201PDB5V0
AK12	IO193NDB4V4
AK13	IO193PDB4V4

FG896	
Pin Number	AGLE3000 Function
AK14	IO197PDB5V0
AK15	IO191NDB4V4
AK16	IO191PDB4V4
AK17	IO189NDB4V4
AK18	IO189PDB4V4
AK19	IO179PPB4V3
AK20	IO175NDB4V2
AK21	IO175PDB4V2
AK22	IO169NDB4V1
AK23	IO169PDB4V1
AK24	GND
AK25	IO167PPB4V1
AK26	GND
AK27	GDC2/IO156PPB4V0
AK28	GND
AK29	GND
B1	GND
B2	GND
B3	GAA2/IO309PPB7V4
B4	VCC
B5	IO14PPB0V1
B6	VCC
B7	IO07PPB0V0
B8	IO09PDB0V1
B9	IO15PPB0V1
B10	IO19NDB0V2
B11	IO19PDB0V2
B12	IO29NDB0V3
B13	IO29PDB0V3
B14	IO31PPB0V3
B15	IO37NDB0V4
B16	IO37PDB0V4
B17	IO41PDB1V0
B18	IO51NDB1V1
B19	IO59PDB1V2

FG896	
Pin Number	AGLE3000 Function
B20	IO53PDB1V1
B21	IO53NDB1V1
B22	IO61NDB1V2
B23	IO61PDB1V2
B24	IO69NPB1V3
B25	VCC
B26	GBC0/IO79NPB1V4
B27	VCC
B28	IO64NPB1V2
B29	GND
B30	GND
C1	GND
C2	IO309NPB7V4
C3	VCC
C4	GAA0/IO00NPB0V0
C5	VCCIB0
C6	IO03PDB0V0
C7	IO03NDB0V0
C8	GAB1/IO01PDB0V0
C9	IO05PDB0V0
C10	IO15NPB0V1
C11	IO25NDB0V3
C12	IO25PDB0V3
C13	IO31NPB0V3
C14	IO27NDB0V3
C15	IO39NDB0V4
C16	IO39PDB0V4
C17	IO55PPB1V1
C18	IO51PDB1V1
C19	IO59NDB1V2
C20	IO63NDB1V2
C21	IO63PDB1V2
C22	IO67NDB1V3
C23	IO67PDB1V3
C24	IO75NDB1V4

FG896	
Pin Number	AGLE3000 Function
C25	IO75PDB1V4
C26	VCCIB1
C27	IO64PPB1V2
C28	VCC
C29	GBA1/IO81PPB1V4
C30	GND
D1	IO303PPB7V3
D2	VCC
D3	IO305NPB7V3
D4	GND
D5	GAA1/IO00PPB0V0
D6	GAC1/IO02PDB0V0
D7	IO06NPB0V0
D8	GAB0/IO01NDB0V0
D9	IO05NDB0V0
D10	IO11NDB0V1
D11	IO11PDB0V1
D12	IO23NDB0V2
D13	IO23PDB0V2
D14	IO27PDB0V3
D15	IO40PDB0V4
D16	IO47NDB1V0
D17	IO47PDB1V0
D18	IO55NPB1V1
D19	IO65NDB1V3
D20	IO65PDB1V3
D21	IO71NDB1V3
D22	IO71PDB1V3
D23	IO73NDB1V4
D24	IO73PDB1V4
D25	IO74NDB1V4
D26	GBB0/IO80NPB1V4
D27	GND
D28	GBA0/IO81NPB1V4
D29	VCC

FG896	
Pin Number	AGLE3000 Function
D30	GBA2/IO82PPB2V0
E1	GND
E2	IO303NPB7V3
E3	VCCIB7
E4	IO305PPB7V3
E5	VCC
E6	GAC0/IO02NDB0V0
E7	VCCIB0
E8	IO06PPB0V0
E9	IO24NDB0V2
E10	IO24PDB0V2
E11	IO13NDB0V1
E12	IO13PDB0V1
E13	IO34NDB0V4
E14	IO34PDB0V4
E15	IO40NDB0V4
E16	IO49NDB1V1
E17	IO49PDB1V1
E18	IO50PDB1V1
E19	IO58PDB1V2
E20	IO60NDB1V2
E21	IO77PDB1V4
E22	IO68NDB1V3
E23	IO68PDB1V3
E24	VCCIB1
E25	IO74PDB1V4
E26	VCC
E27	GBB1/IO80PPB1V4
E28	VCCIB2
E29	IO82NPB2V0
E30	GND
F1	IO296PPB7V2
F2	VCC
F3	IO306PDB7V4
F4	IO297PDB7V2

FG896	
Pin Number	AGLE3000 Function
F5	VMV7
F5	VMV7
F6	GND
F7	GNDQ
F8	IO12NDB0V1
F9	IO12PDB0V1
F10	IO10PDB0V1
F11	IO16PDB0V1
F12	IO22NDB0V2
F13	IO30NDB0V3
F14	IO30PDB0V3
F15	IO36PDB0V4
F16	IO48NDB1V0
F17	IO48PDB1V0
F18	IO50NDB1V1
F19	IO58NDB1V2
F20	IO60PDB1V2
F21	IO77NDB1V4
F22	IO72NDB1V3
F23	IO72PDB1V3
F24	GNDQ
F25	GND
F26	VMV2
F26	VMV2
F27	IO86PDB2V0
F28	IO92PDB2V1
F29	VCC
F30	IO100NPB2V2
G1	GND
G2	IO296NPB7V2
G3	IO306NDB7V4
G4	IO297NDB7V2
G5	VCCIB7
G6	GNDQ
G6	GNDQ

FG896	
Pin Number	AGLE3000 Function
G7	VCC
G8	VMV0
G9	VCCIB0
G10	IO10NDB0V1
G11	IO16NDB0V1
G12	IO22PDB0V2
G13	IO26PPB0V3
G14	IO38NPB0V4
G15	IO36NDB0V4
G16	IO46NDB1V0
G17	IO46PDB1V0
G18	IO56NDB1V1
G19	IO56PDB1V1
G20	IO66NDB1V3
G21	IO66PDB1V3
G22	VCCIB1
G23	VMV1
G24	VCC
G25	GNDQ
G25	GNDQ
G26	VCCIB2
G27	IO86NDB2V0
G28	IO92NDB2V1
G29	IO100PPB2V2
G30	GND
H1	IO294PDB7V2
H2	IO294NDB7V2
H3	IO300NDB7V3
H4	IO300PDB7V3
H5	IO295PDB7V2
H6	IO299PDB7V3
H7	VCOMPLA
H8	GND
H9	IO08NDB0V0
H10	IO08PDB0V0

FG896	
Pin Number	AGLE3000 Function
H11	IO18PDB0V2
H12	IO26NPB0V3
H13	IO28NDB0V3
H14	IO28PDB0V3
H15	IO38PPB0V4
H16	IO42NDB1V0
H17	IO52NDB1V1
H18	IO52PDB1V1
H19	IO62NDB1V2
H20	IO62PDB1V2
H21	IO70NDB1V3
H22	IO70PDB1V3
H23	GND
H24	VCOMPLB
H25	GBC2/IO84PDB2V0
H26	IO84NDB2V0
H27	IO96PDB2V1
H28	IO96NDB2V1
H29	IO89PDB2V0
H30	IO89NDB2V0
J1	IO290NDB7V2
J2	IO290PDB7V2
J3	IO302NDB7V3
J4	IO302PDB7V3
J5	IO295NDB7V2
J6	IO299NDB7V3
J7	VCCIB7
J8	VCCPLA
J9	VCC
J10	IO04NPB0V0
J11	IO18NDB0V2
J12	IO20NDB0V2
J13	IO20PDB0V2
J14	IO32NDB0V3
J15	IO32PDB0V3

FG896	
Pin Number	AGLE3000 Function
J16	IO42PDB1V0
J17	IO44NDB1V0
J18	IO44PDB1V0
J19	IO54NDB1V1
J20	IO54PDB1V1
J21	IO76NPB1V4
J22	VCC
J23	VCCPLB
J24	VCCIB2
J25	IO90PDB2V1
J26	IO90NDB2V1
J27	GBB2/IO83PDB2V0
J28	IO83NDB2V0
J29	IO91PDB2V1
J30	IO91NDB2V1
K1	IO288NDB7V1
K2	IO288PDB7V1
K3	IO304NDB7V3
K4	IO304PDB7V3
K5	GAB2/IO308PDB7V4
K6	IO308NDB7V4
K7	IO301PDB7V3
K8	IO301NDB7V3
K9	GAC2/IO307PPB7V4
K10	VCC
K11	IO04PPB0V0
K12	VCCIB0
K13	VCCIB0
K14	VCCIB0
K15	VCCIB0
K16	VCCIB1
K17	VCCIB1
K18	VCCIB1
K19	VCCIB1
K20	IO76PPB1V4

FG896	
Pin Number	AGLE3000 Function
K21	VCC
K22	IO78PPB1V4
K23	IO88NDB2V0
K24	IO88PDB2V0
K25	IO94PDB2V1
K26	IO94NDB2V1
K27	IO85PDB2V0
K28	IO85NDB2V0
K29	IO93PDB2V1
K30	IO93NDB2V1
L1	IO286NDB7V1
L2	IO286PDB7V1
L3	IO298NDB7V3
L4	IO298PDB7V3
L5	IO283PDB7V1
L6	IO291NDB7V2
L7	IO291PDB7V2
L8	IO293PDB7V2
L9	IO293NDB7V2
L10	IO307NPB7V4
L11	VCC
L12	VCC
L13	VCC
L14	VCC
L15	VCC
L16	VCC
L17	VCC
L18	VCC
L19	VCC
L20	VCC
L21	IO78NPB1V4
L22	IO104NPB2V2
L23	IO98NDB2V2
L24	IO98PDB2V2
L25	IO87PDB2V0

FG896	
Pin Number	AGLE3000 Function
L26	IO87NDB2V0
L27	IO97PDB2V1
L28	IO101PDB2V2
L29	IO103PDB2V2
L30	IO119NDB3V0
M1	IO282NDB7V1
M2	IO282PDB7V1
M3	IO292NDB7V2
M4	IO292PDB7V2
M5	IO283NDB7V1
M6	IO285PDB7V1
M7	IO287PDB7V1
M8	IO289PDB7V1
M9	IO289NDB7V1
M10	VCCIB7
M11	VCC
M12	GND
M13	GND
M14	GND
M15	GND
M16	GND
M17	GND
M18	GND
M19	GND
M20	VCC
M21	VCCIB2
M22	NC
M23	IO104PPB2V2
M24	IO102PDB2V2
M25	IO102NDB2V2
M26	IO95PDB2V1
M27	IO97NDB2V1
M28	IO101NDB2V2
M29	IO103NDB2V2
M30	IO119PDB3V0

FG896	
Pin Number	AGLE3000 Function
N1	IO276PDB7V0
N2	IO278PDB7V0
N3	IO280PDB7V0
N4	IO284PDB7V1
N5	IO279PDB7V0
N6	IO285NDB7V1
N7	IO287NDB7V1
N8	IO281NDB7V0
N9	IO281PDB7V0
N10	VCCIB7
N11	VCC
N12	GND
N13	GND
N14	GND
N15	GND
N16	GND
N17	GND
N18	GND
N19	GND
N20	VCC
N21	VCCIB2
N22	IO106NDB2V3
N23	IO106PDB2V3
N24	IO108PDB2V3
N25	IO108NDB2V3
N26	IO95NDB2V1
N27	IO99NDB2V2
N28	IO99PDB2V2
N29	IO107PDB2V3
N30	IO107NDB2V3
P1	IO276NDB7V0
P2	IO278NDB7V0
P3	IO280NDB7V0
P4	IO284NDB7V1
P5	IO279NDB7V0

FG896	
Pin Number	AGLE3000 Function
P6	GFC1/IO275PDB7V0
P7	GFC0/IO275NDB7V0
P8	IO277PDB7V0
P9	IO277NDB7V0
P10	VCCIB7
P11	VCC
P12	GND
P13	GND
P14	GND
P15	GND
P16	GND
P17	GND
P18	GND
P19	GND
P20	VCC
P21	VCCIB2
P22	GCC1/IO112PDB2V3
P23	IO110PDB2V3
P24	IO110NDB2V3
P25	IO109PPB2V3
P26	IO111NPB2V3
P27	IO105PDB2V2
P28	IO105NDB2V2
P29	GCC2/IO117PDB3V0
P30	IO117NDB3V0
R1	GFC2/IO270PDB6V4
R2	GFB1/IO274PPB7V0
R3	VCOMPLF
R4	GFA0/IO273NDB6V4
R5	GFB0/IO274NPB7V0
R6	IO271NDB6V4
R7	GFB2/IO271PDB6V4
R8	IO269PDB6V4
R9	IO269NDB6V4
R10	VCCIB7

FG896	
Pin Number	AGLE3000 Function
R11	VCC
R12	GND
R13	GND
R14	GND
R15	GND
R16	GND
R17	GND
R18	GND
R19	GND
R20	VCC
R21	VCCIB2
R22	GCC0/IO112NDB2V3
R23	GCB2/IO116PDB3V0
R24	IO118PDB3V0
R25	IO111PPB2V3
R26	IO122PPB3V1
R27	GCA0/IO114NPB3V0
R28	VCOMPLC
R29	GCB1/IO113PPB2V3
R30	IO115NPB3V0
T1	IO270NDB6V4
T2	VCCPLF
T3	GFA2/IO272PPB6V4
T4	GFA1/IO273PDB6V4
T5	IO272NPB6V4
T6	IO267NDB6V4
T7	IO267PDB6V4
T8	IO265PDB6V3
T9	IO263PDB6V3
T10	VCCIB6
T11	VCC
T12	GND
T13	GND
T14	GND
T15	GND

FG896	
Pin Number	AGLE3000 Function
T16	GND
T17	GND
T18	GND
T19	GND
T20	VCC
T21	VCCIB3
T22	IO109NPB2V3
T23	IO116NDB3V0
T24	IO118NDB3V0
T25	IO122NPB3V1
T26	GCA1/IO114PPB3V0
T27	GCB0/IO113NPB2V3
T28	GCA2/IO115PPB3V0
T29	VCCPLC
T30	IO121PDB3V0
U1	IO268PDB6V4
U2	IO264NDB6V3
U3	IO264PDB6V3
U4	IO258PDB6V3
U5	IO258NDB6V3
U6	IO257PPB6V2
U7	IO261PPB6V3
U8	IO265NDB6V3
U9	IO263NDB6V3
U10	VCCIB6
U11	VCC
U12	GND
U13	GND
U14	GND
U15	GND
U16	GND
U17	GND
U18	GND
U19	GND
U20	VCC

FG896	
Pin Number	AGLE3000 Function
U21	VCCIB3
U22	IO120PDB3V0
U23	IO128PDB3V1
U24	IO124PDB3V1
U25	IO124NDB3V1
U26	IO126PDB3V1
U27	IO129PDB3V1
U28	IO127PDB3V1
U29	IO125PDB3V1
U30	IO121NDB3V0
V1	IO268NDB6V4
V2	IO262PDB6V3
V3	IO260PDB6V3
V4	IO252PDB6V2
V5	IO257NPB6V2
V6	IO261NPB6V3
V7	IO255PDB6V2
V8	IO259PDB6V3
V9	IO259NDB6V3
V10	VCCIB6
V11	VCC
V12	GND
V13	GND
V14	GND
V15	GND
V16	GND
V17	GND
V18	GND
V19	GND
V20	VCC
V21	VCCIB3
V22	IO120NDB3V0
V23	IO128NDB3V1
V24	IO132PDB3V2
V25	IO130PPB3V2

FG896	
Pin Number	AGLE3000 Function
V26	IO126NDB3V1
V27	IO129NDB3V1
V28	IO127NDB3V1
V29	IO125NDB3V1
V30	IO123PDB3V1
W1	IO266NDB6V4
W2	IO262NDB6V3
W3	IO260NDB6V3
W4	IO252NDB6V2
W5	IO251NDB6V2
W6	IO251PDB6V2
W7	IO255NDB6V2
W8	IO249PPB6V1
W9	IO253PDB6V2
W10	VCCIB6
W11	VCC
W12	GND
W13	GND
W14	GND
W15	GND
W16	GND
W17	GND
W18	GND
W19	GND
W20	VCC
W21	VCCIB3
W22	IO134PDB3V2
W23	IO138PDB3V3
W24	IO132NDB3V2
W25	IO136NPB3V2
W26	IO130NPB3V2
W27	IO141PDB3V3
W28	IO135PDB3V2
W29	IO131PDB3V2
W30	IO123NDB3V1

FG896	
Pin Number	AGLE3000 Function
Y1	IO266PDB6V4
Y2	IO250PDB6V2
Y3	IO250NDB6V2
Y4	IO246PDB6V1
Y5	IO247NDB6V1
Y6	IO247PDB6V1
Y7	IO249NPB6V1
Y8	IO245PDB6V1
Y9	IO253NDB6V2
Y10	GEB0/IO235NPB6V0
Y11	VCC
Y12	VCC
Y13	VCC
Y14	VCC
Y15	VCC
Y16	VCC
Y17	VCC
Y18	VCC
Y19	VCC
Y20	VCC
Y21	IO142PPB3V3
Y22	IO134NDB3V2
Y23	IO138NDB3V3
Y24	IO140NDB3V3
Y25	IO140PDB3V3
Y26	IO136PPB3V2
Y27	IO141NDB3V3
Y28	IO135NDB3V2
Y29	IO131NDB3V2
Y30	IO133PDB3V2



## 5 – Datasheet Information

### List of Changes

The following table lists critical changes that were made in each revision of the IGLOOe datasheet.

Revision	Changes	Page
Revision 13 (December 2012)	The "IGLOOe Ordering Information" section has been updated to mention "Y" as "Blank" mentioning "Device Does Not Include License to Implement IP Based on the Cryptography Research, Inc. (CRI) Patent Portfolio" (SAR 43176). Also added the missing heading 'Supply Voltage' under V2.	III
	The note in <a href="#">Table 2-143 • IGLOOe CCC/PLL Specification</a> and <a href="#">Table 2-144 • IGLOOe CCC/PLL Specification</a> referring the reader to SmartGen was revised to refer instead to the online help associated with the core (SAR 42568).	2-91, 2-92
	Live at Power-Up (LAPU) has been replaced with 'Instant On'.	NA
Revision 12 (September 2012)	The "Security" section was modified to clarify that Microsemi does not support read-back of programmed data.	1-2
	Libero Integrated Design Environment (IDE) was changed to Libero System-on-Chip (SoC) throughout the document (SAR 40272).	N/A
Revision 11 (August 2012)	The drive strength, IOL, and IOH value for 3.3 V GTL and 2.5 V GTL was changed from 25 mA to 20 mA in the following tables (SAR 37180): <a href="#">Table 2-21 • Summary of Maximum and Minimum DC Input and Output Levels</a> , <a href="#">Table 2-25 • Summary of I/O Timing Characteristics—Software Default Settings</a> <a href="#">Table 2-26 • Summary of I/O Timing Characteristics—Software Default Settings</a> <a href="#">Table 2-28 • I/O Output Buffer Maximum Resistances1</a> <a href="#">Table 2-73 • Minimum and Maximum DC Input and Output Levels</a> <a href="#">Table 2-77 • Minimum and Maximum DC Input and Output Levels</a> Also added note stating "Output drive strength is below JEDEC specification." for Tables 2-25, 2-26, and 2-28. Additionally, the IOL and IOH values for 3.3 V GTL+ and 2.5 V GTL+ were corrected from 51 to 35 (for 3.3 V GTL+) and from 40 to 33 (for 2.5 V GTL+) in <a href="#">table Table 2-21</a> (SAR 39713).	2-20 2-25 2-26 2-28 2-51 2-53
	In <a href="#">Table 2-117 • Minimum and Maximum DC Input and Output Levels</a> , VIL and VIH were revised so that the maximum is 3.6 V for all listed values of VCCI (SAR 37183).	2-65
	The following sentence was removed from the "VMVx I/O Supply Voltage (quiet)" section in the "Pin Descriptions and Packaging" section: "Within the package, the VMV plane is decoupled from the simultaneous switching noise originating from the output buffer VCCI domain" and replaced with "Within the package, the VMV plane biases the input stage of the I/Os in the I/O banks" (SAR 38318). The datasheet mentions that "VMV pins must be connected to the corresponding VCCI pins" for an ESD enhancement.	3-1

Revision	Changes	Page
Revision 10 (April 2012)	In <a href="#">Table 2-2 • Recommended Operating Conditions 1</a> , VPUMP programming voltage for operation was changed from "0 to 3.45 V" to "0 to 3.6 V" (SAR 32256). Values for VCCPLL at 1.2–1.5 V DC core supply voltage were changed from "1.14 to 1.26 V" to "1.14 to 1.575 V" (SAR 34701).	2-2
	The tables in the "Quiescent Supply Current" section were updated with revised notes on IDD. <a href="#">Table 2-8 • Power Supply State per Mode</a> is new (SARs 34745, 36949).	2-7
	$t_{DOUT}$ was corrected to $t_{DIN}$ in <a href="#">Figure 2-4 • Input Buffer Timing Model and Delays (example)</a> (SAR 37105).	2-17
	"TBD" for 3.3 V LVCMOS Wide Range in <a href="#">Table 2-28 • I/O Output Buffer Maximum Resistances1</a> and <a href="#">Table 2-30 • I/O Short Currents IOSH/IOSL</a> was replaced by "Same as regular 3.3 V LVCMOS" (SAR 33855). Values were also added for 1.2 V LVCMOS and 1.2 V LVCMOS Wide Range.	2-28, 2-30
	The formulas in the table notes for <a href="#">Table 2-29 • I/O Weak Pull-Up/Pull-Down Resistances</a> were corrected (SAR 34753).	2-29
	IOSH and IOSL values were added to 3.3 V LVCMOS Wide Range <a href="#">Table 2-40 • Minimum and Maximum DC Input and Output Levels</a> , 1.2 V LVCMOS <a href="#">Table 2-64 • Minimum and Maximum DC Input and Output Levels</a> , and 1.2 V LVCMOS Wide Range <a href="#">Table 2-68 • Minimum and Maximum DC Input and Output Levels</a> (SAR 33855).	2-35, 2-47, 2-48
	<a href="#">Figure 2-48 • FIFO Read</a> and <a href="#">Figure 2-49 • FIFO Write</a> have been added (SAR 34844).	2-103
	Values for $F_{DDRIMAX}$ and $F_{DDOMAX}$ were added to the tables in the Input DDR " <a href="#">Timing Characteristics</a> " section and Output DDR " <a href="#">Timing Characteristics</a> " section (SAR 34802).	2-77,2- 81
	Minimum pulse width High and Low values were added to the tables in the " <a href="#">Global Tree Timing Characteristics</a> " section. The maximum frequency for global clock parameter was removed from these tables because a frequency on the global is only an indication of what the global network can do. There are other limiters such as the SRAM, I/Os, and PLL. SmartTime software should be used to determine the design frequency (SAR 36952).	2-89
Revision 9 (March 2012)	The " <a href="#">In-System Programming (ISP) and Security</a> " section and " <a href="#">Security</a> " section were revised to clarify that although no existing security measures can give an absolute guarantee, Microsemi FPGAs implement the best security available in the industry (SAR 34665).	I, 1-2
	The Y security option and Licensed DPA Logo were added to the " <a href="#">IGLOOe Ordering Information</a> " section. The trademarked Licensed DPA Logo identifies that a product is covered by a DPA counter-measures license from Cryptography Research (SAR 34725).	III
	The following sentence was removed from the " <a href="#">Advanced Architecture</a> " section: "In addition, extensive on-chip programming circuitry allows for rapid, single-voltage (3.3 V) programming of IGLOOe devices via an IEEE 1532 JTAG interface" (SAR 34685).	1-3
	The " <a href="#">Specifying I/O States During Programming</a> " section is new (SAR 34696).	1-7
	Values for VCCPLL at 1.5 V DC core supply voltage were changed from "1.4 to 1.6 V" to "1.425 to 1.575 V" in <a href="#">Table 2-2 • Recommended Operating Conditions 1</a> (SAR 32292).	2-2
	The reference to guidelines for global spines and VersaTile rows, given in the " <a href="#">Global Clock Contribution—PCLOCK</a> " section, was corrected to the " <a href="#">Spine Architecture</a> " section of the Global Resources chapter in the <i>IGLOOe FPGA Fabric User's Guide</i> (SAR 34731).	2-13

Revision	Changes	Page
Revision 9 (continued)	The example in the paragraph above <a href="#">Table 2-31 • Duration of Short Circuit Event before Failure</a> was revised to change the maximum temperature from 110°C to 100°C, with an example of six months instead of three months (SAR 32287).	2-31
	The notes regarding drive strength in the "Summary of I/O Timing Characteristics – Default I/O Software Settings" section, "3.3 V LVCMOS Wide Range" section and "1.2 V LVCMOS Wide Range" section tables were revised for clarification. They now state that the minimum drive strength for the default software configuration when run in wide range is $\pm 100 \mu\text{A}$ . The drive strength displayed in software is supported in normal range only. For a detailed I/V curve, refer to the IBIS models (SAR 34766).	2-23, 2-35, 2-48
	The AC Loading figures in the "Single-Ended I/O Characteristics" section were updated to match tables in the "Summary of I/O Timing Characteristics – Default I/O Software Settings" section (SAR 34886).	2-32
	The following sentence was deleted from the "2.5 V LVCMOS" section (SAR 34793): "It uses a 5 V-tolerant input buffer and push-pull output buffer."	2-38
	<a href="#">Table 2-143 • IGLOOe CCC/PLL Specification</a> and <a href="#">Table 2-144 • IGLOOe CCC/PLL Specification</a> were updated. A note was added to both tables indicating that when the CCC/PLL core is generated by Microsemi core generator software, not all delay values of the specified delay increments are available (SAR 34818).	2-91, 2-92
	The following figures were deleted. Reference was made to a new application note, <i>Simultaneous Read-Write Operations in Dual-Port SRAM for Flash-Based cSoCs and FPGAs</i> , which covers these cases in detail (SAR 34869). <a href="#">Figure 2-46 • Write Access after Write onto Same Address</a> <a href="#">Figure 2-47 • Read Access after Write onto Same Address</a> <a href="#">Figure 2-48 • Write Access after Read onto Same Address</a> The port names in the SRAM "Timing Waveforms", SRAM "Timing Characteristics" tables, <a href="#">Figure 2-50 • FIFO Reset</a> , and the FIFO "Timing Characteristics" tables were revised to ensure consistency with the software names (SAR 35749).	2-95, 2-98, 2-104, 2-106
	The "Pin Descriptions and Packaging" chapter is new (SAR 34768).	3-1
	Package names used in the "Package Pin Assignments" section were revised to match standards given in <i>Package Mechanical Drawings</i> (SAR 34768)	4-1
July 2010	The versioning system for datasheets has been changed. Datasheets are assigned a revision number that increments each time the datasheet is revised. The "IGLOOe Device Status" table on <a href="#">page II</a> indicates the status for each device in the device family.	N/A

Revision	Changes	Page
<b>Revision 8 (Nov 2009)</b>	The version changed to v2.0 for IGLOOe datasheet chapters, indicating the datasheet contains information based on final characterization.	N/A
Product Brief v2.0	The "Pro (Professional) I/O" section was revised to add "Hot-swappable and cold-sparing I/Os."	I
	The "Reprogrammable Flash Technology" section was revised to add "250 MHz (1.5 V systems) and 160 MHz (1.2 V systems) System Performance."	I
	Definitions of hot-swap and cold-sparing were added to the "Pro I/Os with Advanced I/O Standards" section.	1-7
DC and Switching Characteristics v2.0	3.3 V LVCMOS and 1.2 V LVCMOS Wide Range support was added to the datasheet. This affects all tables that contained 3.3 V LVCMOS and 1.2 V LVCMOS data.	N/A
	III and IIH input leakage current information was added to all "Minimum and Maximum DC Input and Output Levels" tables.	N/A
	Values for 1.2 V wide range DC core supply voltage were added to Table 2-2 • Recommended Operating Conditions 1. Table notes regarding 3.3 V wide range and the core voltage required for programming were added to the table.	2-2
	The data in Table 2-6 • Temperature and Voltage Derating Factors for Timing Delays (1.5 V DC core supply voltage) and Table 2-7 • Temperature and Voltage Derating Factors for Timing Delays (1.2 V DC core supply voltage) was revised.	2-6
	3.3 V LVCMOS wide range data was included in Table 2-13 • Summary of I/O Input Buffer Power (per pin) – Default I/O Software Settings and Table 2-14 • Summary of I/O Output Buffer Power (per pin) – Default I/O Software Settings1. Table notes were added in connection with this data.	2-9, 2-10
	The temperature was revised from 110°C to 100°C in Table 2-31 • Duration of Short Circuit Event before Failure and Table 2-33 • I/O Input Rise Time, Fall Time, and Related I/O Reliability*.	2-31, 2-31
	The tables in the "Overview of I/O Performance" section and "Detailed I/O DC Characteristics" section were revised to include 3.3 V LVCMOS and 1.2 V LVCMOS wide range.	2-20, 2-28
	Most tables were updated in the following sections, revising existing values and adding information for 3.3 V and 1.2 V wide range: "Single-Ended I/O Characteristics" "Voltage-Referenced I/O Characteristics" "Differential I/O Characteristics"	2-32, 2-51, 2-62
	The value for "Delay range in block: fixed delay" was revised in Table 2-143 • IGLOOe CCC/PLL Specification and Table 2-144 • IGLOOe CCC/PLL Specification.	2-91, 2-92
	The timing characteristics tables for RAM4K9 and RAM512X18 were updated, including renaming of the address collision parameters.	2-98 – 2-101
<b>Revision 7 (Apr 2009)</b>	The –F speed grade is no longer offered for IGLOOe devices and was removed from the documentation. The speed grade column and note regarding –F speed grade were removed from "IGLOOe Ordering Information". The "Speed Grade and Temperature Grade Matrix" section was removed.	III, IV
Product Brief v1.4 DC and Switching Characteristics Advance v0.4		

Revision	Changes	Page
<b>Revision 6 (Feb 2009)</b> Product Brief v1.3	The "Pro (Professional) I/O" section was revised to add two bullets regarding wide range power supply voltage support.	I
	3.0 V was added to the list of supported voltages in the "Pro I/Os with Advanced I/O Standards" section. The "Wide Range I/O Support" section is new.	1-7
<b>Revision 5 (Oct 2008)</b> Product Brief v1.2	The Quiescent Current values in <a href="#">Table 1 • IGLOOe Product Family</a> table were updated.	I
<b>Revision 4 (Jul 2008)</b> Product Brief v1.1 DC and Switching Characteristics Advance v0.3	As a result of the Libero IDE v8.4 release, Actel now offers a wide range of core voltage support. The document was updated to change 1.2 V / 1.5 V to 1.2 V to 1.5 V.	N/A
<b>Revision 3 (Jun 2008)</b> DC and Switching Characteristics Advance v0.2	Tables have been updated to reflect default values in the software. The default I/O capacitance is 5 pF. Tables have been updated to include the LVCMOS 1.2 V I/O set.  DDR Tables have two additional data points added to reflect both edges for Input DDR setup and hold time.  The power data table has been updated to match SmartPower data rather than simulation values.	N/A
	<a href="#">Table 2-144 • IGLOOe CCC/PLL Specification</a> was updated to add VMV to the VCCI parameter row and remove the word "output" from the parameter description for VCCI. Table note 3 was added.	2-92
	<a href="#">Table 2-2 • Recommended Operating Conditions 1</a> was updated to include the T <sub>J</sub> parameter. Table note 9 is new.	2-2
	In <a href="#">Table 2-3 • Flash Programming Limits – Retention, Storage, and Operating Temperature</a> <sup>1</sup> , the maximum operating junction temperature was changed from 110° to 100°.	2-3
	VMV was removed from <a href="#">Table 2-4 • Overshoot and Undershoot Limits 1, 3</a> . The title of the table was revised to remove "as measured on quiet I/Os." Table note 2 was revised to remove "estimated SSO density over cycles." Table note 3 was deleted.	2-3
	The "PLL Behavior at Brownout Condition" section is new.	2-4
	<a href="#">Figure 2-2 • V2 Devices – I/O State as a Function of VCCI and VCC Voltage Levels</a> is new.	2-5
	EQ 2 was updated. The temperature was changed to 100°C, and therefore the end result changed.	2-6
	The table notes for <a href="#">Table 2-9 • Quiescent Supply Current (IDD), IGLOOe Flash*Freeze Mode*</a> , <a href="#">Table 2-10 • Quiescent Supply Current (IDD) Characteristics, IGLOOe Sleep Mode*</a> , and <a href="#">Table 2-11 • Quiescent Supply Current (IDD) Characteristics, IGLOOe Shutdown Mode*</a> were updated to remove VMV and include PDC6 and PDC7. VCCI and VJTAG were removed from the statement about IDD in the table note for <a href="#">Table 2-11 • Quiescent Supply Current (IDD) Characteristics, IGLOOe Shutdown Mode*</a> .	2-7
	Note 2 of <a href="#">Table 2-12 • Quiescent Supply Current (IDD) Characteristics, No Flash*Freeze Mode</a> <sup>1</sup> was updated to include VCCPLL. Note 4 was updated to include PDC6 and PDC7.	2-8
Table note 3 was added to <a href="#">Table 2-13 • Summary of I/O Input Buffer Power (per pin) – Default I/O Software Settings</a> and referenced for 1.2 V LVCMOS.	2-9	

Revision	Changes	Page														
<b>Revision 3 (cont'd)</b>	Table 2-14 • Summary of I/O Output Buffer Power (per pin) – Default I/O Software Settings1 was updated to change PDC3 to PDC7. The table notes were updated to reflect that power was measured on VCCI. Table note 4 is new.	2-10														
	Table 2-16 • Different Components Contributing to the Static Power Consumption in IGLOO Devices and Table 2-18 • Different Components Contributing to the Static Power Consumption in IGLOO Devices were updated to add PDC6 and PDC7, and to change the definition for PDC5 to bank quiescent power.	2-11, 2-12														
	A table subtitle was added for Table 2-18 • Different Components Contributing to the Static Power Consumption in IGLOO Devices.	2-12														
	The "Total Static Power Consumption—PSTAT" section was updated to revise the calculation of P <sub>STAT</sub> , including PDC6 and PDC7.	2-13														
	Footnote 1 was updated to include information about P <sub>AC13</sub> . The PLL Contribution equation was changed from: P <sub>PLL</sub> = P <sub>AC13</sub> + P <sub>AC14</sub> * F <sub>CLKOUT</sub> to P <sub>PLL</sub> = P <sub>DC4</sub> + P <sub>AC13</sub> * F <sub>CLKOUT</sub> .	2-14														
	The "Timing Model" was updated to be consistent with the revised timing numbers.	2-16														
	In Table 2-22 • Summary of Maximum and Minimum DC Input Levels, T <sub>J</sub> was changed to T <sub>A</sub> in notes 1 and 2.	2-22														
	Table 2-22 • Summary of Maximum and Minimum DC Input Levels was updated to include a hysteresis value for 1.2 V LVCMOS (Schmitt trigger mode).	2-22														
	All AC Loading figures for single-ended I/O standards were changed from Datapaths at 35 pF to 5 pF.	N/A														
The "1.2 V LVCMOS (JESD8-12A)" section is new.	2-47															
<b>Revision 2 (Jun 2008)</b> Product Brief v1.0	The product brief section of the datasheet was divided into two sections and given a version number, starting at v1.0. The first section of the document includes features, benefits, ordering information, and temperature and speed grade offerings. The second section is a device family overview.	N/A														
<b>Revision 2 (cont'd)</b> Packaging v1.1	The naming conventions changed for the following pins in the "FG484" for the A3GLE600: <table border="0" style="margin-left: 20px;"> <tr> <td>Pin Number</td> <td>New Function Name</td> </tr> <tr> <td>J19</td> <td>IO45PPB2V1</td> </tr> <tr> <td>K20</td> <td>IO45NPB2V1</td> </tr> <tr> <td>M2</td> <td>IO114NPB6V1</td> </tr> <tr> <td>N1</td> <td>IO114PPB6V1</td> </tr> <tr> <td>N4</td> <td>GFC2/IO115PPB6V1</td> </tr> <tr> <td>P3</td> <td>IO115NPB6V1</td> </tr> </table>	Pin Number	New Function Name	J19	IO45PPB2V1	K20	IO45NPB2V1	M2	IO114NPB6V1	N1	IO114PPB6V1	N4	GFC2/IO115PPB6V1	P3	IO115NPB6V1	4-6
Pin Number	New Function Name															
J19	IO45PPB2V1															
K20	IO45NPB2V1															
M2	IO114NPB6V1															
N1	IO114PPB6V1															
N4	GFC2/IO115PPB6V1															
P3	IO115NPB6V1															
<b>Revision 1 (Mar 2008)</b> Product Brief rev. 1	The "Low Power" section was updated to change "1.2 V and 1.5 V Core Voltage" to "1.2 V and 1.5 V Core and I/O Voltage." The text "(from 25 μW)" was removed from "Low Power Active FPGA Operation."  1.2_V was added to the list of core and I/O voltages in the "Pro (Professional) I/O" and "Pro I/Os with Advanced I/O Standards" section sections.	I  I, 1-7														
<b>Revision 0 (Jan 2008)</b>	This document was previously in datasheet Advance v0.4. As a result of moving to the handbook format, Actel has restarted the version numbers. The new version number is 51700096-001-0.	N/A														

Revision	Changes	Page
Advance v0.4 (December 2007)	The <a href="#">Table 1 • IGLOOe Product Family</a> table was updated to change the maximum number of user I/Os for AGLE3000.	I
	The " <a href="#">IGLOOe FPGAs Package Sizes Dimensions</a> " table is new. Package dimensions were removed from the " <a href="#">I/Os Per Package<sup>1</sup></a> " table. The number of I/Os was updated for FG896.	II
	A note regarding marking information was added to the " <a href="#">IGLOOe Ordering Information</a> " table.	III
	Table 2-4 • IGLOOe CCC/PLL Specification and Table 2-5 • IGLOOe CCC/PLL Specification were updated.	2-18, 2-19
	The "During Flash*Freeze Mode" section was updated to include information about the output of the I/O to the FPGA core.	2-60
	Figure 2-38 • Flash*Freeze Mode Type 1 – Timing Diagram was updated to modify the LSICC signal.	2-56
	Table 2-32 • Flash*Freeze Pin Location in IGLOOe Family Packages (device-independent) was updated for the FG896 package.	2-64
	Figure 2-40 • Flash*Freeze Mode Type 2 – Timing Diagram was updated to modify the LSICC Signal.	2-58
	Information regarding calculation of the quiescent supply current was added to the "Quiescent Supply Current" section.	3-6
	Table 3-8 • Quiescent Supply Current (IDD), IGLOOe Flash*Freeze Mode† was updated.	3-6
	Table 3-9 • Quiescent Supply Current (IDD), IGLOOe Sleep Mode (VCC = 0 V)† was updated.	3-6
	Table 3-11 • Quiescent Supply Current, No IGLOOe Flash*Freeze Mode <sup>1</sup> was updated.	3-6
	Table 3-99 • Minimum and Maximum DC Input and Output Levels was updated.	3-51
	Table 3-136 • JTAG 1532 and Table 3-135 • JTAG 1532 were updated.	3-95
	The "484-Pin FBGA" table for AGLE3000 is new.	4-11
The "896-Pin FBGA" package and table for AGLE3000 is new.	4-16	
Advance v0.3 (September 2007)	Cortex-M1 device information was added to the <a href="#">Table 1 • IGLOOe Product Family</a> table, the " <a href="#">I/Os Per Package 1</a> " table, " <a href="#">IGLOOe Ordering Information</a> ", and " <a href="#">Temperature Grade Offerings</a> ".	I, II, III, IV
Advance v0.2	The words "ambient temperature" were added to the temperature range in the " <a href="#">IGLOOe Ordering Information</a> ", " <a href="#">Temperature Grade Offerings</a> ", and " <a href="#">Speed Grade and Temperature Grade Matrix</a> " sections.	III, IV
	The T <sub>J</sub> parameter in Table 3-2 • Recommended Operating Conditions was changed to T <sub>A</sub> , ambient temperature, and table notes 6–8 were added.	3-2

## Datasheet Categories

### **Categories**

In order to provide the latest information to designers, some datasheet parameters are published before data has been fully characterized from silicon devices. The data provided for a given device, as highlighted in the "IGLOOe Device Status" table, is designated as either "Product Brief," "Advance," "Preliminary," or "Production." The definitions of these categories are as follows:

#### **Product Brief**

The product brief is a summarized version of a datasheet (advance or production) and contains general product information. This document gives an overview of specific device and family information.

#### **Advance**

This version contains initial estimated information based on simulation, other products, devices, or speed grades. This information can be used as estimates, but not for production. This label only applies to the DC and Switching Characteristics chapter of the datasheet and will only be used when the data has not been fully characterized.

#### **Preliminary**

The datasheet contains information based on simulation and/or initial characterization. The information is believed to be correct, but changes are possible.

#### **Production**

This version contains information that is considered to be final.

### **Export Administration Regulations (EAR)**

The products described in this document are subject to the Export Administration Regulations (EAR). They could require an approved export license prior to export from the United States. An export includes release of product or disclosure of technology to a foreign national inside or outside the United States.

## Safety Critical, Life Support, and High-Reliability Applications Policy

The products described in this advance status document may not have completed the Microsemi qualification process. Products may be amended or enhanced during the product introduction and qualification process, resulting in changes in device functionality or performance. It is the responsibility of each customer to ensure the fitness of any product (but especially a new product) for a particular purpose, including appropriateness for safety-critical, life-support, and other high-reliability applications. Consult the Microsemi SoC Products Group Terms and Conditions for specific liability exclusions relating to life-support applications. A reliability report covering all of the SoC Products Group's products is available at [http://www.microsemi.com/soc/documents/ORT\\_Report.pdf](http://www.microsemi.com/soc/documents/ORT_Report.pdf). Microsemi also offers a variety of enhanced qualification and lot acceptance screening procedures. Contact your local sales office for additional reliability information.





**Microsemi Corporate Headquarters**  
One Enterprise, Aliso Viejo CA 92656 USA  
Within the USA: +1 (949) 380-6100  
Sales: +1 (949) 380-6136  
Fax: +1 (949) 215-4996

Microsemi Corporation (NASDAQ: MSCC) offers a comprehensive portfolio of semiconductor solutions for: aerospace, defense and security; enterprise and communications; and industrial and alternative energy markets. Products include high-performance, high-reliability analog and RF devices, mixed signal and RF integrated circuits, customizable SoCs, FPGAs, and complete subsystems. Microsemi is headquartered in Aliso Viejo, Calif. Learn more at [www.microsemi.com](http://www.microsemi.com).

© 2012 Microsemi Corporation. All rights reserved. Microsemi and the Microsemi logo are trademarks of Microsemi Corporation. All other trademarks and service marks are the property of their respective owners.