

THE INFORMATION CONTAINED HEREIN IS CONSIDERED "PROPRIETARY" TO BEL FUSE INC. AND SHALL NOT BE COPIED, REPRODUCED OR DISCLOSED WITHOUT THE WRITTEN APPROVAL OF BEL FUSE INC.

PRELIMINARY



LED1 POLARITY			LED2 POLARITY		
PIN 11	PIN 12	COLOR	PIN 13	PIN 14	COLOR
-	+	YELLOW	-	+	YELLOW
+	-	GREEN	+	-	GREEN

ELECTRICAL CHARACTERISTICS @ 25°C

URNS RATIO

TP1	1CT : 1CT ±3%
TP2	1CT : 1CT ±3%
TP3	1CT : 1CT ±3%
TP4	1CT : 1CT ±3%

□CL @ 100kHz/100mVRMS

8mA DC BIAS 350µH MIN

INSERTION LOSS

100KHz TO 100MHz -1.1 dB MAX

RETURN LOSS (MIN)

1MHz-30MHz -18 dB
30MHz-100MHz -12+20LOG(f/80MHz) dB

CM TO CM REJ

100KHz - 100MHz -35 dB TYP

CROSS TALK:

1MHz - 60MHz -35 dB MIN
60Hz - 100MHz -25 dB MIN

HIPOT (Isolation Voltage): 1500 Vrms

100% OF PRODUCTION TESTED TO COMPLY WITH

IEEE 802.3 ISOLATION REQUIREMENTS.

LED 1 AND LED 2

VF (FORWARD VOLTAGE)	IF=20mA	GREEN	2.2V TYP.
		YELLOW	2.1V TYP.
λD (DOMINANT WAVELENGTH)	IF=20mA	GREEN	565nm TYP.
		YELLOW	590nm TYP.

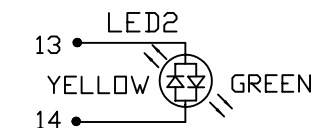
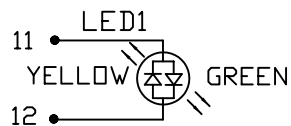

SCHEMATIC

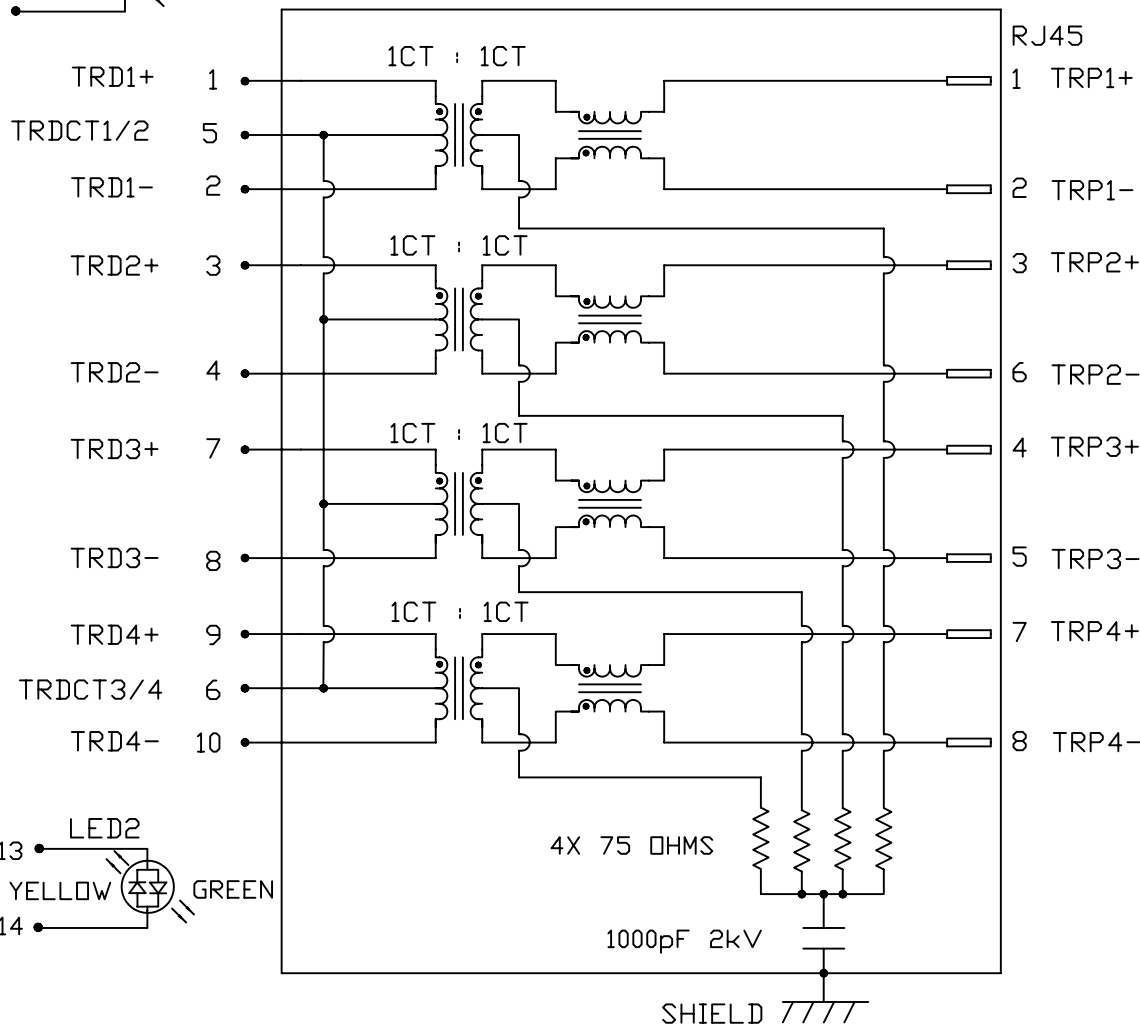

ORIGINATED BY	DATE
CHOW WANGCHUNG	09-15-09
DRAWN BY	DATE
LEE WEIDE	09-15-09

TITLE
Gigabit MagJack® (WITH LED) PATENTED

PART NO. / DRAWING NO.
SI-61034-F
FILE NAME
SI-61034-F_PA.DWG

STANDARD DIM.	[] METRIC DIM. AS REFERENCE
TOL. IN INCH	UNIT : INCH [mm]
.X	REV. : PA
.XX	SCALE : N/A
.XXX	SIZE : A4
	PAGE : 2



THE INFORMATION CONTAINED HEREIN IS CONSIDERED "PROPRIETARY" TO BEL FUSE INC. AND SHALL NOT BE COPIED, REPRODUCED OR DISCLOSED WITHOUT THE WRITTEN APPROVAL OF BEL FUSE INC.



PRELIMINARY

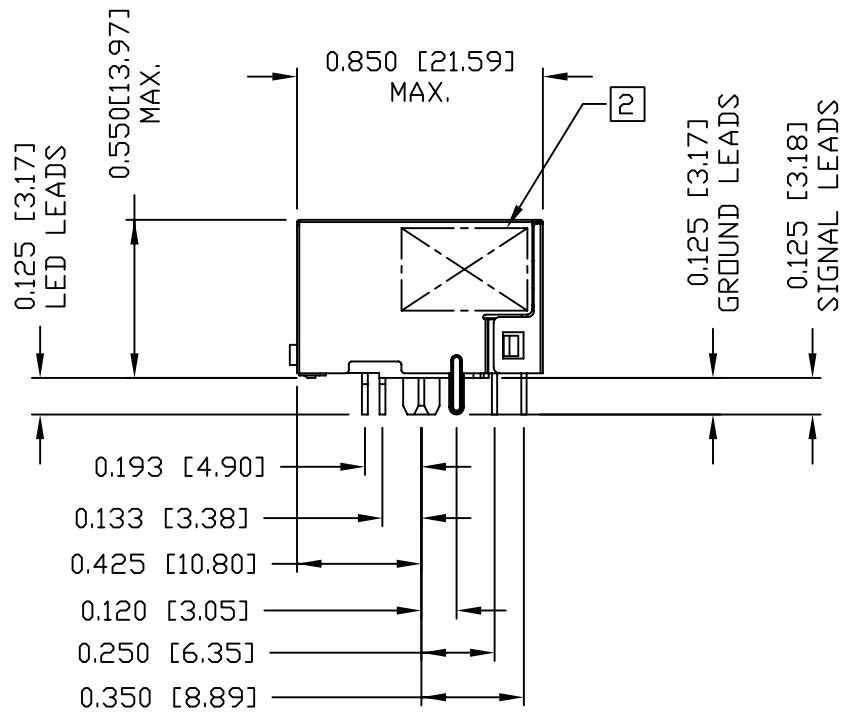
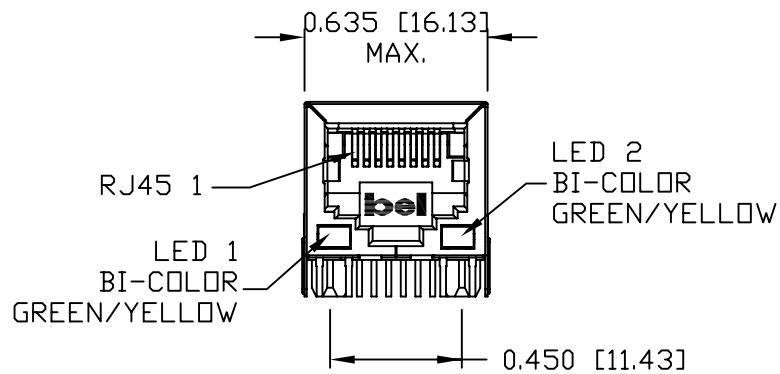
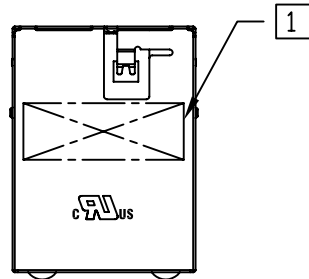

NOTES:

- PLASTIC HOUSING: THERMOPLASTIC PBT
FLAMMABILITY RATING UL 94V-0
- CONTACTS PLATING: 50 MICRO-INCH HARD GOLD PLATING
- PINS: TIN-COATED COPPER WIRE, DIA 0.018 INCH.
- METAL SHIELD: NICKEL PLATED ON COPPER ALLOY.
(ALL GROUND LEADS ARE SOLDER DIPPED)

- 1 MARK PART WITH MFG PART NUMBER(SI-61034-F), DATE CODE AND PATENTED.
- 2 MARK PART WITH MFG LOGO, MFG NAME.
- 3. JACK CAVITY CONFORMS TO FCC RULES AND REGULATIONS
- 4. RoHS COMPLIANCE, PER EU DIRECTIVE 2002/95/EC.
- UL** UL RECOGNIZED - FILE #E132408.
- 5. THE PRODUCT IS PATENTED, THE PATENT NUMBER IS U.S. PAT. 5,736,910.

ORIGINATED BY LIU QIN	DATE 09-15-09	TITLE Gigabit MagJack® (WITH LED) PATENTED	PART NO. / DRAWING NO. SI-61034-F	STANDARD DIM. TOL. IN INCH		[] METRIC DIM. AS REFERENCE		REV. : PA	PAGE : 3
				.X		UNIT : INCH [mm]	SCALE : N/A		
DRAWN BY XIAN JIAXIN	DATE 09-15-09		FILE NAME SI-61034-F_PA.DWG	.XX					
				.XXX	±0.010				



THE INFORMATION CONTAINED HEREIN IS CONSIDERED "PROPRIETARY" TO BEL FUSE INC. AND SHALL NOT BE COPIED, REPRODUCED OR DISCLOSED WITHOUT THE WRITTEN APPROVAL OF BEL FUSE INC.

RoHS
2002/95/EC



PRELIMINARY

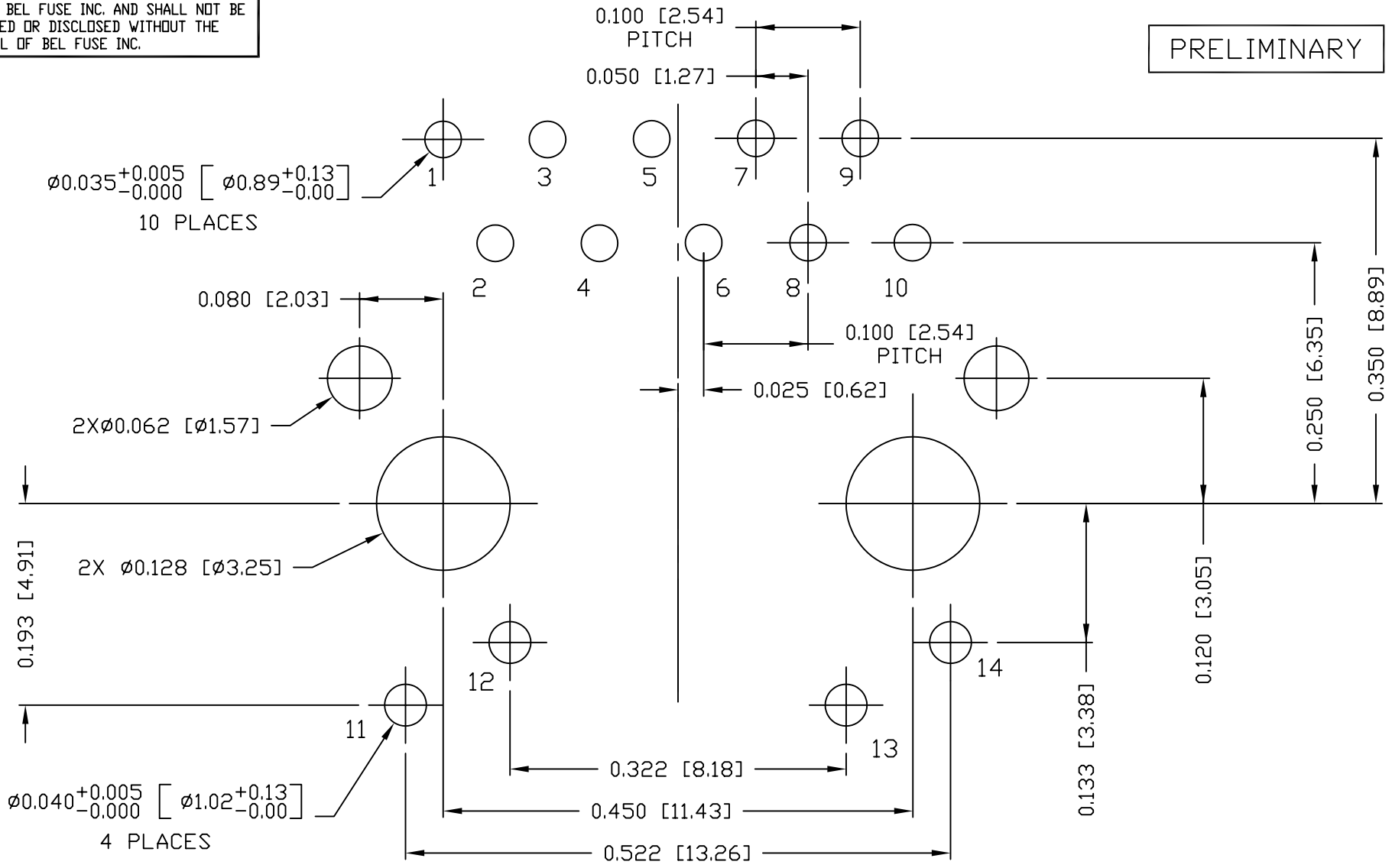

RECOMMENDED PCB FOOTPRINT
COMPONENT SIDE VIEW

ORIGINATED BY LIU QIN	DATE 09-15-09	TITLE Gigabit MagJack® (WITH LED) PATENTED	PART NO. / DRAWING NO. SI-61034-F		STANDARD DIM. TOL. IN INCH		[] METRIC DIM. AS REFERENCE	
	DRAWN BY XIAN JIAXIN		DATE 09-15-09	FILE NAME SI-61034-F_PA.DWG	.X .XX .XXX	±0.004	UNIT : INCH [mm] SCALE : N/A	REV. : PA SIZE : A4 PAGE : 4



THE INFORMATION CONTAINED HEREIN IS CONSIDERED "PROPRIETARY" TO BEL FUSE INC. AND SHALL NOT BE COPIED, REPRODUCED OR DISCLOSED WITHOUT THE WRITTEN APPROVAL OF BEL FUSE INC.



PRELIMINARY

SUGGESTED PANEL OPENING

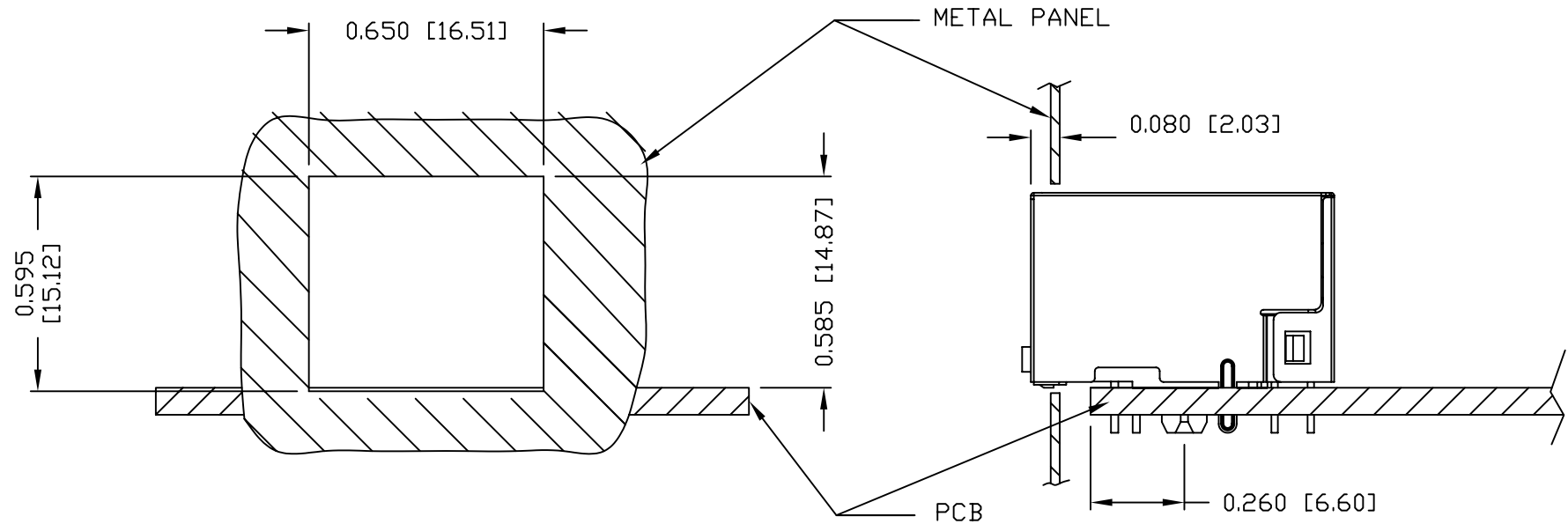

NOTES:

THE DISTANCE OF PANEL INSIDE SURFACE RELATIVE TO FRONT SURFACE OF PART IS ONLY A SUGGESTION. IN CASE THIS DISTANCE IS DIFFERENT, THE REQUIRED PANEL OPENING DIMENSIONS CHANGE ACCORDINGLY.

PACKING INFORMATION

PACKING TRAY : 0200-9999-Q7 (TOP)
0200-9999-Q8 (BOTTOM)

PACKING QUANTITY : 80 PCS FINISHED GOODS PER TRAY
10 TRAYS (800 PCS FINISHED GOODS) PER CARTON BOX

NOTE : CARDBOARDS ARE PLACED BETWEEN LAYERS OF PACKING TRAY INSIDE CARTON BOX
(INCLUDE THE UPPERMOST AND LOWERMOST TRAY)

ORIGINATED BY LIU QIN	DATE 09-15-09	TITLE Gigabit MagJack® (WITH LED) PATENTED	PART NO. / DRAWING NO. SI-61034-F	STANDARD DIM. TOL. IN INCH .X .XX .XXX ±0.004	[] METRIC DIM. AS REFERENCE		
	DRAWN BY XIAN JIAXIN		DATE 09-15-09		FILE NAME SI-61034-F_PA.DWG	UNIT : INCH [mm]	REV. : PA
					SCALE : N/A	SIZE : A4	
						PAGE : 5	