

TLV4976-2K

Value Optimized Hall Effect Switch with Current Interface for Industrial and Consumer Applications

Data Sheet

Rev. 1.1, 2010-08-02

Edition 2010-08-02

**Published by
Infineon Technologies AG
81726 Munich, Germany**

**© 2010 Infineon Technologies AG
All Rights Reserved.**

Legal Disclaimer

The information given in this document shall in no event be regarded as a guarantee of conditions or characteristics. With respect to any examples or hints given herein, any typical values stated herein and/or any information regarding the application of the device, Infineon Technologies hereby disclaims any and all warranties and liabilities of any kind, including without limitation, warranties of non-infringement of intellectual property rights of any third party.

Information

For further information on technology, delivery terms and conditions and prices, please contact the nearest Infineon Technologies Office (www.infineon.com).

Warnings

Due to technical requirements, components may contain dangerous substances. For information on the types in question, please contact the nearest Infineon Technologies Office.

Infineon Technologies components may be used in life-support devices or systems only with the express written approval of Infineon Technologies, if a failure of such components can reasonably be expected to cause the failure of that life-support device or system or to affect the safety or effectiveness of that device or system. Life support devices or systems are intended to be implanted in the human body or to support and/or maintain and sustain and/or protect human life. If they fail, it is reasonable to assume that the health of the user or other persons may be endangered.

Value Optimized Hall Effect Latches for Industrial and Consumer Applications**Revision History: 2010-08-02, Rev. 1.1****Previous Revisions: 1.0**

Page	Subjects (major changes since last revision)
all	change to halogen free package

We Listen to Your Comments

Any information within this document that you feel is wrong, unclear or missing at all?
Your feedback will help us to continuously improve the quality of this document.
Please send your proposal (including a reference to this document) to:

sensors@infineon.com



Table of Contents

1	Product Description	6
1.1	Overview	6
1.2	Features	6
1.3	Target Applications	6
2	Functional Description	7
2.1	General	7
2.2	Pin Configuration (top view)	7
2.3	Pin Description	7
2.4	Block Diagram	8
2.5	Functional Block Description	8
3	Specification	10
3.1	Application Circuit	10
3.2	Absolute Maximum Ratings	11
3.3	Operating Range	11
3.4	Electrical and Magnetic Characteristics	11
4	Package Information	14
4.1	Package Outline PG-SC59-3-5	14
4.2	Footprint	15
4.3	Distance between Chip and Package	16
4.4	Package Marking	16



1 Product Description

1.1 Overview

The TLV4976-2K is a high precision unipolar Hall switch with a two wire, 6mA/14mA current interface in a SMD package. A chopped measurement principle provides high stability switching thresholds for operating temperatures between -40°C and 85°C.



1.2 Features

- 3.0V to 18V supply voltage operation
- High sensitivity and high stability of the magnetic switching points
- High resistance to mechanical stress by Active Error Compensation
- Reverse battery protection (-18V)
- Superior temperature stability
- Low jitter (typ. 1µs)
- High ESD performance (± 4kV HBM)
- Digital output signal with current modulation 6 / 14mA
- Unipolar version
- SMD package SC59 (SOT23 compatible), lead free and halogen free
- For industrial and consumer applications, not qualified for automotive applications

1.3 Target Applications

The sensor targets all applications where a high precision unipolar magnetic switch is required (e.g. position sensing). Due to the current interface the number of wires required in the application is minimized thus saving costs and increasing reliability. This is specially helpful in all applications where the microcontroller is not on the same PCB as the Hall switch but in some distance.

Product Name	Product Type	Ordering Code	Package
TLV4976-2K	Hall Effect Switch	SP000803734	PG-SC59-3-5

2 Functional Description

2.1 General

The TLV4976-2K is an integrated circuit Hall-effect sensor designed specifically for highly accurate applications. Precise magnetic switching thresholds and high temperature stability are achieved by active error compensation circuits and chopper techniques on the chip. The IC has a current interface with a 6mA / 14mA output. A magnetic south pole (positive field) with strength above B_{rp} turns the output to low (6mA) and a magnetic field with strength below B_{op} turns it to high (14mA).

2.2 Pin Configuration (top view)

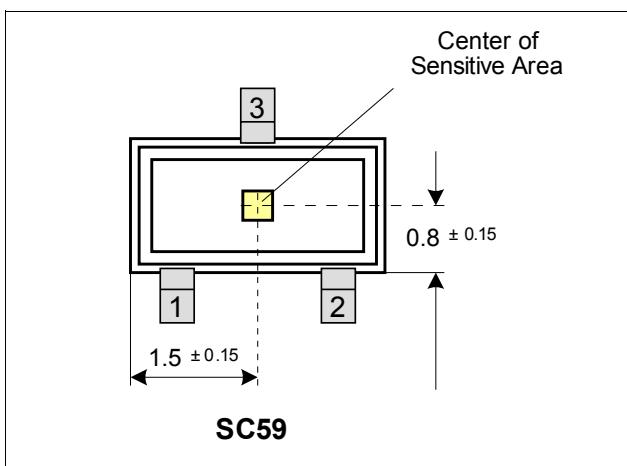

Figure 1 Pin Configuration and Center of Sensitive Area

2.3 Pin Description

Table 1 Pin Description

Pin No.	Symbol	Function	Comment
1	V_S	Supply voltage	
2	N.C.	No internal connection	
3	GND	Ground	

2.4 Block Diagram

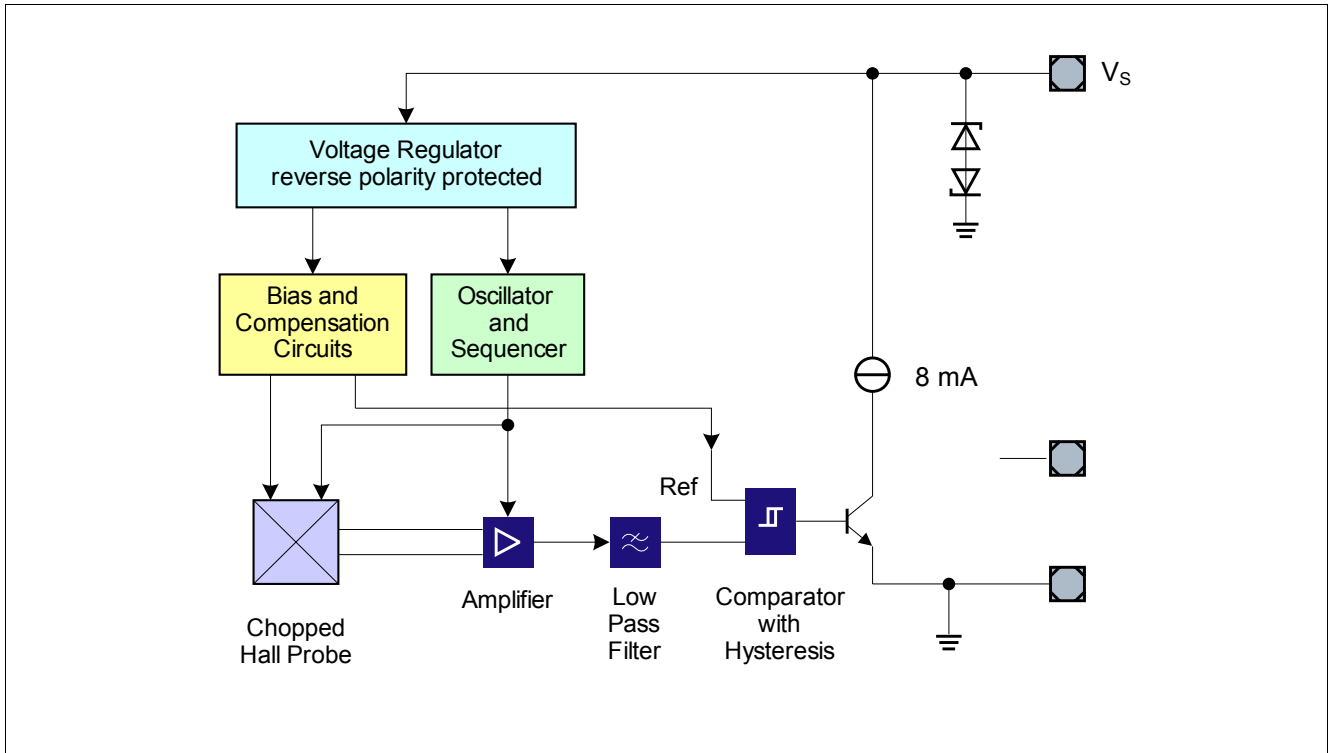

Figure 2 Functional Block Diagram

2.5 Functional Block Description

The chopped Hall IC Switch comprises a Hall probe, bias generator, compensation circuits, oscillator and output transistor.

The bias generator provides currents for the Hall probe and the active circuits. Compensation circuits stabilize the temperature behavior and reduce technology variations.

The Active Error Compensation rejects offsets in signal stages and the influence of mechanical stress to the Hall probe caused by molding and soldering processes and other thermal stresses in the package.

This chopper technique together with the threshold generator and the comparator ensure high accurate magnetic switching points.

The current consumption depends on the switching status.

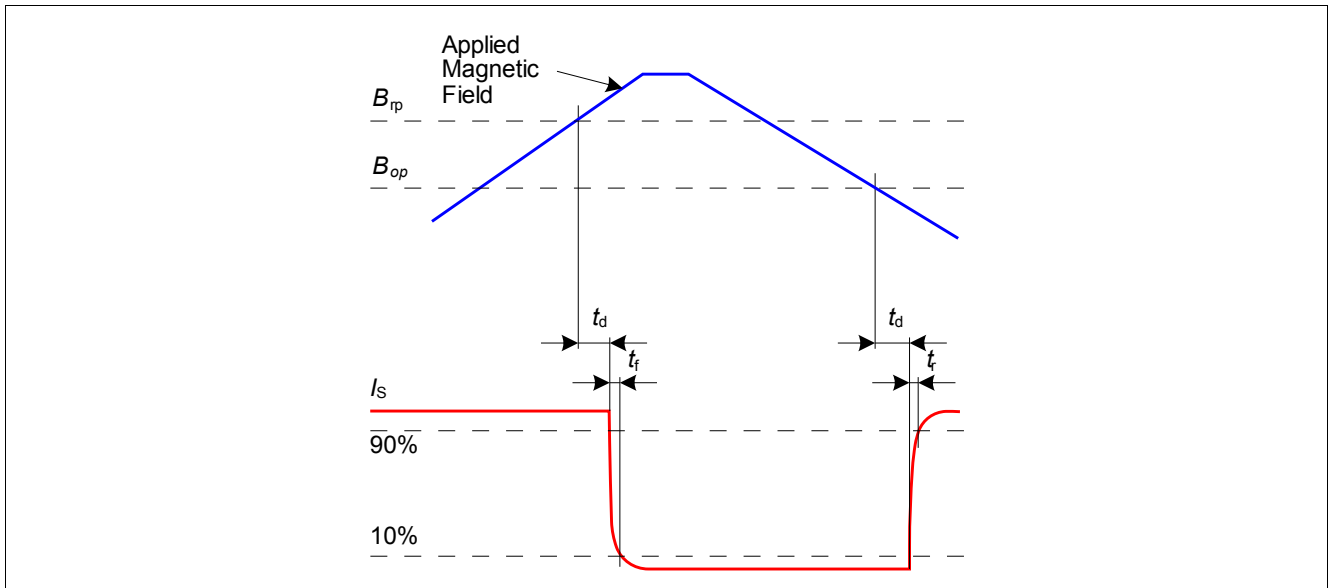

Figure 3 Timing Diagram

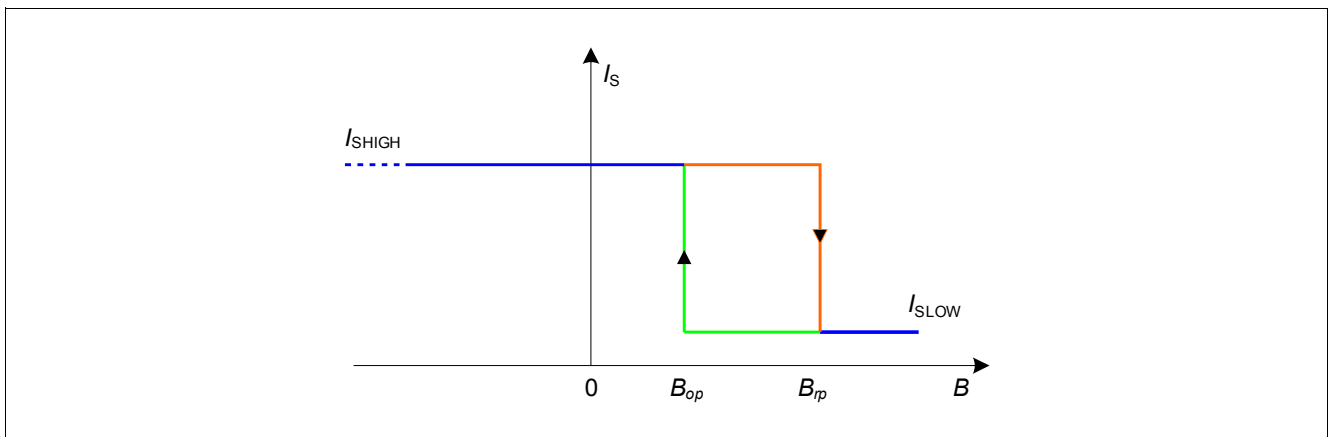

Figure 4 Output Signal

3 Specification

3.1 Application Circuit

The advantage of the current interface is, that only two wires are necessary to connect the sensor.

At least one series resistor is required to convert the two output states of the Hall sensor from current consumption to a voltage information.

A typical value for R_L is 100Ω . This gives a typical signal voltage level $V_{SIG} = 0.8V$ in the *Off* state and $1.4V$ in the *On* state.

If the sensor is operated in an application environment with disturbances on the supply line, an additional series resistor R_S is recommended. The maximum value for the series resistor R_S can be calculated using the following formula:

$$R_{Smax} = \frac{V_{Supplymin} - V_{Smin}}{I_{Shighmax}} - R_L$$

V_{S_min} is the minimal supply voltage which might occur due to disturbances on the supply line V_S .

Example: $V_{Supplymin} = 6V$; $V_{Smin} = 3V$; $R_L = 100\Omega$; $I_{Shighmax} = 17mA$: $R_{Smax} = 76.5\Omega$

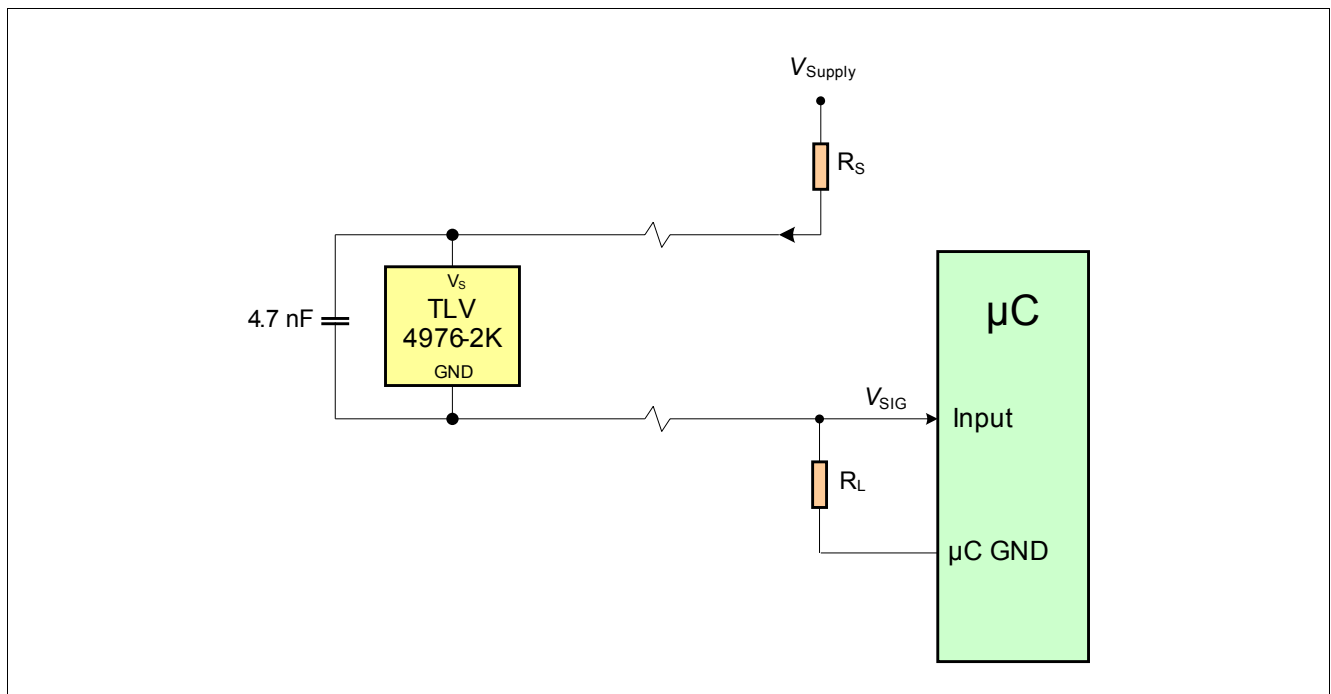

Figure 5 Application Circuit

3.2 Absolute Maximum Ratings

Table 2 Absolute Maximum Rating Parameters

Parameter	Symbol	Limit Values		Unit	Note / Test Condition
		Min.	Max.		
Maximum Ambient Temperature	T_A	-40	125	°C	
Maximum Junction Temperature	T_J	-40	150	°C	
Supply Voltage	V_S	-18	18	V	
Supply current through protection device	I_S	-50	+50	mA	
Storage temperature	T_S	-40	150	°C	
Magnetic flux density	B	–	unlimited	mT	
ESD robustness HBM ¹⁾	$V_{ESD,HBM}$		4	kV	R = 1.5kΩ, C = 100pF $T_A = 25^\circ\text{C}$

1) Human Body Model (HBM) tests according to: EOS/ESD Association Standard S5.1-1993 and Mil. Std. 883D method 3015.7

Attention: Stresses above the max. values listed here may cause permanent damage to the device. Exposure to absolute maximum rating conditions for extended periods may affect device reliability. Maximum ratings are absolute ratings; exceeding only one of these values may cause irreversible damage to the integrated circuit.

3.3 Operating Range

The following operating conditions must not be exceeded in order to ensure correct operation of the Hall Effect Switch.

All parameters specified in the following sections refer to these operating conditions unless otherwise mentioned.

Table 3 Operating Conditions Parameters

Parameter	Symbol	Values			Unit	Note / Test Condition
		Min.	Typ.	Max.		
Supply voltage	V_S	3		18	V	
Junction temperature	T_j	- 40		85	°C	

3.4 Electrical and Magnetic Characteristics

Product characteristics involve the spread of values guaranteed within the specified voltage and ambient temperature range. Typical characteristics are the median of the production.

Table 4 General Electrical Characteristics¹⁾

Parameter	Symbol	Values			Unit	Note / Test Condition
		Min.	Typ.	Max.		
Supply current low	I_{SLOW}	5	6	7	mA	$B > B_{RP}$ $V_S = 3V \dots 18V$
Supply current high	I_{SHIGH}	12	14	17	mA	$B < B_{OP}$ $V_S = 3V \dots 18V$

Table 4 General Electrical Characteristics¹⁾ (cont'd)

Parameter	Symbol	Values			Unit	Note / Test Condition
		Min.	Typ.	Max.		
Reverse current	I_{SR}		–	0.2	mA	$V_S = -18V$
Output fall time	t_f	–	0.4	1.6	μs	$R_S = 100\Omega$
Output rise time	t_r	–	0.4	1.6	μs	
Chopper frequency	f_{OSC}	–	320		kHz	
Switching freq.	f_{SW}		–	15 ²⁾	kHz	
Delay time ³⁾	t_d	–	13		μs	
Output jitter ⁴⁾	t_{QJ}	–	1	–	μs_{RMS}	Typical value for square wave signal 1kHz
Power-on time ⁵⁾	t_{PON}	–	13	–	μs	$V_S \geq 3.0V$
Thermal resistance ⁶⁾	R_{thJA}	–	100	–	K/W	PG-SC59-3-5

- 1) over operating range, unless otherwise specified. Typical values correspond to $V_S = 12V$ and $T_A = 25^\circ C$
- 2) To operate the sensor at the max. switching frequency, the value of the magnetic signal amplitude must be 1.4 times higher than for static fields. This is due to the -3dB corner frequency of the low pass filter in the signal path
- 3) Systematic delay between magnetic threshold reached and output switching
- 4) Jitter is the unpredictable deviation of the output switching delay
- 5) Time from applying $V_S \geq 3.0V$ to the sensor until the output state is valid
- 6) Thermal resistance from junction to ambient

Calculation of the ambient temperature:

e.g. for $V_S = 12.0V$, $R_S = 100\Omega$, $I_{SHIGHtyp} = 14mA$:

Power Dissipation: $P_{DIS} = 148.4mW$.

In $T_A = T_j - (R_{thJA} \times P_{DIS}) = 175^\circ C - (100K/W \times 0.15W)$

Resulting max. ambient temperature: $T_A = 160^\circ C$

Table 5 Magnetic Characteristics¹⁾

Parameter	Symbol	T (°C)	Values			Unit	Note / Test Condition
			Min.	Typ.	Max.		
Operating point	B_{OP}	-40	0.53	2.9	5.1	mT	
		25	0.5	2.7	4.8		
		85	0.47	2.5	4.5		
Release point	B_{RP}	-40	2.1	4.8	6.4	mT	
		25	2.0	4.5	6.0		
		85	1.9	4.2	5.6		
Hysteresis	B_{HYS}		0.5	1.8	3.0	mT	for T = 25°C
Temperature compensation of magnetic thresholds	T_C		-	-1000	-	ppm/K	
Repeatability of magnetic thresholds ²⁾	B_{REP}		-	40	-	μT_{RMS}	Typ. value for $\Delta B / \Delta t > 12 mT/ms$

- 1) over operating range, unless otherwise specified. Typical values correspond to $V_S = 12 V$.
- 2) BREP is equivalent to the noise constant

Field Direction Definition

Positive magnetic fields are defined with the south pole of the magnet to the branded side of package.

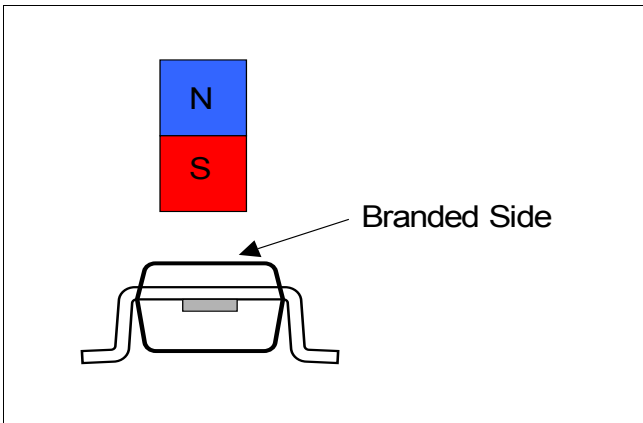

Figure 6 Definition of magnetic field direction

4 Package Information

4.1 Package Outline PG-SC59-3-5

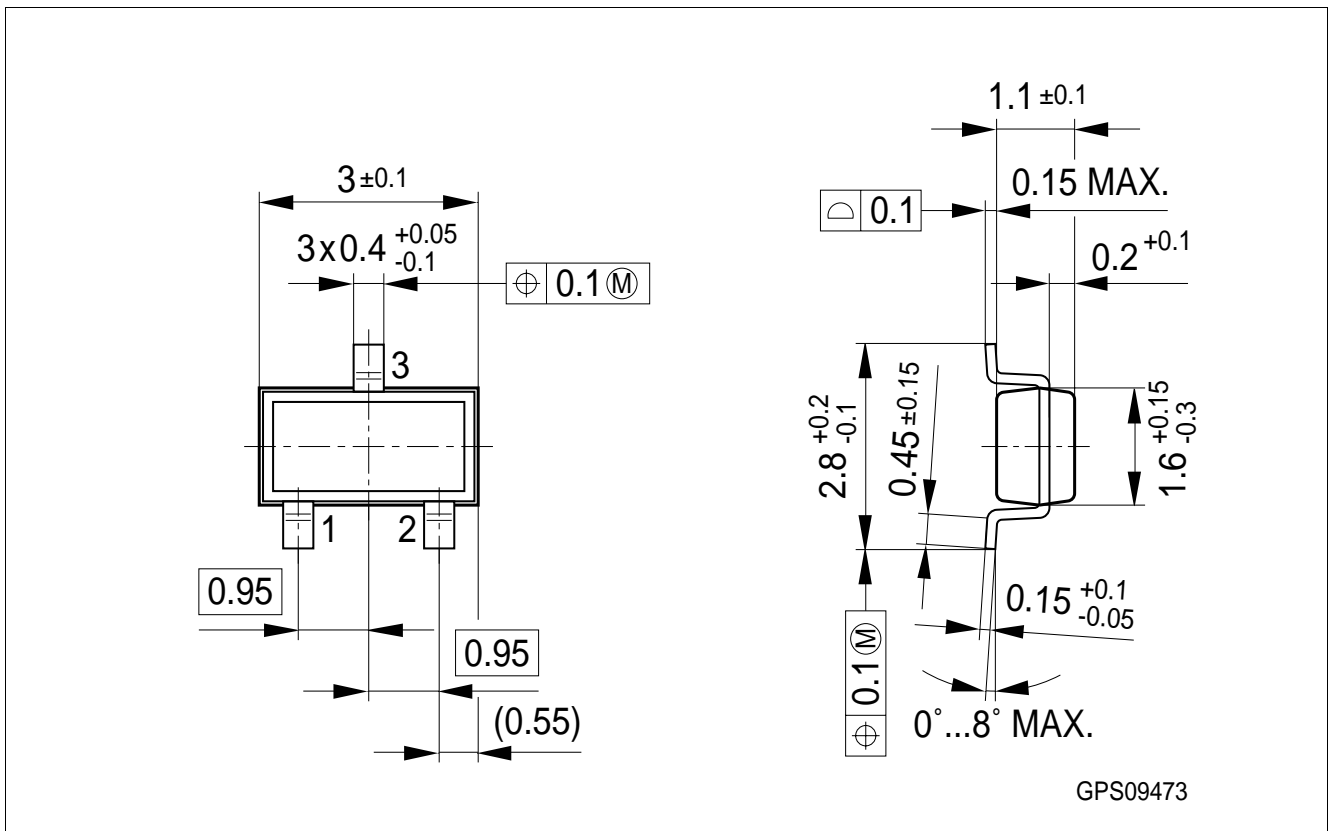

Figure 7 PG-SC59-3-5 Package Outline (All dimensions in mm)

4.2 Footprint

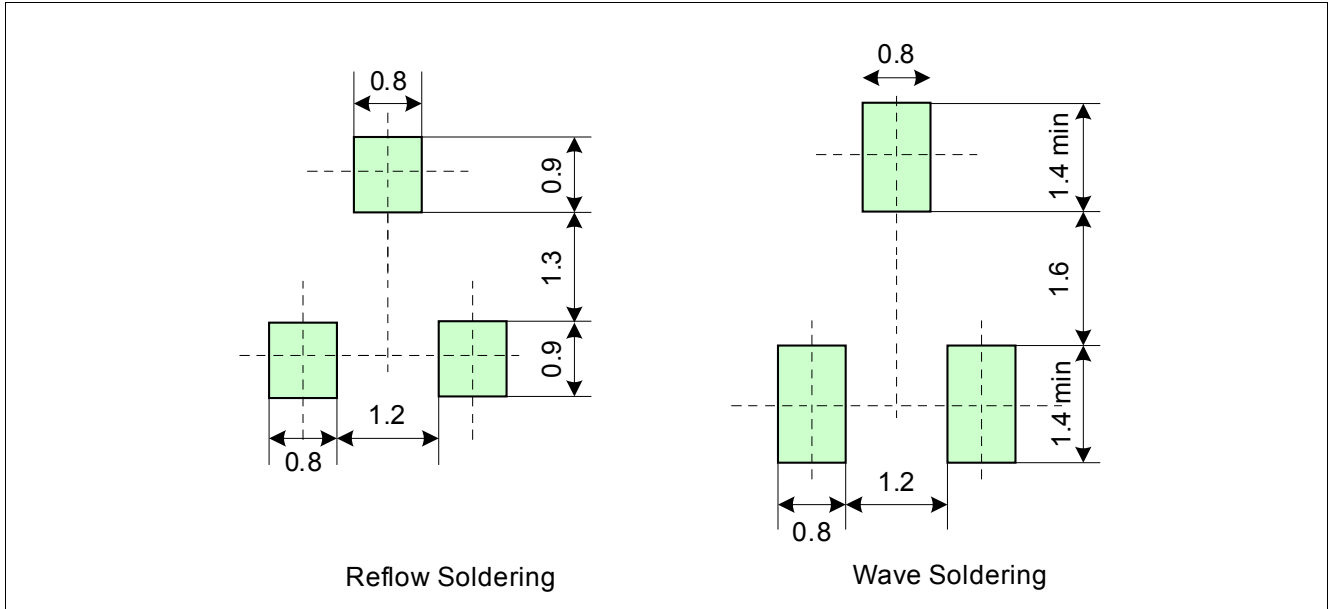

Figure 8 Footprint PG-SC59-3-5

4.3 Distance between Chip and Package

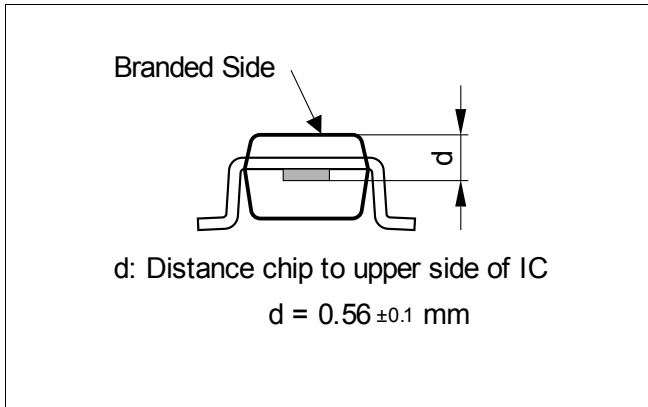

Figure 9 Distance between chip and package

4.4 Package Marking

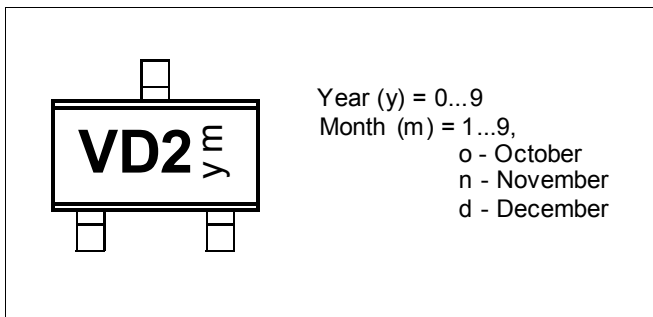

Figure 10 Marking of TLV4976-2K

www.infineon.com