



THE INFORMATION CONTAINED HEREIN IS CONSIDERED "PROPRIETARY" TO BEL FUSE INC. AND SHALL NOT BE COPIED, REPRODUCED OR DISCLOSED WITHOUT THE WRITTEN APPROVAL OF BEL FUSE INC.

RoHS



ELECTRICAL CHARACTERISTICS @ 25° C

- 1.0 TURNS RATIO: (P1-P3) : (J1-J2) : 1CT : 1CT ± 2%  
(P4-P5) : (J3-J6) : 1CT : 1CT ± 2%
- 2.0 DC RESISTANCE: (P1-P3); (P4-P5) : 1.2 OHMS  
(J1-J2); (J3-J6) : 0.8 OHMS
- 3.0 INDUCTANCE: (P1-P3) : 350uH MIN. @ 0.1V, 100KHz, 12mA DC Bias  
(P4-P5) : 350uH MIN. @ 0.1V, 100KHz, 12mA DC Bias
- 4.0 RETURN LOSS: (P1-P3)=100 OHMS REF. AND (P4-P5)=100 OHM REF.  
1MHz TO 30MHz : 16dB MIN.  
60MHz TO 80MHz : 10dB MIN.
- 5.0 INSERTION LOSS: RS & RL =100 ohms  
1MHz TO 100MHz : 1.5 dB MAX
- 6.0 CROSS TALK: 1MHz - 100 MHz : 30 dB MIN.
- 7.0 DIELECTRIC WITHSTAND: (P1-P3) TO (J1-J2) : 2000 Vrms  
(P4-P5) TO (J3-J6) : 2000 Vrms
- 8.0 BALANCED DC LINE CURRENT: USED PAIRS : 700mA MAX  
UNUSED PAIRS : 700mA MAX
- 9.0 OPERATING TEMPERATURE: : -40 to 85° C

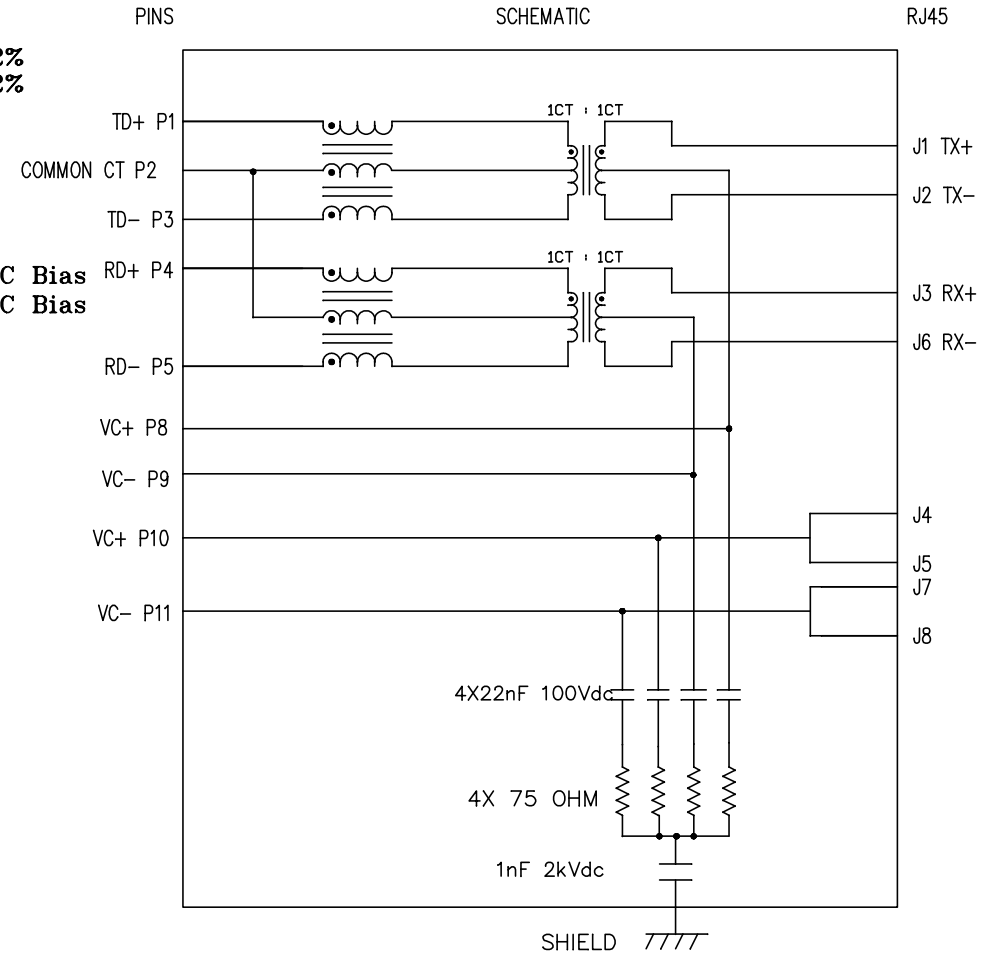

ORIGINATED BY	DATE	TITLE
Zeng Xiaochun	2012-04-18	<b>MagJack®</b> 10/100BT, PoEP TAB UP, SHIELDED PATENTED
DRAWN BY	DATE	
Duan Jun	2012-04-18	

PART NO. / DRAWING NO.	STANDARD DIM.
SI-52007-F	TOL. IN INCH
FILE NAME	
SI-52007-F.DWG	

[ ] METRIC DIM. AS REFERENCE
UNIT : INCH [mm]
SCALE : N/A
REV. : 03
SIZE : A4
PAGE : 2



THE INFORMATION CONTAINED HEREIN IS CONSIDERED "PROPRIETARY" TO BEL FUSE INC. AND SHALL NOT BE COPIED, REPRODUCED OR DISCLOSED WITHOUT THE WRITTEN APPROVAL OF BEL FUSE INC.

RoHS



STANDARD LED	WAVELENGTH	Forward V (MAX)	* (TYP)
YELLOW	590 nm	2.5 V	2.1 V
GREEN	565 nm	2.5 V	2.2 V

\* WITH A FORWARD CURRENT OF 20 mA (TYP)

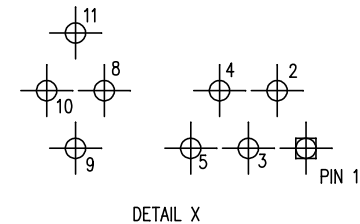
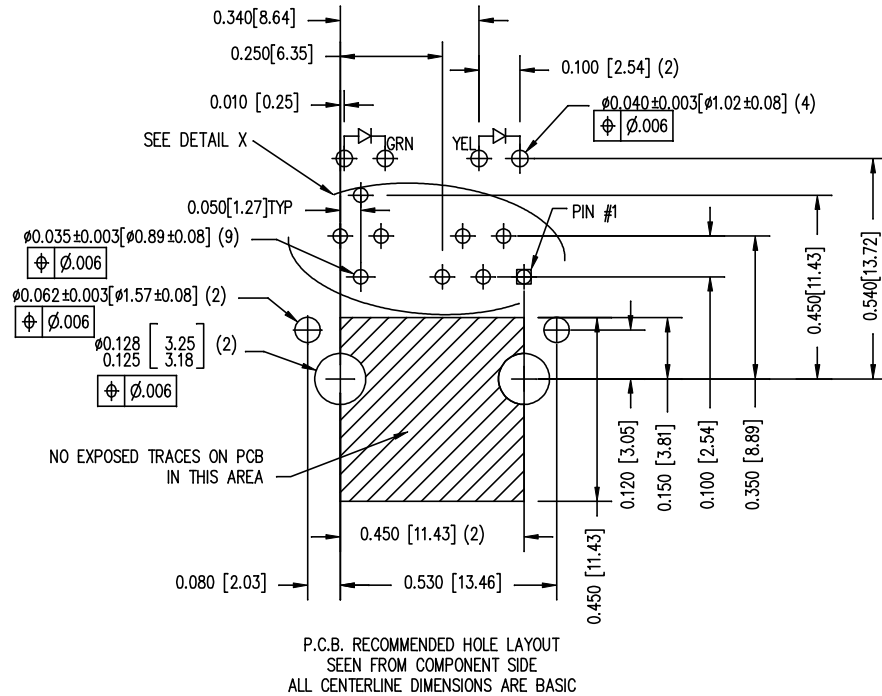
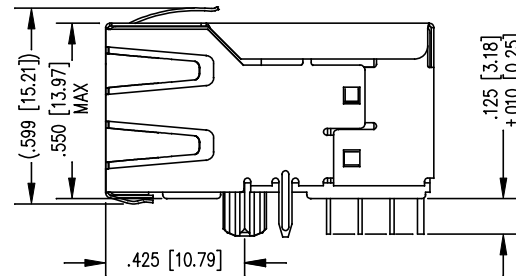
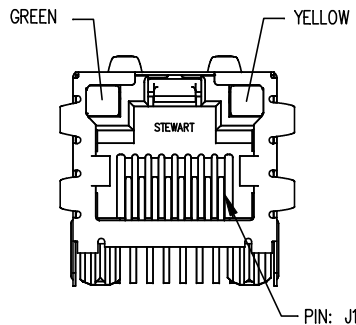
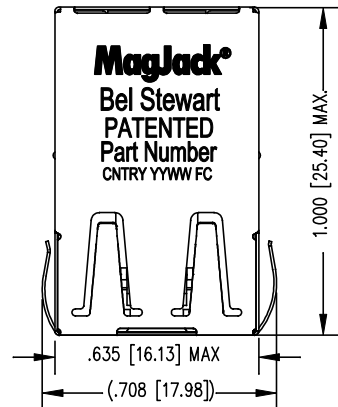

NOTES:

- CONNECTOR MATERIALS:  
HOUSING: THERMOPLASTIC UL94 V-0  
CONTACT/SHIELD: COPPER ALLOY  
SHIELD PLATING: NICKEL OR TIN  
CONTACT PLATING: 50 MICRO-INCH SELECTIVE HARD GOLD PLATING OR EQUIVALENT IN CONTACT AREA
- PIN NOT ELECTRICALLY CONNECTED MAYBE OMITTED. SEE ELECTRICAL DRAWING FOR OMITTED PINS.
- TOLERANCES COMPLY WITH F.C.C. DIMENSION REQUIREMENTS.
- ALL TOLERANCES NOT OTHERWISE SPECIFIED TO BE ±0.005 [0.13]
- REFLOW AND WAVE SOLDER COMPATIBLE -260°C FOR 10 SECONDS MAX.

ORIGINATED BY	DATE
Zeng Xiaochun	2012-04-18
DRAWN BY	DATE
Duan Jun	2012-04-18

TITLE	<b>MagJack®</b> 10/100BT, PoEP TAB UP, SHIELDED PATENTED
-------	---

PART NO. / DRAWING NO.	SI-52007-F
FILE NAME	SI-52007-F.DWG

STANDARD DIM.	[ ] METRIC DIM. AS REFERENCE
TOL. IN INCH	UNIT : INCH [mm]
.X	SCALE : N/A
.XX	REV. : 03
.XXX	SIZE : A4
±0.005	PAGE : 3

[ ] METRIC DIM. AS REFERENCE	REV. : 03
UNIT : INCH [mm]	SIZE : A4
SCALE : N/A	PAGE : 3



THE INFORMATION CONTAINED HEREIN IS CONSIDERED "PROPRIETARY" TO BEL FUSE INC. AND SHALL NOT BE COPIED, REPRODUCED OR DISCLOSED WITHOUT THE WRITTEN APPROVAL OF BEL FUSE INC.

RoHS

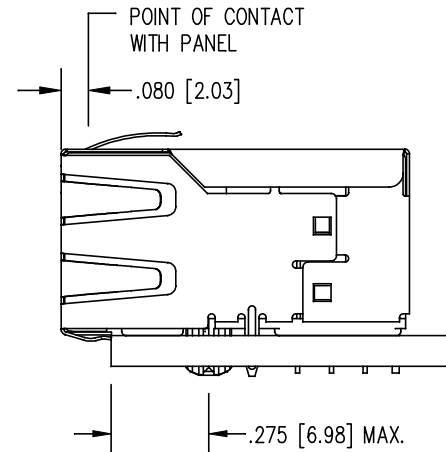
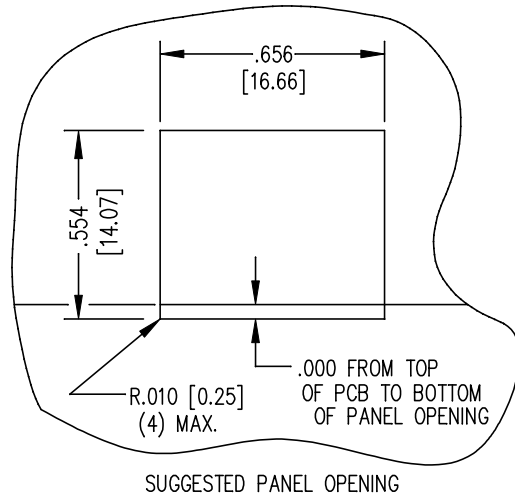

1. THE SUGGESTED PANEL OPENING IS INTENDED TO GIVE THE USER THE ABILITY TO HAVE REASONABLE JACK / PANEL CLEARANCES YET MAINTAIN RELIABLE GROUNDING CAPABILITY.
2. ALL TOLERANCES NOT OTHERWISE SPECIFIED TO BE  $\pm 0.005$  [0.13]

ORIGINATED BY	DATE	TITLE	PART NO. / DRAWING NO.	STANDARD DIM. TOL. IN INCH	[ ] METRIC DIM. AS REFERENCE	
Zeng Xiaochun	2012-04-18	<b>MagJack®</b> 10/100BT, PoEP TAB UP, SHIELDED PATENTED	SI-52007-F	.X	UNIT : INCH [mm]	REV. : 03
DRAWN BY	DATE		FILE NAME	.XX	SCALE : N/A	SIZE : A4
Duan Jun	2012-04-18		SI-52007-F.DWG	.XXX	$\pm 0.005$	

