

THE INFORMATION CONTAINED HEREIN IS CONSIDERED "PROPRIETARY" TO BEL FUSE INC. AND SHALL NOT BE COPIED, REPRODUCED OR DISCLOSED WITHOUT THE WRITTEN APPROVAL OF BEL FUSE INC.

RoHS



ELECTRICAL CHARACTERISTICS @ 25°C

1.0 TURNS RATIO:	(P1-P3):(J1-J2) (P4-P5):(J3-J6)	1CT : 1CT ±2% 1CT : 1CT ±2%
2.0 DC RESISTANCE:	(P1-P3):(P4-P5) (J1-J2):(J3-J6)	1.4 OHMS 1.2 OHMS
3.0 INDUCTANCE:	(P1-P3) (P4-P5)	350uH MIN. @ 0.1V, 100KHz, 8mA DC BIAS 350uH MIN. @ 0.1V, 100KHz, 8mA DC BIAS
4.0 LEAKAGE INDUCTANCE:	(P4-P5) WITH J6 AND J3 SHORT (P1-P3) WITH J2 AND J1 SHORT	0.3uH MAX. @ 1MHz 0.3uH MAX. @ 1MHz
5.0 INTERWINDING CAPACITANCE:	(P4,P5) TO (J3,J6) (P1,P2,P3) TO (J1,J2)	60pF TYP @ 1MHz 60pF TYP @ 1MHz
6.0 RETURN LOSS:	(P1-P3)=100 OHMS REF. AND (P4-P5)=100 OHM REF. 1MHz TO 30MHz 30MHz TO 60MHz 60MHz TO 80MHz	-18dB MIN. -(19-20LOG(f/30MHz)) 12dB MIN.
7.0 DIELECTRIC WITHSTAND:	(J3,J6) TO (P4,P5) (J1,J2) TO (P1,P3)	1500Vrms 1500Vrms
8.0 INSERTION LOSS:	RS=RL=100 OHMS 1MHz-65MHz	-1dB MAX
9.0 RISE TIME:	RS=RL=100 OHMS OUTPUT VOLTAGE = 1V PEAK PULSE WIDTH = 112nS	3.0nS MAX 3.0nS MAX
10.0 CROSS TALK:	1MHz-65MHz	-35dB MIN.
11.0 CM TO CM ATTENUATION:	30MHz TO 100MHz 100MHz TO 130MHz	-30dB MIN. -20dB MIN.
12.0 BALANCED DC LINE CURRENT:		350mA MAX @ 57 VDC CONTINUOUS 500mA MAX @ 57 VDC FOR 200 MILLSECONDS

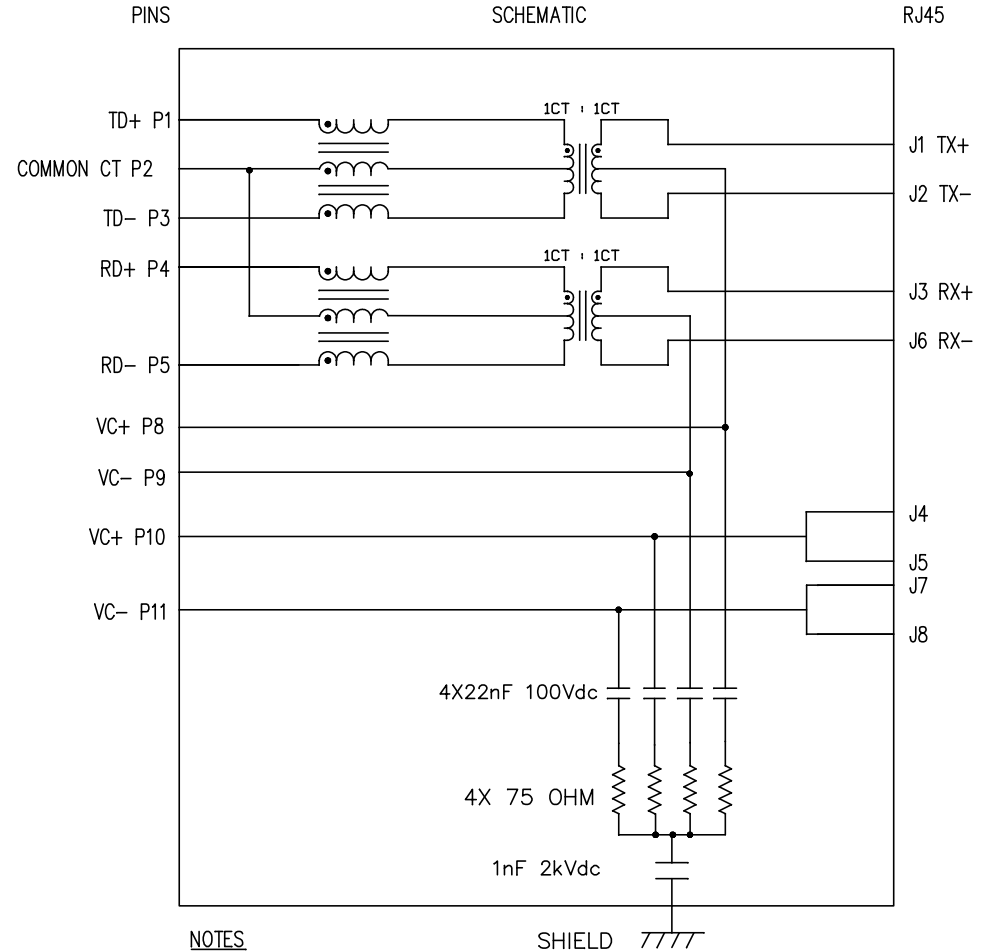

NOTES

1.0 DESIGNED TO SUPPORT IEEE 802.3

ORIGINATED BY Zeng Xiaochun	DATE SI-52003-F	TITLE MagJack® 10/100BT, PoE TAB UP, SHIELDED PATENTED	PART NO. / DRAWING NO. SI-52003-F	STANDARD DIM. TOL. IN INCH .X .XX .XXX ±0.005	[] METRIC DIM. AS REFERENCE		bel COMPONENTS FOR A CONNECTED PLANET
					UNIT : INCH [mm]	REV. : A1	
DRAWN BY Duan Jun	DATE SI-52003-F		FILE NAME SI-52003-F.DWG		SCALE : N/A	SIZE : A4	
						PAGE : 2	

THE INFORMATION CONTAINED HEREIN IS CONSIDERED "PROPRIETARY" TO BEL FUSE INC. AND SHALL NOT BE COPIED, REPRODUCED OR DISCLOSED WITHOUT THE WRITTEN APPROVAL OF BEL FUSE INC.

RoHS



LED SPECIFICATION			
STANDARD LED	WAVELENGTH	FORWARD V (MAX)	* (TYP)
GREEN	565 nm	2.5 V	2.2 V

*WITH A FORWARD CURRENT OF 20 mA (TYP)

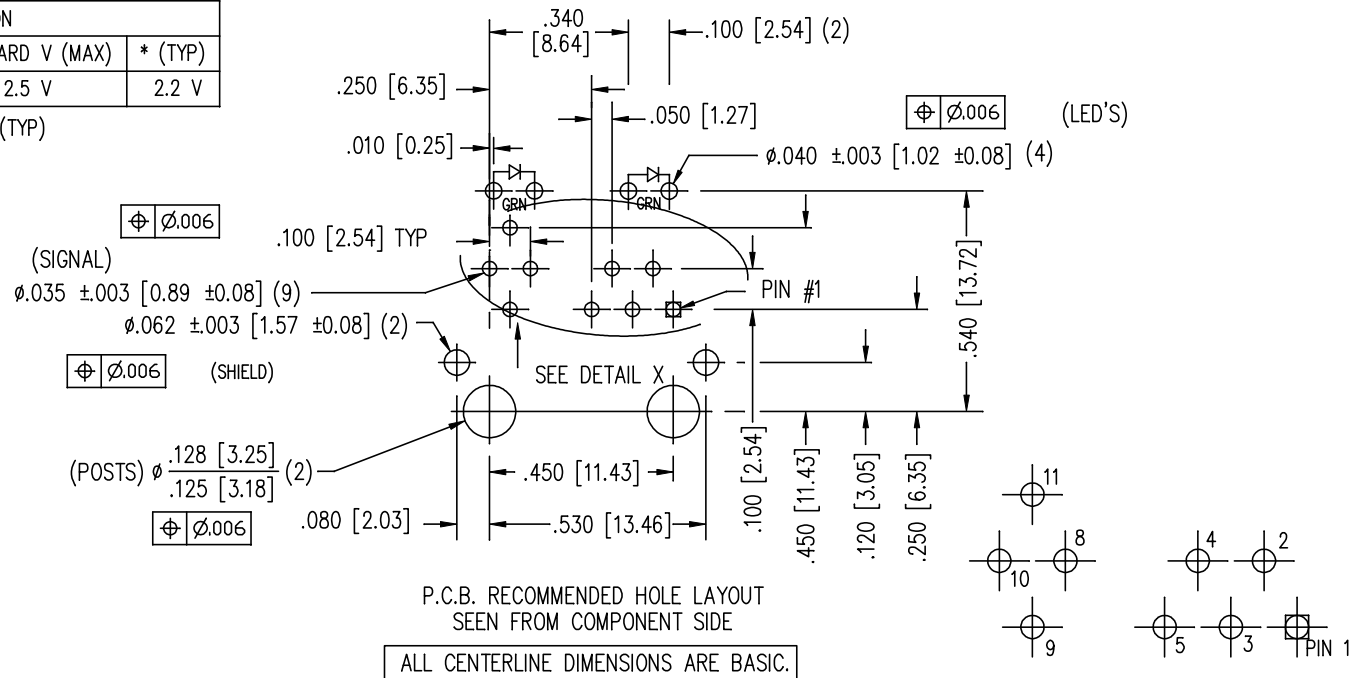
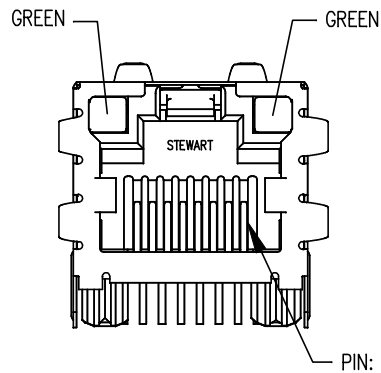
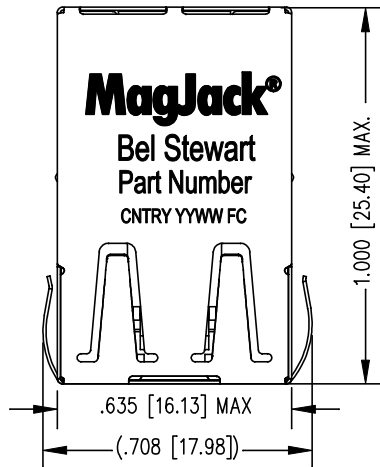

P.C.B. RECOMMENDED HOLE LAYOUT
SEEN FROM COMPONENT SIDE

ALL CENTERLINE DIMENSIONS ARE BASIC.

DETAIL X

NOTES:

- CONNECTOR MATERIALS:
HOUSING: THERMOPLASTIC UL94 V-0
CONTACT/SHIELD: COPPER ALLOY
SHIELD PLATING: NICKEL OR TIN
CONTACT PLATING: 50 MICRO-INCH SELECTIVE HARD GOLD PLATING OR EQUIVALENT IN CONTACT AREA
- PIN NOT ELECTRICALLY CONNECTED MAYBE OMITTED. SEE ELECTRICAL DRAWING FOR OMITTED PINS.
- TOLERANCES COMPLY WITH F.C.C. DIMENSION REQUIREMENTS.
- ALL TOLERANCES NOT OTHERWISE SPECIFIED TO BE ±.005 [0.13]
- REFLOW AND WAVE SOLDER COMPATIBLE -260°C FOR 10 SECONDS MAX.

ORIGINATED BY	DATE	TITLE	PART NO. / DRAWING NO.	STANDARD DIM.	[] METRIC DIM. AS REFERENCE	
Zeng Xiaochun	SI-52003-F	MagJack® 10/100BT, PoE TAB UP, SHIELDED PATENTED	SI-52003-F	TOL. IN INCH	UNIT : INCH [mm]	REV. : A1
DRAWN BY	DATE		FILE NAME	.X	SCALE : N/A	SIZE : A4
Duan Jun	SI-52003-F		SI-52003-F.DWG	.XX		PAGE : 3
				.XXX		±0.005



THE INFORMATION CONTAINED HEREIN IS CONSIDERED "PROPRIETARY" TO BEL FUSE INC. AND SHALL NOT BE COPIED, REPRODUCED OR DISCLOSED WITHOUT THE WRITTEN APPROVAL OF BEL FUSE INC.

RoHS

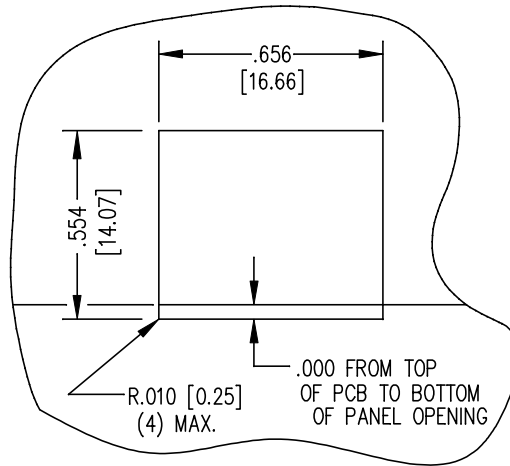

SUGGESTED PANEL OPENING

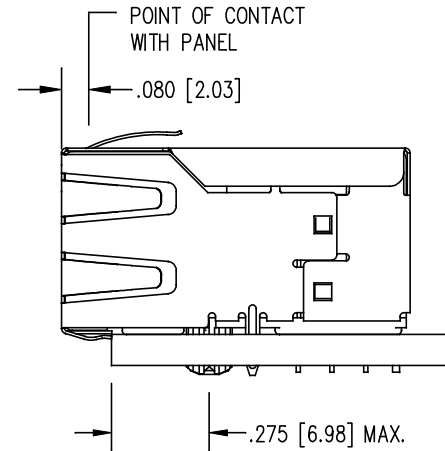

1. THE SUGGESTED PANEL OPENING IS INTENDED TO GIVE THE USER THE ABILITY TO HAVE REASONABLE JACK / PANEL CLEARANCES YET MAINTAIN RELIABLE GROUNDING CAPABILITY.
2. ALL TOLERANCES NOT OTHERWISE SPECIFIED TO BE ± 0.005 [0.13]

ORIGINATED BY	DATE	TITLE	PART NO. / DRAWING NO.	STANDARD DIM. TOL. IN INCH	[] METRIC DIM. AS REFERENCE	
Zeng Xiaochun	SI-52003-F	MagJack® 10/100BT, PoE TAB UP, SHIELDED PATENTED	SI-52003-F	.X	UNIT : INCH [mm]	REV. : A1
DRAWN BY	DATE		FILE NAME	.XX	SCALE : N/A	SIZE : A4
Duan Jun	SI-52003-F		SI-52003-F.DWG	.XXX	± 0.005	

