

THE INFORMATION CONTAINED HEREIN IS CONSIDERED "PROPRIETARY" TO BEL FUSE INC. AND SHALL NOT BE COPIED, REPRODUCED OR DISCLOSED WITHOUT THE WRITTEN APPROVAL OF BEL FUSE INC.

RoHS
2002/95/EC

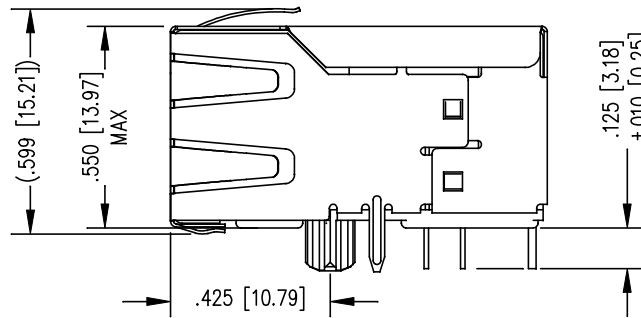
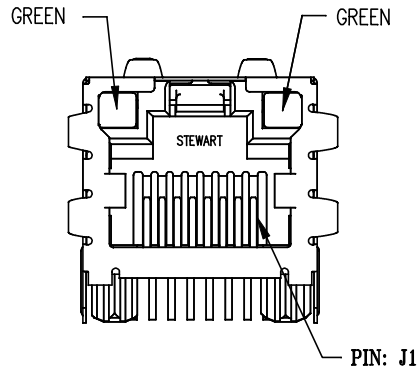
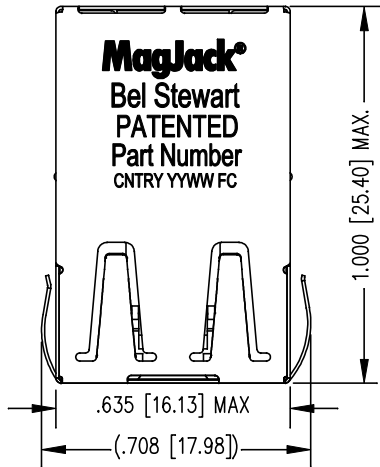

LED SPECIFICATION			
STANDARD LED	WAVELENGTH	FORWARD V (MAX)	* (TYP)
GREEN	565 nm	2.5 V	2.2 V

*WITH A FORWARD CURRENT OF 20 mA (TYP)

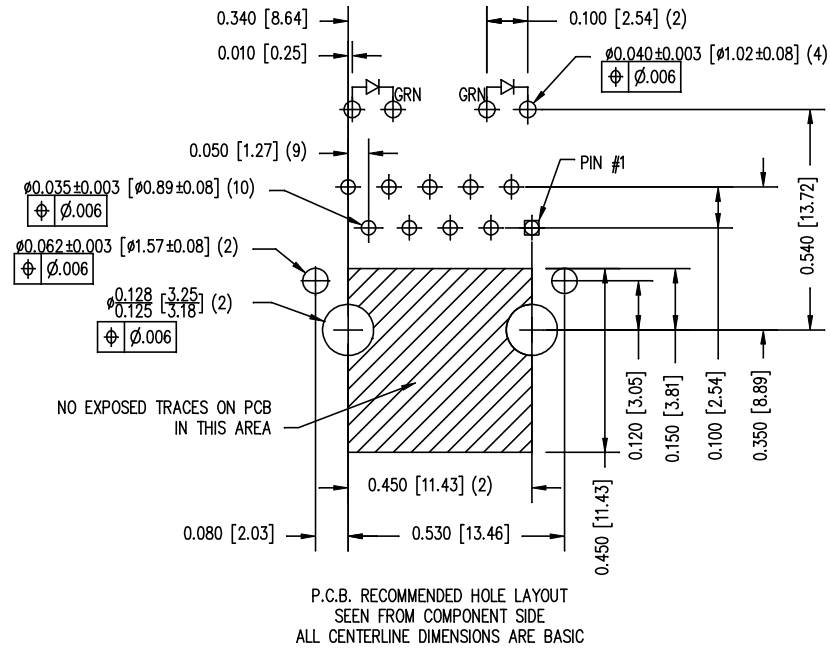

NOTES:

- CONNECTOR MATERIALS:
HOUSING: THERMOPLASTIC UL94 V-0
CONTACT/SHIELD: COPPER ALLOY
SHIELD PLATING: NICKEL OR TIN
CONTACT PLATING: SELECTIVE GOLD,
50 MICRO-INCHES MIN. IN CONTACT AREA.
- PIN NOT ELECTRICALLY CONNECTED MAYBE OMITTED.
SEE ELECTRICAL DRAWING FOR OMITTED PINS.
- TOLERANCES COMPLY WITH F.C.C. DIMENSION REQUIREMENTS.
- ALL TOLERANCES NOT OTHERWISE SPECIFIED TO BE ±0.05 [0.13]
- REFLOW AND WAVE SOLDER COMPATIBLE -260°C FOR 10 SECONDS MAX.

ORIGINATED BY	DATE
Zeng Xiao Chun	03-21-2011
DRAWN BY	DATE
Zhang Ru Sheng	03-21-2011

TITLE	MagJack® TAB UP SHIELDED 10/100/100BT PATENTED
-------	--

PART NO. / DRAWING NO.	SI-51021-F
FILE NAME	SI-51021-F.DWG

STANDARD DIM.	[] METRIC DIM. AS REFERENCE
TOL. IN INCH	UNIT : INCH [mm]
.X	REV. : 02
.XX	SCALE : N/A
.XXX	SIZE : A4
±0.005	PAGE : 3

UNIT : INCH [mm]	REV. : 02
SCALE : N/A	SIZE : A4
SIZE : A4	PAGE : 3



THE INFORMATION CONTAINED HEREIN IS CONSIDERED "PROPRIETARY" TO BEL FUSE INC. AND SHALL NOT BE COPIED, REPRODUCED OR DISCLOSED WITHOUT THE WRITTEN APPROVAL OF BEL FUSE INC.

RoHS
2002/95/EC

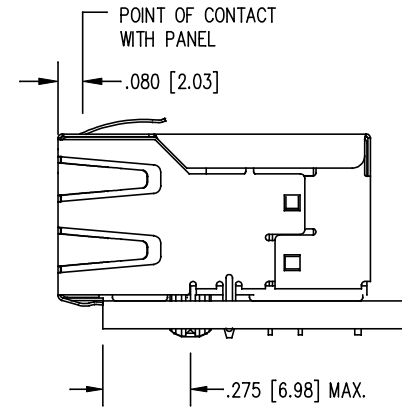
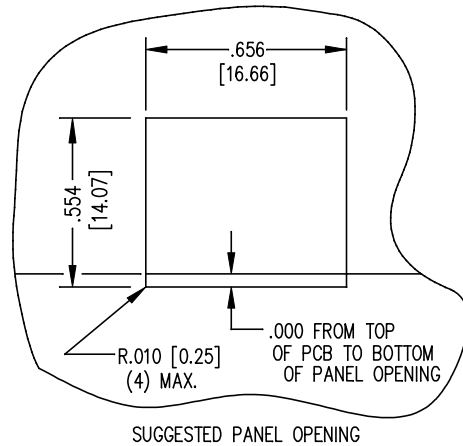

1. THE SUGGESTED PANEL OPENING IS INTENDED TO GIVE THE USER THE ABILITY TO HAVE REASONABLE JACK / PANEL CLEARANCES YET MAINTAIN RELIABLE GROUNDING CAPABILITY.
2. ALL TOLERANCES NOT OTHERWISE SPECIFIED TO BE ± 0.005 [0.13]

ORIGINATED BY Zeng Xiao Chun	DATE 03-21-2011	TITLE MagJack® TAB UP SHIELDED 10/100/100BT PATENTED	PART NO. / DRAWING NO. SI-51021-F	STANDARD DIM. TOL. IN INCH	[] METRIC DIM. AS REFERENCE	 COMPONENTS OR A CONNECTED PLANET
DRAWN BY Zhang Ru Sheng	DATE 03-21-2011	FILE NAME SI-51021-F.DWG	.X	UNIT : INCH [mm]	REV. : 02	
			.XX	SCALE : N/A	SIZE : A4	
			.XXX	± 0.005	PAGE : 4	