

THE INFORMATION CONTAINED HEREIN IS CONSIDERED "PROPRIETARY" TO BEL FUSE INC. AND SHALL NOT BE COPIED, REPRODUCED OR DISCLOSED WITHOUT THE WRITTEN APPROVAL OF BEL FUSE INC.

RoHS
2002/95/EC



ELECTRICAL CHARACTERISTICS @ 25°C

URNS RATIO

TP1	1CT : 1CT ±2%
TP2	1CT : 1CT ±2%
TP3	1CT : 1CT ±2%
TP4	1CT : 1CT ±2%

□CL @ 100kHz/100mVRMS
8mA DC BIAS

350µH MIN.

INS. LOSS

0.1MHz TO 1MHz	-1.1 dB MAX
1MHz TO 65MHz	-0.5 dB MAX
65MHz TO 100MHz	-0.8 dB MAX
100MHz TO 125MHz	-1.2 dB MAX

RET. LOSS (MIN)

0.5MHz-40MHz	-18 dB
40MHz-100MHz	-12+20LOG(f/80MHz) dB

CM TO CM REJ

100kHz - 100MHz	-30 dB MIN
-----------------	------------

CM TO DM REJ

100kHz - 100MHz	-35 dB MIN
-----------------	------------

HIPOT (Isolation Voltage): 1500 Vrms
100% OF PRODUCTION TESTED TO COMPLY
WITH IEEE 802.3 ISOLATION REQUIREMENTS.

OPERATING TEMPERATURE: -40 TO +85°C

SCHEMATIC

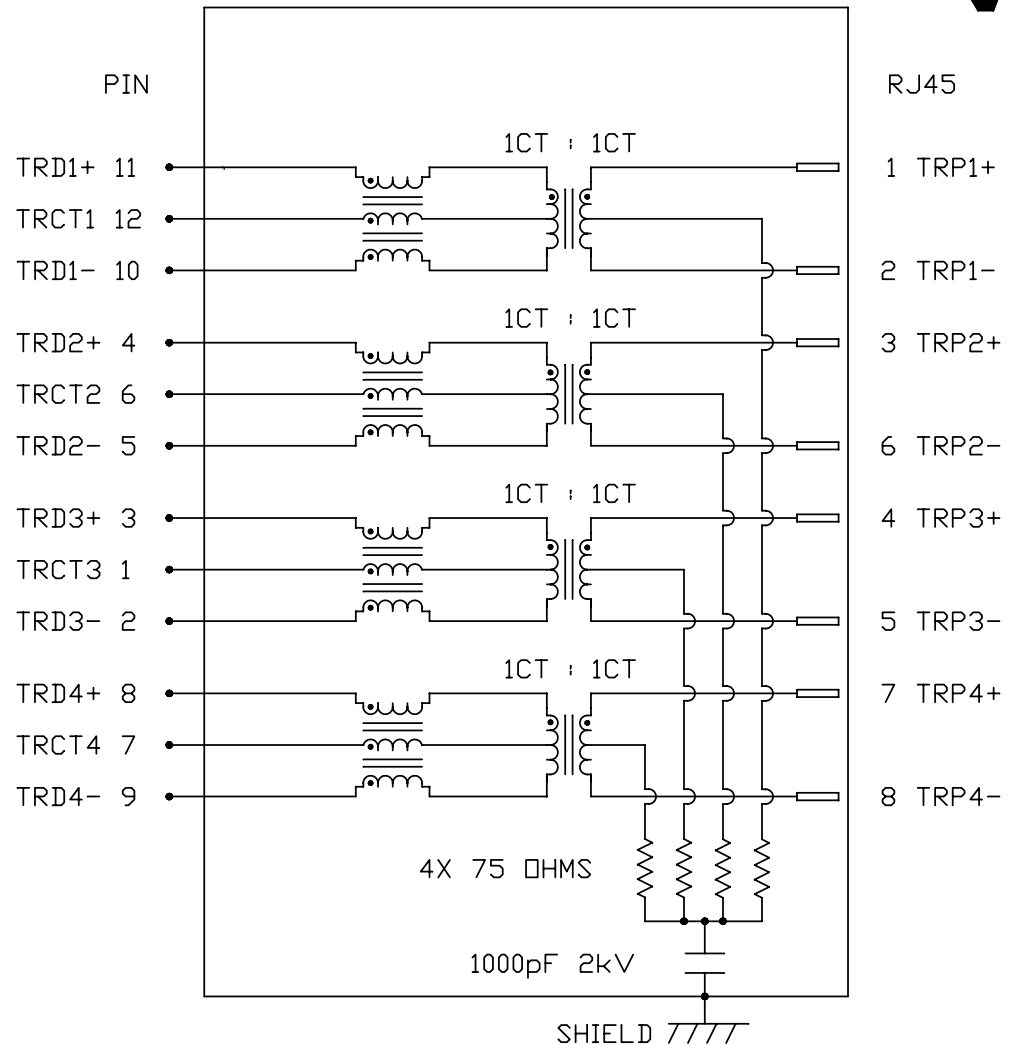

ORIGINATED BY CHOW WANGCHUNG	DATE 12-09-10	TITLE gigabit MagJack® (Extended Temperature and 50µinch gold plating) L8AL-1X1T-32A PATENTED	PART NO. / DRAWING NO. L8AL-1X1T32A	STANDARD DIM. TOL. IN INCH	[] METRIC DIM. AS REFERENCE	bel COMPONENTS FOR A CONNECTED PLANET	
DRAWN BY LEE WEIDE	DATE 12-09-10		FILE NAME L8AL-1X1T32A_A.DWG	.X .XX .XXX	UNIT : INCH [mm] SCALE : N/A		REV. : A SIZE : A4 PAGE : 2

THE INFORMATION CONTAINED HEREIN IS CONSIDERED "PROPRIETARY" TO BEL FUSE INC. AND SHALL NOT BE COPIED, REPRODUCED OR DISCLOSED WITHOUT THE WRITTEN APPROVAL OF BEL FUSE INC.

MECHANICAL SPECIFICATION

RoHS
2002/95/EC

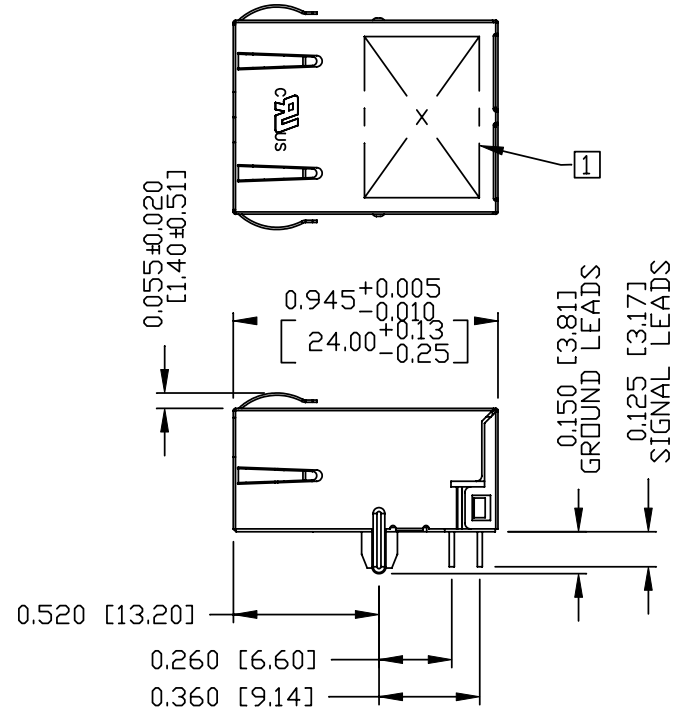
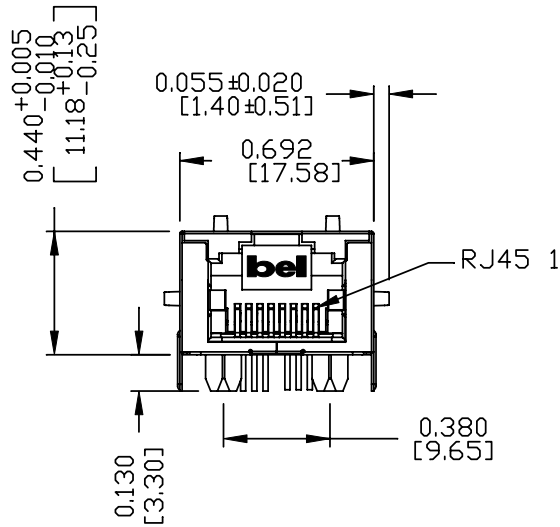

NOTES:

- PLASTIC HOUSING: THERMOPLASTIC PA
- CONTACTS: FLAMMABILITY RATING UL 94V-0
- CONTACTS: 50 MICRO-INCH HARD GOLD PLATING
- OUTPUT PINS: TIN-COATED COPPER WIRE, DIA 0.018 INCH.
- METAL SHIELD: NICKEL PLATED ON COPPER ALLOY,
(ALL GROUND LEADS ARE SOLDER DIPPED)

- [1] MARK PART WITH MFG. LOGO, MFG. NAME, PART NUMBER L8AL-1X1T-32A AND DATE CODE AND PATENTED.
- 2. RoHS COMPLIANCE, PER EU DIRECTIVE 2002/95/EC.
- 3. JACK CAVITY CONFORMS TO FCC RULES AND REGULATIONS.
- 4. THE PRODUCT IS PATENTED, THE PATENT NUMBER ARE U.S. PAT. 5,736,910 AND U.S. PAT. 6,840,817 AND U.S. PAT. 7,123,117.

c US UL RECOGNIZED - FILE #E196366 AND E169987.

ORIGINATED BY CHEN BILL	DATE 12-09-10	TITLE gigabit MagJack® (Extended Temperature and 50uinch gold plating) L8AL-1X1T-32A PATENTED	PART NO. / DRAWING NO. L8AL-1X1T32A		STANDARD DIM. TOL. IN INCH		[] METRIC DIM. AS REFERENCE		
			FILE NAME L8AL-1X1T32A_A.DWG		.X .XX .XXX	±0.010	UNIT : INCH [mm] SCALE : N/A	REV. : A SIZE : A4 PAGE : 3	
DRAWN BY XIAN JIAXIN	DATE 12-09-10								

THE INFORMATION CONTAINED HEREIN IS CONSIDERED "PROPRIETARY" TO BEL FUSE INC. AND SHALL NOT BE COPIED, REPRODUCED OR DISCLOSED WITHOUT THE WRITTEN APPROVAL OF BEL FUSE INC.

RoHS
2002/95/EC



RECOMMENDED PCB FOOTPRINT
COMPONENT SIDE VIEW

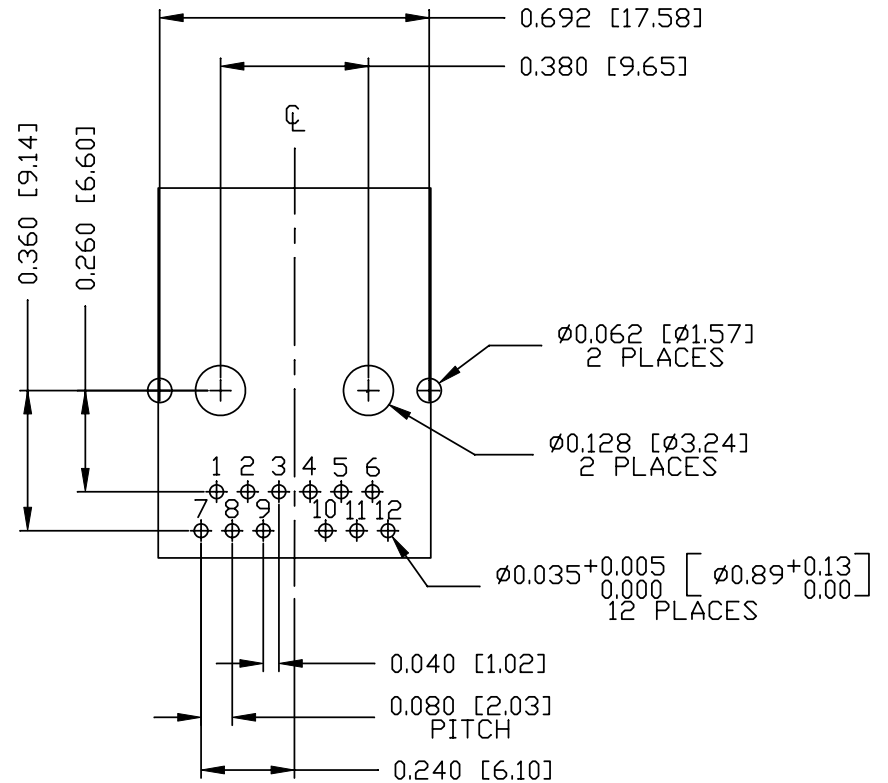
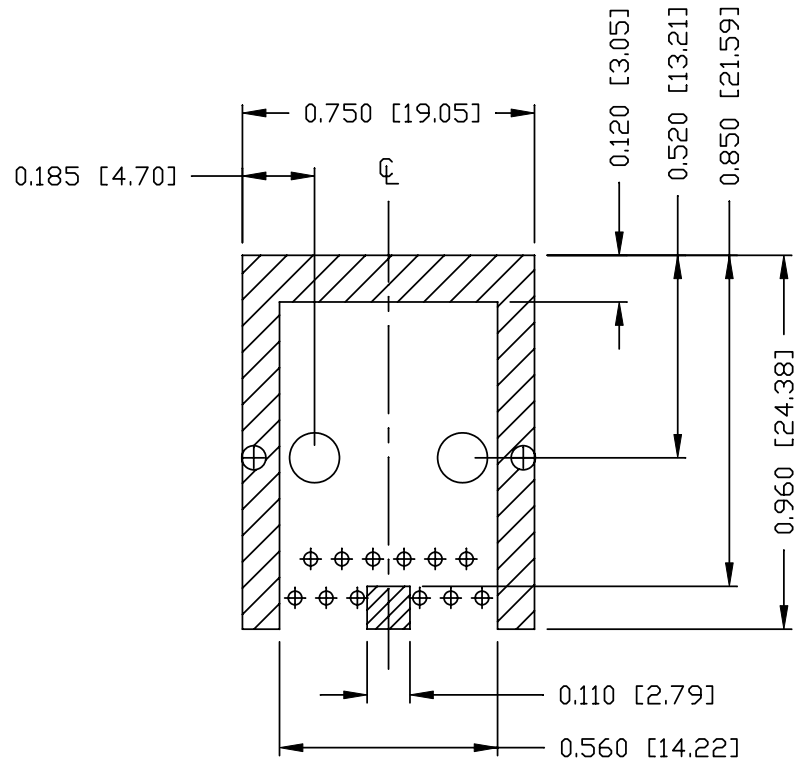

NOTES:

THE SHADED AREA ON THE CUSTOMER BOARD ARE RECOMMENDED TO BE CLEAR OFF ANY VIA HOLE OR COMPONENT PAD.

ORIGINATED BY CHEN BILL	DATE 12-09-10	TITLE gigabit MagJack® (Extended Temperature and 50micinch gold plating) L8AL-1X1T-32A PATENTED	PART NO. / DRAWING NO. L8AL-1X1T32A		STANDARD DIM. TOL. IN INCH		[] METRIC DIM. AS REFERENCE		 COMPONENTS FOR A CONNECTED PLANET
			FILE NAME L8AL-1X1T32A_A.DWG		.X .XX .XXX	±0.004	UNIT : INCH [mm] SCALE : N/A	REV. : A SIZE : A4 PAGE : 4	

THE INFORMATION CONTAINED HEREIN IS CONSIDERED "PROPRIETARY" TO BEL FUSE INC. AND SHALL NOT BE COPIED, REPRODUCED OR DISCLOSED WITHOUT THE WRITTEN APPROVAL OF BEL FUSE INC.



SUGGESTED PANEL OPENING

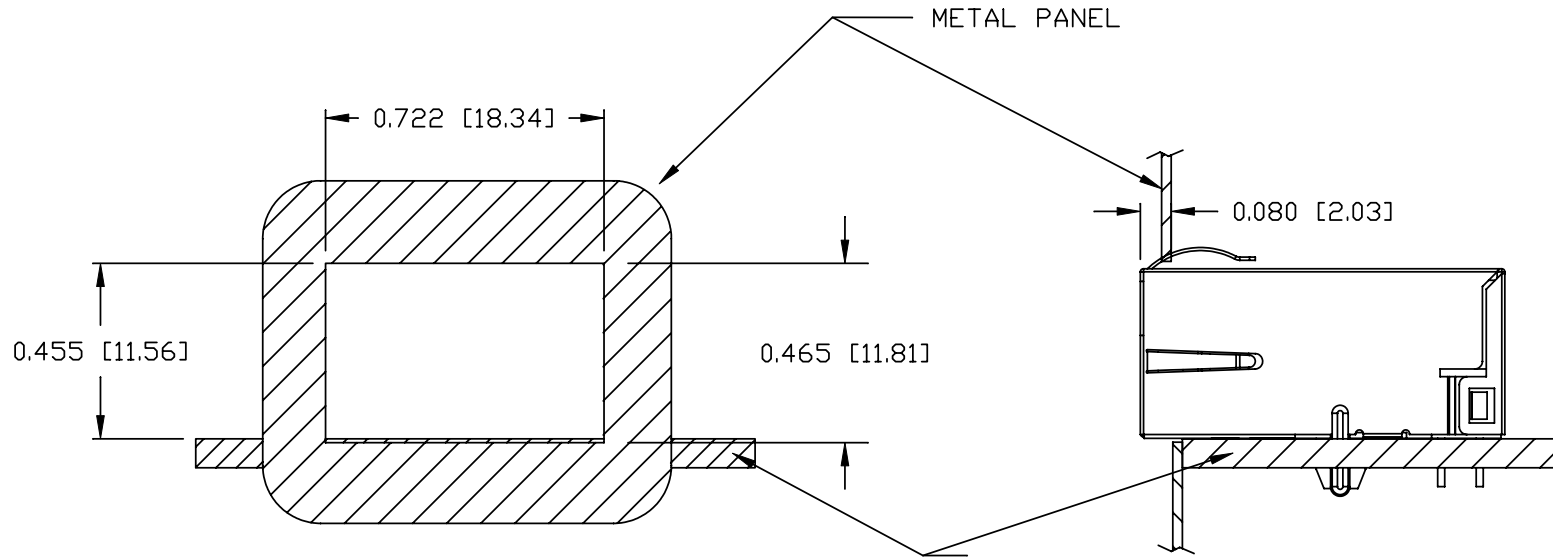

NOTE:

THE DISTANCE OF PANEL INSIDE SURFACE RELATIVE TO FRONT SURFACE OF PART IS ONLY A SUGGESTION. IN CASE THIS DISTANCE IS DIFFERENT, THE REQUIRED PANEL OPENING DIMENSIONS CHANGE ACCORDINGLY.

TRAY PACKING INFORMATION

PACKING TRAY : 0200-9999-E4 (TOP)

0200-9999-E5 (BOTTOM)

PACKING QUANTITY : 60 PCS FINISHED GOODS PER TRAY

11 TRAYS (660 PCS FINISHED GOODS) PER CARTON BOX

NOTE : CARDBOARDS ARE PLACED BETWEEN LAYERS OF PACKING TRAY INSIDE CARTON BOX (INCLUDE THE UPPERMOST AND LOWERMOST TRAY)

ORIGINATED BY CHEN BILL	DATE 12-09-10	TITLE gigabit MagJack® (Extended Temperature and 50inch gold plating) L8AL-1X1T-32A PATENTED	PART NO. / DRAWING NO. L8AL-1X1T32A		STANDARD DIM. TOL. IN INCH		[] METRIC DIM. AS REFERENCE		bel COMPONENTS FOR A CONNECTED PLANET
			FILE NAME L8AL-1X1T32A_A.DWG		.X		UNIT : INCH [mm]	REV. : A	
DRAWN BY XIAN JIAXIN	DATE 12-09-10				.XX		SCALE : N/A	SIZE : A4	PAGE : 5
					.XXX	±0.004			