

1. Functional Description of the AMG-SM101

The AMG-SM101 is a sensor IC for inductive proximity applications and can be used with a range of inductive transducers. It does have the analog front end, the detection logic, output stage and the LED drivers integrated.

2. Features

- Supply voltage 5.5VDC ... 38VDC
- Fully integrated low cost proximity sensor IC
- User-adjustable sensing range
- User-adjustable hysteresis (0...15%)
- Can work with a broad selection of inductive transducers
- Voltage regulator to improve immunity against fluctuations of supply voltage
- Inactive output during start-up
- NPN open collector output with guaranteed sink current of 150mA
- Output overload/overcurrent protection
- Broad range of operating frequency: 100kHz...1MHz
- Broad operating temperature range: -25°C...90°C
- Package QFN24

3. Application

The AMG-SM101 is suitable for many inductive proximity detection applications.

3.1. Example Application

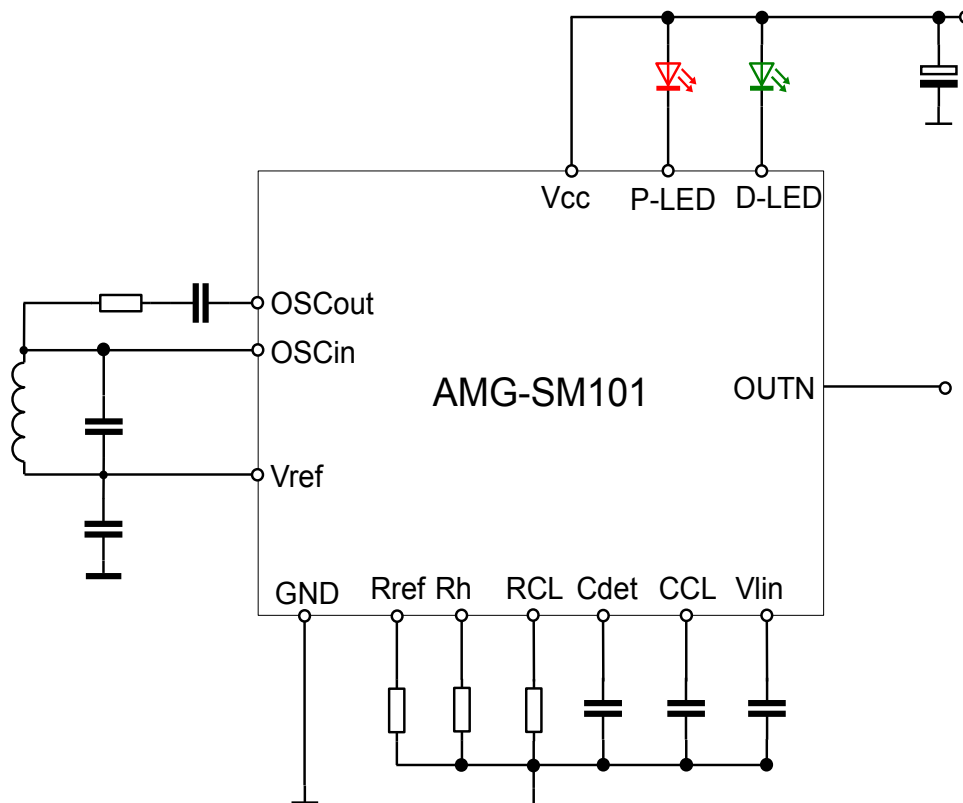

Figure 1: Example Application

3.2. Application Notes

Please see AMG-AN-SM101.

Table of Contents

1.Functional Description of the AMG-SM101.....	1
2.Features.....	1
3.Application.....	1
3.1.Example Application	2
3.2.Application Notes.....	2
4.Block Diagram.....	4
5.Block Descriptions.....	4
5.1.LC Oscillator.....	4
5.2.Oscillation Detector.....	4
5.3.Normally Open/Normally Closed (NO/NC) Block.....	5
5.4.Reference Voltage and Current Generator.....	5
5.5.Linear Voltage Regulator.....	5
5.6.Output and LED Drivers.....	5
5.7.Overload Protection Circuits.....	6
5.8.Output NPN Transistor.....	6
6.Pinning.....	6
7.Absolute Maximum Ratings.....	8
8.Electrical Characteristics.....	9
8.1.Operational Range.....	9
8.2.DC Characteristics.....	10
8.3.AC Characteristics.....	11
9.Application.....	12
9.1.Example Application Circuit.....	12
9.2.Application Notes.....	12
9.3.Thermal Considerations.....	13
9.4.Surge Protection.....	13
10.Ordering Information.....	13
11.IC-Package.....	14
12.IC-Marking.....	15
13.Notes and Cautions.....	15
13.1.ESD Protection.....	15
13.2.Storage conditions.....	15
14.Disclaimer.....	15
15.Contact Information.....	17

4. Block Diagram

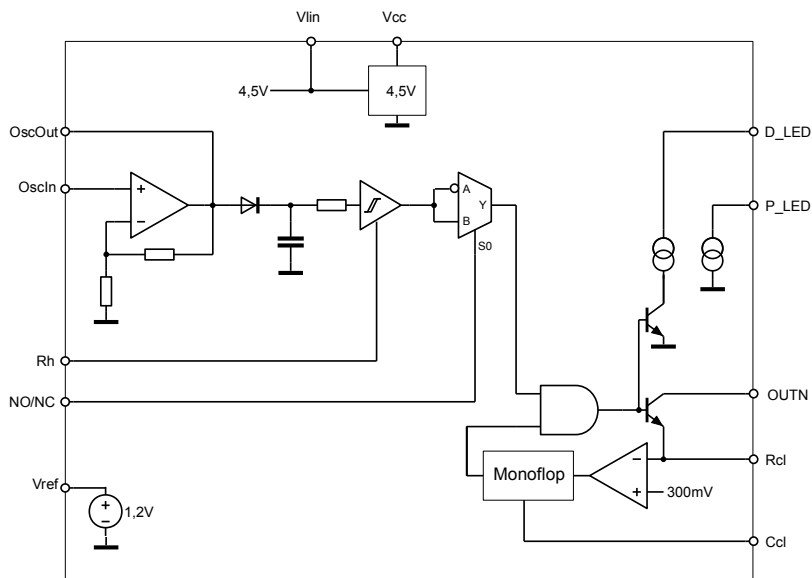

Figure 2: Block Diagram

5. Block Descriptions

5.1. LC Oscillator

The LC oscillator utilises the operational amplifier OA featuring a high gain-bandwidth product. The positive feedback of this operational amplifier produces negative resistance at Pin OSCin to compensate for energy losses in an external LC tank.

The LC oscillator generates a sinusoidal 100kHz...1MHz signal as long as no metallic object is present within the sensing range of the sensor. As soon as a metallic object is placed in close proximity of the external inductor (called proximity transducer in proximity detection applications) its Q factor drops due to eddy currents induced in the object. This leads to higher energy losses in the LC tank, and if the distance between the transducer and the object is small enough, the oscillations are broken.

5.2. Oscillation Detector

This block, consisted of a peak detector, low-pass filter and comparator with hysteresis, determines whether the oscillator oscillates or not. It also implements a hysteresis function. The output of the detector is used to drive, through the NO/NC multiplexer, the output drivers of the chip. The detector features a dedicated pin Cdet to connect an external capacitor controlling the cut-off frequency of the low-pass filter. This low pass filter eliminates malfunction of the sensor in the presence of short interfering signals which might be received by the magnetic field-sensitive inductive transducer. Therefore, if the IC is expected to work in a 'harsh' environment it is advised that the value of C_F be increased at the expense of reaction time of the IC.

Inductive Proximity Sensor IC

5.3. Normally Open/Normally Closed (NO/NC) Block

The NO/NC block and its NO/NC pin are responsible for the output logic of the IC: the output logic can either be normally open (the output is off if no object is detected) or normally closed (the output is on if no object is detected).

Object detected	NO/NC	State of the output and detect LED
NO	Not connected	OFF
NO	GND	ON
YES	Not connected	ON
YES	GND	OFF

5.4. Reference Voltage and Current Generator

This block provides the IC with a single reference voltage of about 1.2V and a set of reference currents, which are used to bias all building blocks of the IC.

5.5. Linear Voltage Regulator

Since the level of external supply voltage of the IC is expected to vary considerably, an internal voltage regulator has been used to improve the immunity of the LC Oscillator and Oscillation Detector against variations thereof. In this way the influence of supply voltage on the sensing distance of the sensor has been minimised. This voltage regulator can supply external circuitry within the current limits given in section 8.2

5.6. Output and LED Drivers

This block senses the output of the NO/NC Block and uses this information to drive the NPN output transistor. Additionally, it provides a bias current for two external LEDs: the Power LED and the Detect LED.

Inductive Proximity Sensor IC

5.7. Overload Protection Circuits

The function of this block is to protect the output transistor against destruction resulting from attempting to sink excessive current into the IC or shorting the output of the IC directly to the supply rail. The overload/overcurrent state of the IC is detected by comparing an internal reference voltage with the voltage drop over an external current limiting resistor connected in series with the emitter of the output transistor. The voltage threshold over the shunt resistor necessary to switch the protection circuit is given in section 8.2. If the overload/overcurrent state is detected (threshold exceeded), the state of the output is periodically sampled as long as the overload/overcurrent condition persists. In this state the average overload current flowing through the load is much lower than its guaranteed value in the normal operation mode, and the value of this overload current is given in Section 8.2.

Apart from protecting the output transistor the Overload Protection block is also responsible for deactivating the output transistor shortly after the supply voltage was applied to the sensor. In this way undesired transient behaviour of the IC output is suppressed.

5.8. Output NPN Transistor

The output NPN transistor is capable of sinking at least 150mA of constant output current. In the overload mode the transistor delivers short current pulses used to test the state of the output and to provide a small charge (or overload) current for capacitive loads.

6. Pinning

PIN#	Symbol	Description
1	D_LED	Detect LED (1.2mA)
2,3	OutN	NPN output (open drain)
4,5	RCL	Current limiting resistor of NPN output transistor
6		n. c.
7	NO/NC	Normally open / normally closed switch
8		n.c.
9	C _{DET}	Oscillation detector capacitor (CDET to GND)
10	R _{REF}	Reference resistor
11	C _{CCL}	Current limiter sampling capacitor
12		n.c.
13	GND	Ground
14		n.c.
15	Vlin	Regulator blocking capacitor
16	VCC	Supply voltage
17	OSCin	Oscillator input (LC tank)

Inductive Proximity Sensor IC

PIN#	Symbol	Description
18	OSCOut	Oscillator output
19		n.c.
20	R _H	Hysteresis adjustment
21	Vref	Reference voltage output (connect C to GND)
22	PGND	Power Ground
23	P_LED	Power LED (1.2mA)
24		n.c.

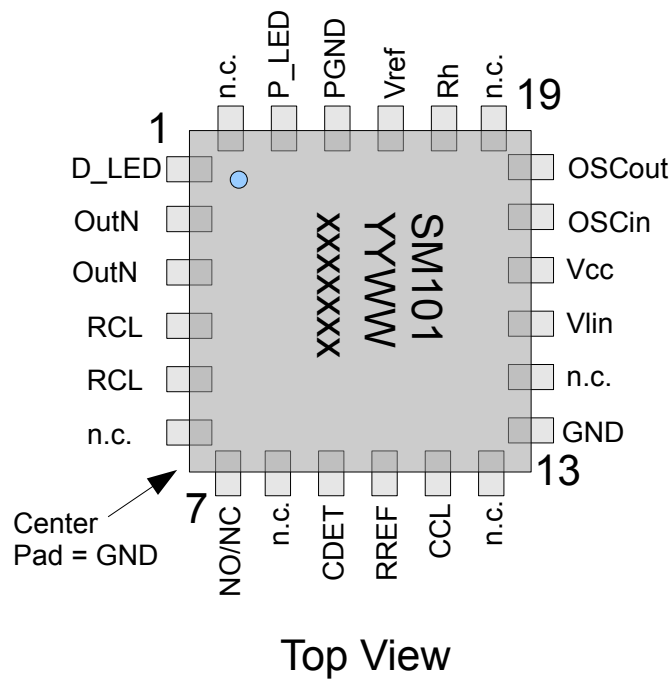

Fig.3: QFN24 Pinout

7. Absolute Maximum Ratings

The Absolute Maximum Ratings may not be exceeded under any circumstances.

#	Symbol	Parameter	Min	Max	Unit
1	V _{CC}	Supply voltage	-0.3	40	V
2	V _{MAX}	Voltages at pins NO/NC, L1, Rh, Rf, Cdet, Rref, Vref, Vlin, Covl	-0.3	Vlin + 0.3	V
3	V _{ESD}	ESD test voltage* ¹⁾	-1	1	kV
4	T _{STG}	Storage temperature range	-55	150	°C
5	T _{SOLD}	Soldering temperature		300	°C
6	T _J	Junction temperature * ²⁾		150	°C

Note:

*¹⁾ Human Body Model

*²⁾ $T_J = T_A + P_{TOT} \cdot R_{THJ-A}$, where T_A is ambient temperature, P_{TOT} is total power dissipation and R_{THJ-A} is thermal resistance junction-ambient

8. Electrical Characteristics

8.1. Operational Range

#	Symbol	Parameter	Min	Max	Unit
1	V _{CC,AVG}	Average supply voltage at pin VCC* ¹⁾	7	35	V
2	V _{CC,DC}	DC supply voltage* ²⁾ * ³⁾	5.5	38	V
3	T _A	Ambient temperature range	-25	90	°C
4	T _J	Junction temperature	-25	120	°C
5	P _{TOT}	Total power dissipation		1	W
6	R _{THJ-A}	Thermal resistance junction-ambient		42	K/W

Note: *¹⁾ amplitude of allowable low-frequency ripple (100-120Hz) is not higher than +/-10%

*²⁾ for supply voltages below 6.5V, it is mandatory to use low ESR blocking caps

*³⁾ for supply voltages below 6.5V, it is mandatory that the supply is stable

Inductive Proximity Sensor IC

8.2. DC Characteristics

The typical values are given for $V_{CC} = 24V$, $T_j = 25^\circ C$ unless otherwise specified.

#	Symbol	Parameter	Min	Typ	Max	Unit
1	$I_{VCC,OFF}$	Supply current of pin VCC (Output off)		3.8	4.8	mA
2	$I_{VCC,ON}$	Supply current of pin VCC (Output on)		8.5	12	mA
3	$V_{SAT,OUT}$	Output saturation voltage ($I_{out} = 150mA$)		0.50	0.70	V
4	I_{LED}	LED current	1.0	1.2	1.6	mA
5	I_{OVL}	Average overload current	5	8	14	mA
6	I_{LKG}	Output leakage current			5	μA
7	$V_{TH,OVL}$	Overload threshold voltage ^{*4)}	250	290	330	mV
8	V_{lin}	Output of linear regulator ^{*5)}	4.1	4.45	4.8	V
9	I_{lin}	External load for lin. regulator			5	mA
10	V_{drop}	Min. dropout of lin. regulator	1.5	1.7	1.9	V
11	V_{ref}	Voltage reference		1.2		V
12	I_{ref}	External load for reference			100	μA

Note:

^{*4)} overload threshold voltage is the level of the voltage across the current limiting resistor which triggers the overload protection circuit; for more information on this refer to Section 5.7.

^{*5)} for supply voltages below 6.5V, V_{lin} will follow V_{cc} less the dropout voltage

Inductive Proximity Sensor IC

8.3. AC Characteristics

The typical values are given for $V_{CC} = 24V$, $T_J = 25^\circ C$ unless otherwise specified.

#	Symbol	Parameter	Min	Typ	Max	Unit
1	f_{OSC}	Operating frequency (set by ext. LC tank)	0.1		1.0	MHz
2	R_N	Negative resistance at pin L1	-200		-2	k Ω
3	f_{cutoff}	Detector filter frequency	2		7	kHz
4	H_W	Hysteresis width (set by R_{hys})	0		15	%
5	t_R	Output rise time (@ 1k Ω load)		<1.5		μs
6	t_F	Output fall time (@ 1k Ω load) *2)		<1		μs
7	$T_{S,OVL}$	Sampling period in overload mode (set by C_{OVL})	50	120	250	ms
8	$T_{STARTUP}$	Startup time*3)	50	120	250	ms
9	C_{MAX}	Maximum output capacitance for regular loads*4)			10	nF
10	C_{IN}	Input capacitance	6	8.5	13	pF
11	Δd_{sense}	Sensing distance vs. Vcc		1	2	%

Note:

*2) fall time right after start-up depends on the load used and can be as long as 10ms

*3) this is the maximum start-up time of the IC itself; this parameter does not reflect performance of a sensor; during start-up the output is inactive (off) regardless of the state of the NO/NC pin

*4) for more information on capacitive loads refer to Overload Explanation in Section 5.7.

9. Application

Inductive Proximity

9.1. Example Application Circuit

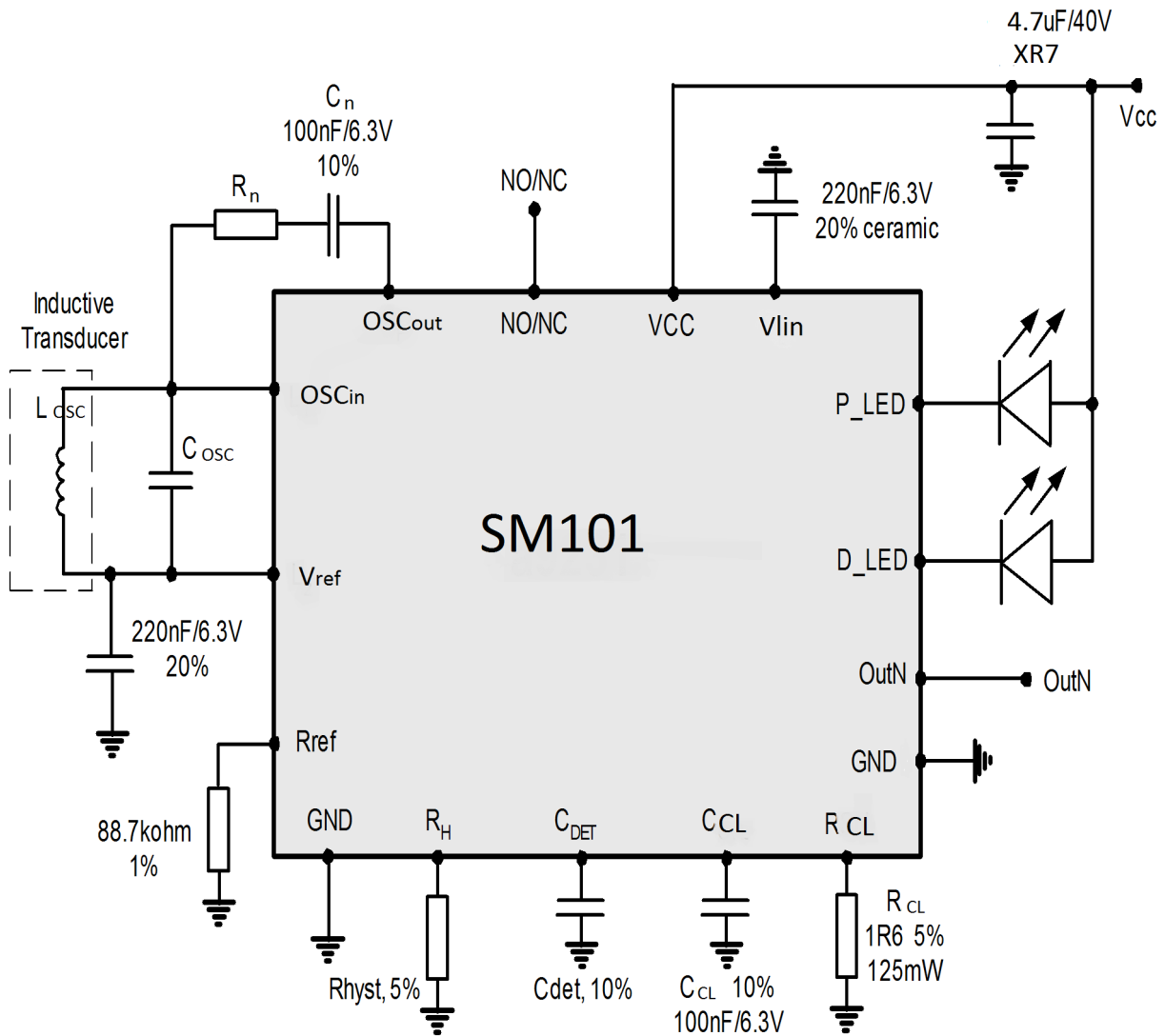

Figure 3: Example Application Circuit

9.2. Application Notes

AMG-AN-SM101

9.3. Thermal Considerations

The SM101's QFN24 package has limited power dissipation capabilities. In case the ambient temperature is rising above 78°C, the package requires extra cooling to prevent the junction temperature to rise above specified limits.

Such cooling can be achieved by having a GND layer in the PCB and connecting that with vias to the center pad of the QFN24.

Such cooling can be calculated, but as a rule of thumb, a 150mm² GND area under the IC, connecting to the center pad with 16 vias will provide for sufficient cooling. If 150mm² cooling area cannot be achieved, one should try to create star type traces originating from the center pad location to the rim of the PCB. This will work as heat pipes.

9.4. Surge Protection

Depending on the necessary surge protection class, surge protection diodes and low pass filter schemes might be necessary to protect the Vcc and OutN pins.

For more information please refer to AMG-AN-SM101.

10. Ordering Information

AMG-SM101-IQN24R	(QFN24	shipment in tape & reel)
------------------	--------	--------------------------

11. IC-Package

QFN24

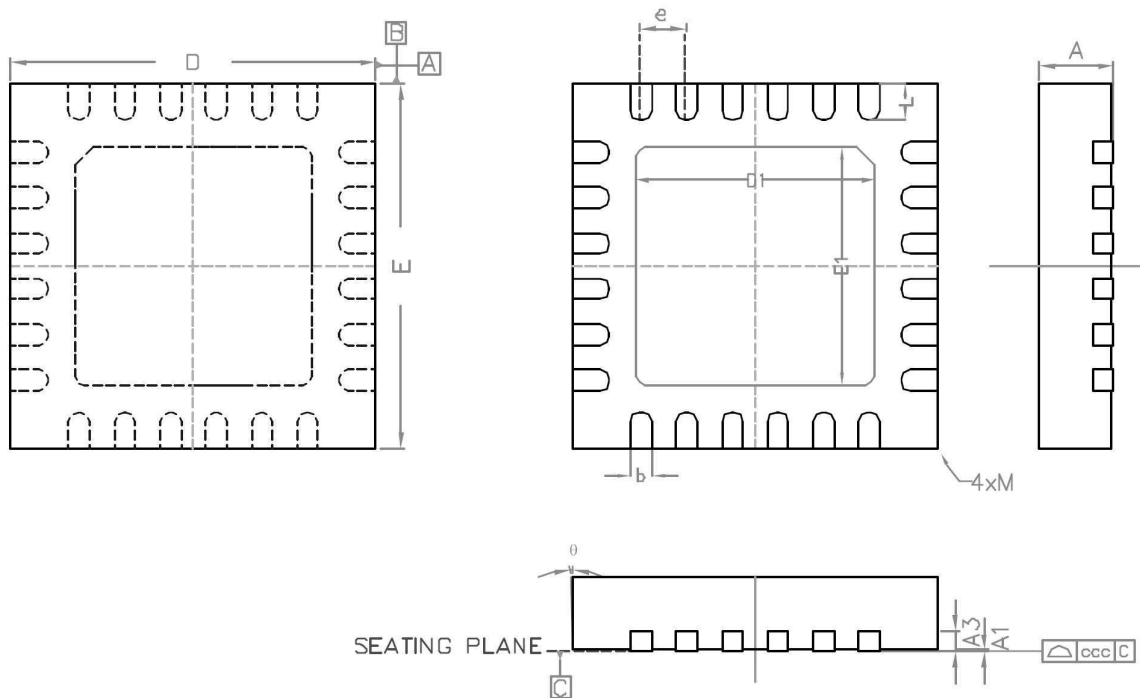

SYMBOL	Dimensions in mm, angles in deg		
	MIN	NOM	MAX
A	0.80	0.85	0.90
A1	0	0.010	0.030
A3	-	0.20	-
b	0.18	0.23	0.28
D	3.95	4.00	4.03
D1	-	2.60	-
E	3.95	4.00	4.03
E1	-	2.60	-
e	-	0.50	-
L	0.35	0.4	0.45
θ	-12	-	0
ccc	-	0.08	-
M	-	-	0.05

Inductive Proximity Sensor IC

12. IC-Marking

Top Marking by Laser

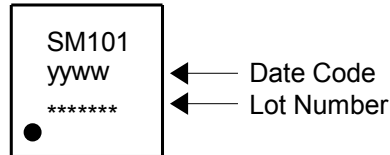

13. Notes and Cautions

13.1. ESD Protection

The Requirements for Handling Electrostatic Discharge Sensitive Devices are described in the JEDEC standard JESD625-A. Please note the following recommendations:

- When handling the device, operators must be grounded by wearing a for the purpose designed grounded wrist strap with at least 1MΩ resistance and direct skin contact.
- Operators must at all times wear ESD protective shoes or the area should be surrounded by for ESD protection intended floor mats.
- Opening of the protective ESD package that the device is delivered in must only occur at a properly equipped ESD workbench. The tape with which the package is held together must be cut with a sharp cutting tool, never pulled or ripped off.
- Any unnecessary contact with the device or any unprotected conductive points should be avoided.
- Work only with qualified and grounded tools, measuring equipment, casing and workbenches.
- Outside properly protected ESD-areas the device or any electronic assembly that it may be part of should always be transported in EGB/ESD shielded packaging.

13.2. Storage conditions

The AMG-SM101 corresponds to moisture sensitivity classification ML2, according to JEDEC standard J-STD-020, and should be handled and stored according to J-STD-033.

14. Disclaimer

Information given in this data sheet is believed to be accurate and reliable. However, no responsibility is assumed for the consequences of its use nor for any infringement of patents or other rights of third parties that may result from its use. alpha microelectronics gmbh does not authorize or warrant any of its products for use in life support system equipment.

The values stated in Absolute Maximum Ratings may under no circumstances be exceeded. No warranty is given for use in life support systems or medical equipment without the specific written consent of alpha microelectronics gmbh. For questions regarding the application please contact the publisher.

The declared data are only a description of the product. They are not guaranteed properties as defined by law. Examples are given without obligations and cannot give rise to any liability.

Inductive Proximity Sensor IC

Reprinting of this data sheet – or any part of it – is not allowed without the license of the publisher. Data sheets are subject to change without any notice.

15. Contact Information

This data sheet is published by alpha microelectronics gmbh. To order samples or inquire information please contact:

alpha microelectronics gmbh
Im Technologiepark 1
15236 Frankfurt (Oder)
Germany

am.info@alpha-microelectronics.de
www.alpha-microelectronics.de

+49-335-557-1750 (telephone)
+49-335-557-1759 (fax)

© All rights reserved.

