

High Efficiency Step Down LED Driver for High Brightness LED and OLED

1. Functional Description of the AMG-LL75X

The AMG-LL75X is an universal step down LED driver module for high brightness LED and OLED. By providing a highly efficient constant current regulation off a DC source the AMG-LL75x is perfectly suited for applications that require low DC levels for safety reasons, driving multiple LED groups in one luminaire, mobile or in-vehicle, and to refit existing low voltage halogen installations.

2. Features

- Supply voltage: 7VDC...30VDC
- Maximum output power: 10W
- LED current: 350mA
- PWM input for dimming & disable
- Efficiency up to 96%
- 1...5 white LEDs (maximum ~20V forward voltage)
- Standby current 3.5mA
- Over current protection
- Reverse polarity protection
- Crimp, plug & solder connectors
- MTTF >100,000h
- Module size : 30mm x 16.5mm x 7mm
- RoHS compliant

2.1. Application Circuit Example

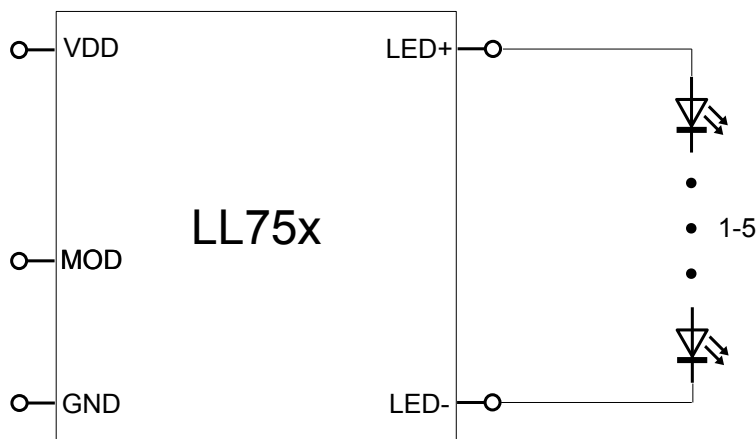

Figure 1: Simplified application example



Table of Contents

1.Functional Description of the AMG-LL75X.....	1
2.Features.....	1
2.1.Application Circuit Example.....	1
3.Picture.....	3
4.Pinning / Pad Coordinates.....	3
5.Absolute Maximum Ratings.....	4
6.Electrical Characteristics.....	4
6.1.Operational Range.....	4
7.Application.....	5
7.1.Thermal Precautions.....	5
7.2.Failure Modes.....	5
7.3.Recommended Safety Measures.....	5
7.4.Application Notes.....	6
8.Ordering Information	11
9.Module Dimensions.....	11
10.Board-Revision.....	11
11.Notes and Cautions.....	11
11.1.ESD Protection.....	11
11.2.Storage conditions.....	12
12.Disclaimer.....	12
13.Contact Information.....	12

3. Picture

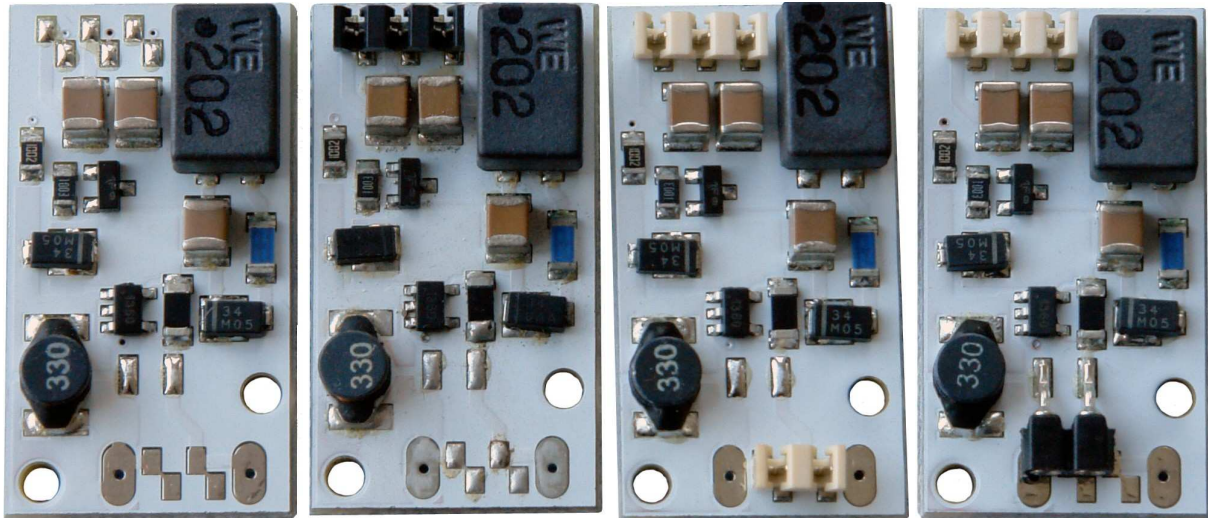
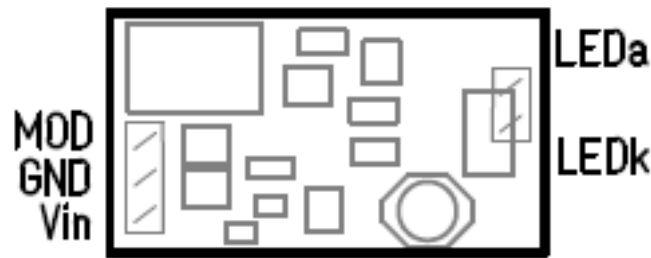

Figure 2: Example Picture

4. Pinning / Pad Coordinates

Symbol	Description
Vin	Supply voltage positive input. Apply a DC voltage of 7V to 30V here. The input is protected with a fuse and a diode to prevent damage from reserved power supply and safely disconnect the power in case of failure.
GND	Supply voltage negative input and ground reference for MOD input.
LEDa	Positive output for LED, connect the anode of the first LED of the string to this pin.
LEDk	Negative output for LED, connect the cathode of the last LED of the string to this pin. This pin is not identical to GND!
MOD	PWM input. Pulling this pin high shuts off the output. Feeding a PWM signal with up to 1kHz can be used to control the brightness of the connected LEDs. Pulling the pin high permanently puts LW05 in a standby mode. This can be left unconnected if no brightness control is required.

High Efficiency Step Down LED Driver for High Brightness LED and OLED



5. Absolute Maximum Ratings

The Absolute Maximum Ratings may not be exceeded under any circumstances.

#	Parameter	Min	Max	Unit
1	Input Voltage (V_{in} relative to GND)*	-40	+30	V
2	MOD pin input voltage (relative to GND)	-0.3	V_{in}	-
3	Input Current: 1A	-	-	-
	Operating Temperature:			
4	LW05-200**	-30	+85	°C
5	LW05-350**	-30	+85	°C

Note(s):

- * - (40V for 0.5 sec)
- ** - in still air

6. Electrical Characteristics

6.1. Operational Range

#	Symbol	Parameter	Min	Max	Unit
1	V_{in}	Input Voltage	7	30	V
2	$I_{standby}$	Standby current (MOD = high)		3,5	mA

Note(s):

7. Application

7.1. Thermal Precautions

When operating at elevated ambient temperature, vertical mounting in an air volume sufficiently large enough to allow convection is recommended to reduce surface temperature of the regulator. Additional cooling measures can help to further reduce the regulator temperature and increase long term reliability. No part of the module surface may exceed 125°C during the operation at any time.

7.2. Failure Modes

The most common failure mode occur when the regulator is destroyed due to over temperature, overvoltage, or an internal short circuit that causes the fuse to disconnect. The fuse has the ability to disconnect failure currents up to 50A and will start to trip at 1A.

7.3. Recommended Safety Measures

Materials with low flash points must be kept away from the regulator. The surface temperature of parts on the regulator may reach up to 125°C surface temperature when used at elevated ambient temperatures and maximum power.

High Efficiency Step Down LED Driver for High Brightness LED and OLED

7.4. Application Notes

a) Connecting the LEDs

The maximum of LEDs that can be driven by the AMG-LL75x depends on the supply voltage and the combined forward voltage of the LEDs. Input voltage needs to be approximately 2.5V higher than the total forward voltage of the LED string for the proper operation.

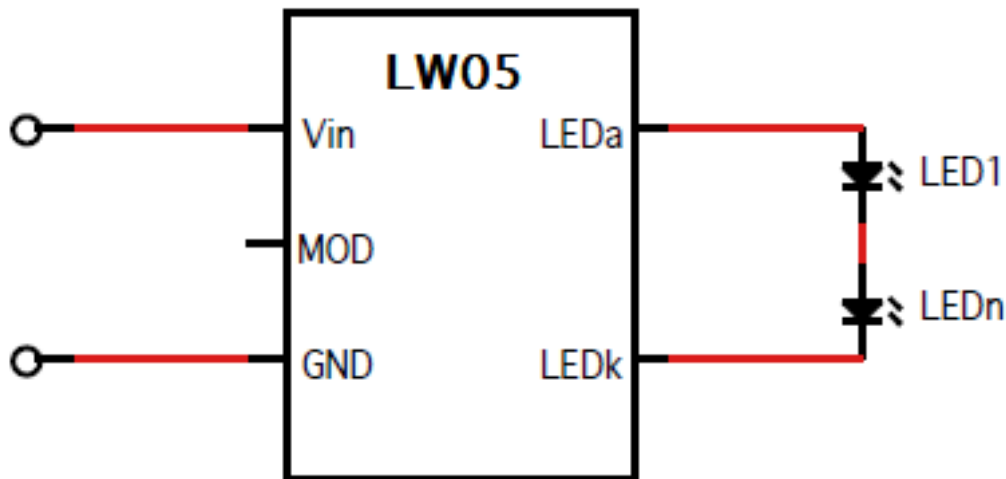

b) Reducing Output Ripple

To reduce output ripple and possibly reducing EMC problems a capacitor maybe put parallel to the LEDs, preferably connected direct between LEDa and LEDk of the AMG-LL75x. The 200mA low ripple version comes equipped with a capacitor installed on the module to optimize it for use with OLED.

c) EMC

The AMG-LL75x has been designed to produce a minimal level of EM emissions. As a component this product cannot be EMC approved.

d) Brightness Control

The MOD input allows PWM dimming of the LEDs. By applying a voltage $>1V \leq V_{in}$ the current to the LEDs is shut off. Frequencies up to about 1kHz can be applied to the MOD input, though for good regulator stability it is recommended not to exceed 500Hz. Dimming ranges of about 1% to 100% are possible.

e) Regulator Efficiency

The regulator efficiency depends on a number of parameters. Since there are a couple constant losses independent of the total power delivered by the regulator the basic rule is that the regulator is more efficient when used at high power (e.g. more LEDs connected). A lower difference between input and output voltage does also increase efficiency.

High Efficiency Step Down LED Driver for High Brightness LED and OLED

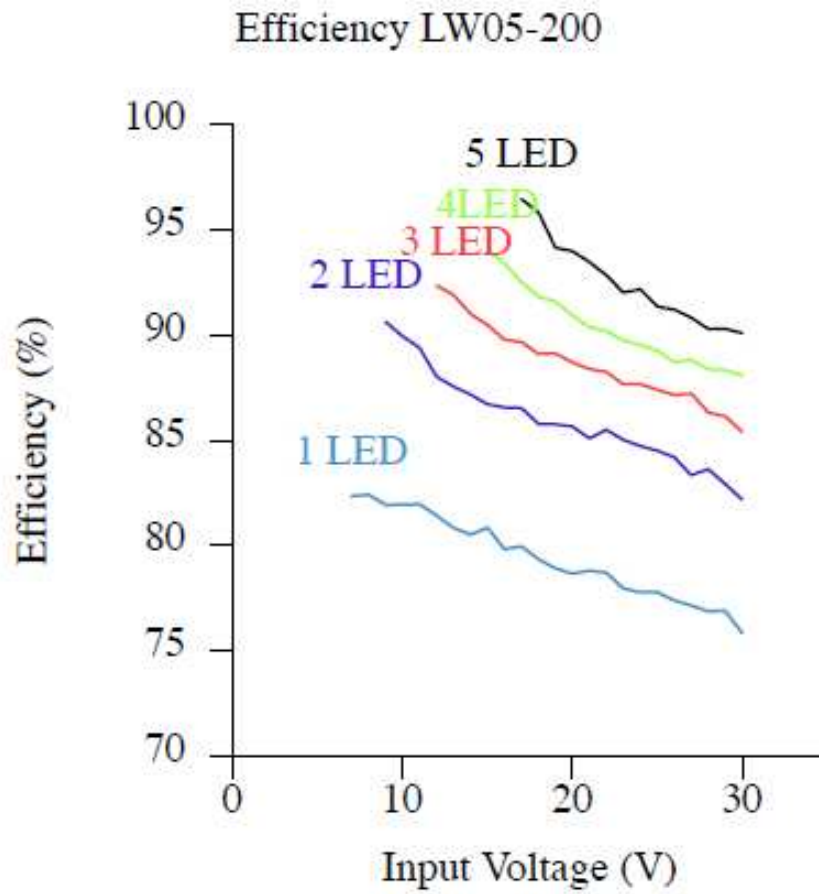

High Efficiency Step Down LED Driver for High Brightness LED and OLED

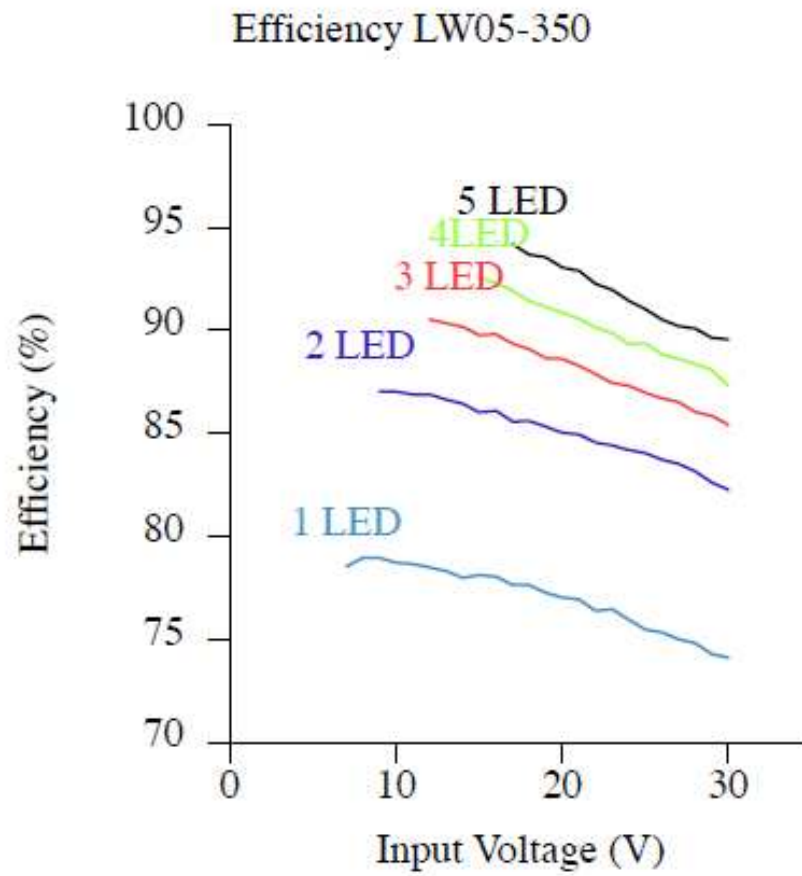

High Efficiency Step Down LED Driver for High Brightness LED and OLED

f) Output current

The output current varies somewhat depending on the forward voltage of LEDs and the input voltage. If a more precise output current is required it can be set by using the MOD input.

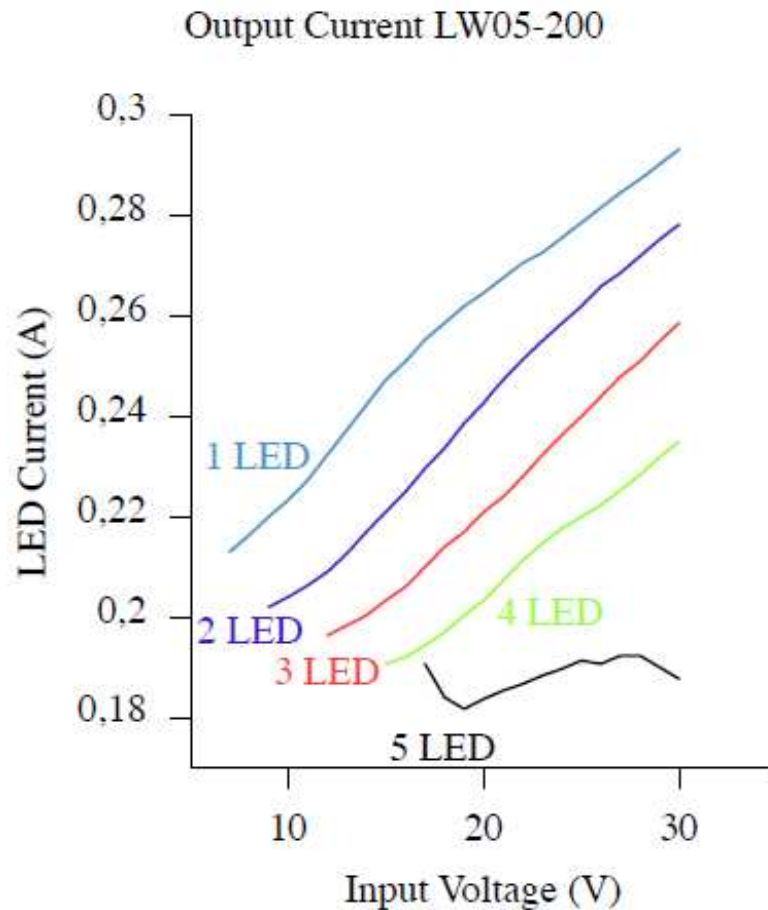

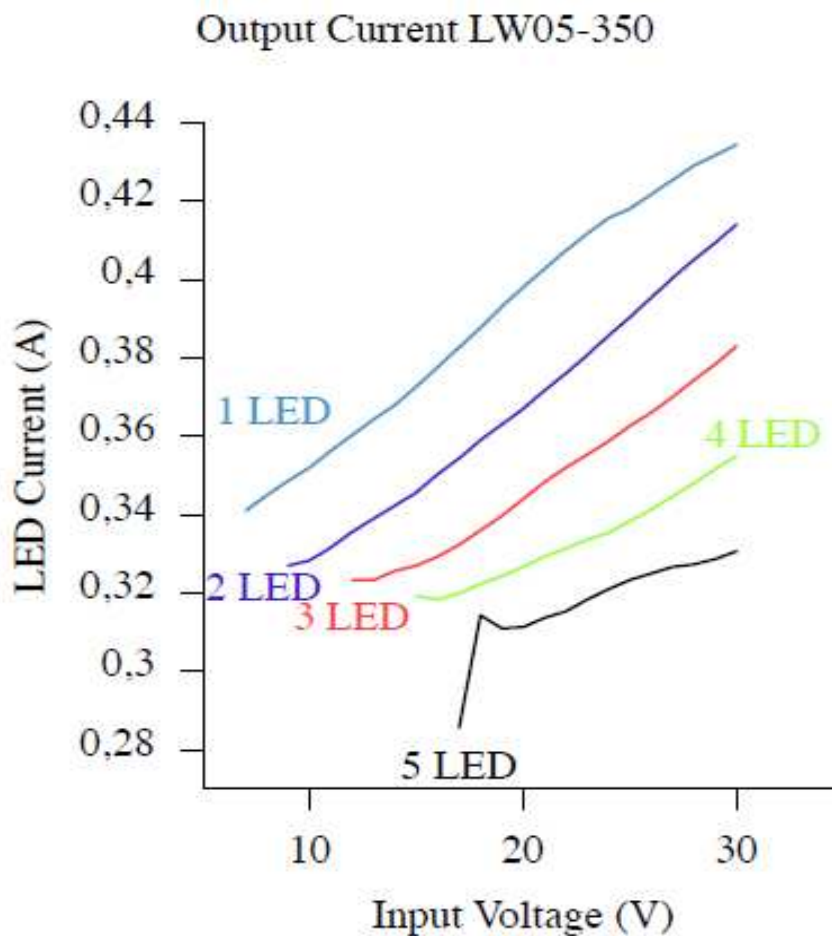

g) Reliability

The reliability data is based on the data provided by component manufacturers:

Failure Rate (FIT): $1337 * 10^{-9}h^{-1}$

Mean Time to Failure (MTTF): 747943h

h) Identifying Current Values

The AMG-LL75x modules are marked with a color dot to identify the current value of the module. The color dot also serves to identify that the module has been tested and is in good standing. The color dot can be located on the input filter (the black square part next to the input connector) of the module. Color coding can be located in the "Ordering Information" table.

8. Ordering Information

Order Code	Color Code	Description
AMG-LL751-IPM05E	Orange	350mA regulator, input solder, output solder
AMG-LL752-IPM05E	Orange	350mA regulator, input crimp, output solder
AMG-LL753-IPM05E	Orange	350mA regulator, input crimp, output plug
AMG-LL754-IPM05E	Orange	350mA regulator, input crimp, output crimp
AMG-LL755-IPM05E	Red	200mA regulator, low ripple, input solder, output solder
AMG-LL756-IPM05E	Red	200mA regulator, low ripple, input crimp, output crimp

Note(s):

9. Module Dimensions

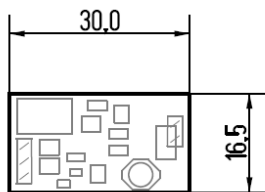

Dimensions in mm

Height at thickest point: 6.5mm

Tolerances: -

Outer Contour: ± 0.2 mm

When mounting on a conductive surface make sure to add spacers or an insulating layer under the module to avoid short circuits.

a) Crimp Connectors

The crimp connectors used on the LW05 require a special crimping tool. Crimping tools can be purchased separately. Wires with insulation diameter 0.7 to 1mm fit into the connectors.

10. Board-Revision

4 digit board revision code

11. Notes and Cautions

11.1. ESD Protection

The Requirements for Handling Electrostatic Discharge Sensitive Devices are described in the JEDEC standard JESD625-A. Please note the following recommendations:

High Efficiency Step Down LED Driver for High Brightness LED and OLED

- When handling the device, operators must be grounded by wearing a for the purpose designed grounded wrist strap with at least 1MΩ resistance and direct skin contact.
- Operators must at all times wear ESD protective shoes or the area should be surrounded by for ESD protection intended floor mats.
- Opening of the protective ESD package that the device is delivered in must only occur at a properly equipped ESD workbench. The tape with which the package is held together must be cut with a sharp cutting tool, never pulled or ripped off.
- Any unnecessary contact with the device or any unprotected conductive points should be avoided.
- Work only with qualified and grounded tools, measuring equipment, casing and workbenches.
- Outside properly protected ESD-areas the device or any electronic assembly that it may be part of should always be transported in EGB/ESD shielded packaging.

11.2. Storage conditions

The AMG-LL75X corresponds to moisture sensitivity classification **ML2**, according to JEDEC standard J-STD-020, and should be handled and stored according to J-STD-033.

12. Disclaimer

Information given in this data sheet is believed to be accurate and reliable. However, no responsibility is assumed for the consequences of its use nor for any infringement of patents or other rights of third parties that may result from its use. alpha microelectronics GmbH does not authorize or warrant any of its products for use in life support system equipment.

The values stated in Absolute Maximum Ratings may under no circumstances be exceeded. No warranty is given for use in life support systems or medical equipment without the specific written consent of alpha microelectronics gmbh. For questions regarding the application please contact the publisher.

The declared data are only a description of the product. They are not guaranteed properties as defined by law. Examples are given without obligations and cannot give rise to any liability. Reprinting of this data sheet – or any part of it – is not allowed without the license of the publisher. Data sheets are subject to change without any notice.

13. Contact Information

This data sheet is published by alpha microelectronics gmbh. To order samples or inquire information please contact:

alpha microelectronics gmbh
Im Technologiepark 1
15236 Frankfurt (Oder)
Germany

am.info@alpha-microelectronics.de
www.alpha-microelectronics.de

+49-335-557-1750 (telephone)
+49-335-557-1759 (fax)

© All rights reserved.



