

Description

The GM324, a quad internal frequency compensated operational amplifiers with true differential inputs, which operate from a single power supply over a wide range of voltages. They have several distinct advantages over standard operational amplifier types in single supply applications. The quad amplifier can operate at supply voltages as low as 3.0V or as high as 32V with extremely low quiescent current (on a single amplifier basis). The common mode input range includes negative supply, thereby eliminating the necessity for external biasing components in many applications. The output voltage range also includes negative power supply voltage.

Application areas include transducer amplifiers, DC gain blocks and all the conventional op-amp circuits which now can be more easily implemented in single power supply systems. For example, the GM324 can be directly operated of the standard +5V power supply voltage which is used in digital systems and will easily provide the required interface electronics without requiring the additional $\pm 15V$ power supplies.

The GM324 is available in DIP-14 and SOP-14 packages.

Features

- ◆ Internal frequency compensated for unity gain
- ◆ Large DC voltage gain 100 dB
- ◆ Wide bandwidth (unity gain) 1MHz (Temperature compensated)
- ◆ Power Supply Range: Single supply 3V to 32V
- ◆ Very low supply current drain (700 μA)- essentially independent of supply voltage
- ◆ Low input biasing current 45 nA (temperature compensated)
- ◆ Low input offset voltage 2 mV and offset current: 5 nA Load Regulation 0.4% max.
- ◆ Input common-mode voltage range includes ground
- ◆ Differential input voltage range equal to the power supply voltage
- ◆ Large output voltage swing 0V to $V_{CC} - 1.5V$

Connection Diagram

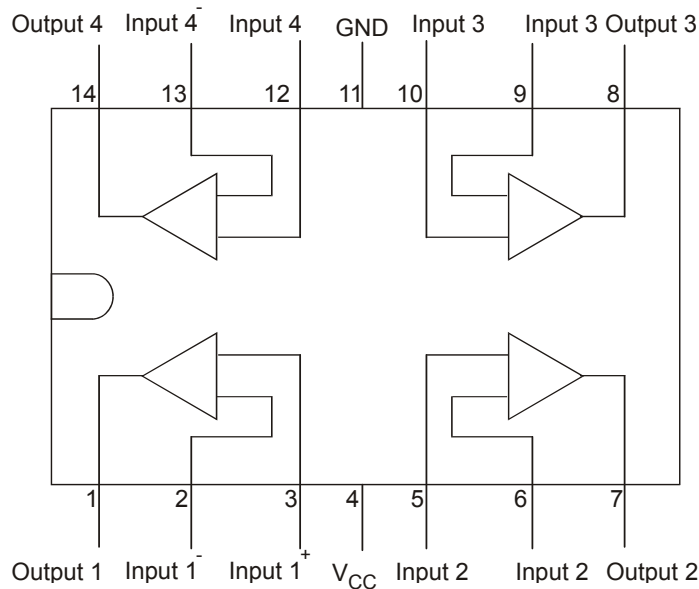

Marking Information and Pin Configurations (Top View)

SO14 and DIP14

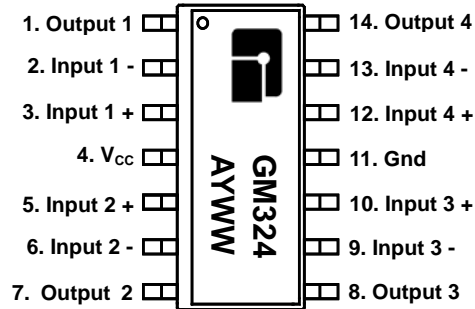

A: Assembly / Test site code

Y: Year

WW: Week

Ordering Information

Ordering Number	Package	Shipping
GM324S14T	SO14	50 Units/Tube
GM324S14R	SO14	2500 Units/Reel
GM324D14T	DIP14	25 Units/Tube

Absolute Maximum Ratings

PARAMETER	RATINGS	UNITS
Supply Voltage	± 15 or 30	V
Differential Input Voltage	± 32	V
Input Current	50	mA
Input Voltage	-0.3 to +32	V
Power dissipation	800	mW
Operating Temperature Range	0 to 70	$^{\circ}\text{C}$
Storage Temperature	- 65 to 150	$^{\circ}\text{C}$
Lead Temperature (soldering 10 sec.)	260	$^{\circ}\text{C}$

Block Diagram

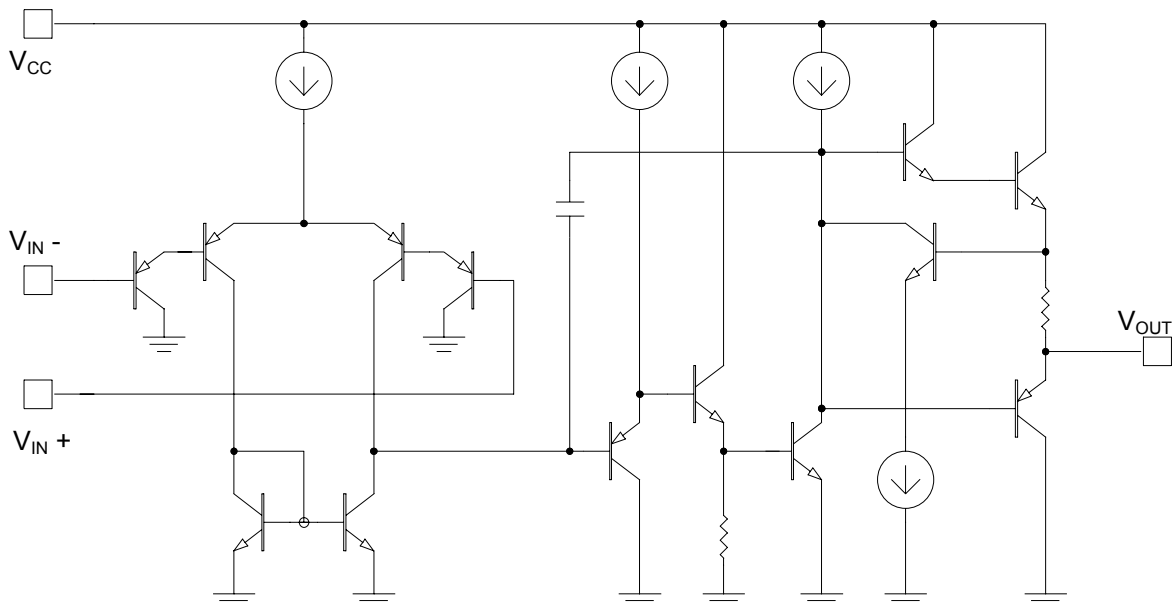

Electrical Characteristics ($V_{CC} = 5V$, at specified free-air temperature, unless otherwise specified)

Parameter	Symbol	Condition	Min	Typ	Max	Unit	
Input offset Voltage	V_{IO}	$V_{CC} = 5V$ to Max $V_{IC} = V_{ICR}$ min $V_O = 1.4V$	$T_A = 25^\circ C$		3	7	mV
			Full Range			9	
Average Temperature Coefficient of Input offset Voltage	αV_{IO}		Full Range		7		$\mu V/^\circ C$
Input Offset Current	I_{IO}		$T_A = 25^\circ C$		2	50	nA
			Full Range			150	
Average Temperature Coefficient of Input offset Current	αI_{IO}		Full Range		10		$pA/^\circ C$
Input Bias Current	I_{IB}	$V_O = 1.4V$	$T_A = 25^\circ C$		-20	-250	nA
			Full Range			-500	
Common-Mode Input Voltage Range	V_{ICR}	$V_{CC} = 5V$ to Max	$T_A = 25^\circ C$	0 to $V_{CC}-1.5V$			V
			Full Range	0 to $V_{CC}-2.0V$			
High-Level output Voltage	V_{OH}	$R_L = 2K$	$T_A = 25^\circ C$	$V_{CC}-1.5V$	-	-	V
		$V_{CC} = MAX, R_L = 2K$	Full Range	26			
		$V_{CC} = MAX, R_L = 10K$	Full Range	27	28		
Low-Level output Voltage	V_{OL}	$R_L = 10K$	Full Range		5	20	mV
Large-Signal Differential Voltage Amplification	A_{VD}	$V_{CC} = 15V,$ $V_O = 1V$ to $11V$ $R_L \geq 2K$	$T_A = 25^\circ C$	25	100		V/mV
			Full Range	15			
Common Mode Rejection Ratio	CMRR	$V_{CC} = 5V$ to Max $V_{IC} = V_{ICR}$ min	$T_A = 25^\circ C$	65	80		dB
Supply Voltage Rejection Ratio	K_{SVR}	$V_{CC} = 5V$ to Max	$T_A = 25^\circ C$	65	100		dB
Crosstalk Attenuation	V_{O1}/V_{O2}	$f = 1KHz$ to $20KHz$	$T_A = 25^\circ C$		120		dB
Output Current	I_O	$V_{CC} = 15V, V_{ID} = 1V,$ $V_O = 0V$	$T_A = 25^\circ C$	-20	-30		mA
			Full Range	-10			
		$V_{CC} = 15V, V_{ID} = -1V,$ $V_O = 15V$	$T_A = 25^\circ C$	10	20		mA
			Full Range	5			
		$V_{ID} = -1V, V_O = 200mV$	Full Range	12	30		μA
Short-Circuit output Current	I_{OS}	V_{CC} at $5V, Gnd$ at $-5V,$ $V_O = 0V$	$T_A = 25^\circ C$		± 40	± 60	mA
Supply Current (four amplifiers)	I_{CC}	$V_O = 2.5V, No$ Load	Full Range		1.5	2.4	mA
		$V_{CC} = Max,$ $V_O = 0.5V_{CC}, No$ Load	Full Range		1.1	3	

All characteristics are measured under open loop conditions with zero common-mode input voltage unless otherwise specified.
"MAX" V_{CC} for testing purposes is 30V. Full range is $0^\circ C$ to $70^\circ C$.

Typical Performance Characteristics

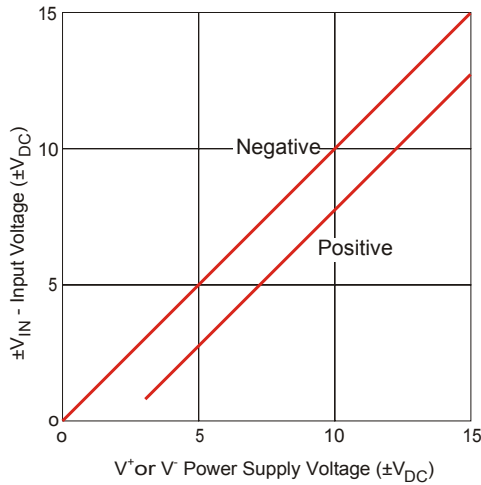

Figure 1. Input Voltage Range

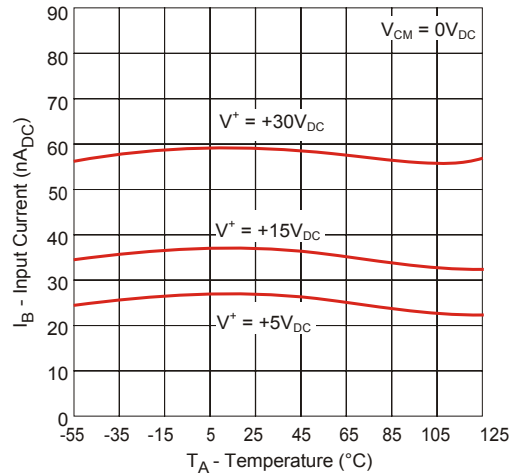

Figure 2. Input Current

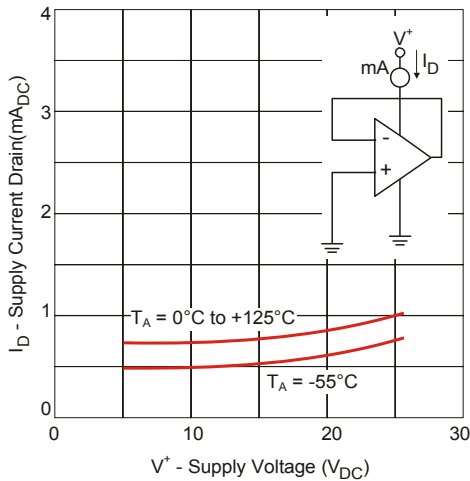

Figure 3. Supply Current

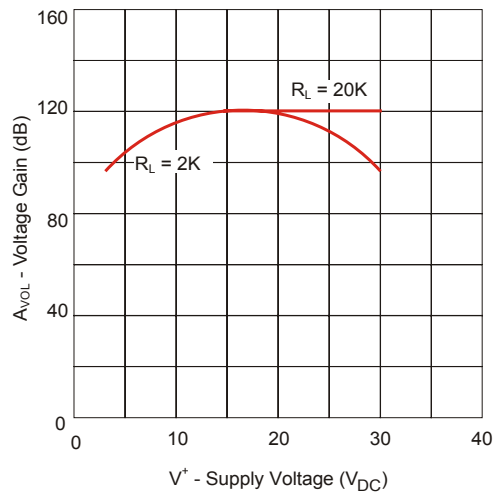

Figure 4. Voltage Gain

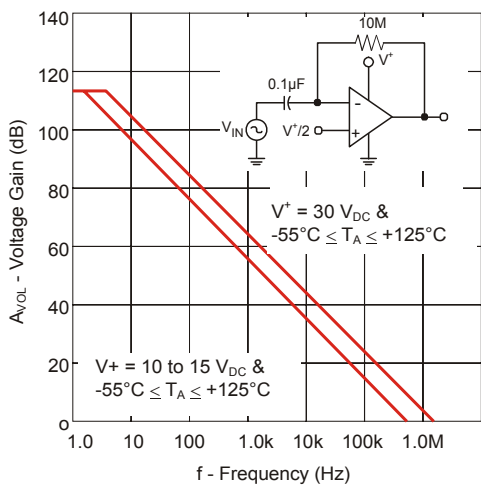

Figure 5. Open Loop Frequency Response

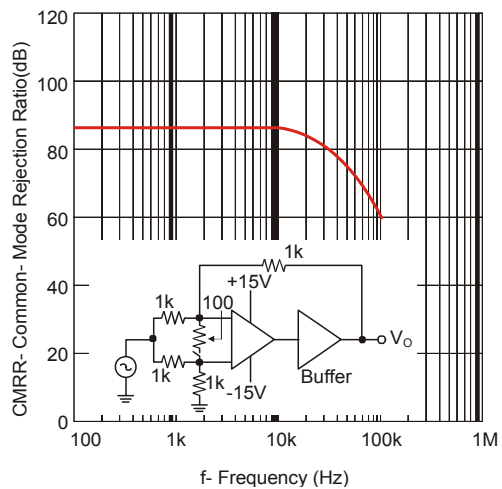

Figure 6. Common Mode Rejection Ratio

Typical Performance Characteristics (continued)

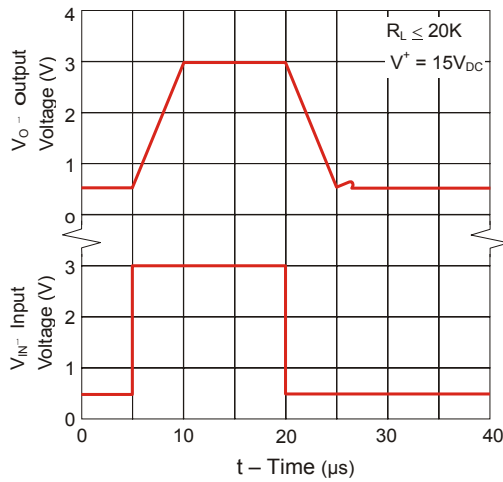

Figure 7. Voltage Follower Pulse Response

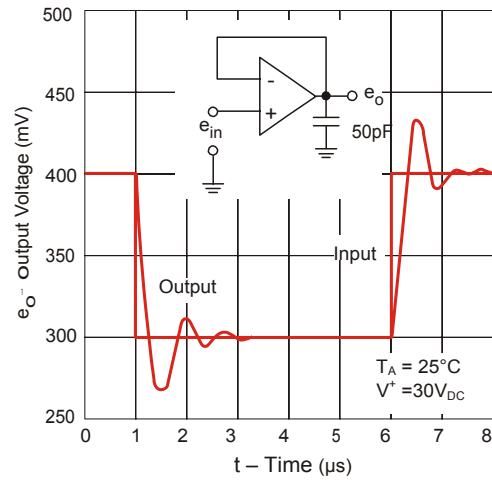

Figure 8. Voltage Follower Pulse Response (Small Signal)

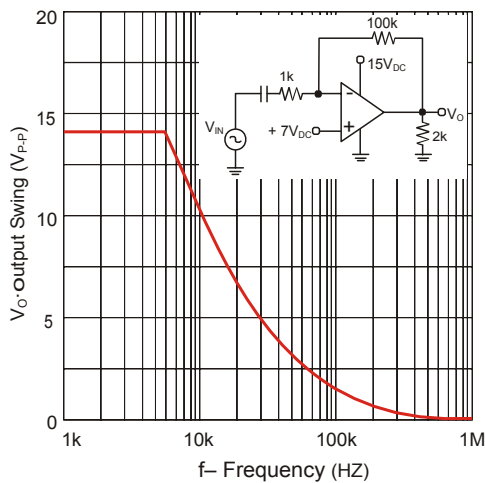

Figure 9. Large Signal Frequency Response

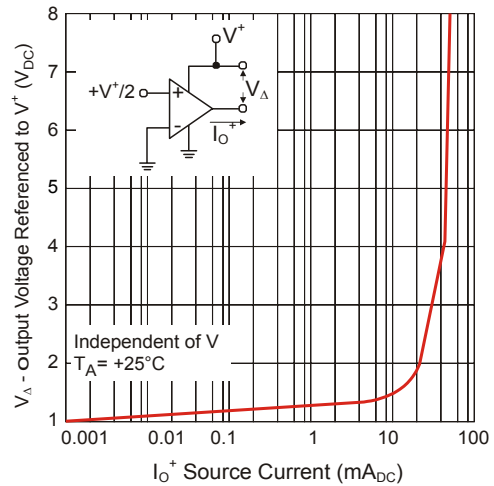

Figure 10. Output Characteristics Current Sourcing

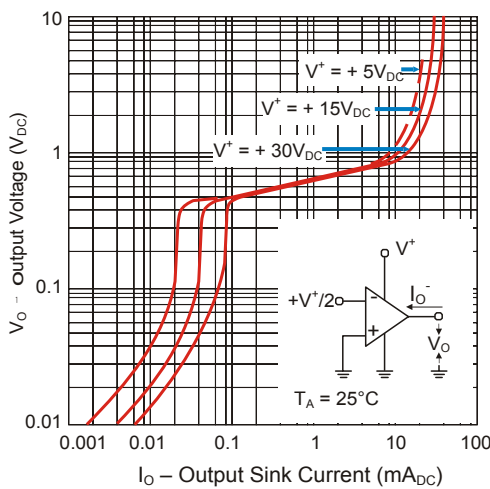

Figure 11. Output Characteristics Current Sinking

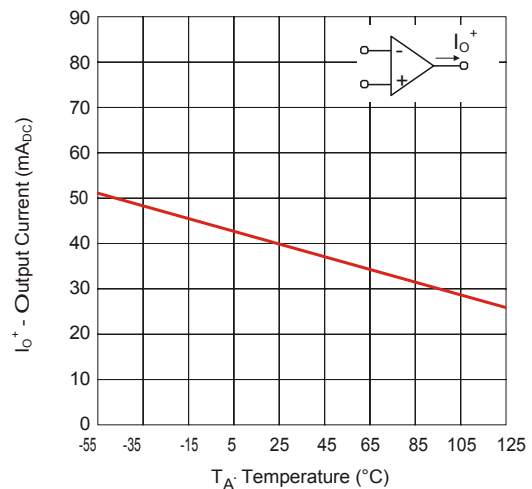
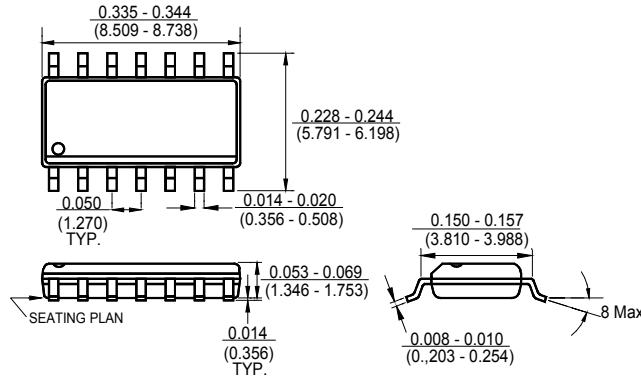
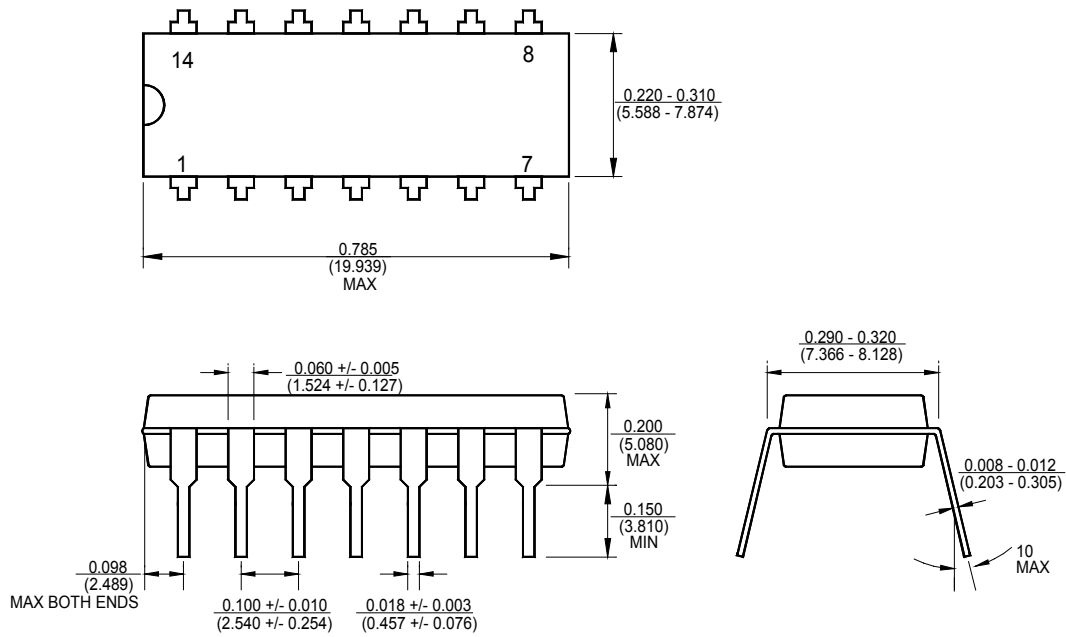

Figure 12. Current Limiting

Package Outline Dimensions – SO 14



Package Outline Dimensions – DIP 14



Ordering Number

GM 324 S14 R

APM Gamma Micro	Circuit Type	Package Type	Shipping Type
		S14: SO 14 D14: DIP 14	R: Taping & Reel T: Tube

Note:

Pb-free products:

- ◆ RoHS compliant and compatible with the current requirements of IPC/JEDEC J-STD-020.
- ◆ Suitable for use in Pb-free soldering processes with 100% matte tin (Sn) plating.

Green products:

- ◆ Lead-free (RoHS compliant)
- ◆ Halogen free (Br or Cl does not exceed 900ppm by weight in homogeneous material and total of Br and Cl does not exceed 1500ppm by weight)