

Description

The GM358 consists of two high gain, internally frequency compensated operational amplifiers which are designed to operate from a single power supply over a wide range of voltages. Operation from split power supplies is also available. The GM358 features low power drain, a common mode input voltage range extending to GND/VEE. The GM358 is equivalent to one-half of the GM324.

Application areas include transducer amplifiers, DC gain blocks and all the conventional op-amp circuits which now can be more easily implemented in single power supply systems. For example, the GM358 can be directly operated from the standard +5V power supply voltage which is used in digital systems and will easily provide the required interface electronics without requiring the additional $\pm 15V$ power supplies.

The GM358 is available in SOP-8 and DIP-8 packages.

Features

- ◆ True Differential Input Stage
- ◆ Internally Frequency Compensated for Unity Gain
- ◆ Single Supply Operation: 3V to 40V
- ◆ Wide Bandwidth (unity Gain, temperature compensated): 1 MHz
- ◆ Short Circuit Protected Outputs
- ◆ Low Input Bias Current
- ◆ Common Mode Range Extends to Negative Supply
- ◆ Single and Split Supply Operation

Typical Application Circuits

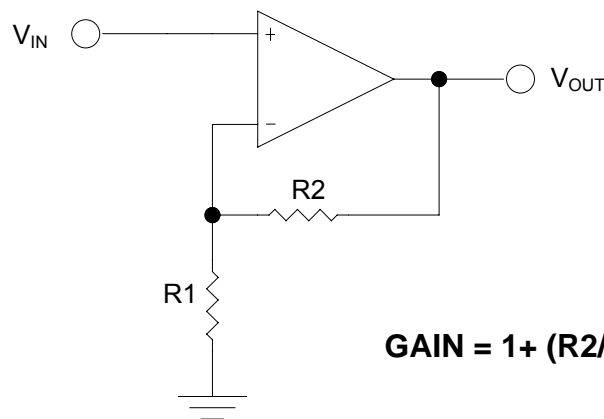

Marking Information and Pin Configurations (Top View) – Pb Free

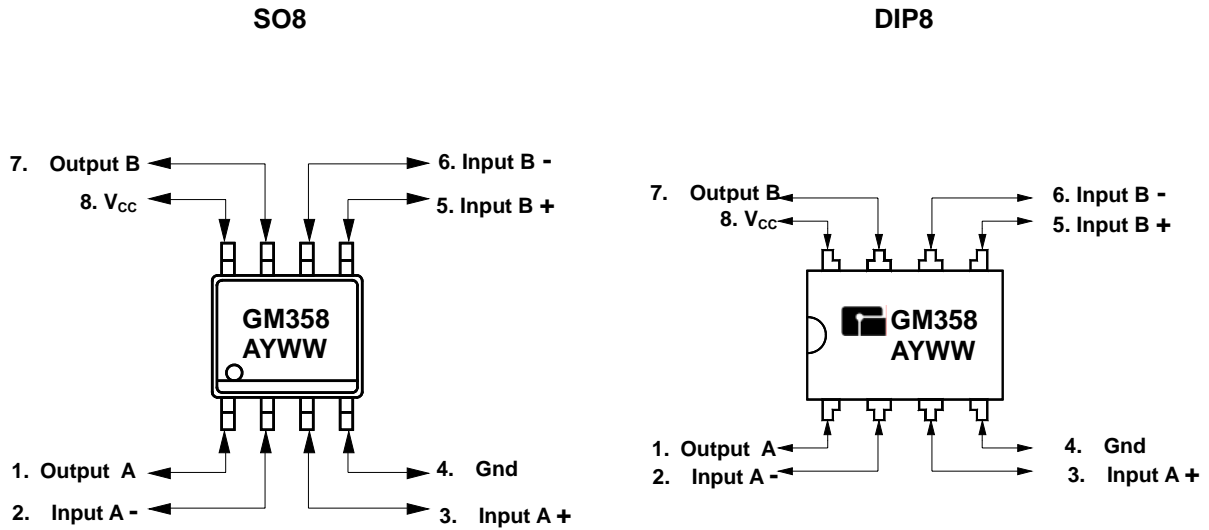

A: Assembly / Test site code
Y: Year
WW: Week

Marking Information and Pin Configurations (Top View) – Green

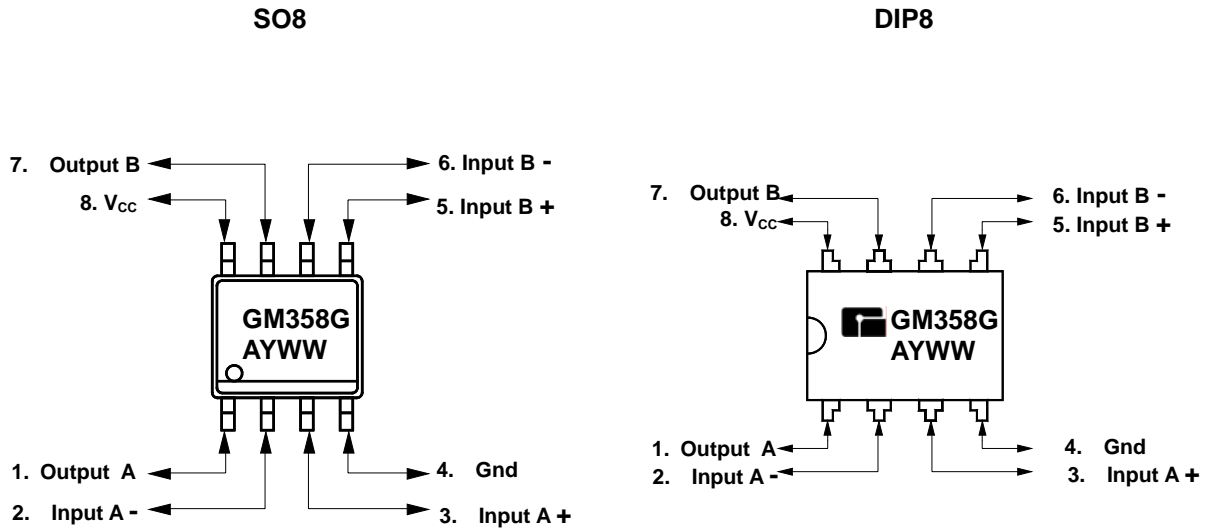

G: Green Product
A: Assembly / Test site code
Y: Year
WW: Week

Ordering Information – Pb Free Product

Ordering Number	Package	Shipping
GM358D8T	DIP-8	60 Units / Tube
GM358S8T	SOP-8	100 Units / Tube
GM358S8R	SOP-8	2,500 Units / Tape & Reel

Ordering Information – Green Product

Ordering Number	Package	Shipping
GM358D8TG	DIP-8	60 Units / Tube
GM358S8TG	SOP-8	100 Units / Tube
GM358S8RG	SOP-8	2,500 Units / Tape & Reel

Absolute Maximum Ratings

PARAMETER	Symbol	RATINGS	UNITS
Supply Voltage	V_{CC}	32	V
	V_{CC}, V_{EE}	± 16	
Input Differential Voltage Range (Note 1)	V_{IDR}	32	V
Input Common Mode Voltage Range (Note 2)	V_{ICR}	$=0.3$ to 32	V
Output Short Circuit Duration	t_{SC}	Continuous	-
Junction Temperature	T_J	150	$^{\circ}C$
Operating Ambient Temperature Range	T_A	0 to 70	$^{\circ}C$
Storage Temperature		- 65 to 150	$^{\circ}C$
Lead Temperature (soldering 10 sec.)		260	$^{\circ}C$
ESD Tolerance – Human Body Mode		2,000	V

Note 1: Split Power Supplies

Note 2: For Supply less 40V, the absolute maximum input range is equal to the supply voltage

Block Diagram

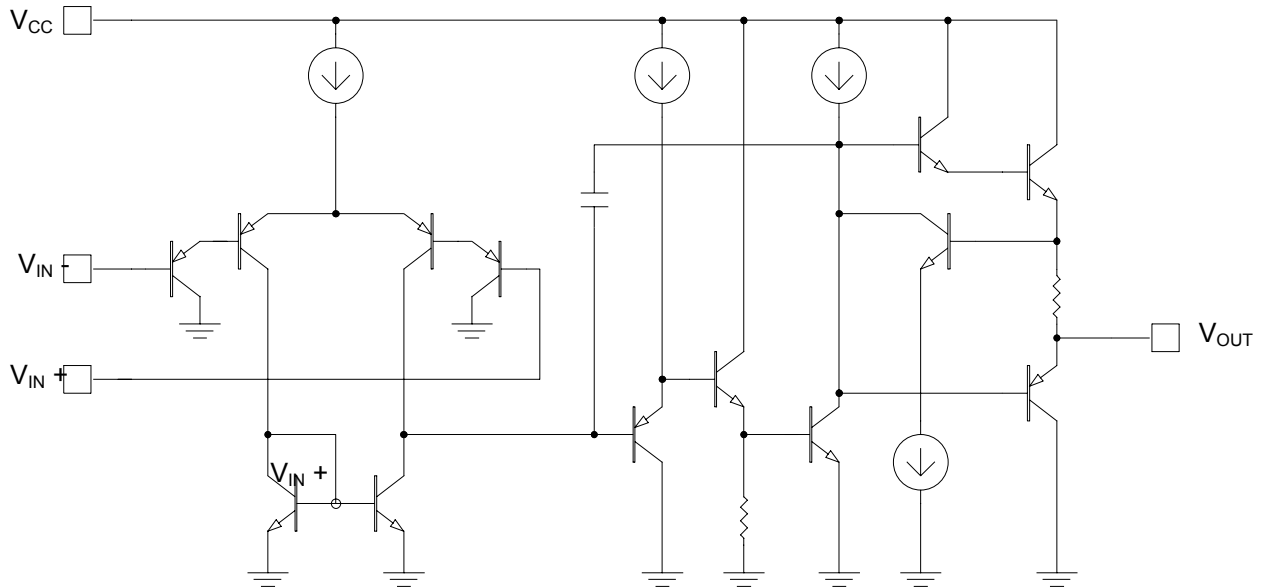

Electrical Characteristics ($V_{CC} = 5V$, at specified free-air temperature, unless otherwise specified)

Parameter	Symbol	Condition	Min	Typ	Max	Unit	
Input offset Voltage	V_{IO}	$V_{CC} = 5V$ to Max $V_{IC} = V_{ICR}$ min $V_O = 1.4V$	$T_A = 25^\circ C$		3	7	mV
			Full Range			9	
Average Temperature Coefficient of Input offset Voltage	αV_{IO}		Full Range		7		$\mu V/^\circ C$
Input Offset Current	I_{IO}		$T_A = 25^\circ C$		2	50	nA
			Full Range			150	
Average Temperature Coefficient of Input offset Current	αI_{IO}		Full Range		10		$pA/^\circ C$
Input Bias Current	I_{IB}	$V_O = 1.4V$	$T_A = 25^\circ C$		-20	-250	nA
			Full Range			-500	
Common-Mode Input Voltage Range	V_{ICR}	$V_{CC} = 5V$ to Max	$T_A = 25^\circ C$	0 to $V_{CC}-1.5V$			V
			Full Range	0 to $V_{CC}-2.0V$			
High-Level output Voltage	V_{OH}	$R_L = 2K$	$T_A = 25^\circ C$	$V_{CC}-1.5V$	-	-	V
		$V_{CC} = MAX, R_L = 2K$	Full Range	26			
		$V_{CC} = MAX, R_L = 10K$	Full Range	27	28		
High-Level output Voltage	V_{OL}	$R_L = 10K$	Full Range		5	20	mV
Large-Signal Differential Voltage Amplification	A_{VD}	$V_{CC} = 15V,$ $V_O = 1V$ to $11V$ $R_L \geq 2K$	$T_A = 25^\circ C$	25	100		V/mV
			Full Range	15			
Common Mode Rejection Ratio	CMRR	$V_{CC} = 5V$ to Max $V_{IC} = V_{ICR}$ min	$T_A = 25^\circ C$	65	80		dB
Supply Voltage Rejection Ratio	K_{SVR}	$V_{CC} = 5V$ to Max	$T_A = 25^\circ C$	65	100		dB
Crosstalk Attenuation	V_{O1}/V_{O2}	$f = 1KHz$ to $20KHz$	$T_A = 25^\circ C$		120		dB
Output Current	I_O	$V_{CC} = 15V, V_{ID} = 1V,$ $V_O = 0V$	$T_A = 25^\circ C$	-20	-30		mA
			Full Range	-10			
			$T_A = 25^\circ C$	10	20		
			Full Range	5			
		$V_{ID} = -1V, V_O = 200mV$	Full Range	12	30		μA
Short-Circuit output Current	I_{OS}	V_{CC} at $5V, Gnd$ at $-5V,$ $V_O = 0V$	$T_A = 25^\circ C$		± 40	± 60	mA
Supply Current (two amplifiers)	I_{CC}	$V_O = 2.5V, No$ Load	Full Range		0.7	1.2	mA
		$V_{CC} = Max,$ $V_O = 0.5V_{CC}, No$ Load	Full Range		1	2	

* All characteristics are measured under open loop conditions with zero common-mode input voltage unless otherwise specified. "MAX" V_{CC} for testing purposes is 30V.

Typical Performance Characteristics

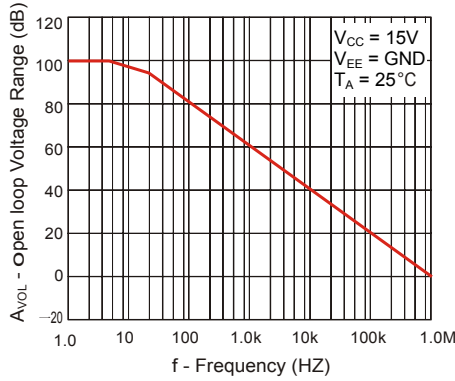

Figure 1. Large-Signal Open Loop Voltage Gain

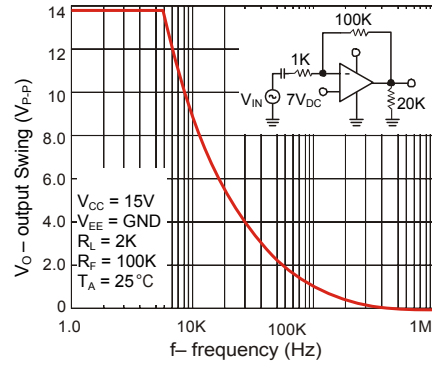

Figure 2. Large-Signal Frequency Response

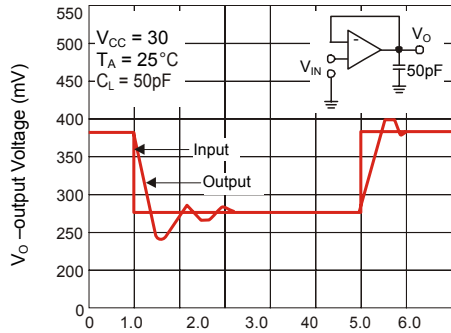

Figure 3. Small Signal Voltage Follower Pulse Response (Noninverting)

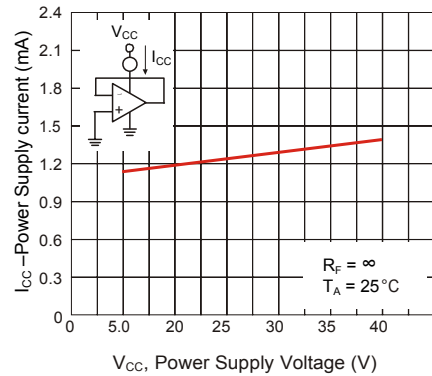

Figure 4. Power Supply Current versus Power Supply Voltage

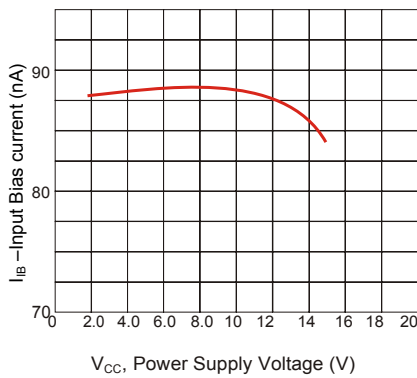

Figure 5. Input Bias Current versus Supply Voltage

Application Information

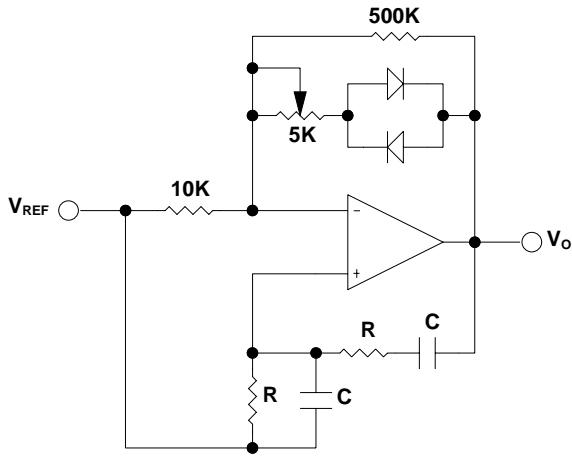

Fig.1 Wien Bridge Oscillator

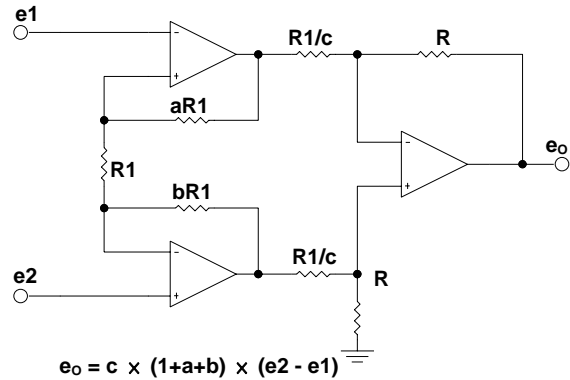

Fig. 2 High Impedance Differential Amplifier

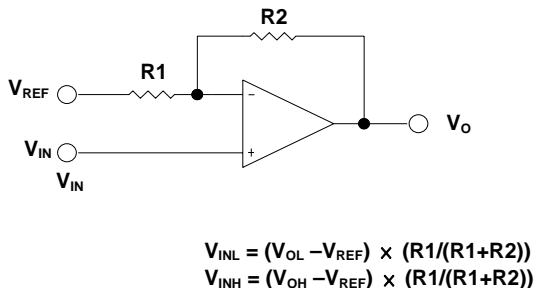

Fig. 3 Comparator with Hysteresis

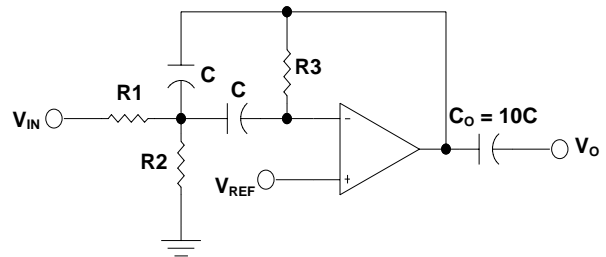

Fig. 4 Multiple Feedback Bandpass Filter

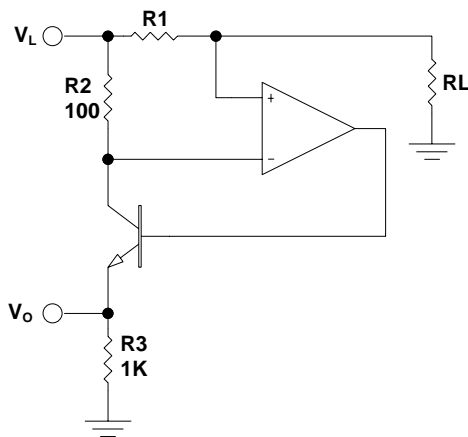

Fig. 5 Current Monitor

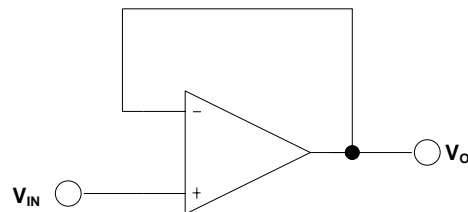
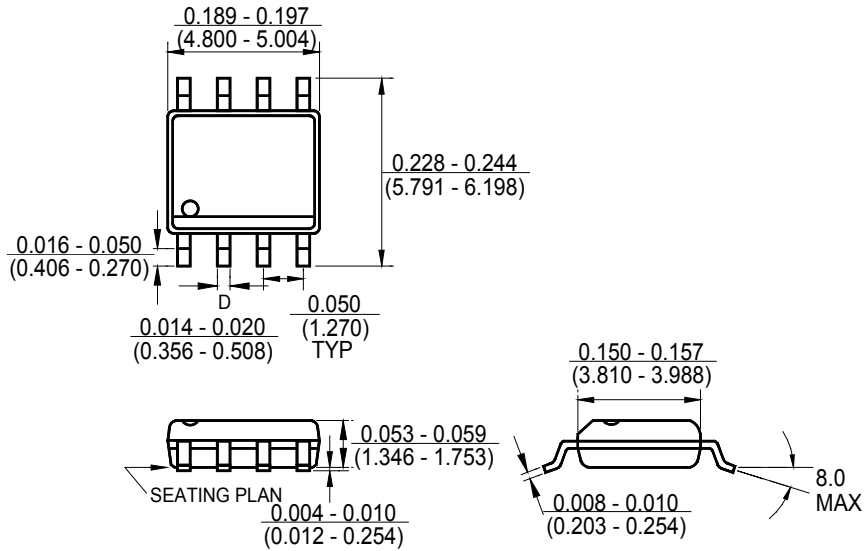
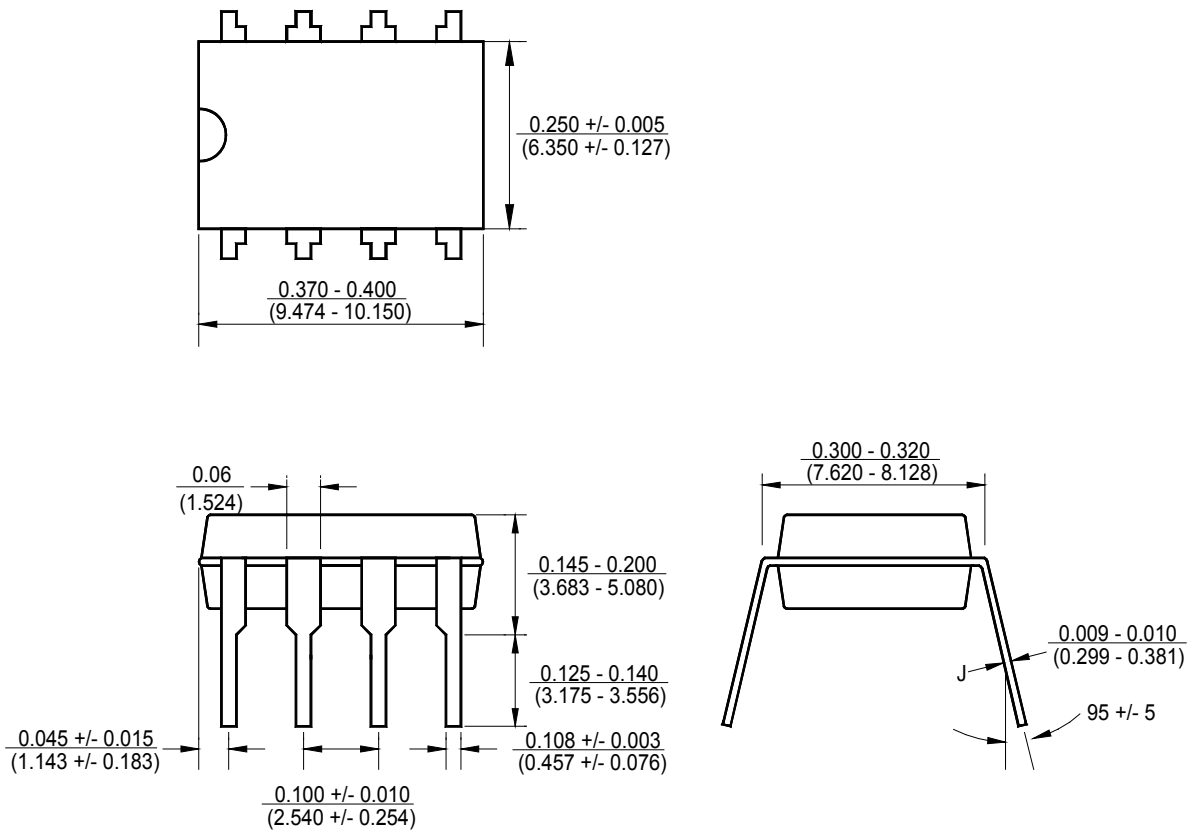

Fig. 6 Voltage Follower

Package Outline Dimensions – SO 8



Package Outline Dimensions – DIP 8



Ordering Number

<u>GM</u>	<u>358</u>	<u>S8</u>	<u>R</u>	<u>G</u>
APM Gamma Micro	Circuit Type	Package Type S8: SO 8 D8: DIP 8	Shipping Type R: Taping & Reel T: Tube	Blank :Pb-free G :Green

Note:

Pb-free products:

- ◆ RoHS compliant and compatible with the current requirements of IPC/JEDEC J-STD-020.
- ◆ Suitable for use in Pb-free soldering processes with 100% matte tin (Sn) plating.

Green products:

- ◆ Lead-free (RoHS compliant)
- ◆ Halogen free (Br or Cl does not exceed 900ppm by weight in homogeneous material and total of Br and Cl does not exceed 1500ppm by weight)