

Description

The GM317 is an adjustable 3-terminal positive voltage regulator capable of supplying in excess of 1.5 A over an output voltage range of 1.2 V to 37 V. This voltage regulator is exceptionally easy to use and requires only two external resistors to set the output voltage. Further, it employs internal current limiting, thermal shutdown and safe area compensation, making it essentially blow out proof.

GM317 offers full overload protection. Included on the chip current limit, thermal overload protection, and safe-area protection. Normally, no capacitors is needed unless the device is situated far from the input filter capacitors in which case an input bypass is needed. An optional output capacitor can added to improve transient response.

Features

- Output current up to 1.5A
- Output Voltages 1.2V to 37V
- Input Regulation typ. 0.01%
- Output Regulation typ. 0.1%
- Peak Output Current Constant over Temperature Range of Regulator
- Available in TO-220, TO-263, TO252 and SOT223 Packages
- Ripple Rejection Typically 80dB
- Direct replacements for LM317

Applications

- Voltage Regulators
- Power Supplies
- Current Regulators
- Switching Regulators
- Current Limiter
- Constant Current Battery Charger
- Current Limited Charger

Typical Application Circuit

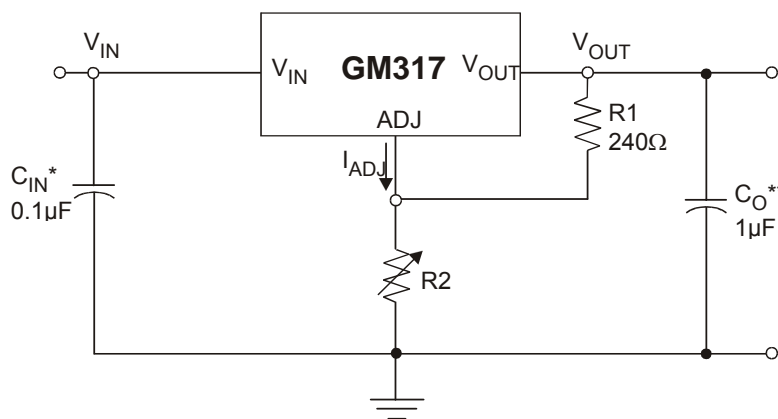

* C_{IN} is required if regulator is located an appreciable distance from power supply filter.

** C_O 's not needed for stability, however, it improve transient response.

$$V_{OUT} = 1.25V \left(1 + \frac{R2}{R1}\right) + I_{ADJ}R2$$

Since I_{ADJ} is controlled to less than 100µA, the error associated with this term is negligible in most applications.

Marking Information and Pin Configurations (Top View)

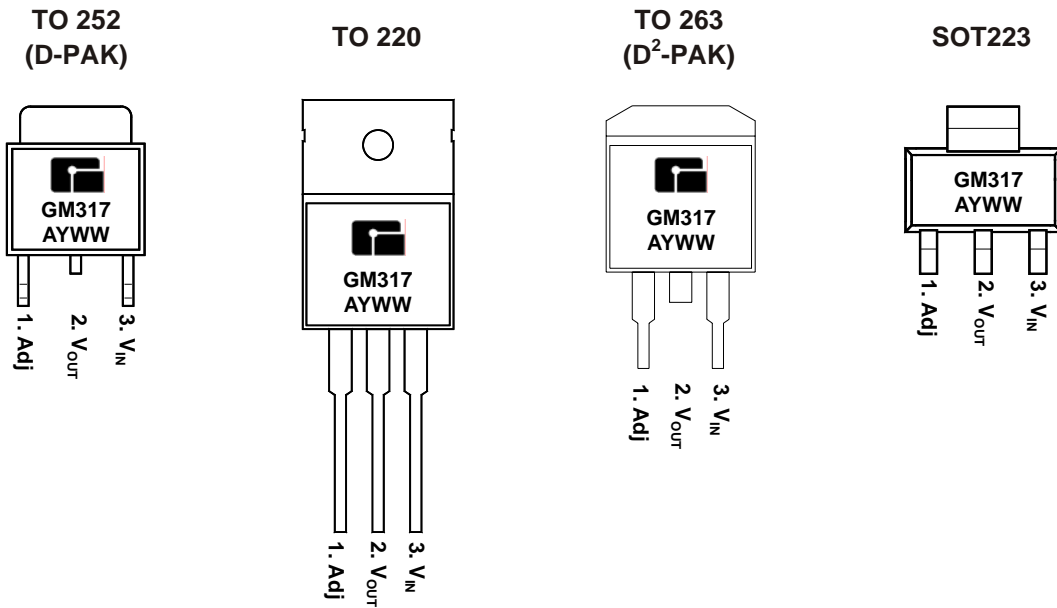

A: Assembly / Test site code
Y: Year
WW: Week

Ordering Information

Ordering Number	V _{OUT}	Package	Shipping
GM317TA3T	Adj	TO-263	50 Units/Tube
GM317TA3R		TO-263	800 Units / Tape & Reel
GM317TB3T		TO-220	50 Units/Tube
GM317TC3T		TO-252	80 Units/Tube
GM317TC3R		TO-252	2,500 Units / Tape & Reel
GM317ST3T		SOT-223	80 Units/Tube
GM317ST3R		SOT-223	2,500 Units / Tape & Reel

Absolute Maximum Ratings

PARAMETER		RATINGS	UNITS
Input Voltage, V_I		41	V
Input to Output Differential Voltage, $V_I - V_O$		40	V
Continuous Total Dissipation at 25°C Free-air Temperature		2	W
Continuous Total Dissipation at (or below) 25°C Cast Temperature		15	
Operating Junction Temperature	T_J	0 to 125	°C
Storage Temperature	T_{stg}	- 60 to 150	°C
Lead Temperature 1.6mm (1/6 inch) from case for 10 seconds		260	°C

Recommended Operating Conditions

PARAMETER	Min	Max	Unit
Output Current, I_O	10	1500	mA
Operating Virtual Junction Temperature, T_J	0	125	°C

Block Diagram

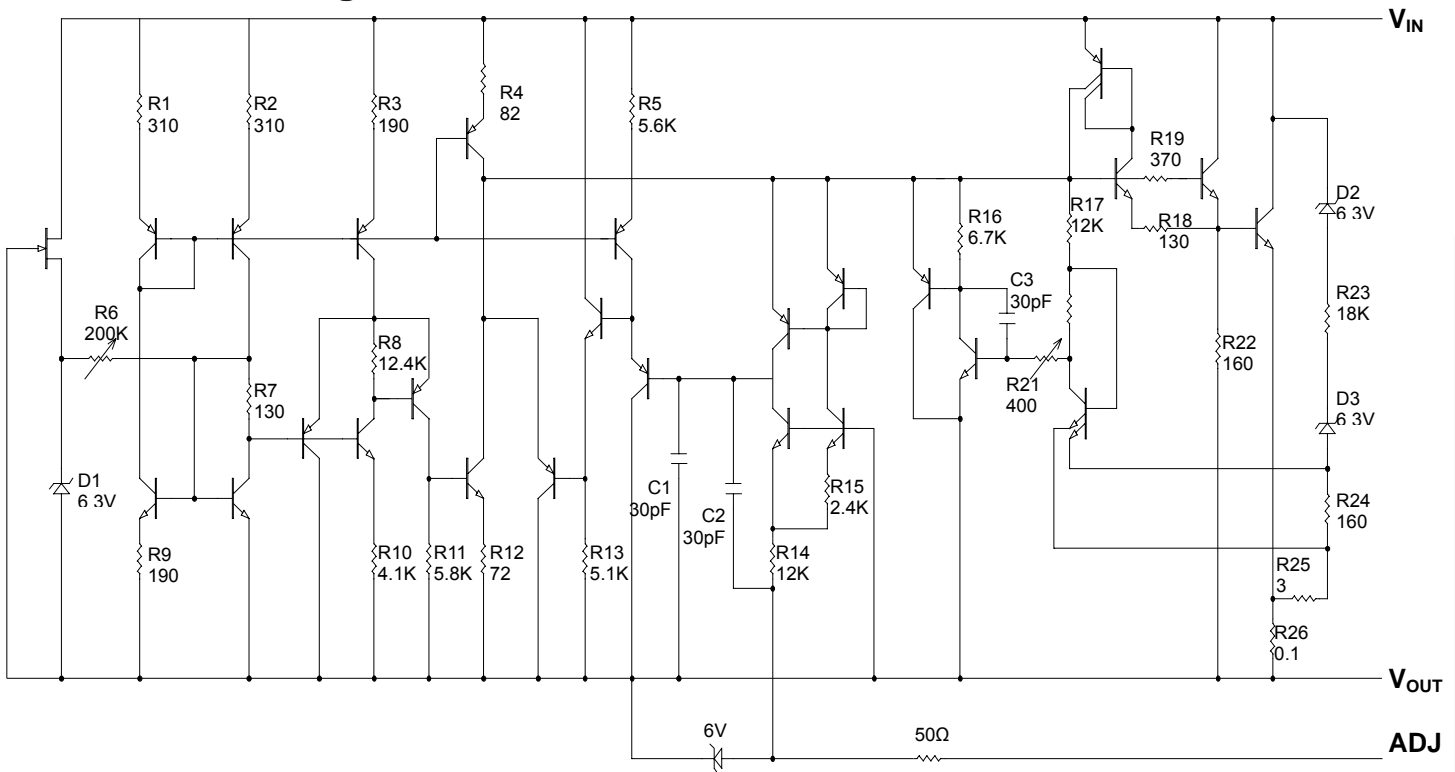

Electrical Characteristics (Unless otherwise noted, $V_I - V_O = 5V$ and $I_O = 0.5A$. $T_J = \text{Full Range}$, unless otherwise noted)

Parameter	Symbol	Test Condition	Min	Typ	Max	Unit	
Line Regulation (note 2)	ΔV_{OI}	$3V \leq V_{IN} - V_{OUT} \leq 40V, T_J = 25^\circ C$		0.01	0.04	%V	
		$3V \leq V_{IN} - V_{OUT} \leq 40V,$		0.02	0.07		
Ripple Rejection Ratio		$V_{OUT} = 10V, f = 120Hz$		65		dB	
		$V_{OUT} = 10V, f = 120Hz, 10\mu F$ capacitor between ADJ and GND	66	80			
Load regulation (note 3)	ΔV_{OL}	$10mA \leq I_{OUT} \leq 1.5A,$ $T_J = 25^\circ C$	$V_O \leq 5V$		5	25	mV
			$V_O > 5V$		0.1	0.5	%
		$10mA \leq I_{OUT} \leq 1.2A$	$V_O \leq 5V$		20	70	mV
			$V_O > 5V$		0.3	1.5	%
Output Voltage Change with Temperature	ΔV_{OT}	Full Temperature Range				%	
Long Term Stability (Note 4)		$T_J = 125^\circ C, V_{IN} - V_{OUT} = 40V,$ after 1000hr		0.3	1	%	
Output Noise Voltage		$10Hz \leq f \leq 10KHz, T_J = 25^\circ C$		0.003		%	
Minimum Load Current		$V_{IN} - V_{OUT} \leq 40V$		3.5	10	mA	
Output Current Limit	I_{CL}	$V_{IN} - V_{OUT} \leq 15V$	1.5	2.2		A	
		$V_{IN} - V_{OUT} \leq 40V, T_J = 25^\circ C$	0.15	0.4			
Adjustment Pin Current	I_{ADJ}			50	100	μA	
Adjustment Pin Current Change	ΔI_{ADJ}	$3V \leq V_{IN} - V_{OUT} \leq 40V$ $10mA \leq I_{OUT} \leq 1.2A$		0.2	5.0	μA	
Reference Voltage		$3V \leq V_{IN} - V_{OUT} \leq 40V,$ $10mA \leq I_{OUT} \leq 1.5A, P \leq 15W$	1.2	1.25	1.3	V	

Note 1: All characteristics are measured with a 0.1 μF capacitor across the input and a 1 μF capacitor across the output.

Note 2: Input regulation is expressed here as the percentage change in output voltage per 1V change at the input.

Note 3: Pulse testing techniques are used to maintain the junction temperature as close to the ambient temperature as possible. Thermal effects must be taken into account separately.

Note 4: Since long-term drift cannot be measured on the individual devices prior to shipment, this specification is not intended to be a guarantee or warranty. It is an engineering estimate of the average drift to be expected from lot to lot.

Application Information

Basic Circuit Operation

The GM317 is a 3-terminal floating regulator. In operation, the GM317 develops and maintains a nominal 1.25V reference (V_{REF}) between its output and adjustment terminals. This reference voltage is converted to a programming current flow through R2 to ground.

The regulated output voltage is given by:

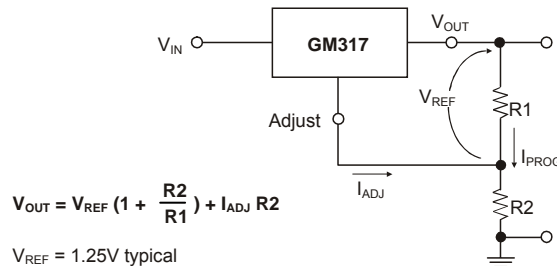

Basic Circuit Configuration

Since the current from the adjustment terminal (I_{ADJ}) represents an error term in the equation, the GM317 was designed to control I_{ADJ} to less than 100 μ A and keep it constant. To do this, all quiescent operating current is returned to the output terminal. This imposes the requirement for a minimum load current. If the load current is less than this minimum, the output voltage will rise.

Since the GM317 is a floating regulator, it is only the voltage differential across the circuit which is important to performance, and operation at high voltages with respect to ground is possible.

Load Regulation

The GM317 is capable of providing extremely good load regulation, but a few precautions are needed to obtain maximum performance. For best performance, the programming resistor R1 should be connected as close to the regulator as possible to minimize line drops which effectively appear in series with the reference, thereby degrading regulation. The ground end of R2 can be returned near the load ground to provide remote ground sensing and improve load regulation.

External Capacitors

A 0.1 μ F disc or 1.0 μ F tantalum input bypass capacitor C_{IN} is recommended to reduce the sensitivity to input line impedance. The adjustment terminal may be bypassed to ground to improve ripple rejection. This capacitor C_{ADJ} prevents ripple from being amplified as the output voltage is increased. A 10 μ F capacitor should improve ripple rejection about 15 dB at 120Hz in a 10V application.

Although the GM317 is stable with no output capacitance, like any feedback circuit, certain values of external capacitance can cause excessive ringing. An output capacitance C_O in the form of a 1.0 μ F tantalum or 25 μ F aluminum electrolytic capacitor on the output swamps this effect and insures stability.

Protection Diodes

When external capacitors are used with any IC regulator, it is sometimes necessary to add protection diodes to prevent the capacitors from discharging through low current points into the regulator.

The figure below shows the GM317 with the recommended protection diodes for output for output voltage in excess of 25V or high capacitance values ($C_O > 25\mu$ F, $C_{ADJ} > 10\mu$ F). Diode D1 prevents C_O from discharging thru the IC during an input short circuit. Diode D2 protects against capacitor C_{ADJ} discharging through the IC during an output short circuit. The combination of diodes D1 and D2 prevents C_{ADJ} from discharging through the IC during an input short circuit.

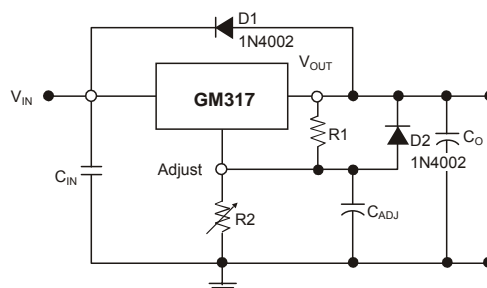

Typical Performance Characteristics

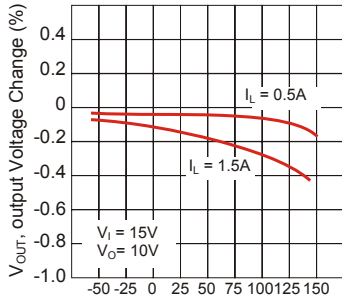

T_J , Junction Temperature ($^{\circ}C$)
Figure 1. Load Regulation

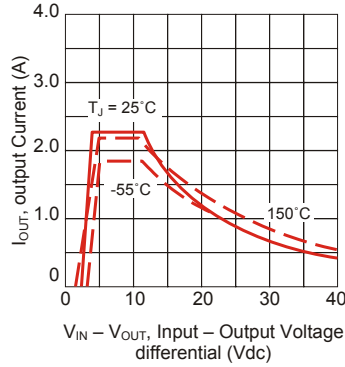
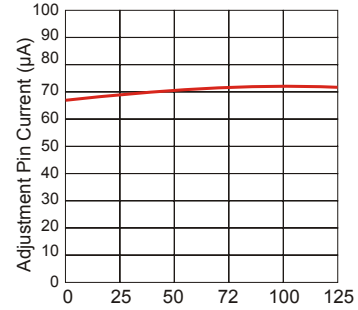
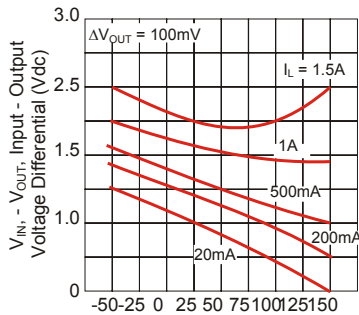

Figure 2. Current Limit



Ambient Temperature ($^{\circ}C$)
Figure 3. Adjustment Pin Current vs. Temperature



T_J , Junction Temperature ($^{\circ}C$)
Figure 4. Dropout Voltage

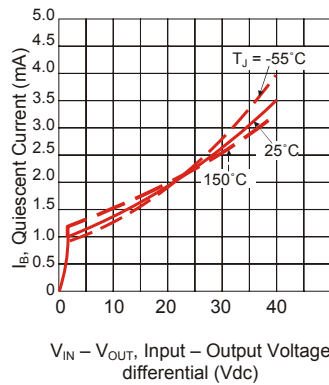
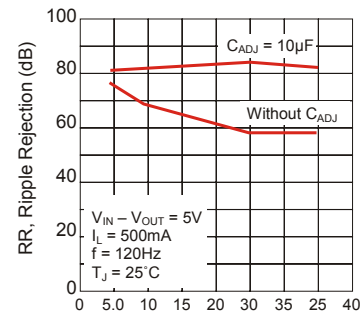
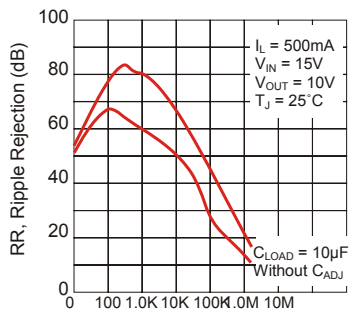

Figure 5. Minimum Operating current



V_{OUT} , Output Voltage
Figure 6. Ripple Rejection vs. Output Voltage



$V_{IN} - V_{OUT}$, Input - Output Voltage differential (Vdc)
Figure 7. Ripple Rejection vs. Frequency

Package Outline Dimensions – SOT223

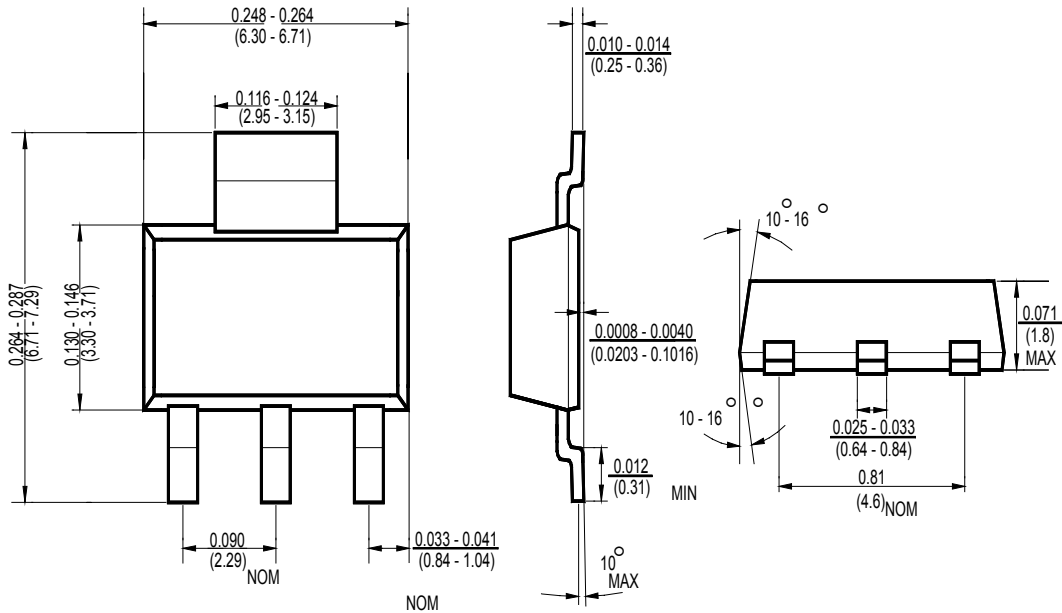

Package Outline Dimensions – TO263

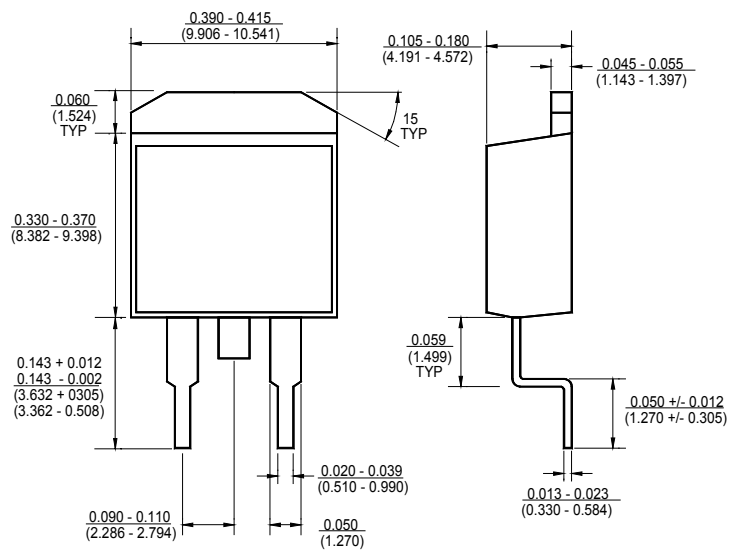

Package Outline Dimensions – TO252

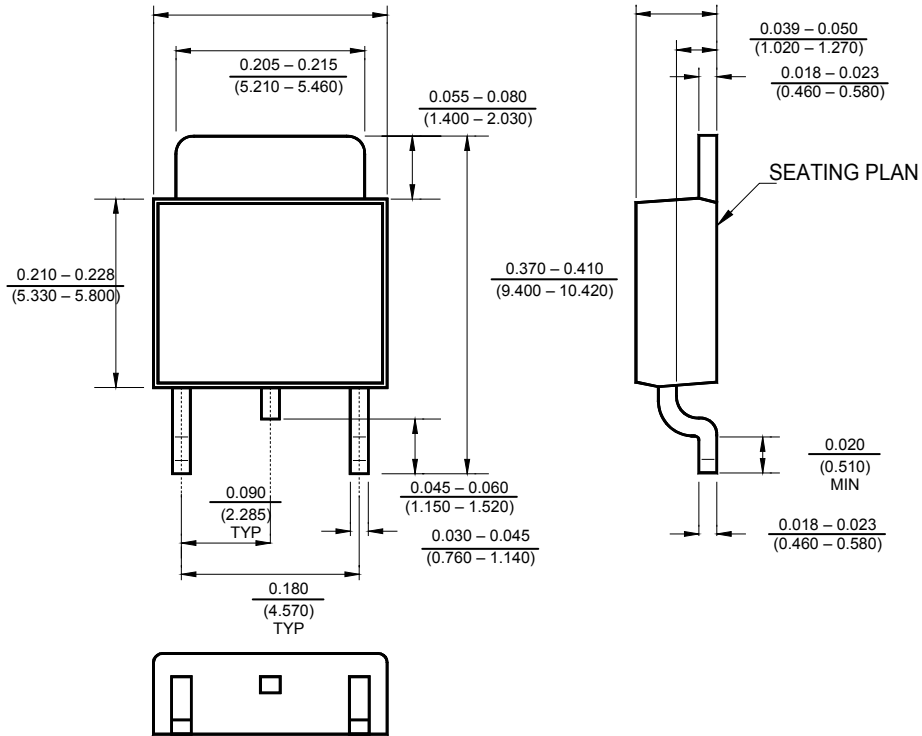

Ordering Number

GM 317 TA3 I

APM Gamma Micro	Circuit Type	Package Type	Shipping Type
		TA3: TO263 TB3: TO220 TC3: TO252 ST3: SOT223	T: Tube R: Tape & Reel

Note:

Pb-free products:

- ◆ RoHS compliant and compatible with the current requirements of IPC/JEDEC J-STD-020.
- ◆ Suitable for use in Pb-free soldering processes with 100% matte tin (Sn) plating.

Green products:

- ◆ Lead-free (RoHS compliant)
- ◆ Halogen free (Br or Cl does not exceed 900ppm by weight in homogeneous material and total of Br and Cl does not exceed 1500ppm by weight)