

THE INFORMATION CONTAINED HEREIN IS CONSIDERED "PROPRIETARY" TO BEL FUSE INC. AND SHALL NOT BE COPIED, REPRODUCED OR DISCLOSED WITHOUT THE WRITTEN APPROVAL OF BEL FUSE INC.

RoHS
2002/95/EC



LED1 POLARITY			LED2 POLARITY		
PIN 13	PIN 14	COLOR	PIN 15	PIN 16	COLOR
-	+	GREEN	-	+	GREEN

ELECTRICAL CHARACTERISTICS @ 25°C

URNS RATIO

TP1	1CT : 1CT ±2%
TP2	1CT : 1CT ±2%
TP3	1CT : 1CT ±2%
TP4	1CT : 1CT ±2%

□CL @ 100kHz/100mVRMS

8mA DC BIAS (0-70 Deg. C) 350µH MIN.

INS. LOSS

0.1MHz TO 1MHz	-1.1 dB MAX
1MHz TO 65MHz	-0.5 dB MAX
65MHz TO 100MHz	-0.8 dB MAX
100MHz TO 125MHz	-1.2 dB MAX

RET. LOSS (MIN) @ 100 OHMS +/-15%

0.5MHz-40MHz	-18 dB
40MHz-100MHz	-12+20LOG(f/80MHz) dB

CM TO CM REJ

100kHz - 100MHz	-30 dB MIN
-----------------	------------

CM TO DM REJ

100kHz - 100MHz	-35 dB MIN
-----------------	------------

HIPOT (Isolation Voltage): 1500 Vrms

100% OF PRODUCTION TESTED TO COMPLY WITH IEEE 802.3 ISOLATION REQUIREMENTS.

LED 1&2

VF (FORWARD VOLTAGE)	IF=20mA	GREEN	2.2V TYP.
λD (DOMINANT WAVELENGTH)	IF=20mA	GREEN	565nm TYP.

SCHEMATIC

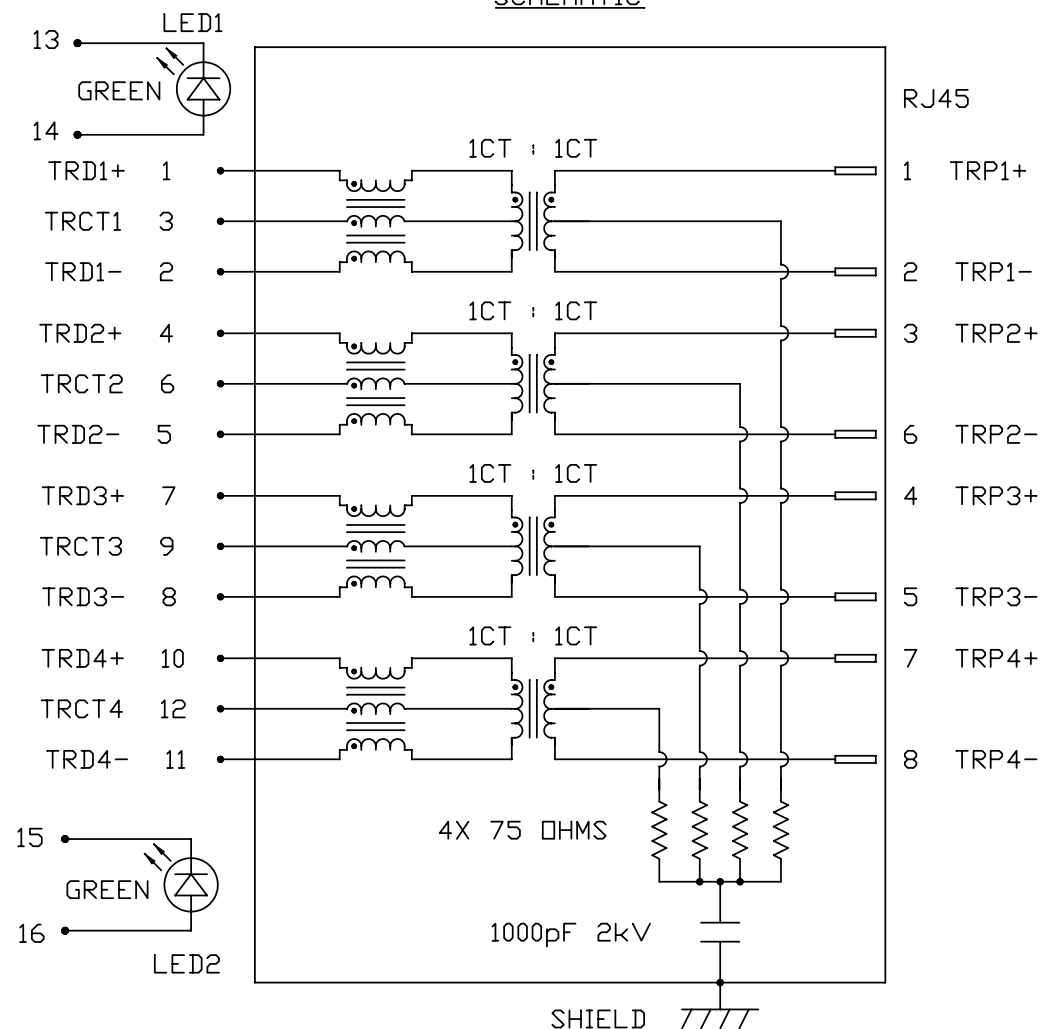

ORIGINATED BY	DATE	TITLE	PART NO. / DRAWING NO.	STANDARD DIM. TOL. IN INCH	[] METRIC DIM. AS REFERENCE
CHOW WANGCHUNG	06-07-11	Gigabit MagJack® NanoJack (50 Micro-Inch Hard Gold Plating of -BF) PATENTED	L886-1G2T-CN	.X .XX .XXX	UNIT : INCH [mm] SCALE : N/A REV. : C SIZE : A4 PAGE : 2
DRAWN BY	DATE		FILE NAME		
TAN QIGUANG	06-07-11		L886-1G2T-CN_C.DWG		

DC002(2)051509

This document is electronically generated. This is a controlled copy if used internally

bel
COMPONENTS FOR A
CONNECTED
PLANET

THE INFORMATION CONTAINED HEREIN IS CONSIDERED "PROPRIETARY" TO BEL FUSE INC. AND SHALL NOT BE COPIED, REPRODUCED OR DISCLOSED WITHOUT THE WRITTEN APPROVAL OF BEL FUSE INC.

RoHS
2002/95/EC



MECHANICAL SPECIFICATION

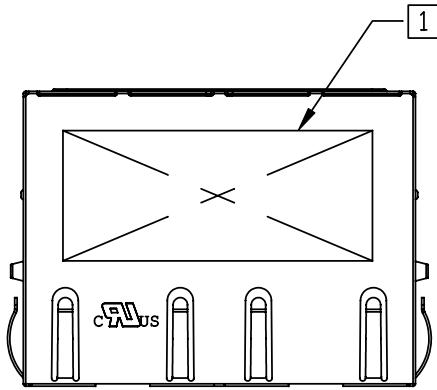

TOP VIEW

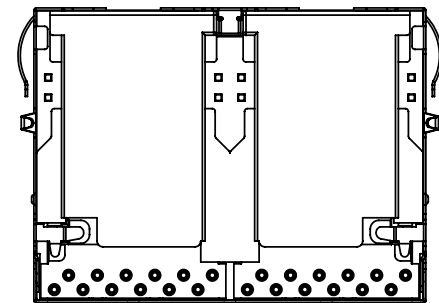
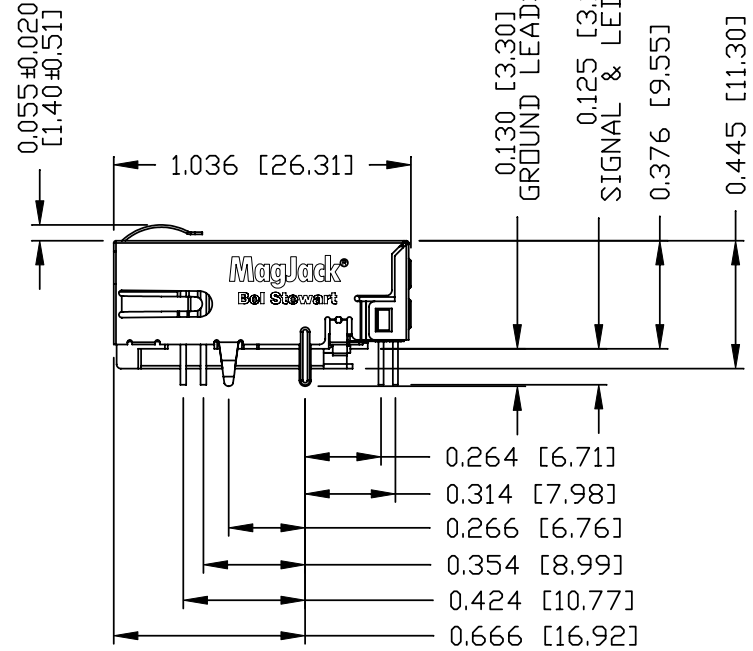
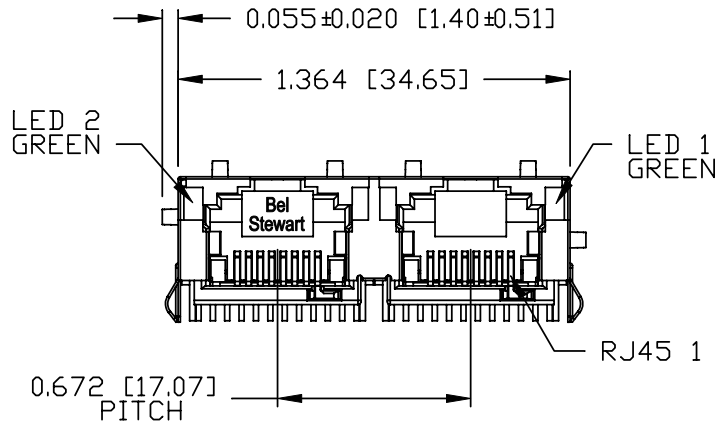

BOTTOM VIEW

NOTES:

- PLASTIC HOUSING: THERMOPLASTIC PA
FLAMMABILITY RATING UL 94V-0
- CONTACTS: 50 MICRO-INCH HARD GOLD PLATING
- OUTPUT PINS: TIN-COATED COPPER WIRE, DIA 0.018 INCH.
- METAL SHIELD: NICKEL PLATED ON COPPER ALLOY.
(ALL GROUND LEADS ARE SOLDER DIPPED)

1. MARK PART WITH PART NUMBER, DATE CODE AND PATENTED.

UL USUL RECOGNIZED - FILE #E196366 AND E169987.

- 2. RoHS COMPLIANCE, PER EU DIRECTIVE 2002/95/EC.
- 3. JACK CAVITY CONFORMS TO FCC RULES AND REGULATIONS.
- 4. THE PRODUCT IS PATENTED, THE PATENT NUMBER IS U.S. PAT. 5,736,910.

ORIGINATED BY	DATE	TITLE Gigabit MagJack® NanoJack (50 Micro-Inch Hard Gold Plating of -BF) PATENTED	PART NO. / DRAWING NO. L886-1G2T-CN	STANDARD DIM. TOL. IN INCH		[] METRIC DIM. AS REFERENCE	
CHEN BILL	06-07-11			.X		UNIT : INCH [mm]	REV. : C
DRAWN BY	DATE		FILE NAME L886-1G2T-CN_C.DWG	.XX		SCALE : N/A	SIZE : A4
HE ZHEN	06-07-11			.XXX	±0.010		PAGE : 3



THE INFORMATION CONTAINED HEREIN IS CONSIDERED "PROPRIETARY" TO BEL FUSE INC. AND SHALL NOT BE COPIED, REPRODUCED OR DISCLOSED WITHOUT THE WRITTEN APPROVAL OF BEL FUSE INC.

RoHS
2002/95/EC



RECOMMENDED PCB FOOTPRINT
COMPONENT SIDE VIEW

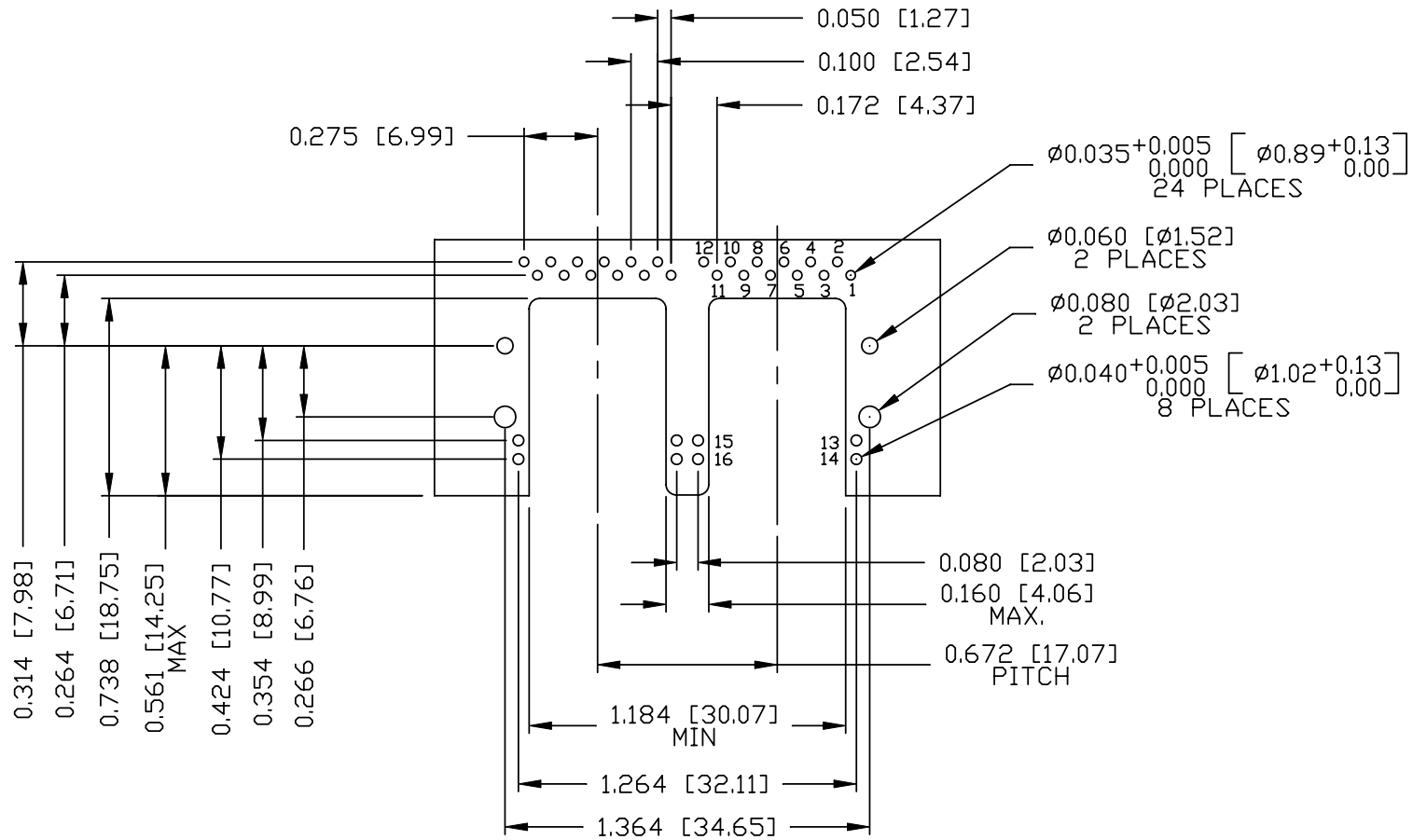

ORIGINATED BY	DATE	TITLE Gigabit MagJack® NanoJack (50 Micro-Inch Hard Gold Plating of -BF) PATENTED	PART NO. / DRAWING NO.	STANDARD DIM.	[] METRIC DIM. AS REFERENCE		 COMPONENTS FOR A CONNECTED PLANET
CHEN BILL	06-07-11		L886-1G2T-CN	TOL. IN INCH	UNIT : INCH [mm]	REV. : C	
DRAWN BY	DATE	FILE NAME	.X	SCALE : N/A	SIZE : A4		
HE ZHEN	06-07-11	L886-1G2T-CN_C.DWG	.XX	±0.004	PAGE : 4		

THE INFORMATION CONTAINED HEREIN IS CONSIDERED "PROPRIETARY" TO BEL FUSE INC. AND SHALL NOT BE COPIED, REPRODUCED OR DISCLOSED WITHOUT THE WRITTEN APPROVAL OF BEL FUSE INC.

RoHS
2002/95/EC



RECOMMENDED PCB FOOTPRINT
COMPONENT SIDE VIEW

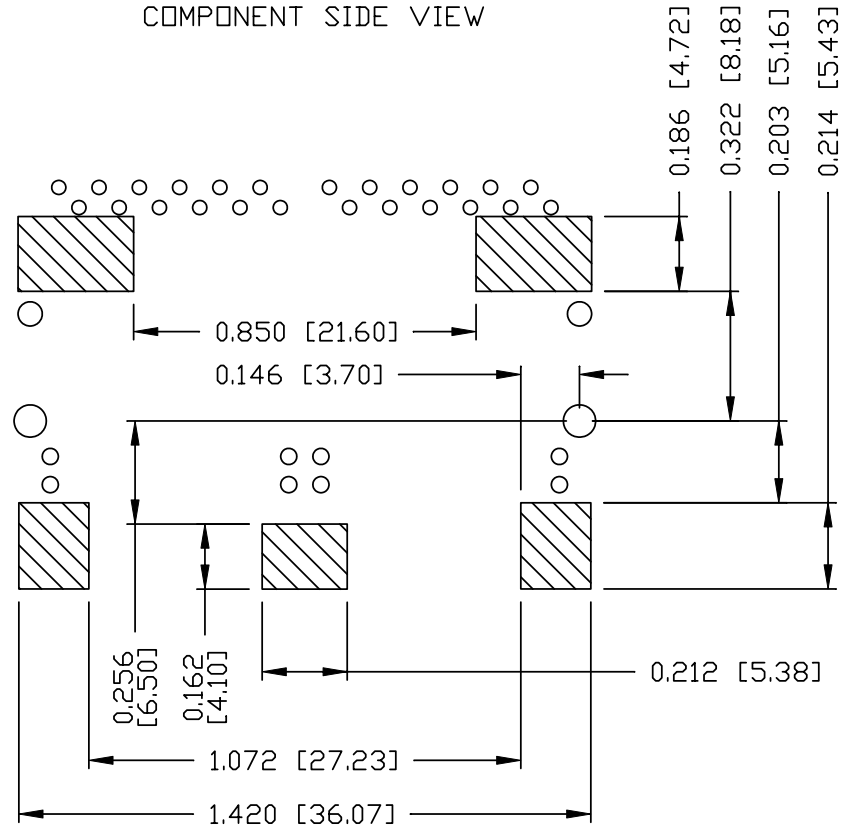

NOTES

THE SHADED AREA ON THE CUSTOMER BOARD ARE RECOMMENDED TO BE CLEAR OFF ANY VIA HOLE OR COMPONENT PAD.

ORIGINATED BY CHEN BILL	DATE 06-07-11	TITLE gigabit MagJack® NanoJack (50 Micro-Inch Hard Gold Plating of -BF) PATENTED	PART NO. / DRAWING NO. L886-1G2T-CN	STANDARD DIM. TOL. IN INCH		[] METRIC DIM. AS REFERENCE		REV. : C	bel
				.X		UNIT : INCH [mm]	SCALE : N/A		
DRAWN BY HE ZHEN	DATE 06-07-11		FILE NAME L886-1G2T-CN_C.DWG	.XX					COMPONENTS FOR A CONNECTED PLANET
				.XXX	±0.004			PAGE : 5	

THE INFORMATION CONTAINED HEREIN IS CONSIDERED "PROPRIETARY" TO BEL FUSE INC. AND SHALL NOT BE COPIED, REPRODUCED OR DISCLOSED WITHOUT THE WRITTEN APPROVAL OF BEL FUSE INC.

RoHS
2002/95/EC



SUGGESTED PANEL OPENING

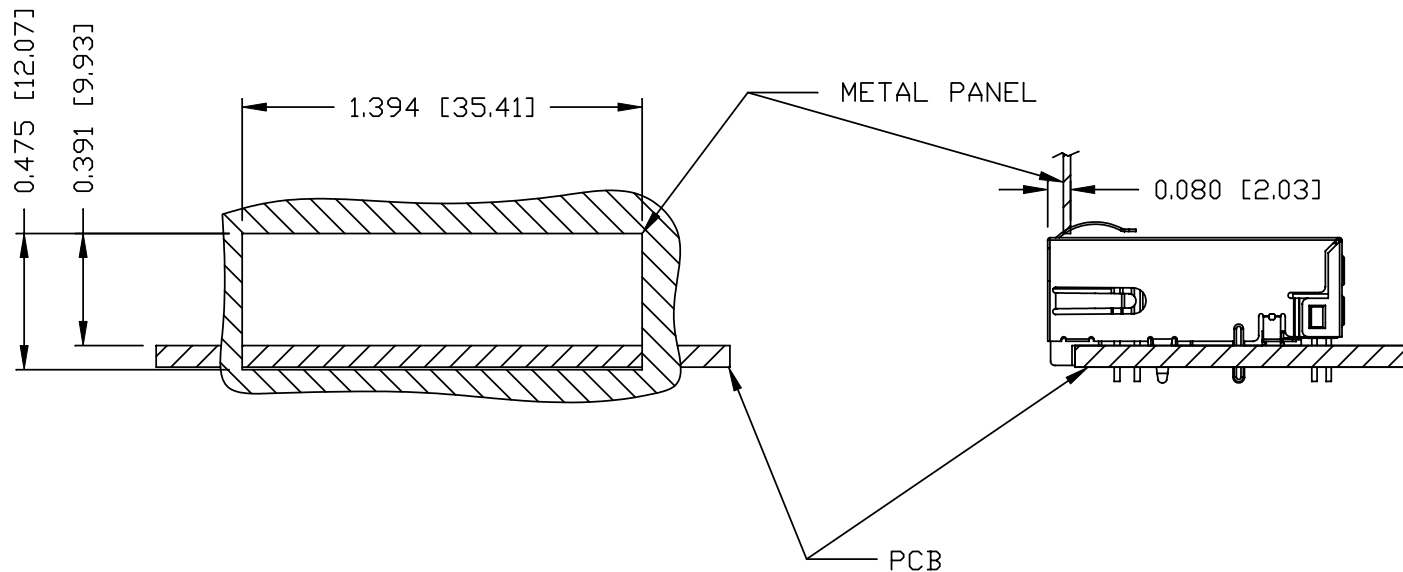

NOTES:

THE DISTANCE OF PANEL INSIDE SURFACE RELATIVE TO FRONT SURFACE OF PART IS ONLY A SUGGESTION. IN CASE THIS DISTANCE IS DIFFERENT, THE REQUIRED PANEL OPENING DIMENSIONS CHANGE ACCORDINGLY.

PACKING INFORMATION

PACKING TRAY : 0200M9999-C2 (TOP)

0200M9999-C3 (BOTTOM)

PACKING QUANTITY : 36 PCS FINISHED GOODS PER TRAY

12 TRAYS (432 PCS FINISHED GOODS) PER CARTON BOX

NOTER: CARDBOARDS ARE PLACED BETWEEN LAYERS OF PACKING TRAY INSIDE CARTON BOX (INCLUDE THE UPPERMOST AND LOWERMOST TRAY)

ORIGINATED BY	DATE	TITLE	PART NO. / DRAWING NO.	STANDARD DIM. TOL. IN INCH	[] METRIC DIM. AS REFERENCE	
CHEN BILL	06-07-11	Gigabit MagJack® NanoJack (50 Micro-Inch Hard Gold Plating of -BF) PATENTED	L886-1G2T-CN	.X	UNIT : INCH [mm] REV. : C	
DRAWN BY	DATE			FILE NAME	.XX	SCALE : N/A SIZE : A4
HE ZHEN	06-07-11			L886-1G2T-CN_C.DWG	.XXX	±0.004

