

FEATURES

- Trimmed 0.5% Tolerance
- Wide Operating Current Range 0.1μA to 10mA
- Low Reference Input Current 1.5nA
- Low Dynamic Output Impedance
- Low Output Noise
- Nominal Temperature Range to 125°C
- Temperature-Compensated: 50ppm/°C
- Low supply current: typ. 10μA

APPLICATIONS

- Battery Powered Systems
- Switching Power Supplies
- Isolated Power Supplies
- Telecommunications
- Error Amplifiers
- Notebook/Personal Computer
- Monitors/ VCR/ TV
- Opto-isolator driver

GENERAL DESCRIPTION

The AMS421 is a four-terminal adjustable open collector shunt regulator with guaranteed temperature stability over the entire range of operation. The output voltage can be set to any value between 0.5V (V_{REF}) and 15V by adding two external resistors. The AMS421 features 0.5% initial tolerance, low dynamic output impedance and operates over a wide current range. Due to the sharp turn-on characteristics this device is an excellent replacement for Zener diodes in many applications.

AMS421 is available 5 pin SOT-23 packages.

ORDERING INFORMATION:

TOL.	Package	OPERATING TEMP. RANGE
	5 LEAD SOT-23	
±0.5%	AMS421AM1	-40 to + 125°C
±1.0%	AMS421BM1	-40 to + 125°C
±2.0%	AMS421CM1	-40 to + 125°C

PIN CONNECTIONS

5L SOT-23 (M1)

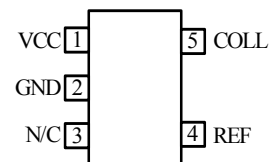

Top View

BLOCK DIAGRAM

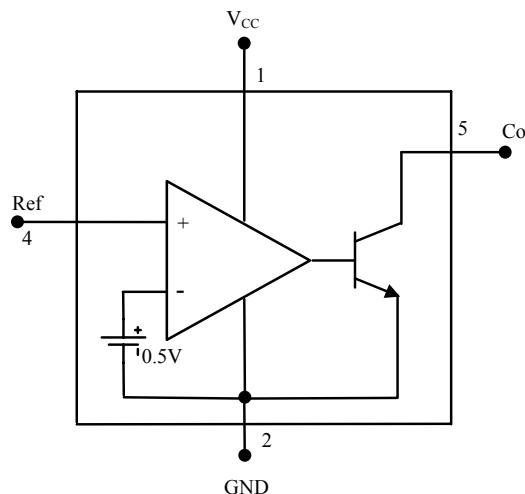

ABSOLUTE MAXIMUM RATINGS (Note 1)

Supply Voltage (V_{CC})	15V	Internal Power Dissipation (P_D)	
Continuous Collector Current (I_C)	10mA	SOT-23-5 Package	0.3 W
Reference Input Current (I_{REF})	0.5mA		
Junction Temperature (T_J)	-40°C to +125°C	Thermal Resistance (θ_{JA})	
Storage temperature	-65°C to +150°C	SOT-23-5 Package	410°C/W
Lead Temperature (Soldering, 10sec.)	265°C		

Note 1 : Absolute Maximum Ratings indicate limits beyond which damage to the device may occur. Operating Ratings indicate conditions for which the device is intended to be functional, but do not guarantee specific performance limits. For guaranteed specifications and test conditions, see the Electrical Characteristics. The guaranteed specifications apply only for the test conditions listed.

ELECTRICAL CHARACTERISTICS

Electrical Characteristics at $I_{COL}=1$ mA and $T_A = +25^\circ\text{C}$ unless otherwise noted.

Parameter	Conditions	AMS421A			AMS421B			AMS421C			Units
		Min	Typ	Max	Min	Typ	Max	Min	Typ	Max	
Reference Voltage		497.5	500.0	502.25	495.0	500.0	505.0	490.0	500.0	510.0	mV
Deviation of Reference Voltage over Temperature	$V_{COL} = V_{REF}$ $T_A = -40^\circ\text{C}$ to $+125^\circ\text{C}$		0.5	2.5		0.5	3		0.5	5	mV
Change in Reference Voltage to Supply Voltage	$I_{COL} = 100\mu\text{A}$ $V_{CC}=1.4\text{V}$ to 15V		0.5	1.0		0.5	1.5		0.5	2	mV
Reference Input Current	$I_{COL} = 0.1\mu\text{A}$ to 10mA		0.5	5		0.5	5		0.5	5	nA
Reference Input Current Deviation over Temperature	$I_{COL} = 0.1\mu\text{A}$ to 10mA $T_A = \text{Full Range}$		0.1	0.7		0.1	0.7		0.1	0.7	nA
Off State Collector Current	$V_{REF} = 0\text{V}$		0.04	0.1		0.04	0.1		0.04	0.1	nA
Dynamic Output Impedance	$f < 1\text{KHz}$, $I_{COL} = 1\text{ nA}$ to 10mA		0.35	0.5		0.35	0.5		0.35	0.5	Ω
Minimum Operating Current	$V_{COL} = V_{REF}$			0.1			0.1			0.1	nA
Input Supply Current	$I_{COL} = 100\mu\text{A}$		15	20		15	20		15	20	μA

RECOMMENDED OPERATING CONDITIONS:

	Min	Max
Collector Voltage, (V_{COL})	V_{REF}	15 V
Collector Current, (I_{COL})	1 μA	10mA

TYPICAL APPLICATIONS

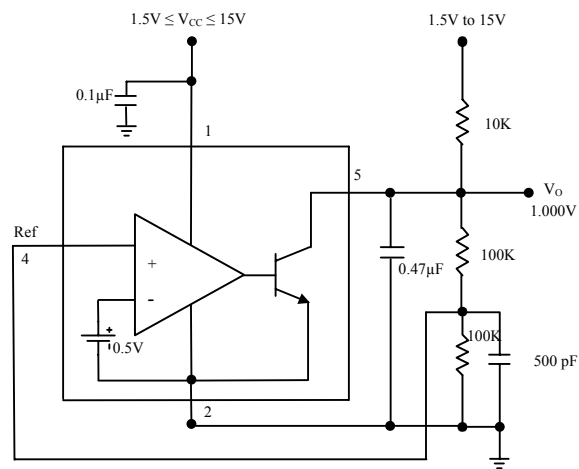

LOW NOISE PRECISSION 1.000V REFERENCE

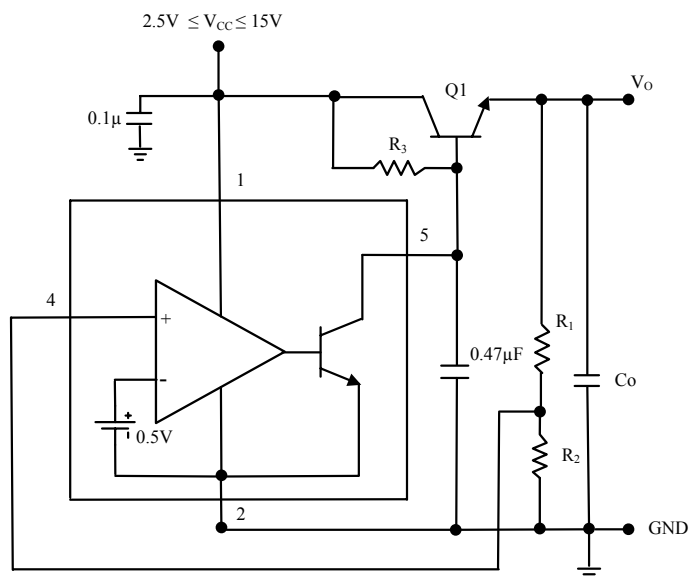

Low cost LDO using an External PNP
Set the V_{OUT} according to the following equation:

$$V_{OUT} = V_{REF} \left(1 + \frac{R_1}{R_2} \right) + I_{REF} R_1$$

Maximum output current is (PNP Hfe)10mA. The transistor current rating and package depends of the application dropout. The power dissipation for the PNP transistor is $I_{out} (V_{in} - V_{out})$. The package type should be selected according to the Power dissipation.

TYPICAL PERFORMANCE CHARACTERISTICS

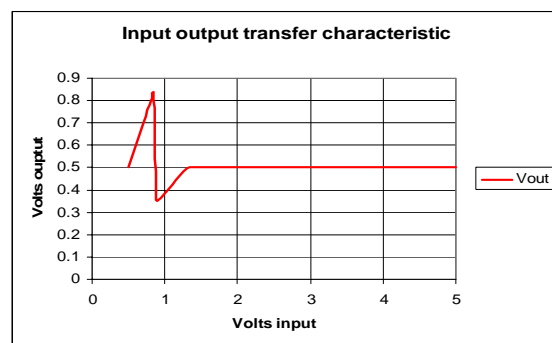
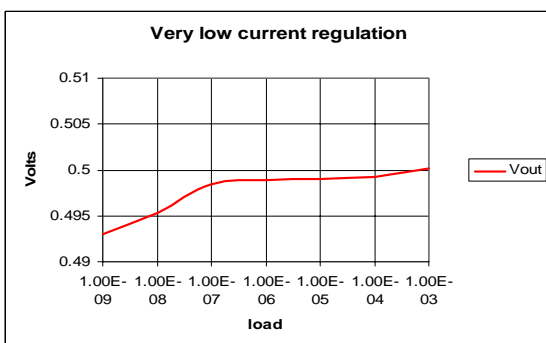
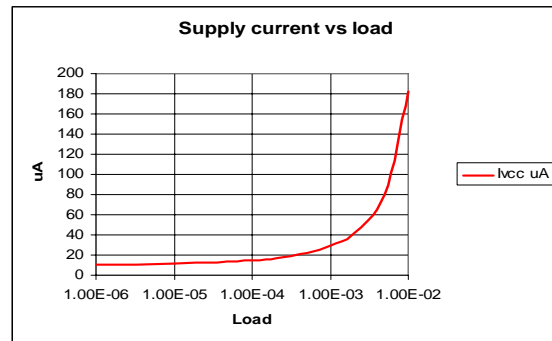
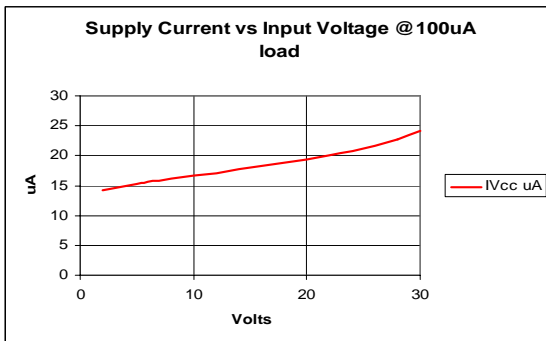
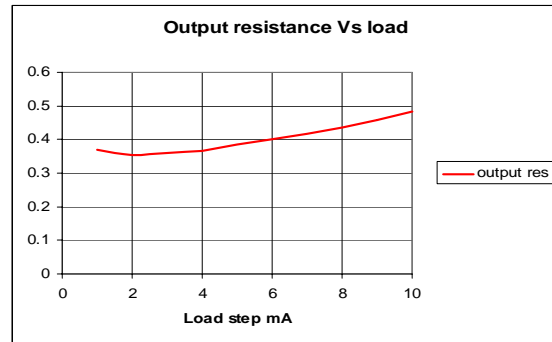
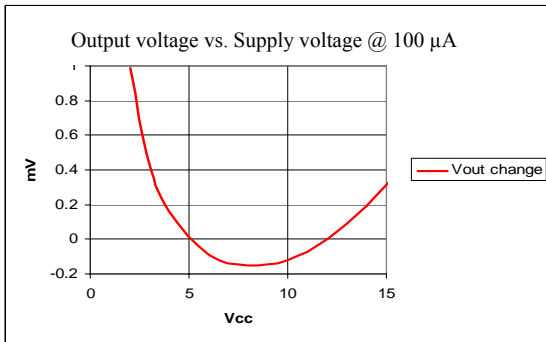

TYPICAL PERFORMANCE CHARACTERISTICS (Continued)

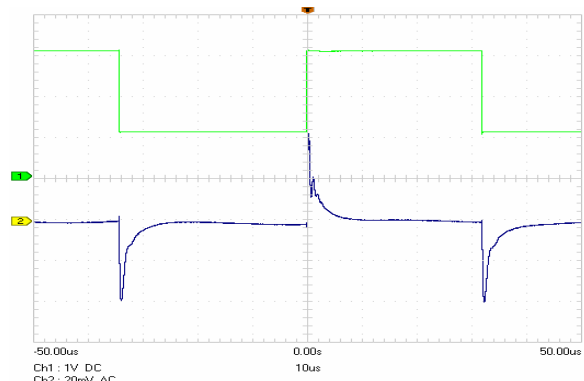
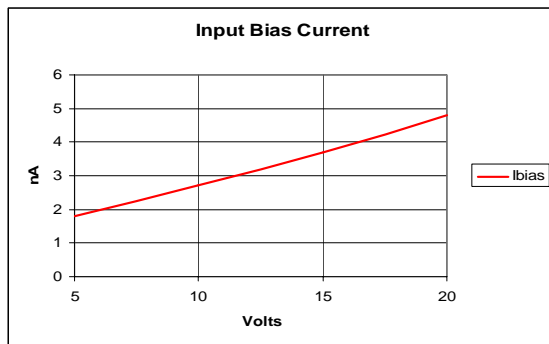
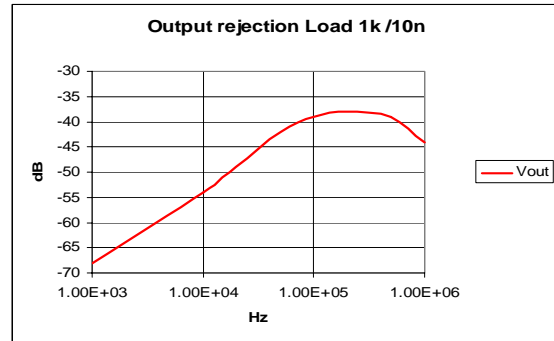
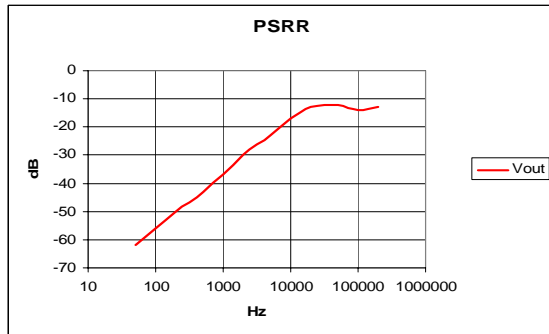

2 mA load Transient @ VCC=5V, Output Cap=10 nF

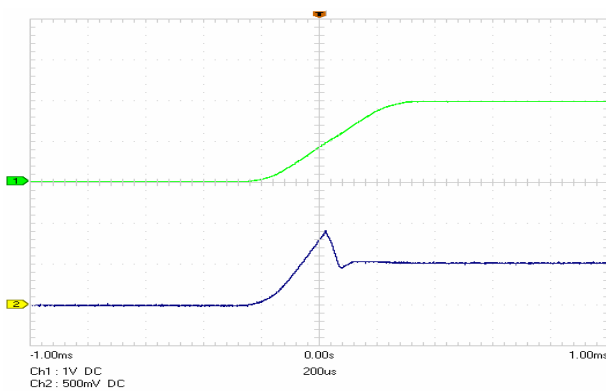

2 mA load Transient at VCC=15V, Output Cap=10nF

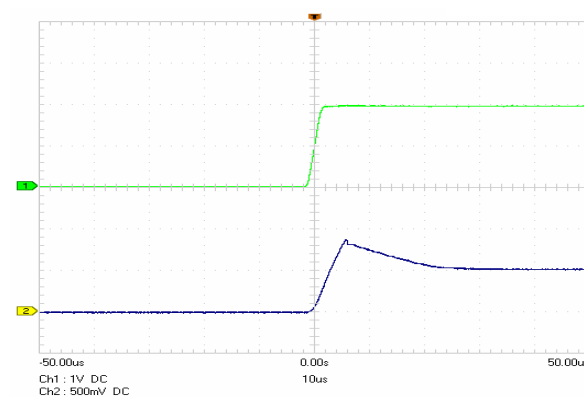

Fast Start up 0-2V with common supply

TYPICAL PERFORMANCE CHARACTERISTICS (Continued)

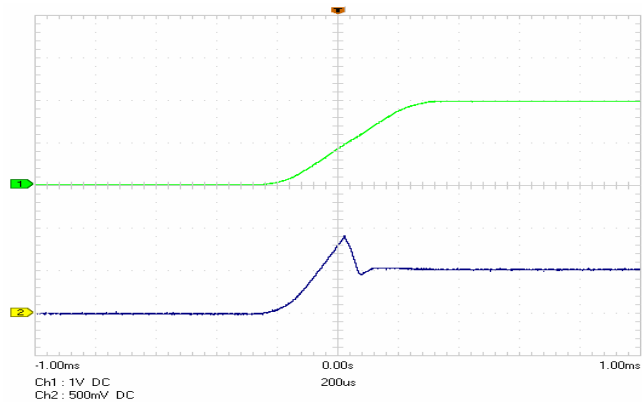

Slow Start up 0-2V with common supply

PACKAGE DIMENSIONS inches (millimeters) unless otherwise noted.

5 LEAD SOT-23 PLASTIC PACKAGE (M1)

