

## Micropower 500mA Low Noise Fast Transient Response LDO

### General Description

The AMS3106 is a high performance linear regulator with very low dropout voltage and excellent transient response. It is designed to operate with wide input voltage range of 1.5 – 12Volts making it ideal for two step conversion while maintaining high efficiency for many power sensitive applications. The device is capable of supplying 500mA of output current with a typical dropout voltage of 425mV. The product is available in either fixed or adjustable output voltage.

The linear regulator has been optimized for noise sensitive applications. The device includes an Enable pin for electrical on/off of the regulator. Forcing the Enable pin to logic low shuts down the LDO and reduces the supply current below 1 $\mu$ A. In addition, the AMS3106 provides an optional open collector Power Good (PG) signal to allow supply monitoring and sequencing of other supplies.

The product includes complete short-circuit and thermal protection. The combination of these two internal protection circuits gives the device a comprehensive safety system to safe guard against extreme adverse operating conditions.

The AMS3106 is available in SOT23-5 and thermally enhanced SOIC-8 EDP packages, and it is rated for -40°C to +125°C temperature range.

### Features

- $V_{IN}$  range: 1.5 – 12V
- Fixed and Adjustable output voltage as low as 0.6V
- 500mA maximum output current
- 425mV of typical dropout voltage
- Low self noise
- Enable (EN) pin for LDO on/off
- Optional Power Good (PG) output
- 120 $\mu$ A typical supply current
- Optional ByPass ( $C_{BYP}$ ) pin for low PSRR and output noise
- PSRR > 40dB at 10KHz
- Stable with Electrolytic, Tantalum or Ceramic capacitors
- Current Limit protection
- Over-Temperature Shutdown
- -40 to +125°C temperature range
- Available in SOIC-8 EDP and SOT23-5 packages
- RoHS & WEEE compliant

### Applications

- ASIC Power Supplies In:
  - Set-top Boxes, Desktops, Notebooks
  - Graphic Cards, Printers and Copiers
- DVD, Blue-Ray DVD writers
- LCD TVs and LCD monitors
- Infotainment
- Wireless & RF: applications
- DSP and FPGA Power Supplies
- Medical Instrumentation
- SMPS Post-Regulator

### Typical Application

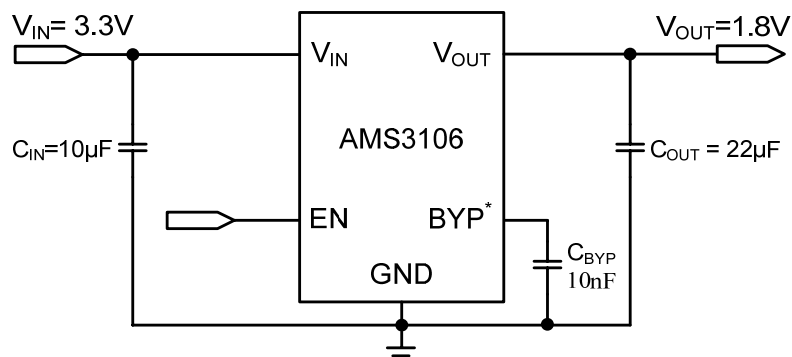

\*Optional Power Good and adjustable  $V_{OUT}$  are available

## Micropower 500mA Low Noise Fast Transient Response LDO

### Pin Description (SOIC-8 EDP package)

Pin #	Symbol	Description
1	EN	Enable pin. It controls the electrical on/off of the device. When connected to logic low, the device shuts off and consumes less than 1µA of current. Logic high will resume normal operation.
2	V <sub>IN</sub>	Input supply Voltage. It powers the internal control circuitry and the internal power switch. Bypass V <sub>IN</sub> with at ceramic capacitor from this pin to ground.
3	V <sub>OUT</sub>	Output Voltage
4	BYP	Reference Bypass pin. Connect an external capacitor from C <sub>BYP</sub> to ground to bypass the noise generated by the internal bandgap. This improves power supply rejection ratio and output noise.
	PG	Power Good pin. It is an open collector, active high output that indicates the status of the output voltage. When output voltage (V <sub>OUT</sub> ) exceeds the PG trip threshold, the PG pin goes in to a high impedance state. When the device is out of regulation or shutdown, the PG pin is pulled low. A 10KΩ to 1MΩ resistor should be connected from PG to V <sub>OUT</sub> .
	ADJ	Provides feedback to error amplifier from the resistive divider that sets the output voltage.
5,6,7,8	GND	Ground connection.
9	EDP	Expose pad. Connected to PCB ground plane for good thermal dissipation.

### Pin Configuration

#### SOIC-8 EDP (Top View)

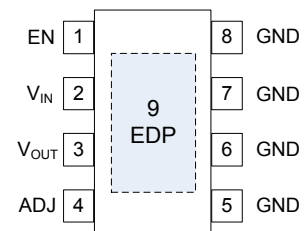
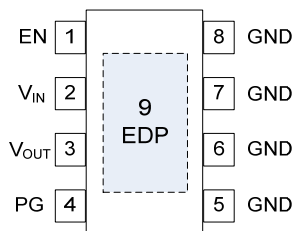
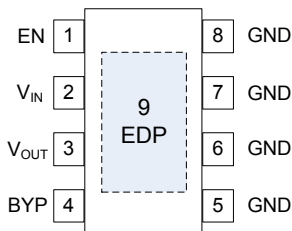

## Micropower 500mA Low Noise Fast Transient Response LDO

### Pin Description (SOT23-5 package)

Pin #	Symbol	Description
1	$V_{IN}$	Input supply Voltage. It powers the internal control circuitry and the internal power switch. Bypass $V_{IN}$ with at ceramic capacitor from this pin to ground.
2	GND	Ground connection.
3	EN	Enable pin. It controls the electrical on/off of the device. When connected to logic low, the device shuts off and consumes less than 1 $\mu$ A of current. Logic high will resume normal operation.
4	BYP	Reference Bypass pin. Connect an external capacitor from $C_{BYP}$ to ground to bypass the noise generated by the internal bandgap. This improves power supply rejection ratio and output noise.
	PG	Power Good pin. It is an open collector, active high output that indicates the status of the output voltage. When output voltage ( $V_{OUT}$ ) exceeds the PG trip threshold, the PG pin goes in to a high impedance state. When the device is out of regulation or shutdown, the PG pin is pulled low. A 10K $\Omega$ to 1M $\Omega$ resistor should be connected from PG to $V_{OUT}$ .
	ADJ	Provides feedback to error amplifier from the resistive divider that sets the output voltage.
5	$V_{OUT}$	Output Voltage

### Pin Configuration

#### SOT23-5 (Top View)

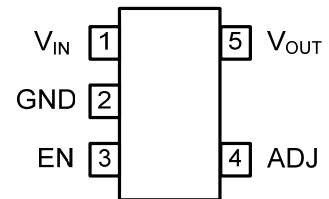
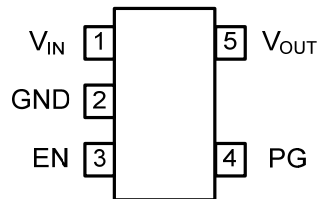
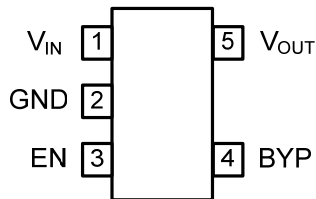

## Micropower 500mA Low Noise Fast Transient Response LDO

### Absolute Maximum Ratings <sup>(1)</sup>

Maximum Input Supply Voltage (V <sub>IN</sub> )	-0.3V to 15V
Enable Voltage (EN)	-0.3V to 15V
Power Good (PG)	-0.3V to 15V
Adjustable Voltage (ADJ)	-0.3V to 3V
ByPass Voltage (BYP)	-0.3V to 3V
Storage Temperature Range	-65°C to 150°C
Lead Temperature	260°C
Junction Temperature	125°C

### Recommended Operating Conditions <sup>(2)</sup>

Input Voltage	1.5V to 12V
Ambient Operating Temperature	-40°C to 125°C

### Thermal Information

8L SOIC EP $\theta_{JA}$ <sup>(3)</sup>	45°C/W
5L SOT23... $\theta_{JA}$ <sup>(3)</sup>	220°C/W

### Electrical Characteristics

Unless otherwise noted: V<sub>IN</sub>=3.3V, V<sub>OUT</sub>=1.8V; C<sub>IN</sub>=10 μF, C<sub>OUT</sub>=22μF, -40°C≤T<sub>A</sub>=T<sub>J</sub>≤85°C, T<sub>J(Max.)</sub>=125°C; Typical values are T<sub>A</sub>=25°C

Parameter	Symbol	Conditions	Min.	Typ.	Max.	Units
Output Voltage Accuracy AMS3106A-X	V <sub>OUT</sub>	(Adjustable)	-1		1	%
		(Fixed Output) 1mA≤I <sub>O</sub> ≤500mA	-2		2	%
Output Voltage Accuracy AMS3106-X	V <sub>OUT</sub>	(Adjustable)	-2		2	%
		(Fixed Output) 1mA≤I <sub>O</sub> ≤500mA	-3.5		3.5	%
Adjustable Voltage	V <sub>ADJ</sub>	Adjustable V <sub>OUT</sub> only AMS3106A-X	0.594	0.600	0.606	V
Adjustable Voltage	V <sub>ADJ</sub>	Adjustable V <sub>OUT</sub> only AMS3106-X	0.588	0.600	0.612	
Adjustable bias current	I <sub>ADJ_Bias</sub>	Adjustable V <sub>OUT</sub> only		10	100	nA
Maximum Output Current	I <sub>OUT_Max</sub>		500			mA
Load Regulation		I <sub>OUT</sub> = 0 – 500mA		0.5		%
Line Regulation		V <sub>IN</sub> =3.0 – 12V; I <sub>OUT</sub> =100mA		0.15		%
Supply Current	I <sub>SUP</sub>	V <sub>IN</sub> =3.3V, I <sub>O</sub> =0A		120	150	μA
Shutdown Current	I <sub>SHDN</sub>	V <sub>IN</sub> =3.3V, V <sub>EN</sub> =0V		<1		μA
Current Limit	I <sub>LIM</sub>			650		mA
Dropout Voltage	V <sub>DO</sub>	I <sub>OUT</sub> =100mA; V <sub>OUT</sub> =95% of V <sub>OUT(NOM)</sub>		220		mV
		I <sub>OUT</sub> =250mA; V <sub>OUT</sub> =95% of V <sub>OUT(NOM)</sub>		300		
		I <sub>OUT</sub> =500mA; V <sub>OUT</sub> =95% of V <sub>OUT(NOM)</sub>		425		
PSRR	ΔV <sub>OUT</sub> /ΔV <sub>IN</sub>	F=10KHz I <sub>O</sub> =20mA		33		dB
Output Noise Voltage	e <sub>n</sub>	Opt. C <sub>BYP</sub> Pin Only BW: 100Hz–100 KHz C <sub>OUT</sub> = 22μF I <sub>LOAD</sub> = 150mA	No C <sub>BYP</sub>		118	μV(rms)
			C <sub>BYP</sub> = 10nF		33	
Enable Threshold Low	V <sub>EN(L)</sub>			1		V
Enable Threshold High	V <sub>EN(H)</sub>			1.1		V
Input Enable Low Current	I <sub>EN(L)</sub>	V <sub>EN</sub> = 0V		0	10	nA
Input Enable High Current	I <sub>EN(H)</sub>	V <sub>EN</sub> = 1.5V		150	300	nA
Power Good Low Threshold	V <sub>PG</sub>	% of V <sub>OUT</sub> PG ON / Opt. PG Pin only	89			%
Power Good High Threshold	V <sub>PG</sub>	% of V <sub>OUT</sub> PG OFF / Opt. PG Pin only			97	%
Power Good Output Low Voltage	V <sub>PGL</sub>	IPG_SINK = 500μA, Fault Condition		200	300	mV
Power Good Leakage Current	I <sub>PG</sub>	PG off, V <sub>PG</sub> = 12V		0.01		μA
Thermal Shutdown	T <sub>SD</sub>			145		°C
Thermal Shutdown Hysteresis	T <sub>SD_HYS</sub>			15		°C

#### Notes:

- Stresses above those listed in Absolute Maximum Ratings may cause permanent damage to the device.
- Measured on approximately 1" square of 1 oz. copper.
- The total power dissipation for SO-8 EDP package is recommended to 2.5W rated at 25°C ambient temperature. The thermal resistance Junction to Case is 45°C/W. Total power dissipation for the switching regulator and the LDO should be taken in consideration when calculating the output current capability of each regulator.

## Micropower 500mA Low Noise Fast Transient Response LDO

Typical Performance Characteristics ( $T_A = 25^\circ\text{C}$  unless otherwise specified)

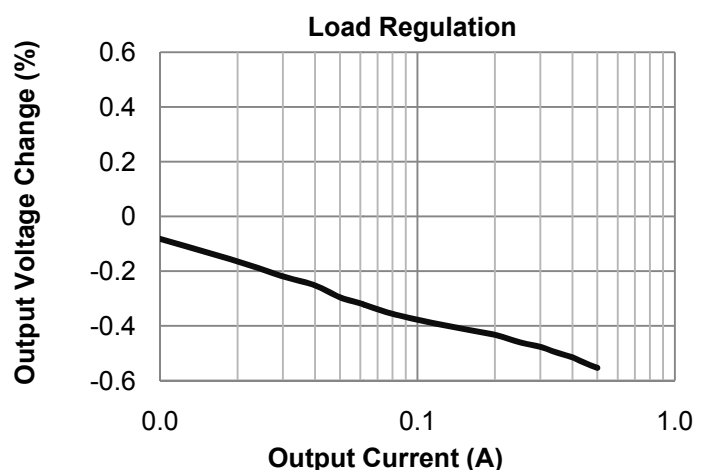
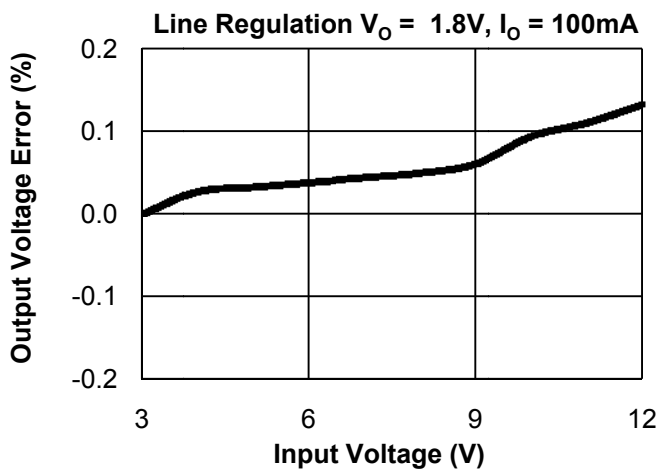
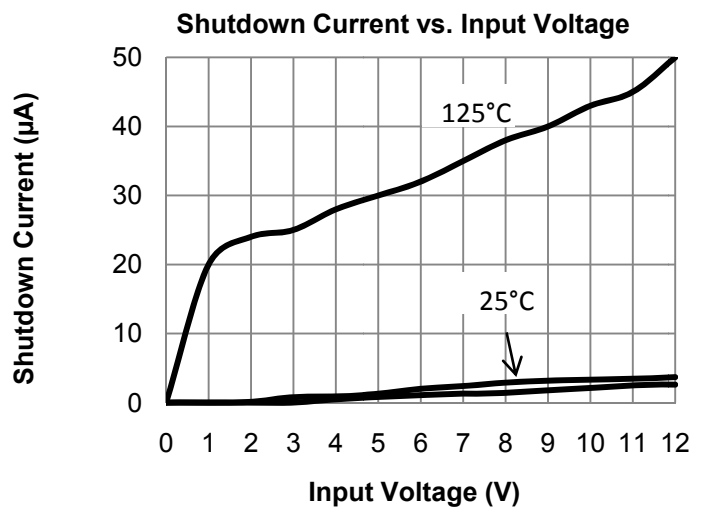
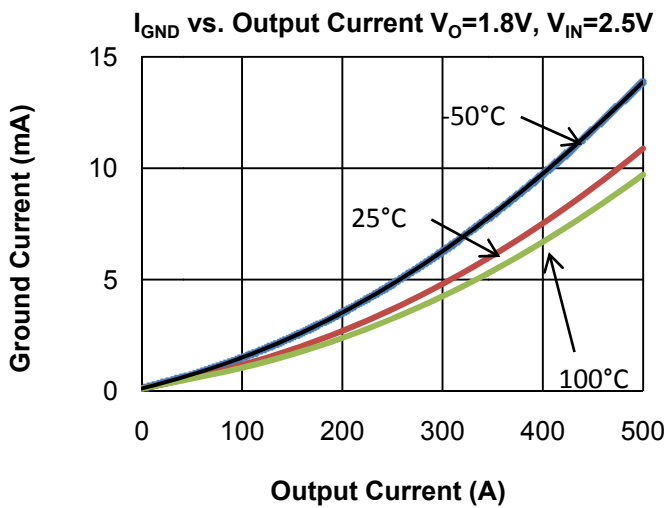
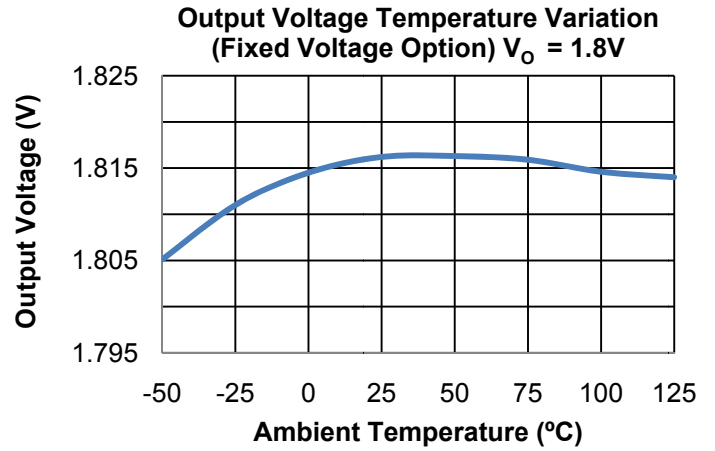
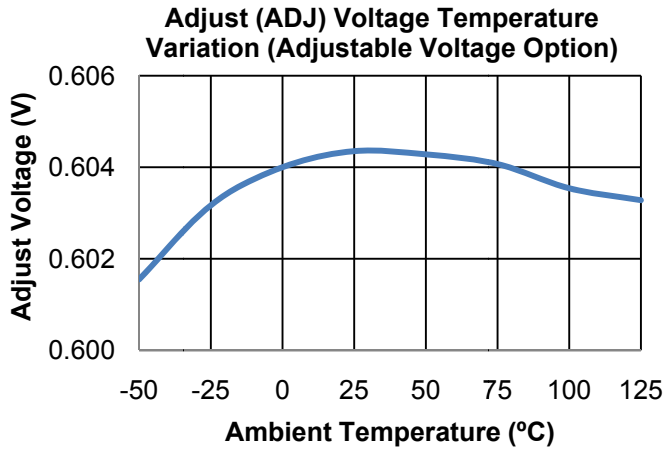

## Micropower 500mA Low Noise Fast Transient Response LDO

Typical Performance Characteristics ( $T_A = 25^\circ\text{C}$  unless otherwise specified)

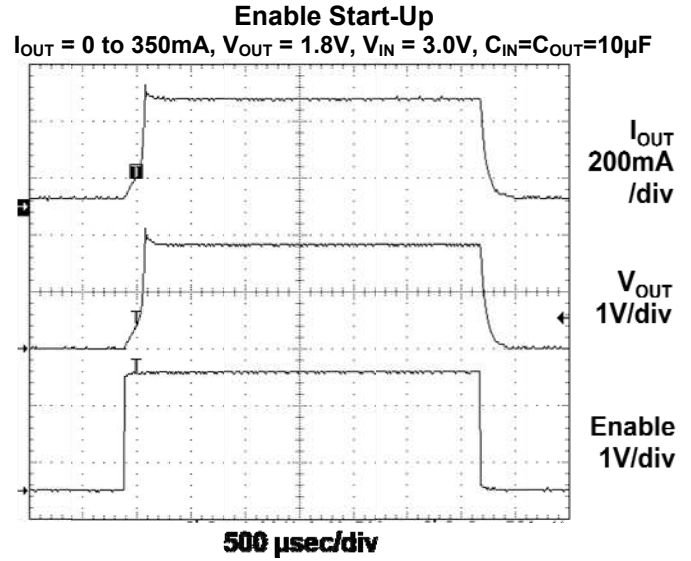
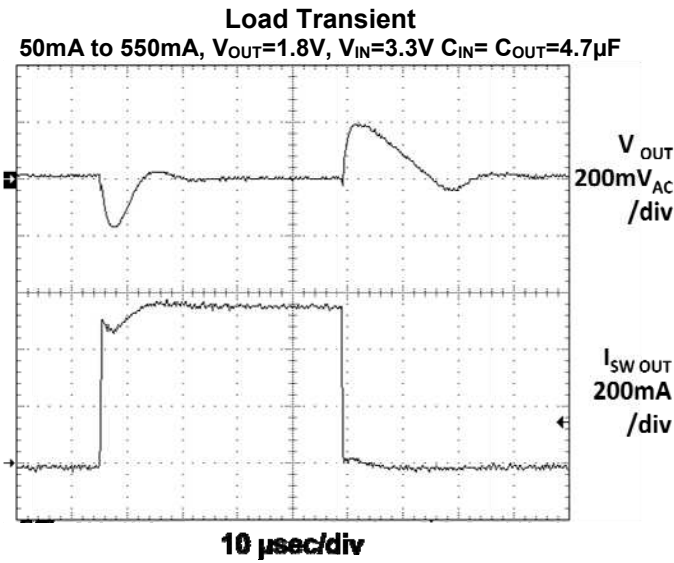
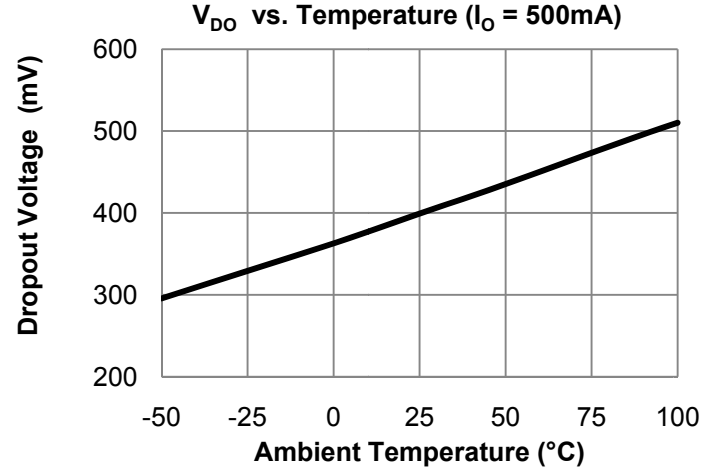
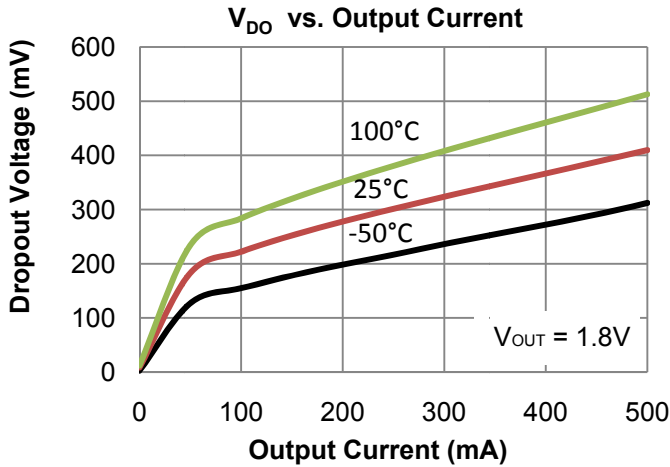

## Micropower 500mA Low Noise Fast Transient Response LDO

### Functional Block Diagram

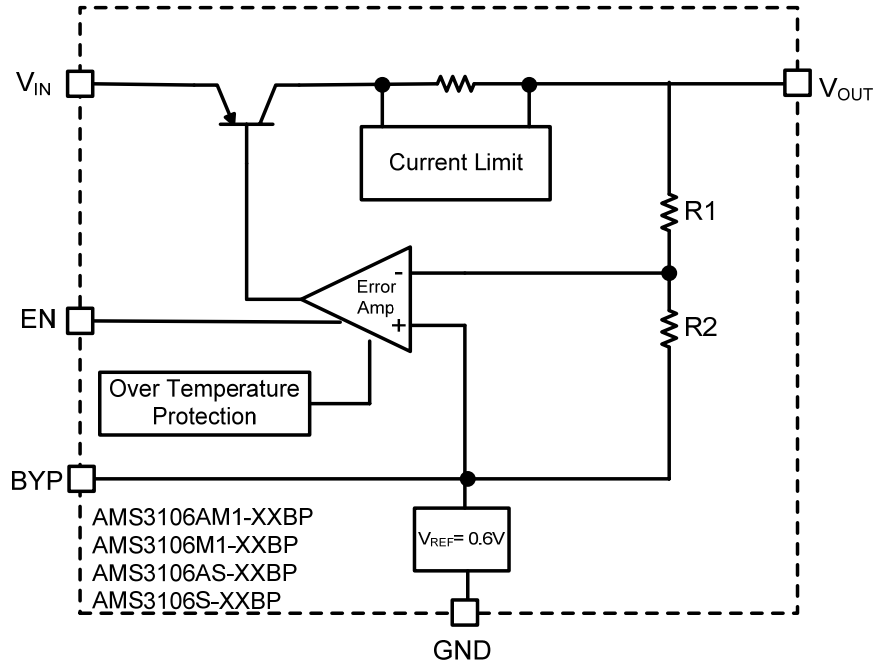

**Figure 1: Block Diagram of AMS 3106 with ByPass Pin Option**

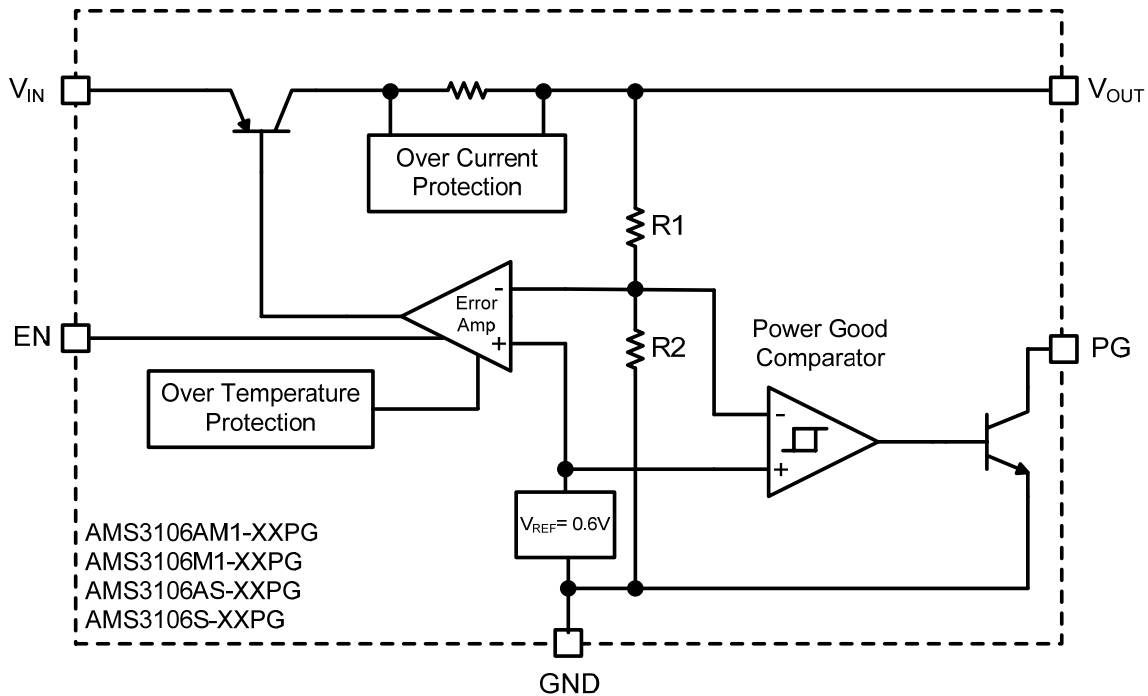

**Figure 2: Block Diagram of AMS 3106 with Power Good Pin Option**

## Micropower 500mA Low Noise Fast Transient Response LDO

### Functional Block Diagram

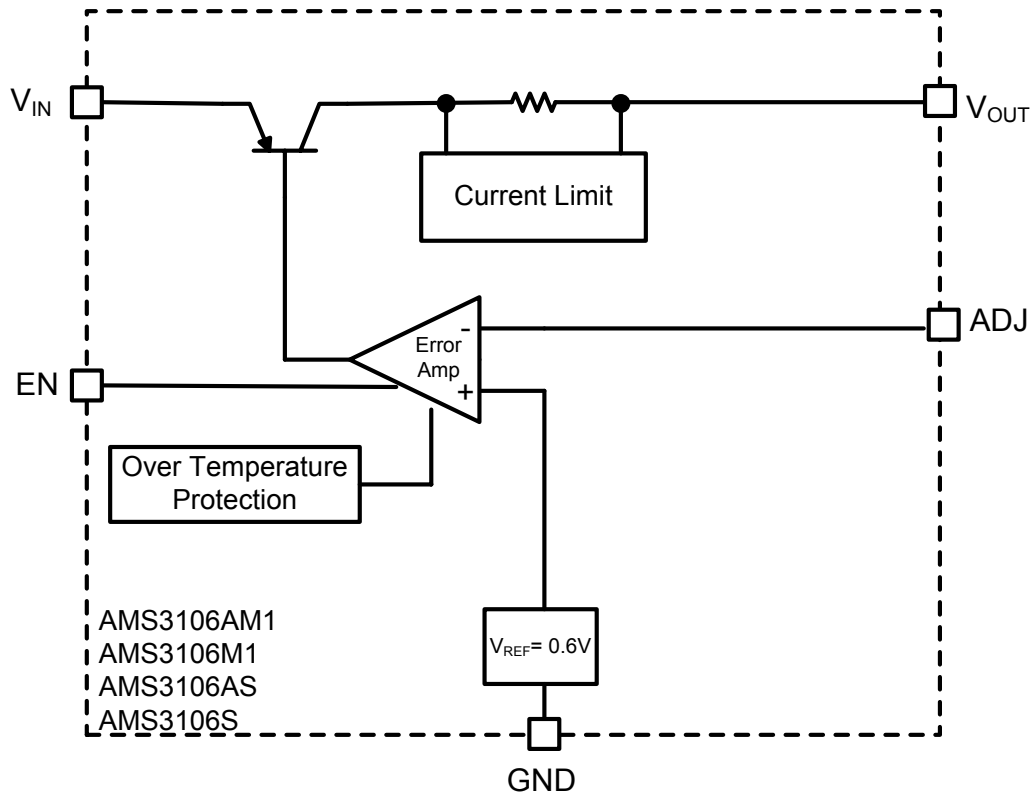

**Figure 3: Block Diagram of AMS 3106 with Adjustable Pin Option**



## Micropower 500mA Low Noise Fast Transient Response LDO

### Device Summary

The AMS3106 is a high voltage low drop out linear regulator with a current capability of up to 500mA. The LDO has an input voltage range of 1.5V to 12V with an output voltage as low as 0.6V and is stable with a wide range of ceramic, tantalum, and electrolytic output capacitors.

### Shutdown/Enable

The Enable (on/off) input threshold voltage is 1.1V. When disabled the LDO quiescent current decreases to a typical value of <math><1\mu\text{A}</math>.

### Fault Protection

Short circuit and over-temperature shutdown disable the converter and LDO in the event of an overload condition. Over-temp shutdown disables the device when the junction temperature exceeds 145 °C. The output current is internally limited to 650mA.

### Input Capacitor

An input bypass capacitor ranging from 1μF to 10μF is required. The capacitor should be placed as close as possible to the device and not be placed more than 1 inch from the LDO.

### Output Capacitor

The output capacitor requirements range from the minimum value required to guarantee stability to a larger value required to meet the extreme transient response requirements. Values range from 10 to 22μF X5R ceramic capacitors. Due to the extreme voltage coefficient of X5R ceramic capacitors, the voltage rating should be at least double the maximum applied voltage.

### Bypass Capacitor

If the ByPass (BYP) is available, connecting a capacitor between the BYP pin and ground can significantly reduce output noise. Values can range from 0pF to 10nF, depending on the sensitivity to output noise in the application. The start-up speed of the AMS3106 is inversely proportional to the size of the bypass capacitor. Applications requiring a slow ramp-up of output voltage should consider larger values of bypass capacitance. Likewise, if rapid turn-on is necessary, consider omitting  $C_{\text{BYP}}$ .

Because the ByPass (BYP) pin is high-impedance, careful considering must be taken in the PCB layout to minimize noise pickup, and capacitors must be selected to minimize current leakage. Current leakage into the BYP pin will directly affect the regulator's accuracy and should be kept low as possible. Using high quality ceramic and film type's capacitors are recommended for their low leakage characteristics.

### Adjustable Version: Feedback Resistor Selection

Choosing AMS 3106 with adjustable output voltage option allows the user to select an output voltage by using an external resistor divider. AMS 3106 uses a 0.6V reference voltage at the positive terminal of the error amplifier. To set the output voltage a programming resistor from the adjust pin (ADJ) to ground must be selected (See Pg.1). A 10kΩ resistor is a good selection for a programming resistor R2. A higher value may result in an excessively sensitive feedback node while a lower value will draw more current and degrade the light load efficiency. The equation for selecting the voltage specific resistor is:

$$R1 = \left(\frac{V_{\text{out}}}{V_{\text{ref}}} - 1\right) \cdot R2 = \left(\frac{1.8\text{V}}{0.6\text{V}} - 1\right) \cdot 10\text{k}\Omega = 20\text{k}\Omega$$

**Table 1: Adjustable Feedback Resistor values**

$V_{\text{OUT}}$ (V)	R1 (kΩ) (R2=10kΩ)
1.8	20.0
2.5	31.6
3.3	45.3
5.0	73.2

### Power Good

During operation, fault conditions can occur unexpectedly. Such conditions include input voltage dropout (low  $V_{\text{IN}}$ ), overheating, or overloading (excessive output current). If any of these conditions occurs, the PG pin will set an "error flag". The PG pin, which is an open-collector output, will go LOW when  $V_{\text{OUT}}$  is less than 95% or the specified output voltage. When the voltage at  $V_{\text{OUT}}$  is greater than 95% of the specified output voltage, the PG pin is HIGH. A logic pull-up resistor of 10KΩ is recommended at this output. The pin can be left disconnected if unused.

## Micropower 500mA Low Noise Fast Transient Response LDO

### PCB Layout

The following guidelines should be followed to insure proper layout.

1.  $V_{IN}$  Capacitor. A low ESR ceramic bypass capacitor must be placed as close to the IC as possible.
2. (ADJ) Feedback Resistors. The (ADJ) feedback resistors should be placed as close as possible to the IC. Minimize the length of the trace from the feedback pin to the resistors. This is a high impedance node susceptible to interference from external RF noise sources.
3. Ground.
4. For good thermal performance vias are required to couple the exposed tab of the SO-8 package to the PCB ground plane. The via diameter should be 0.3mm to 0.33mm positioned on a 1.2mm grid.

### Output Power and Thermal Limits

The AMS3106 junction temperature and current capability depends on the internal dissipation and the junction to case thermal resistance of the SO-8 exposed paddle package.

Additionally, the paddle and PCB temperature will be elevated due to the total losses of the LDO and of other circuits mounted to the PCB.

$$T_{jmax} = P_d \cdot \theta_{jc} + T_{pcb} + T_{amb}$$

The internal losses contribute to the junction temperature rise above the paddle and PCB temperature.

## Micropower 500mA Low Noise Fast Transient Response LDO

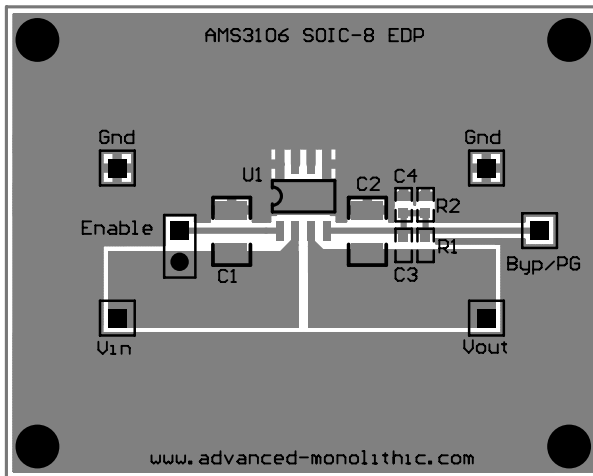

Figure 4: AMS3106 SOIC-8 Evaluation Board Top Side

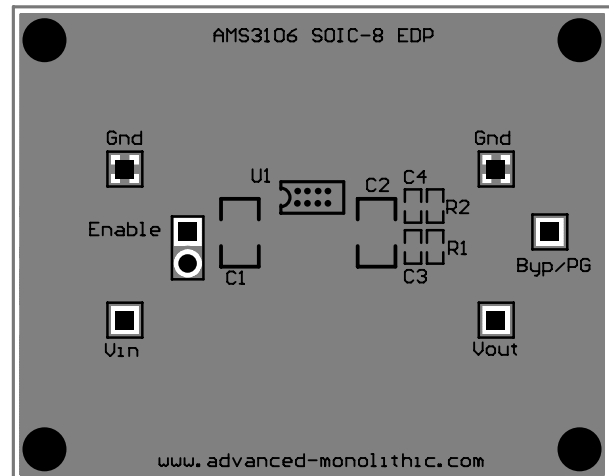

Figure 5: AMS3106 SOIC-8 Evaluation Board Bottom Side

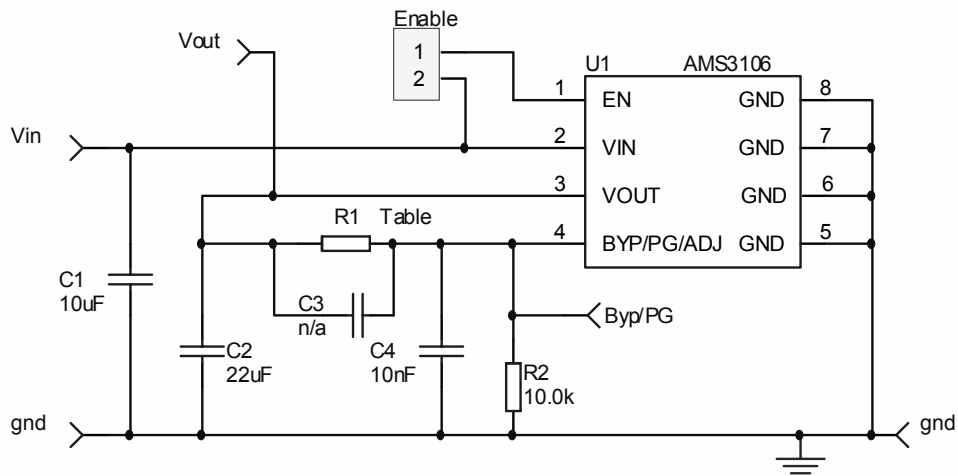

Figure 6: AMS3106 SOIC-8 Evaluation Board Schematic

Table 2: AMS3106 SOIC-8 Evaluation Board Bill of Materials

Component	Value	Manufacturer	Manufacturer Part Number	
C1	10 $\mu$ F, 50V, X5R, 1210, Ceramic	Taiyo Yuden	UMK325BJ106KM-T	
C2	22 $\mu$ F, 10V, X5R, 0805, Ceramic	Taiyo Yuden	LMK212BJ226MG-T	
C3	Optional Feedforward			
C4	10nF, 50V,20%,X7R,0603 Bypass Version Only.	Murata	GRM188R71H103MA01	
R1	1.2V	10.0k $\Omega$ , 0.1W, 0603 1%	Various	CRCW0603xxKxKFKEA
	1.8V	20.0k $\Omega$ , 0.1W, 0603 1%	Various	CRCW0603xxKxKFKEA
	2.5V	31.6k $\Omega$ , 0.1W, 0603 1%	Various	CRCW0603xxKxKFKEA
	3.3V	45.3k $\Omega$ , 0.1W, 0603 1%	Various	CRCW0603xxKxKFKEA
	5.0V	73.2k $\Omega$ , 0.1W, 0603 1%	Various	CRCW0603xxKxKFKEA
R1	PG	100k $\Omega$ , 0.1W, 0603 1% Power Good version Only.	Various	CRCW0603100KFKEA
R2		10.0k $\Omega$ , 0.1W, 0603 1%	Various	CRCW060310K0FKEA
U1		Linear Regulator	AMS	AMS3106 SOIC-8 EDP

## Micropower 500mA Low Noise Fast Transient Response LDO

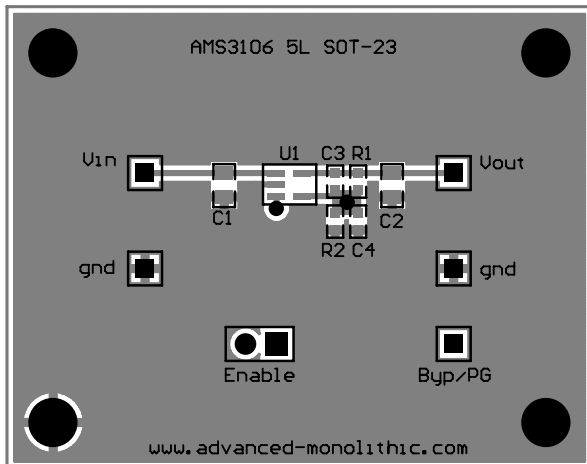

Figure 7: AMS3106 SOT23-5 Evaluation Board Top Side

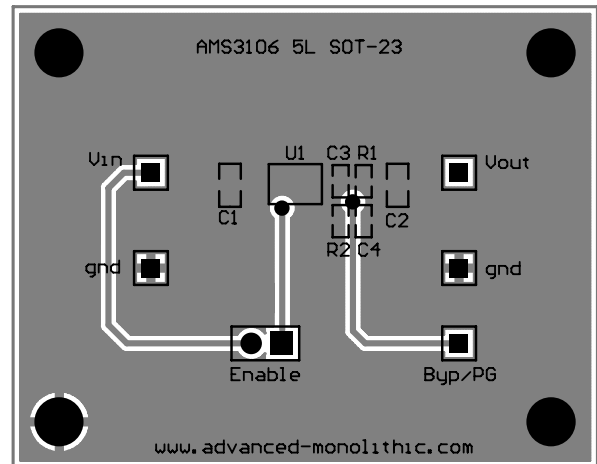

Figure 8: AMS3106 SOT23-5 Evaluation Board Bottom Side

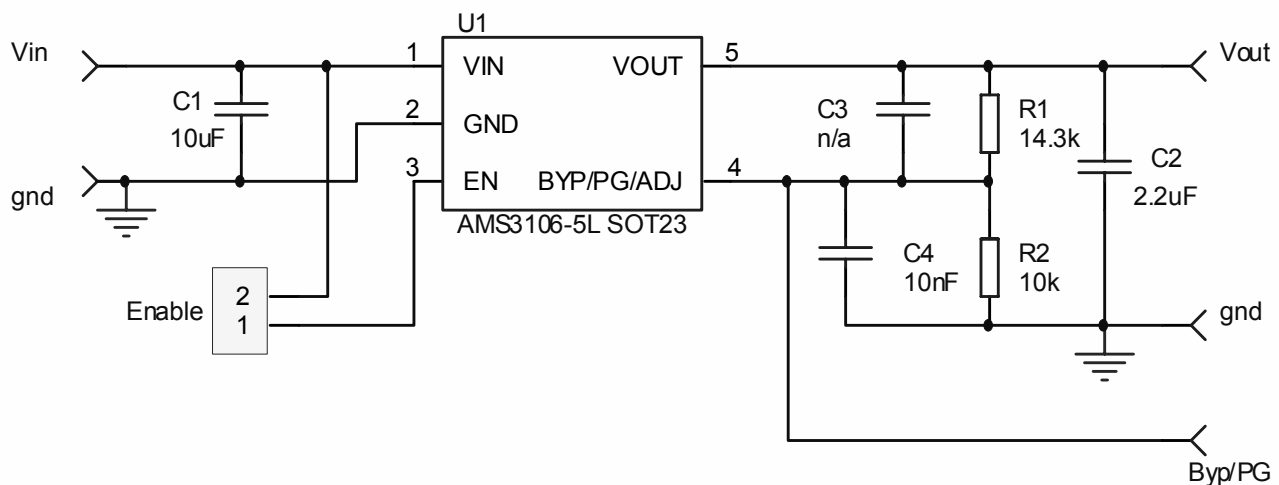

Figure 9: AMS3106 SOT23-5 Evaluation Board Schematic

Table 3: AMS3106 SOT23-5 Evaluation Board Bill of Materials

Component	Value	Manufacturer	Manufacturer Part Number	
C1	10 $\mu$ F, 50V, X5R, 1210, Ceramic	Taiyo Yuden	UMK325BJ106KM-T	
C2	2.2 $\mu$ F, 10V, X5R, 0805, Ceramic	Taiyo Yuden	LMK212BJ225MG-T	
C3	Optional Feedforward			
C4	10nF, 50V, 20%, X7R, 0603 Bypass Version Only.	Murata	GRM188R71H103MA01	
R1	1.2V	10.0k $\Omega$ , 0.1W, 0603 1%	Various	CRCW0603xxKxKFKEA
	1.8V	20.0k $\Omega$ , 0.1W, 0603 1%	Various	CRCW0603xxKxKFKEA
	2.5V	31.6k $\Omega$ , 0.1W, 0603 1%	Various	CRCW0603xxKxKFKEA
	3.3V	45.3k $\Omega$ , 0.1W, 0603 1%	Various	CRCW0603xxKxKFKEA
	5.0V	73.2k $\Omega$ , 0.1W, 0603 1%	Various	CRCW0603xxKxKFKEA
	PG	100k $\Omega$ , 0.1W, 0603 1% Power Good version Only.	Various	CRCW0603100KFKEA
R2	10.0k $\Omega$ , 0.1W, 0603 1%	Various	CRCW060310K0FKEA	
U1	Linear Regulator	AMS	AMS3106-5L SOT23	

## Micropower 500mA Low Noise Fast Transient Response LDO

### Ordering Information

Device	Package
AMS3106AS-XXBP <sup>(1)(2)(3)</sup>	SOIC-8 EDP
AMS3106S-XXBP <sup>(1)(2)(3)</sup>	SOIC-8 EDP
AMS3106AS-XXPG <sup>(1)(2)(3)</sup>	SOIC-8 EDP
AMS3106S-XXPG <sup>(1)(2)(3)</sup>	SOIC-8 EDP
AMS3106AS <sup>(1)(2)</sup>	SOIC-8 EDP
AMS3106S <sup>(1)(2)</sup>	SOIC-8 EDP

#### Notes:

1. Available in tape and reel only. A reel contains 2,500 devices.
2. Available in lead-free package only. Device is fully WEEE and RoHS compliant
3. Need to specify output voltage option ( )

### Outline Drawing and Landing Pattern

Package dimensions are inches (millimeters) unless otherwise noted.

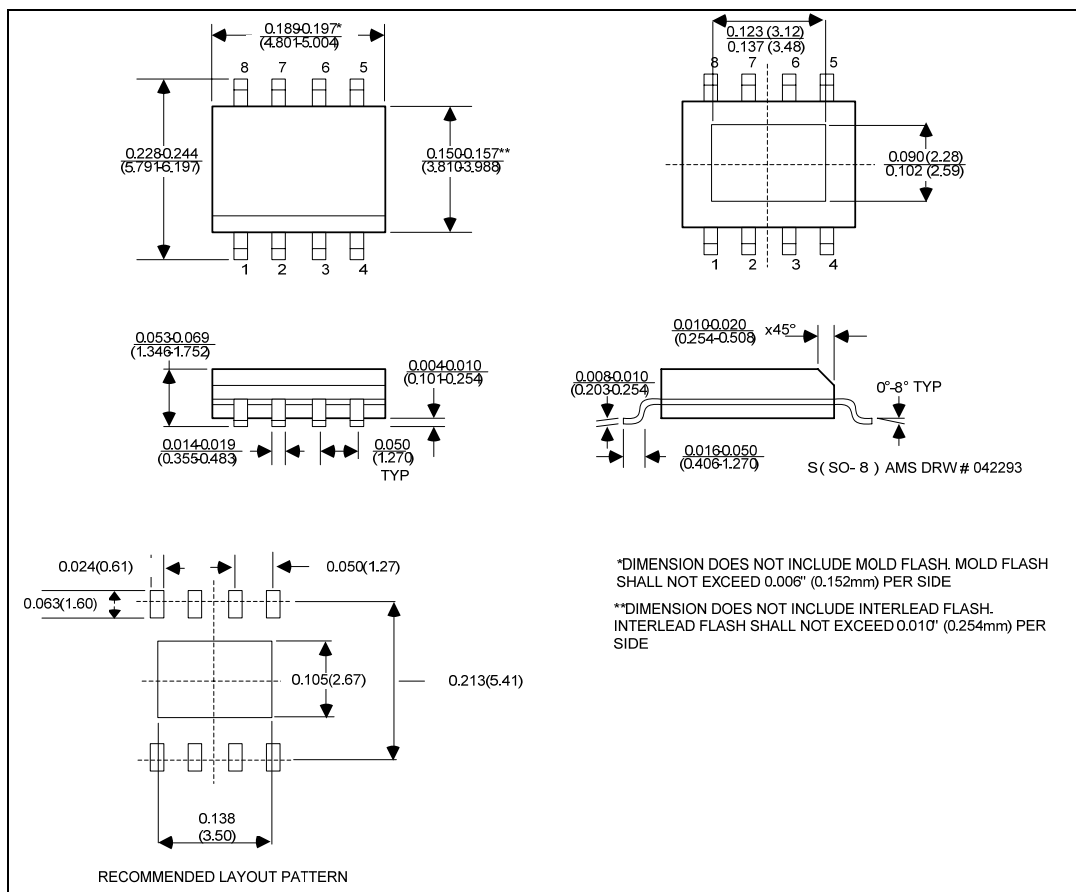

## Micropower 500mA Low Noise Fast Transient Response LDO

### Ordering Information

Device	Package
AMS3106AM1-XXBP <sup>(1)(2)(3)</sup>	5L SOT-23
AMS3106M1-XXBP <sup>(1)(2)(3)</sup>	5L SOT-23
AMS3106AM1-XXPG <sup>(1)(2)(3)</sup>	5L SOT-23
AMS3106M1-XXPG <sup>(1)(2)(3)</sup>	5L SOT-23
AMS3106AM1 <sup>(1)(2)</sup>	5L SOT-23
AMS3106M1 <sup>(1)(2)</sup>	5L SOT-23

#### Notes:

1. Available in tape and reel only. A reel contains 2,500 devices.
2. Available in lead-free package only. Device is fully WEEE and RoHS compliant
3. Need to specify output voltage option ( )

### Outline Drawing and Landing Pattern

Package dimensions are inches (millimeters) unless otherwise noted.

