

3A 20V Step-Down Converter + 1A LDO

General Description

The AMS4123 combines a 3A Step-Down converter with a 1A LDO in a single SO-8 exposed paddle package. Both the LDO and Step-Down converter are low ESR, ceramic capacitor output, stable. The Step-Down converter is internally compensated with internal soft-start to minimize the number of external components. An Enable pin provides built-in externally programmable power-up sequencing. The Step-Down converter enable threshold is 2.0V and the LDO enable threshold is 2.5V. It also has hiccup current limit and thermal protection. Thermal protection shuts down both the Step-Down converter and LDO when the die temperature exceeds 135°C. Both regulators are adjustable using a 0.6V reference for low output voltage settings. The LDO has options for fixed output voltages from 0.6V to 5V in 100mV steps. The LDO external input can be powered from the Step-Down converter output, for improved efficiency, or from any voltage source that is less than or equal to the device supply voltage (V_{in}). With a dropout voltage of less than 350mV at 1A, the AMS4123 LDO makes the perfect solution for a low noise 1.8V power source developed from 2.5V Step-Down converter output. The AMS4123 is a complete solution for LCD TV power requirements when combined with the AMS4122 (2A Dual Switching Regulator in SO-8).

Features

- Step-Down Converter + LDO in SO-8EP
- Internally Compensated
- Up to 95% Efficiency
- Low ESR Ceramic Output Capacitor Stable
- Soft Start
- Under-Voltage Lockout
- Dual Threshold Enable
- 300 kHz Switching Frequency
- Hiccup Current Limit
- Over-Temperature Shutdown
- Ultra-Low Dropout LDO 350mV @ 1A
- Up to 3A Step-Down Output Current
- Up to 1A LDO Output Current
- Excellent Light Load Efficiency

Applications

- Audio Power Amplifiers
- Portable (Notebook) Computers
- Point of Regulation for High Performance Electronics
- Consumer Electronics
- DVD, Blue-ray DVD writers
- LCD TVs and LCD monitors
- Distributed Power Systems
- Battery Chargers
- Pre-Regulator for Linear Regulation

Typical Application

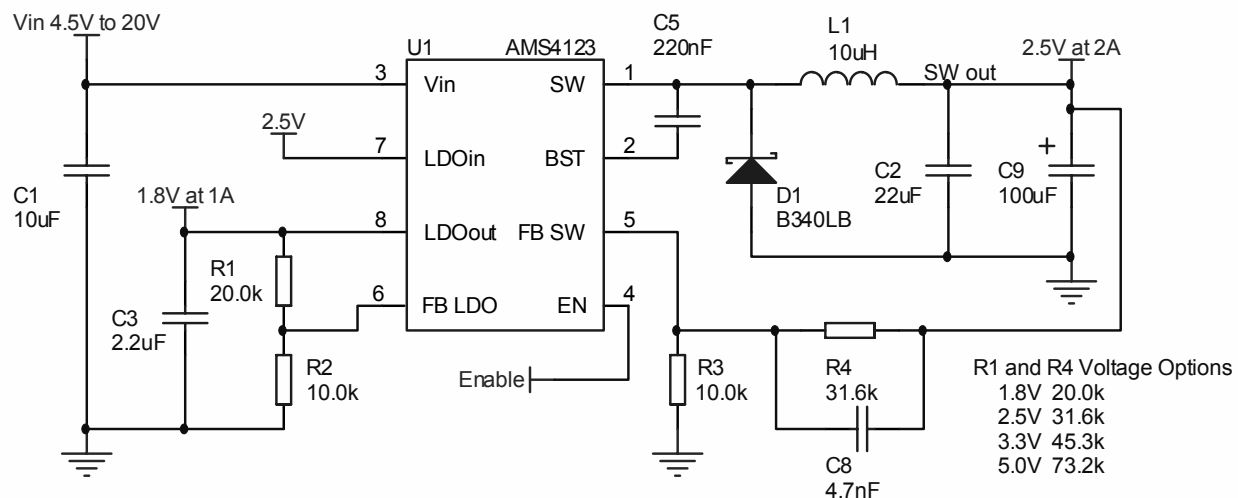

Pin Description

Pin #	Symbol	Description
1	SW	Step-Down converter switching node that connects the internal power switch to the output inductor.
2	BST	The bootstrap capacitor tied to this pin is used as the bias source for the drive to the internal power switch. Use a 220nF or greater capacitor from the BST to the SW pin.
3	Vin	Input Power. Supplies bias to the IC and is also the power input to the step-down converter main power switch. Bypass Vin with low impedance ceramic with sufficient capacitance to minimize switching frequency ripple as well as high frequency noise.
4	EN	Enable. A voltage greater than 2V at this pin enables the switching regulator. 2.5V enables the LDO section.
5	FB SW	Step-Down Converter Feedback input. A resistor network of two resistors is used to set-up the output voltage connected between $V_{SW\ out}$ and GND. The node between the two resistors is connected to Feedback Switch pin.
6	FB LDO	LDO Feedback input. A resistive voltage divider is used to set the output voltage connected between the LDO output and GND. The node between the two resistors is connected to FB LDO pin.
7	LDO in	LDO Input. Connect to the output of the Step-Down converter. LDO IN can also be powered from any power supply as long as it is 2V less than Vin.
8	LDO out	LDO Output pin.
9	GND (PADDLE)	Ground paddle to be connected to PCB ground plane. This is also the ground for internal voltage reference.

Pin Configuration

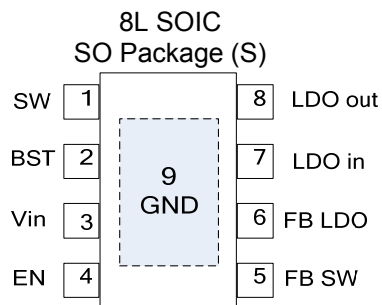

Top View

3A 20V Step-Down Converter + 1A LDO

Absolute Maximum Ratings ⁽¹⁾

V _{IN} Supply Voltage.....	-0.3V to 23V
LDO _{IN} Supply Voltage.....	-0.3V to 20V
LDO _{OUT} Output Voltage.....	-0.3V to 20V
BST Boot Strap Voltage.....	-0.3V to 27V
FBLDO,FBSW feedback pins.....	-0.3V to +12V
EN Enable Voltage.....	-0.3V to +20V
Storage Temperature Range.....	-65°C to 150°C
Lead Temperature.....	260°C
Junction Temperature.....	150°C

Recommended Operating Conditions ⁽²⁾

Input Voltage.....	4.5V to 20V
Ambient Operating Temperature.....	-40°C to 85°C

Thermal Information

8L SOIC EP θ_{JA} ⁽³⁾	45°C/W
θ_{JC}	10°C/W
Maximum Power Dissipation.....	2W

Electrical Characteristics T_A= 25 °C and V_{IN}=12V (unless otherwise noted).

Parameter	Symbol	Conditions	Min.	Typ.	Max.	Units
V _{in}	V _{in}		4.5	12	20	V
LDO Feedback Voltage	V _{FBLDO}	I _{LDO} =0A	tbd	0.586	tbd	V
Switcher Feedback Voltage	V _{FBSW}	I _{sw} =0A	tbd	0.596	tbd	V
LDO Output Voltage tolerance	V _{LDO Out}	V _{LDO out} =0.6V to 5V in 100mV increments	-1.5	1	1.5	%
Step-Down Converter Bias Current	I _{QSW}	V _{LDOin} = V _{EN} = 5V V _{FBSW} = 1.5V		1.4	1.9	mA
LDO+SW Bias Current	I _{QSW+LDO}	V _{LDOin} = V _{EN} = 5V V _{FBLDO} = V _{FBSW} = 1.5V		1.3	2.0	mA
LDO Bias Current	I _{QLDO}	V _{EN} = 5V; V _{FBLDO} = 1.5V		400		μA
Shutdown Supply Current	I _{Vinsd}	V _{EN} = 0V		90		nA
SW NPN Saturation Voltage	V _{SAT}	I _{SW out} =1A		0.66		V
Converter Current Limit	I _{LIMSW}	V _{SW out} =5V		4.2		A
LDO Current Limit	I _{LIMLDO}	V _{LDO in} =5V; C _o =2.2μF		1.1		A
LDO Dropout Voltage	V _{DO}	V _{LDOin} =V _{LDOout} -0.1V, I _o =1A		350		mV
LDO Load Regulation	$\frac{\Delta V_{LDO Out}}{V_{LDO Out}}$	I _{LDO} = 0 to 1A		0.5		%
LDO Line Regulation	$\frac{\Delta V_{LDO Out}}{V_{LDO Out}}$	V _{LDOin} = V _{LDOout} +0.5V to 20V, V _{in} =20V		0.1		%
Oscillator Frequency	F _{OSC}		260	300	340	kHz
Maximum Duty Cycle	D _{MAX}	V _{FB} =0V		95	99	%
Minimum Duty Cycle	D _{MIN}	V _{FB} =1.5V		0		%
Converter Enable Threshold	V _{EN SW}			2.0	2.1	V
Enable Hysteresis	V _{ENHYS}			100		mV
LDO Enable Threshold	V _{EN LDO}			2.5	2.55	V
Enable Pull-up Current	I _{EN}	V _{EN} = 0V		0.7		μA
Under Voltage Lockout	V _{UVLO}	V _{in} rising		4.2		V
Under Voltage Lockout Hysteresis	V _{UVLO HYS}			200		mV
Total Power dissipation	P _D	Note (4)		2.5		W
Thermal Shutdown	T _{SD}			145		°C

3A 20V Step-Down Converter + 1A LDO

Notes:

1. Stresses above those listed in Absolute Maximum Ratings may cause permanent damage to the device.
2. Operation outside of the recommended operating conditions is not guaranteed.
3. Measured on approximately 1" square of 1 oz. copper.
4. The total power dissipation for SO-8 EDP package is recommended to 2.5W rated at 25°C ambient temperature. The thermal resistance Junction to Case is 45°C/W. Total power dissipation for the switching regulator and the LDO should be taken in consideration when calculating the output current capability of each regulator.

Typical Characteristics

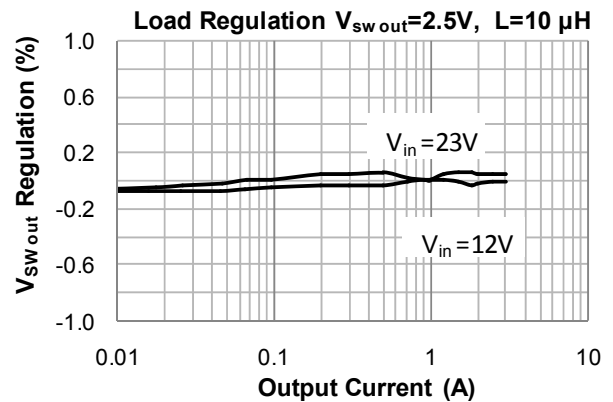
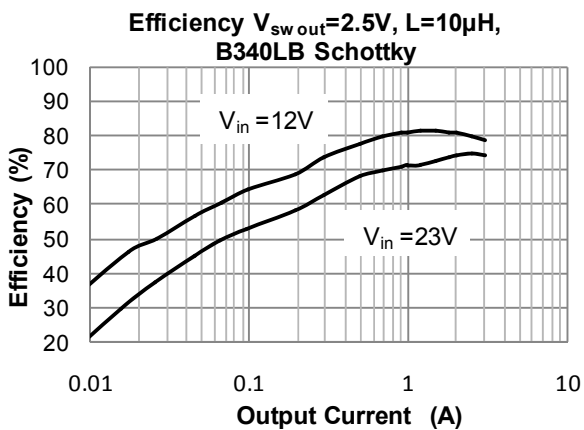
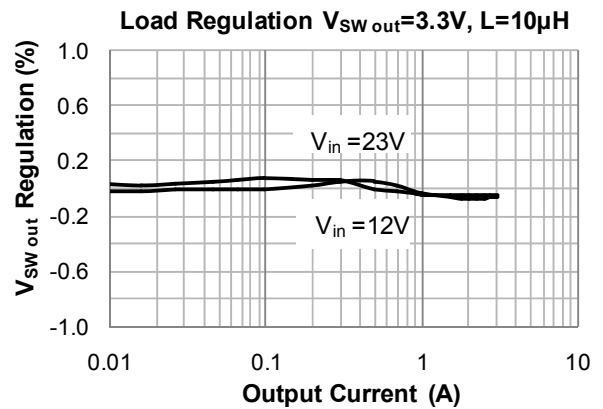
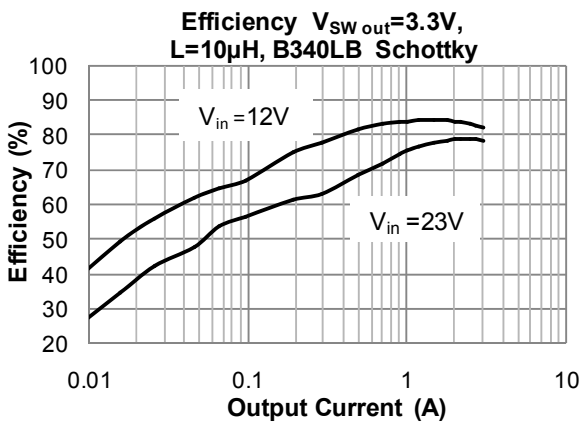
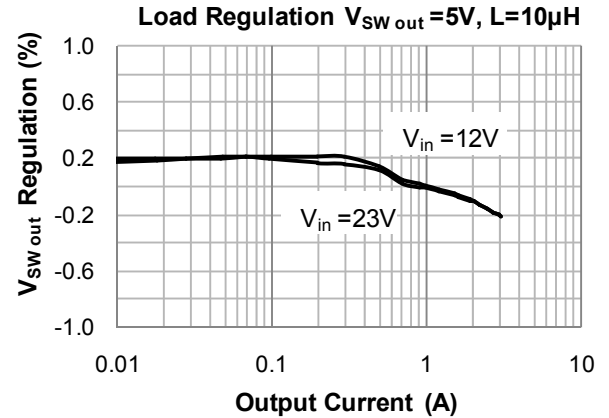
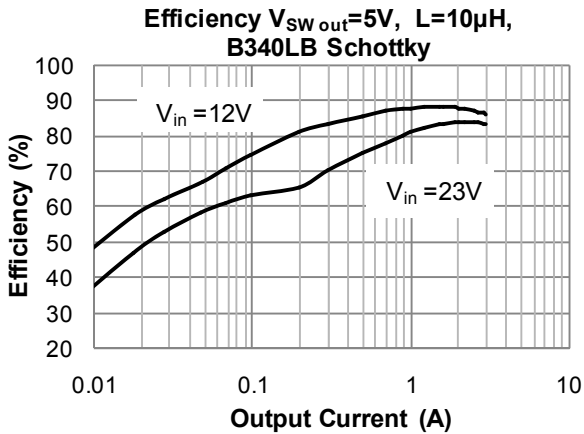

Typical Characteristics

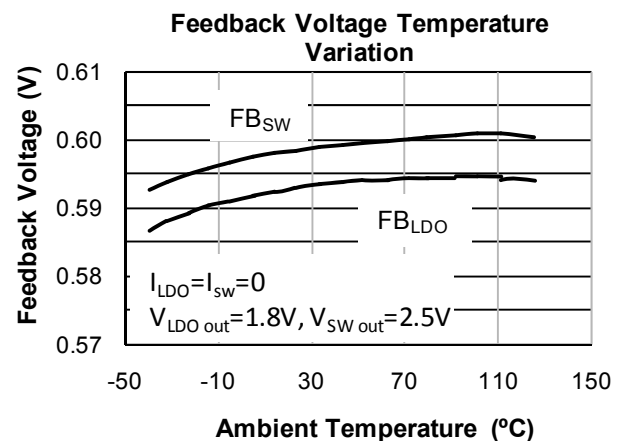
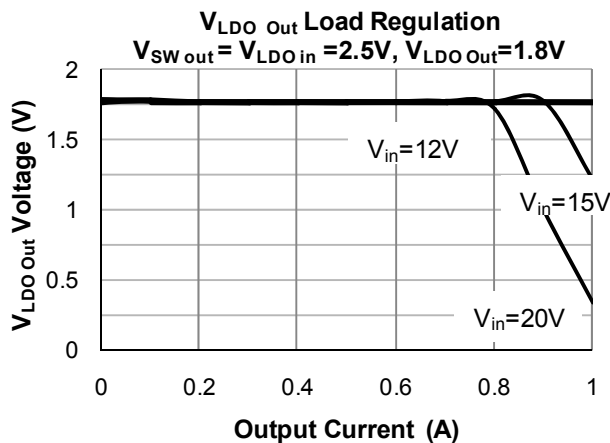
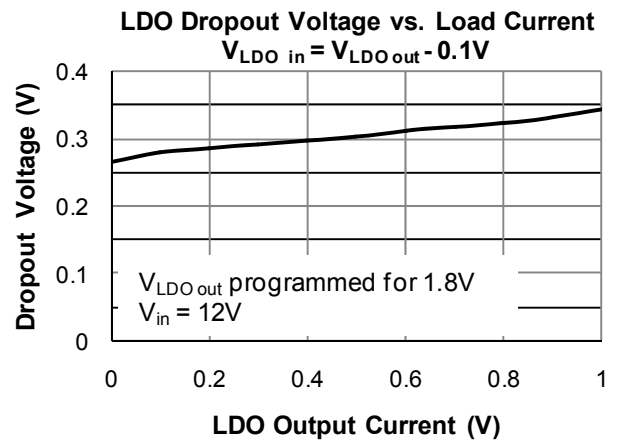
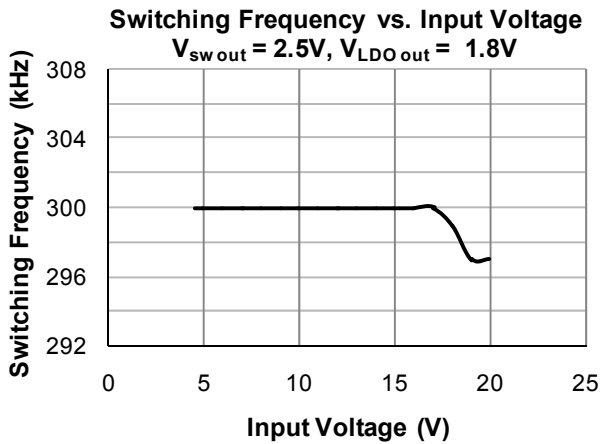
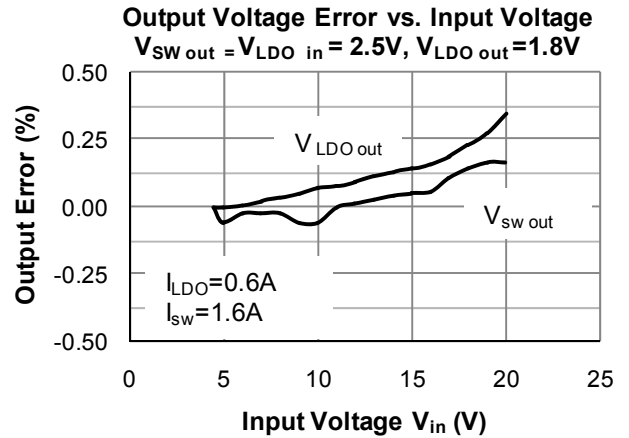
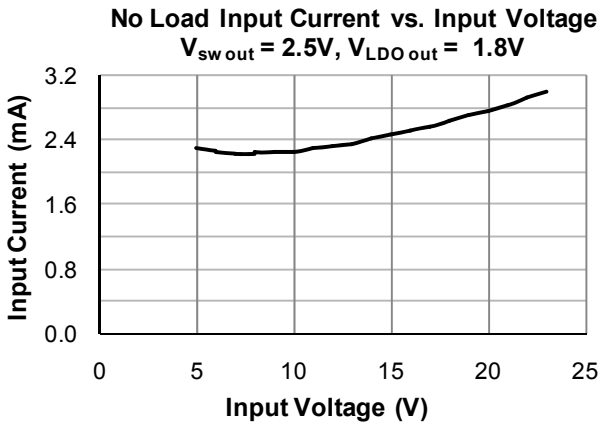

Typical Characteristics

Step-Down Converter Output Ripple
 $V_{SW\ out} = 2.5V, I_{SW\ out} = 1.8A, V_{in} = 12V$

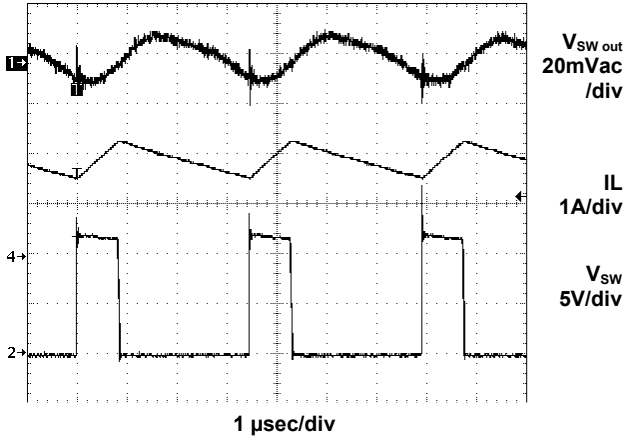

LDO 200mA to 800mA Transient Response,
 $V_{LDO\ in} = 3.3V, C_o = 2.2\mu F, V_{LDO\ out} = 1.8V, V_{in} = 12V$

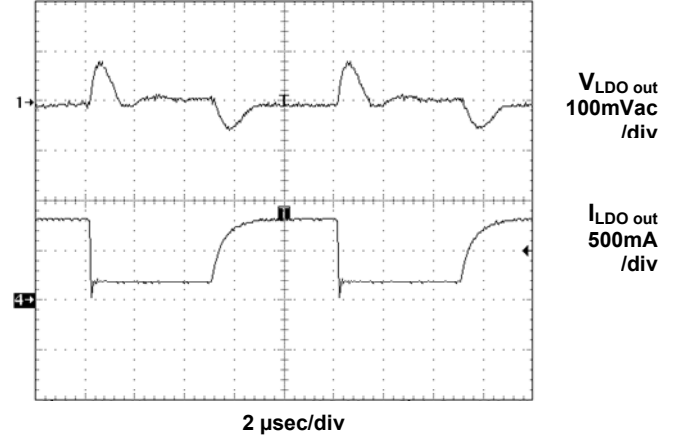

Step-Down Converter Load Transient
 No Load to 2A, $V_{SW\ out} = 2.5V, V_{in} = 12V$

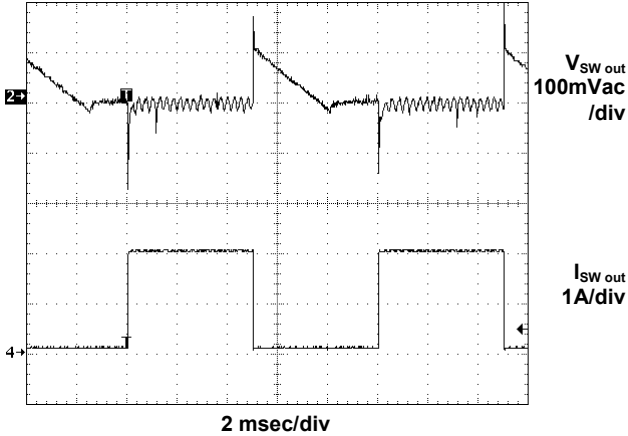

Step-Down Converter Load Transient
 200mA to 2A, $V_{SW\ out} = 2.5V, V_{in} = 12V$

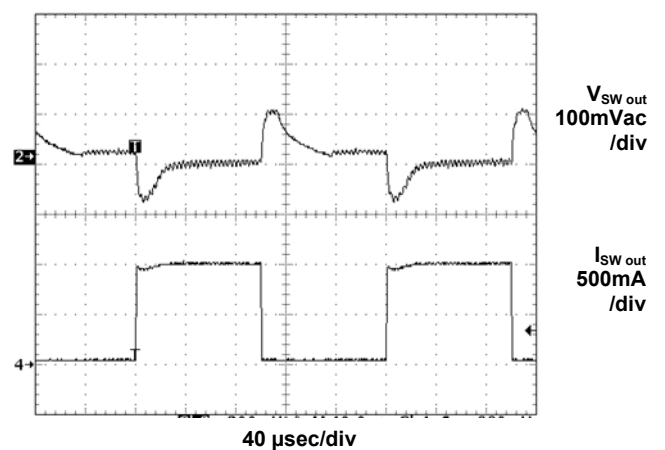

LDO Transient Response
 No Load to 1A, $V_{LDO\ in} = V_{SW\ out} = 2.5V,$

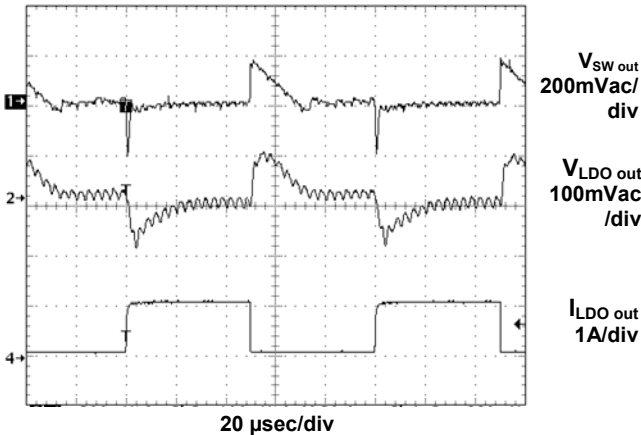

Step-Down Converter Load Transient
 200mA to 1.2A, $V_{SW\ out} = 2.5V, V_{in} = 12V$

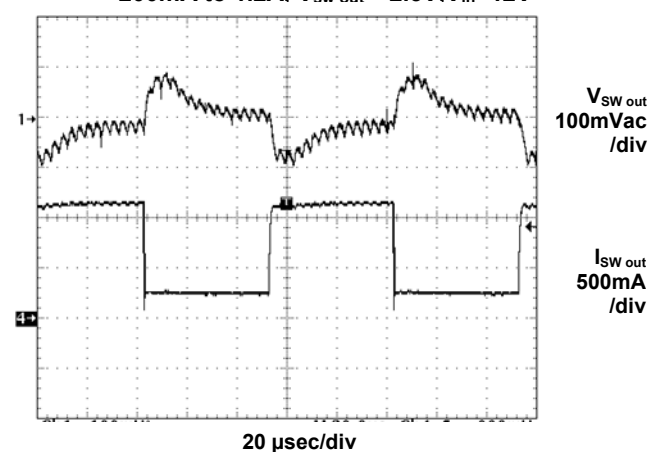

Typical Characteristics

Start-Up Response $V_{in}=12V$

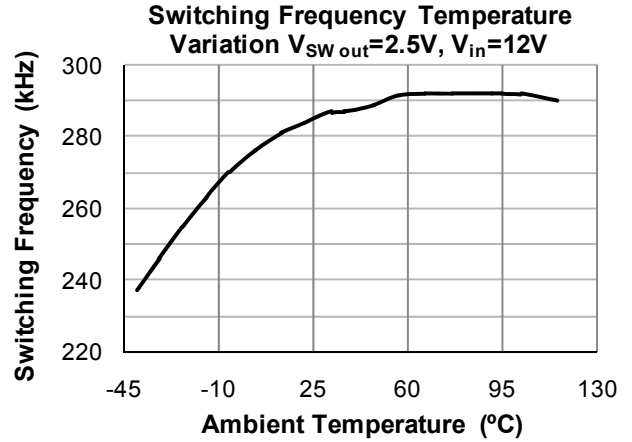
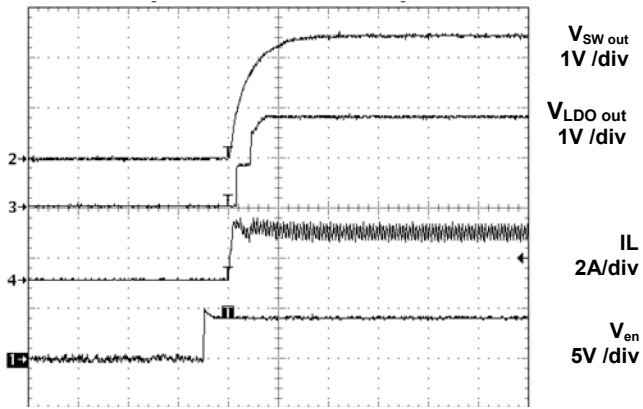

Start-Up Response Enable= $V_{in}=12V$

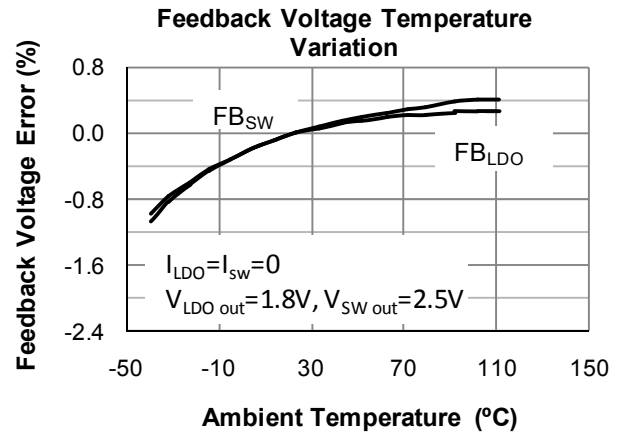
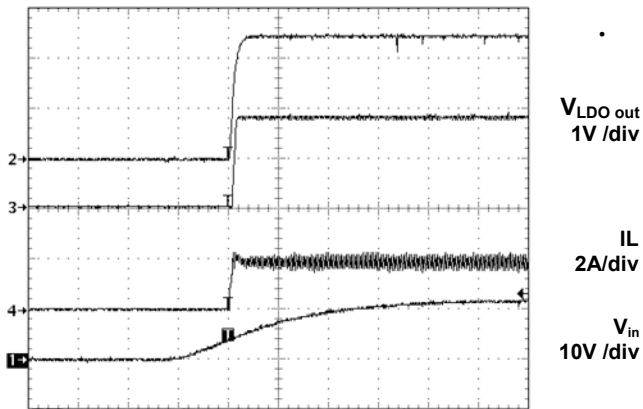

Start-Up Response $V_{in}=20V$

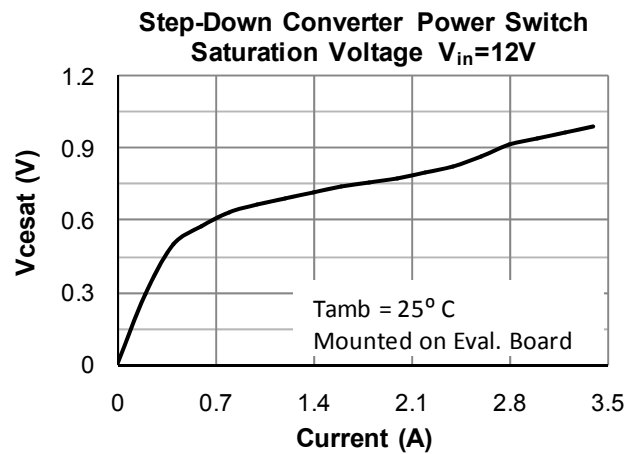
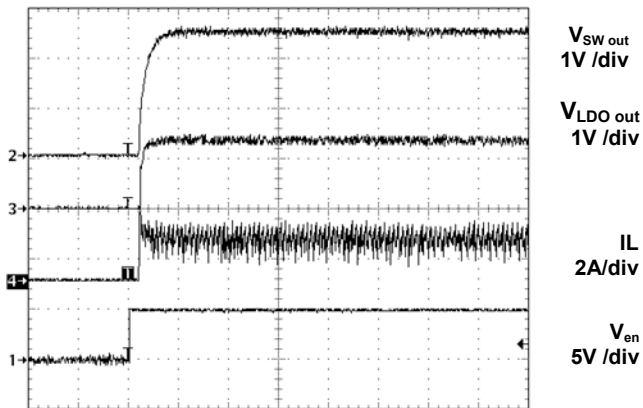

Typical Characteristic

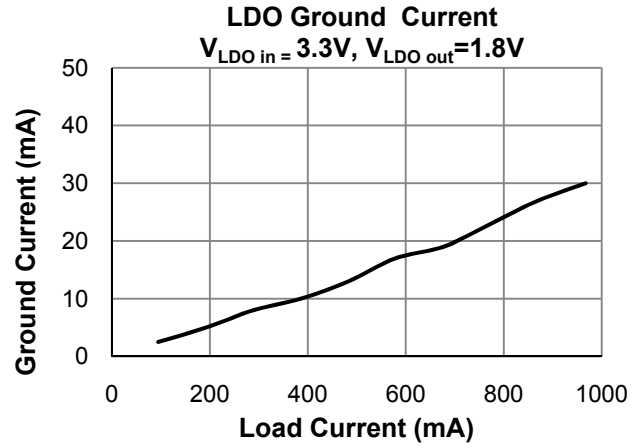
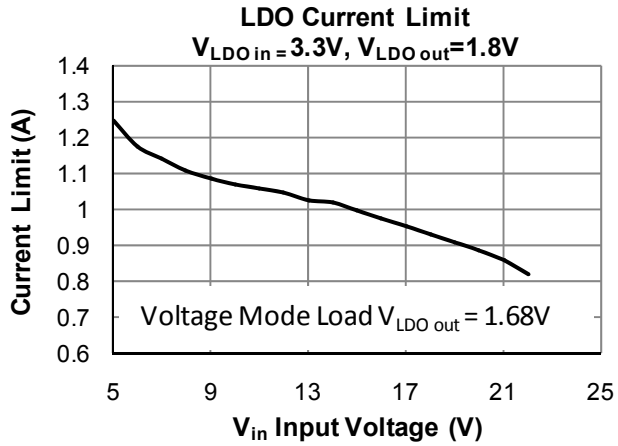

Functional Block Diagram

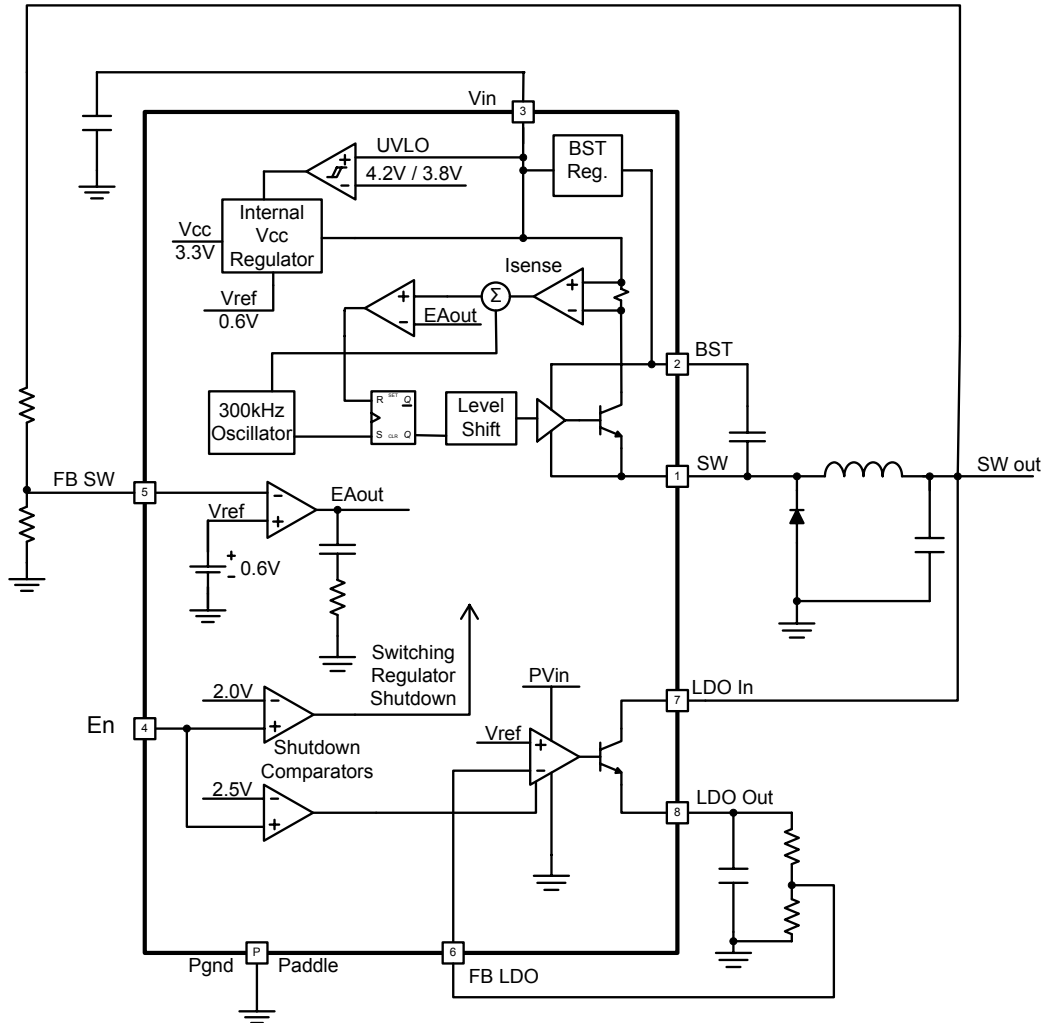

3A 20V Step-Down Converter + 1A LDO

Device Summary

The AMS4123 is combines a high voltage 3 Amp fixed frequency step-down converter combined with a 1 Amp low drop out (LDO) linear regulator on a single die.

The peak current mode step-down converter has internal compensation and is stable with a wide range of ceramic, tantalum, and electrolytic output capacitors. The step-down converter output voltage is sensed through an external resistive divider that feeds the negative input to an internal transconductance error amplifier. The output of the error amplifier is connected to the input to a peak current mode comparator. The inductor current is sensed as it passes through the power switch, amplified and is also fed to the current mode comparator. The error amplifier regulates the output voltage by controlling the peak inductor current passing through the power switch so that, in steady state, the average inductor current equals the load current. The step-down converter has an input voltage range of 4.5V to 20V with an output voltage as low as 0.6V.

The LDO operates from an input voltage ranging from 1V to 20V and a typical dropout voltage of 350mV at 1A. The input to the LDO can be supplied by the output of the Step-Down converter or some other available power source that must be 2V less than the input voltage (V_{in}). The LDO is also stable for a wide range of ceramic output capacitors ranging from as low as 1 μ F.

Enable

The enable input has two levels so that the step-down converter can be enabled independently of the LDO. The enable threshold for the step-down converter is 2.0V while the enable threshold for the linear regulator output is 2.5V typical.

Under Voltage Lockout

The under-voltage lockout (UVLO) feature guarantees sufficient input voltage (V_{in}) bias for proper operation of all internal circuitry prior to activation. The input voltage (V_{in}) is internally monitored and the converter and LDO are enabled when the rising level of V_{in} reaches 4.2V. To prevent UVLO chatter 400mV of hysteresis is built in to the UVLO comparator so that the step-down converter and LDO are disabled when V_{in} drops to 3.8V.

Fault Protection

Short circuit and over-temperature shutdown disable the converter and LDO in the event of an overload condition.

Application

Inductor

The step-down converter inductor is typically selected to limit the ripple current to 40% of the full load output current. Solve for this value at the maximum input voltage where the inductor ripple current is greatest.

$$L = (V_{in} - V_o) \cdot \frac{V_o}{V_{in} \cdot I_o \cdot 0.4 \cdot F_s}$$

$$L = (15V - 2.5V) \cdot \frac{2.5V}{15V \cdot 2A \cdot 0.4 \cdot 300kHz} = 9.4\mu H$$

For most applications the duty cycle of the AMS4123 step down converter is less than 50% duty and does not require slope compensation for stability. This provides some flexibility in the selected inductor value. Given the above selected value, others values slightly greater or less may be examined to determine the effect on efficiency without a detrimental effect on stability.

With an inductor value selected, the ripple current can be calculated:

$$I_{pp} = \frac{(V_o + V_{fwd}) \cdot (1 - D)}{L \cdot F_s}$$

Using the maximum input voltage values the ripple is:

$$I_{pp} = \frac{(2.5V + 0.2V) \cdot (1 - 0.23)}{10\mu H \cdot 300kHz} = 0.7A$$

Once the appropriate value is determined, the component is selected based on the DC current and the peak (saturation) current. Select an inductor that has a DC current rating greater than the full load current of the application. The DC current rating is also reflected in the DC resistance (DCR) specification of the inductor. The inductor DCR should limit the inductor loss to less than 2% of the step-down converter output power.

The peak current at full load is equal to the full load DC current plus one half of the ripple current. As mentioned before, the ripple current varies with input

3A 20V Step-Down Converter + 1A LDO

voltage and is a maximum at the maximum input voltage.

$$I_{pkmax} = I_o + \frac{(V_o + V_{fwd}) \cdot (1 - D_{min})}{2 \cdot L \cdot F_s}$$

$$D_{min} = \frac{V_o}{V_{inmax}}$$

The duty cycle can be more accurately estimated by including the drops of the external Schottky diode and the internal power switch:

$$D_{min} = \frac{V_o + V_{fwd}}{V_{inmax} - V_o + V_{fwd}}$$

$$D_{min} = \frac{2.5V + 0.2V}{15V - 0.3V + 0.2V} = 0.23$$

V_{fwd} is the diode freewheeling diode drop and V_{sw} is the collector to emitter drop of the internal power switch.

With a good estimate of the duty cycle (D) the inductor peak current can be determined:

$$I_{pkmax} = 2A + \frac{(2.5V + 0.2V) \cdot (1 - 0.23)}{2 \cdot 10\mu H \cdot 300kHz} = 2.35A$$

There are a wide range 2 and 3 Amp, shielded and non-shielded inductors available. Table 1 lists a few.

Table 1. Inductor Selection Guide

Series	Type	Dimensions (mm)		
		W	L	H
Coilcraft				
DO3316P	Non-Shielded	9.4	13	5.2
DO3308	Non-Shielded	9.4	13	3.0
Sumida				
CDRH6D26	Shielded	7	7	2.8
CDH74	Non-Shielded	7.3	7.3	5.2
Coiltronics				
SD8328	Shielded	8.3	9.5	3.0

Step-Down Converter Output Capacitor

The optimum solution for the switching regulator is to use a large bulk capacitor for large load transients in parallel with a smaller, low ESR, X5R or X7R ceramic capacitor to minimize the switching frequency ripple.

High Frequency Ripple

The following equation determines the required low ESR ceramic output capacitance for a given inductor current ripple (I_{pp}).

$$C = \frac{I_{pp}}{F_s \cdot \Delta V} = \frac{0.7A}{300kHz \cdot 8 \cdot 20mV} = 15\mu F$$

Large Signal Transient

For applications with large load transients an additional capacitor may be required to keep the output voltage within the limits required during large load transients.

In this case the required capacitance can be examined for the load application and load removal. For full load to no load transient the required capacitance is

$$C_{bulk} = \frac{L \cdot I_o^2}{V_{os}^2 - V_o^2} = \frac{10\mu H \cdot (2A)^2}{(2.7V)^2 - (2.5V)^2} = 36\mu F$$

For the application of a load pulse the capacitance required form hold up depends on the time it takes for the power supply loop to build up the inductor current to match the load current. For the AMS4123 this can be estimated to be less than 10 μ sec or about three clock cycles.

$$C_{bulk} = \frac{I_o \cdot t}{\Delta V} = \frac{2A \cdot 10\mu sec}{0.2V} = 100\mu F$$

For applications that do not have any significant load transient requirements a ceramic capacitor alone is typically sufficient.

Boot Strap Capacitor

An external capacitor is required for the high side switch drive. The capacitor is biased during the off time while the switch node is at ground by way of the freewheeling diode. During the on time portion of the switching cycle the switch node is tied to the input voltage by way of the internal power switch. The boot strap capacitor is always referenced to the switch node so the charge stored in the capacitor during the off time is then used to drive the internal power switch during the on time.

3A 20V Step-Down Converter + 1A LDO

Typical bootstrap capacitor values are in the 220nF to 470nF range. Insufficient values will not be able to provide sufficient base drive current to the power switch during the on time. Values less than 220nF are not recommended. This will result in excessive losses and reduced efficiency.

Optional Snubber

To reduce high frequency ringing at the switching node a snubber network is suggested. The values typically selected are 470pF ceramic in series with a 10Ω resistor. The power dissipation of the 10Ω resistor is about 32mW for a 15V input with a 300kHz switching frequency.

$$P_{R1} = C3 \cdot V_{in}^2 \cdot F_{sw}$$

V_{in} is the maximum input voltage and F_{sw} is the switching frequency. The snubber capacitor must be rated to withstand the input voltage.

Step-Down Converter Input Capacitor

The low esr ceramic capacitor required at the input to filter out high frequency noise as well as switching frequency ripple. Placement of the capacitor is critical for good high frequency noise rejection. See the PCB layout guidelines section for details. Switching frequency ripple is also filtered by the ceramic bypass input capacitor. Given a desired input voltage ripple (V_{ripple}) limit, the required input capacitor can be estimated with:

$$D_{max} = \frac{V_o + V_{fwd}}{V_{inmin} - V_o + V_{fwd}}$$

$$C = \frac{D_{max} \cdot I_o \cdot (1 - D_{max})}{F_s \cdot V_{ripple}}$$

$$= \frac{\left(\frac{2.5V + 0.2V}{9V - 0.3V + 0.2V}\right) \cdot 2A \cdot \left(1 - \frac{2.5V + 0.2V}{9V - 0.3V + 0.2V}\right)}{300kHz \cdot 0.2V} = 7\mu F$$

For high voltage input converters the duty cycle is always less than 50% so the maximum ripple is at the minimum input voltage. The ripple will increase as the duty cycle approaches 50% where it is a maximum.

Step-Down Converter Feedforward Capacitor

For optimum start-up and improved transient response place a feed-forward capacitor ($C6$) across the feedback resistor $R2$. Typical values range from 220pF to 10nF.

Linear Regulator Output Capacitor

The Linear regulator is stable with a wide range of ceramic capacitors. The ceramic output capacitor can range from 1uF to 100uF with either X5R or X7R temperature coefficient. The actual values selected within the range will depend on the expected load transients and the output voltage tolerance requirements during the load transient.

Linear Regulator Input Capacitor

Place a 2.2uF X5R or X7R or equivalent ceramic bypass capacitor at the LDO input.

Feedback Resistor Selection

The step down converter and LDO both use a 0.6V reference voltage at the positive terminal of the error amplifier. To set the output voltage a programming resistor from the feedback node to ground must first be selected ($R2, R3$ of figure 4). A 10kΩ resistor is a good selection for a programming resistor. A higher value could result in an excessively sensitive feedback node while a lower value will draw more current and degrade the light load efficiency. The equation for selecting the voltage specific resistor is:

$$R4 = \left(\frac{V_{out}}{V_{ref}} - 1\right) \cdot R3 = \left(\frac{2.5V}{0.6V} - 1V\right) \cdot 10k\Omega = 31.67k\Omega$$

Table 2. Feedback Resistor values

Vout (V)	R1,R4 (kΩ) (R2,R3=10kΩ)
1.8	20.0
2.5	31.6
3.3	45.3
5.0	73.2

PCB Layout

The following guidelines should be followed to insure proper layout.

1. Vin Capacitor. A low ESR ceramic bypass capacitor must be placed as close to the IC as possible.
2. Schottky Diode. During the off portion of the switching cycle the inductor current flows through the Schottky diode to the output cap and returns to the inductor through the output capacitor. The trace that connects the output diode to the output capacitor sees a current signal with a very high di/dt . To minimize the associated spiking and ringing, the inductance and resistance of this trace should be minimized by connecting the diode anode to the output capacitor return with a short wide trace.
3. Feedback Resistors. The feedback resistors should be placed as close as possible to the IC. Minimize the length of the trace from the feedback pin to the resistors. This is a high impedance node susceptible to interference from external RF noise sources.
4. Inductor. Minimize the length of the SW node trace. This minimizes the radiated EMI associated with the SW node.
5. Ground. The most quiet ground or return potential available is the output capacitor return. The inductor current flows through the output capacitor during both the on time and off time, hence it never sees a high di/dt . The only di/dt seen by the output capacitor is the inductor ripple current which is much less than the di/dt of an edge to a square wave current pulse. This is the best place to make a solid connection to the IC ground and input capacitor. This node is used as the star ground shown in Figure 1. This method of grounding helps to reduce high di/dt traces, and the detrimental effect associated with them, in a step-down converter. The inductance of these traces should always be minimized by using wide traces, ground planes, and proper component placement.
6. For good thermal performance vias are required to couple the exposed tab of the SO-8 package to the PCB ground plane. The via diameter should be 0.3mm to 0.33mm positioned on a 1.2mm grid.

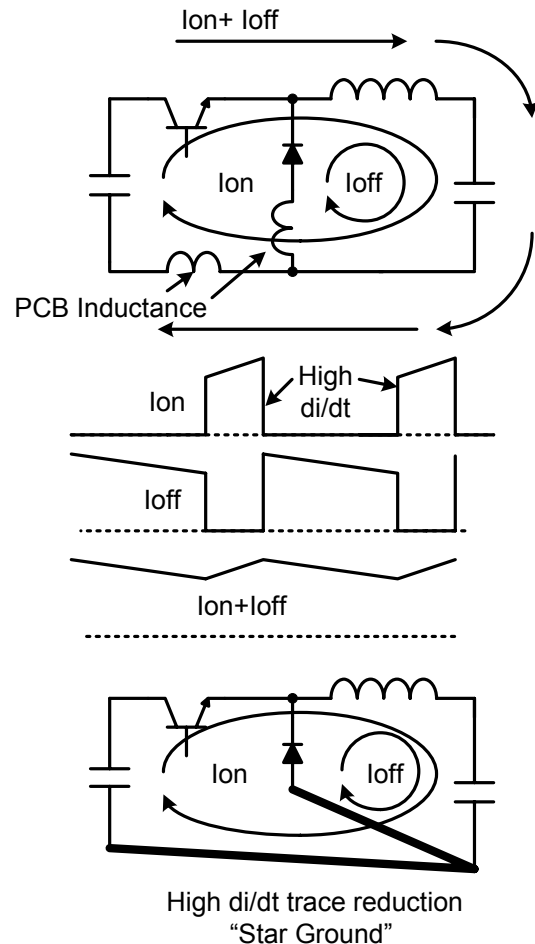

Figure 1. Step Down Converter Layout

Output Power and Thermal Limits

The AMS4123 junction temperature, Step-Down converter and LDO current capability depends on the internal dissipation and the junction to case thermal resistance of the SO8 exposed paddle package. This gives the junction temperature rise above the device paddle and PCB temperature.

The temperature of the paddle and PCB will be elevated above the ambient temperature due to the total losses of the step down converter and losses of other circuits and or converters mounted to the PCB.

$$T_{jmax} = P_d \cdot \theta_{jc} + T_{pcb} + T_{amb}$$

The losses associated with the AMS4123 overall efficiency are;

1. Output Diode Conduction Losses
2. Inductor DCR Losses
3. AMS4123 Internal losses
 - a. Power Switch Forward Conduction and Switching Losses
 - b. Quiescent Current Losses

The internal losses contribute to the junction temperature rise above the case and PCB temperature.

The junction temperature depends on many factors and should always be verified in the final application at the maximum ambient temperature. This will assure that the device does not enter over-temperature shutdown when fully loaded at the maximum ambient temperature.

3A 20V Step-Down Converter + 1A LDO

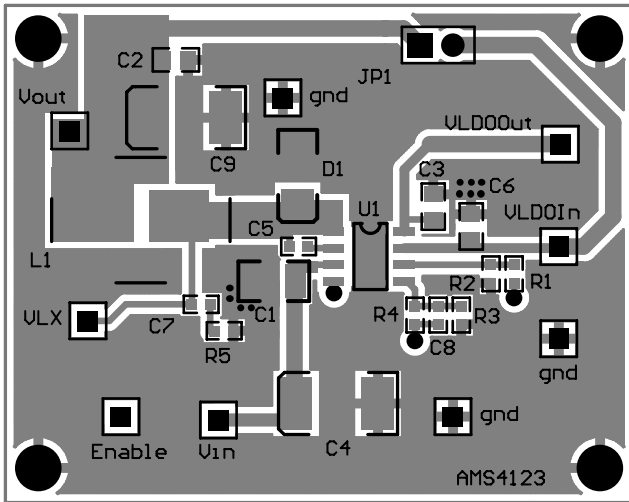

Figure 2. AMS4123 Evaluation Board Top Side

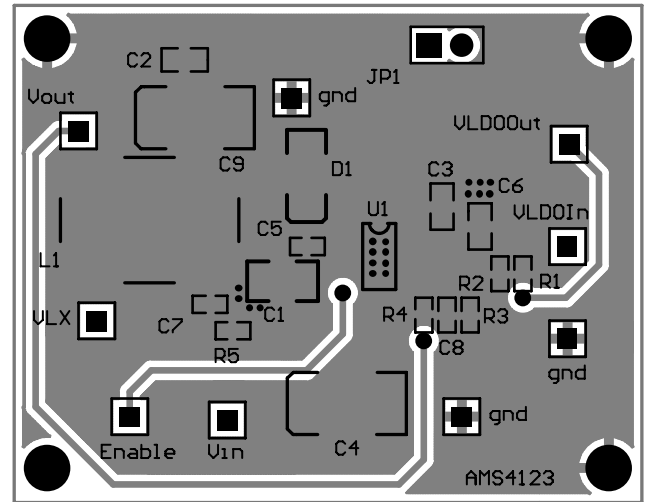

Figure 3. AMS4123 Evaluation Board Bottom Side

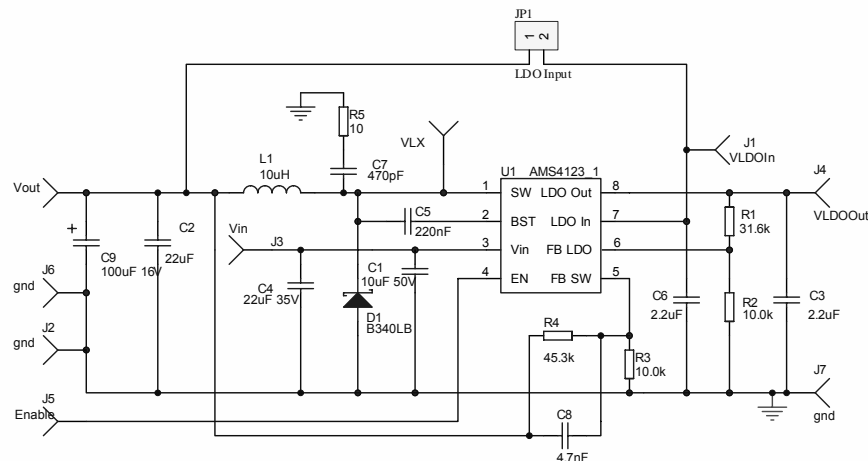

Figure 4. AMS4123 Evaluation Board Schematic

Table 3. Evaluation Board Bill of Materials

Component	Value	Manufacturer	Manufacturer Part Number
L1	10µH 3.9A 9.4mm x 13mm x 5.2mm	Coilcraft	DO3316P
C9	100µF, 16V, X case General Purpose Tantalum	Kemet	T491X107M016AS
C2	22µF, 10V, X5R, 0805, Ceramic	Taiyo Yuden TDK	LMK212BJ226MG-T C3225X5R1A226M
C1	10µF, 50V, X5R, 1210, Ceramic	Taiyo Yuden	UMK325BJ106KM-T
C3,C6	2.2µF, 10V, X5R, 0805	Murata	GRM216R61A225KE24
C3,C6 option	2.2µF, 10V, X5R, 0603	Murata	GRM39X5R225K10H52V
C7	470pF 50V, 20%, X7R, 0603	Murata	GRM188R71H471MA01
C5	220nF 25V, 10%, X7R, 0603	Murata	GRM188R71E224KA88
C8	4.7nF 50V, 20%, X7R, 0603	Murata	GRM188R71H472MA01
C4	22µF 35V Tantalum Case E	Vishay	293D226X9035E2TE3
R5	10Ω, 0.1W, 0603 5%	Vishay/Dale	CRCW060310R0JNEA

3A 20V Step-Down Converter + 1A LDO

R2,R3	10kΩ, 0.1W, 0603 1%	Various	CRCW060310K0FKEA
R1,R4	See table 2	Various	CRCW0603xxKxKEA
D1	3A, 40V Schottky	Diodes Inc.	B340LB
U1	Step-Down Converter / LDO	AMS	AMS4123

ORDERING INFORMATION

Package Type	TEMP. RANGE
SOIC EDP	
AMS4123S	-25°C to 125°C

PACKAGE DIMENSIONS inches (millimeters) unless otherwise noted.

8 LEAD SOIC PLASTIC PACKAGE (S)

