

#### FEATURES

- $\pm 2\%$  Voltage Threshold Accuracy
- Operating Voltage 1.4V to 15V
- Open collector output
- Low supply current – 0.9 $\mu$ A (typ)
- Guaranteed out assertion down to  $V_{CC} = 0.7V$
- Power Supply Transient Immunity
- Adjustable threshold voltage from 1.25V to 12V

#### APPLICATIONS

- CPU and Logic Circuit Reset
- Portable and Battery Powered Equipment
- Memory Battery Back-Up Circuit
- Window Comparator
- Cellular Phones
- Pagers

#### GENERAL DESCRIPTION

The AMS23 low power voltage detector provides monitoring of battery, power-supply, and regulated system voltages. A precision voltage reference and comparator monitors the  $V_{CC}$  input and compares it with a specified voltage threshold condition. When  $V_{CC}$  falls below a specified trip point threshold, the output (OUT) is forced low and remains asserted as long as the  $V_{CC}$  input remains below  $V_{TH} +$  hysteresis ( $V_{HYST}$ ). The AMS23 device is guaranteed to output the correct logic state for  $V_{CC}$  down to 0.7V. They are also designed to ignore fast transients on  $V_{CC}$ . This small, low power device is ideal for portable applications and is available in space-saving SOT23-5 package.

#### ORDERING INFORMATION

OUTPUT	PACKAGE	OPERATING
TYPE	TYPE	TEMPERATURE
	5 LEAD SOT-23	RANGE
OPEN COLLECTOR	AMS23M1	-40 to +85° C

#### PIN CONNECTIONS

##### 5L SOT-23 (M)

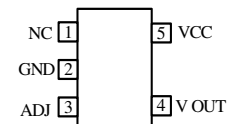

Top View

## ABSOLUTE MAXIMUM RATINGS

Supply Voltage	0.7 to 15	Storage Temperature	-55°C to 150°C
Output Current	20mA	Lead Solder Temperature for 25 secs.	265°C
Input or Output Voltage	-0.3 to VCC +0.3	Power Dissipation	320mW

## DC AND AC ELECTRICAL CHARACTERISTICS

Electrical Characteristics at  $T_A=25^\circ\text{C}$  and  $V_{CC}=3.3\text{V}$ , unless otherwise noted.

PARAMETER	CONDITIONS (Note 2)	AMS23			Units
		Min.	Typ.	Max.	
Operating Voltage		1.25		15	V
VCC Supply Current	$V_{CC} = 3.0\text{V}$ , No load		0.9	3.0	$\mu\text{A}$
	$V_{CC} = 5.5\text{V}$ , No load		1.1	3.6	$\mu\text{A}$
Output Current, NPN Collector	$V_{CC} = 1.5\text{V}$	1.0	3		mA
	$V_{CC} = 2.5\text{V}$	3.0	14		mA
<b>Voltage Thresholds</b>					
Detect Voltage		$V_{TH} - 2\%$	$V_{TH}$	$V_{TH} + 2\%$	V
Release Voltage			$V_{TH} + V_{HYST}$		V
Threshold Hysteresis		$0.2V_{TH}$	$0.05V_{TH}$	$0.08V_{TH}$	V
VCC to OUT Detect Delay	$V_{CC}$ falling from $(V_{TH} + 100\text{mV})$ to $(V_{TH} - 100\text{mV})$ at $10\text{mV}/\mu\text{s}$		2		$\mu\text{s}$
Threshold Temperature Coefficient			$\pm 100$		ppm/°C

**Note 1:** Valid for Ambient Operating Temperature:  $T_A = 25^\circ\text{C}$ .

## BLOCK DIAGRAM

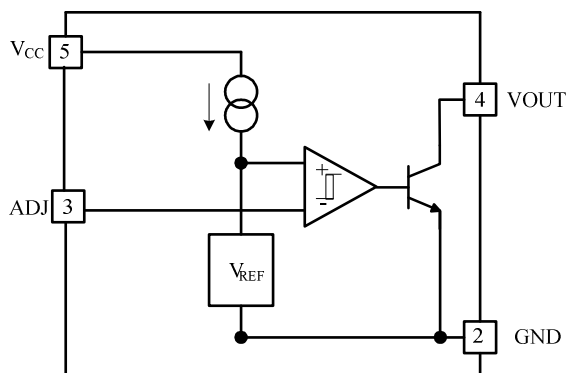

## PIN DESCRIPTIONS

AMS23		
PIN NUMBERS	NAME	DESCRIPTION
1	NC	Not Connect
2	GND	Ground is the reference for the power supply. It must be connected to the system ground.
3	ADJ	Adjustable input pin. Using two resistor dividers the voltage threshold could be set between 1.25V to 12V.
4	V OUT	Open Collector. This is the open collector output. It goes low when VCC drops below $V_{TH-}$ and remains low as long as $V_{CC}$ is below $V_{TH-} + V_{HYST}$ .
5	VCC	This is the Supply Voltage for the Voltage Detector.

## OPERATION

### OUTPUT

The AMS23 Voltage Detector monitors system voltage from 1.25V to 12V. The detector is designed to ignore fast transients on VCC and has a voltage hysteresis ( $V_{HYST}$ ). The AMS23 asserts an output signal (OUT) whenever VDETECT goes below the Voltage Detect Threshold ( $V_{TH-}$ ). The output signal (OUT) stays asserted until VDETECT goes above the Voltage Detect Release ( $V_{TH+}$ ). Output voltage ( $V_{OUT}$ ) is guaranteed valid down to  $V_{CC} = 0.7V$  at 25°C.

The AMS23 has an Open Collector active-low output which will sink current when output is asserted. Connect a pull-up resistor from OUT to any supply voltage up to 15V. Select a resistor value large enough to register logic low, and small enough to register logic high while all of the input current and leakage paths connected to the reset output line are being supplied. A 10k pull-up is sufficient in most applications.

The advantages of Open Collector Output is the ability to connect more open drain outputs in parallel (wired OR connections) as well as connect the output to a power supply voltage different from  $V_{CC}$ .

### Negative-Going $V_{CC}$ Transients and Undershoot

The AMS23 device is relatively immune to negative-going VCC transients (glitches). As the magnitude of the transient increases (further below the threshold), the maximum allowable pulse width decreases. Any combination of duration and overdrive which lies under the curve will NOT generate a reset signal.

PACKAGE DIMENSIONS inches (millimeters) unless otherwise noted.

## 5 LEAD SOT-23 PLASTIC PACKAGE (M1)

