

THE INFORMATION CONTAINED HEREIN IS CONSIDERED "PROPRIETARY" TO BEL FUSE INC. AND SHALL NOT BE COPIED, REPRODUCED OR DISCLOSED WITHOUT THE WRITTEN APPROVAL OF BEL FUSE INC.

RoHS
2002/95/EC



LED1 POLARITY			LED2 POLARITY		
PIN 13	PIN 14	COLOR	PIN 15	PIN 16	COLOR
-	+	GREEN	-	+	GREEN

ELECTRICAL CHARACTERISTICS @ 25°C

URNS RATIO

TP1	1CT : 1CT ±2%
TP2	1CT : 1CT ±2%
TP3	1CT : 1CT ±2%
TP4	1CT : 1CT ±2%

QCL @ 100kHz/100mVRMS

8mA DC BIAS	(0-70 Deg. C)	350µH MIN.
-------------	---------------	------------

INS. LOSS

0.1MHz TO 1MHz	-1.1 dB MAX
1MHz TO 65MHz	-0.5 dB MAX
65MHz TO 100MHz	-0.8 dB MAX
100MHz TO 125MHz	-1.2 dB MAX

RET. LOSS (MIN) @ 100 OHMS +/-15%

0.5MHz-40MHz	-18 dB
40MHz-100MHz	-12+20LOG(f/80MHz) dB

CM TO CM REJ

100kHz - 100MHz	-30 dB MIN
-----------------	------------

CM TO DM REJ

100kHz - 100MHz	-35 dB MIN
-----------------	------------

HIPOT (Isolation Voltage): 1500 Vrms

100% OF PRODUCTION TESTED TO COMPLY WITH IEEE 802.3 ISOLATION REQUIREMENTS.

LED 1&2

VF (FORWARD VOLTAGE)	IF=20mA	GREEN	2.2V TYP.
λD (DOMINANT WAVELENGTH)	IF=20mA	GREEN	565nm TYP.

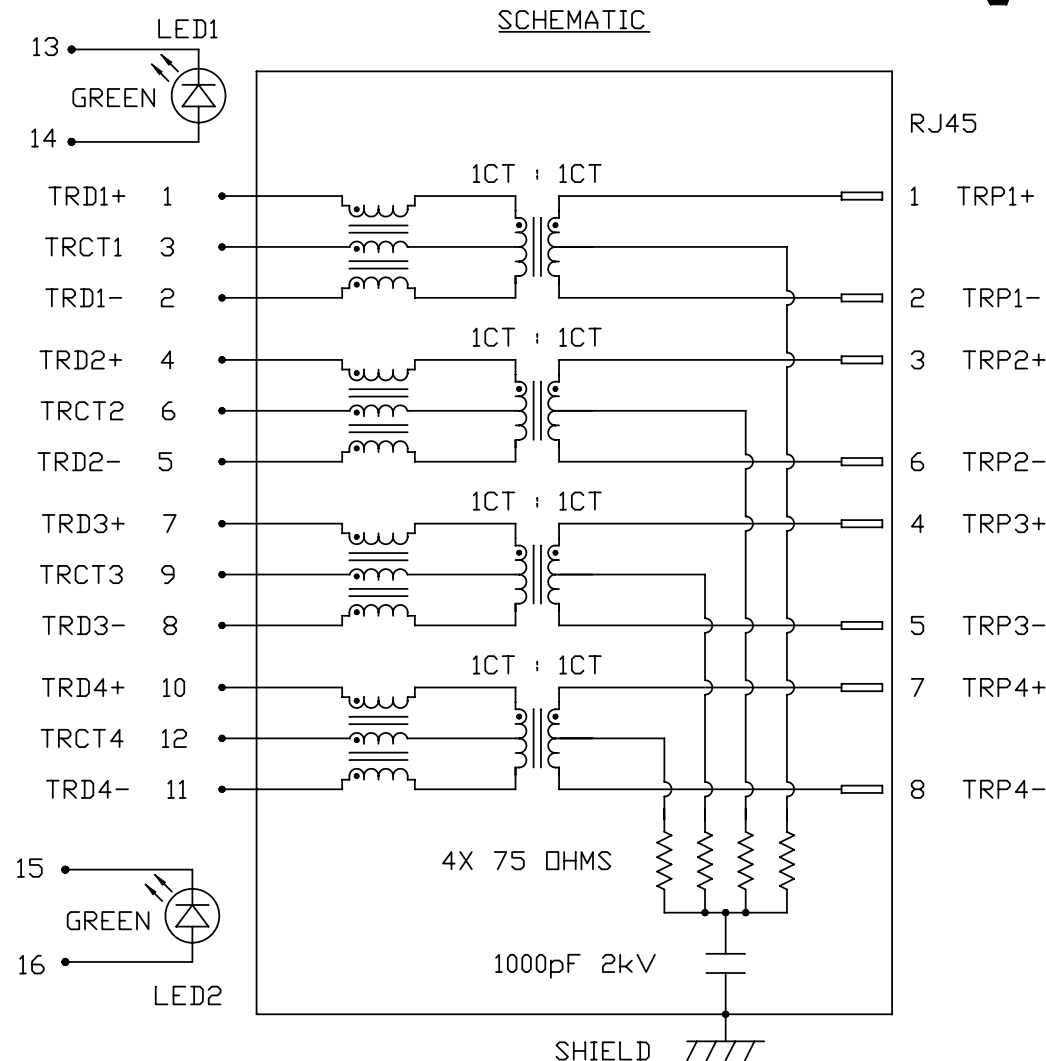

ORIGINATED BY	DATE	TITLE	PART NO. / DRAWING NO.	STANDARD DIM. TOL. IN INCH	[] METRIC DIM. AS REFERENCE
WANCHUNG CHOW	05-14-09	Gigabit MagJack® NanoJack PATENTED	L886-1G1T-BF	.X	UNIT : INCH [mm] REV. : B
DRAWN BY	DATE		FILE NAME	.XX	SCALE : N/A SIZE : A4
LI YONGFENG	05-14-09		L886-1G1T-BF_B.DWG	.XXX	PAGE : 2



THE INFORMATION CONTAINED HEREIN IS CONSIDERED "PROPRIETARY" TO BEL FUSE INC. AND SHALL NOT BE COPIED, REPRODUCED OR DISCLOSED WITHOUT THE WRITTEN APPROVAL OF BEL FUSE INC.

RoHS
2002/95/EC



MECHANICAL SPECIFICATION

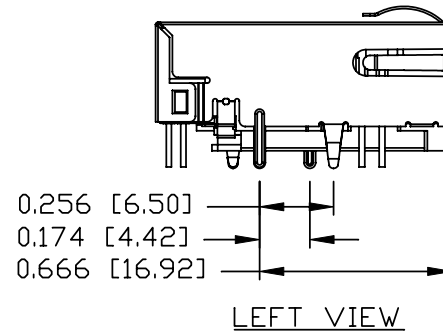
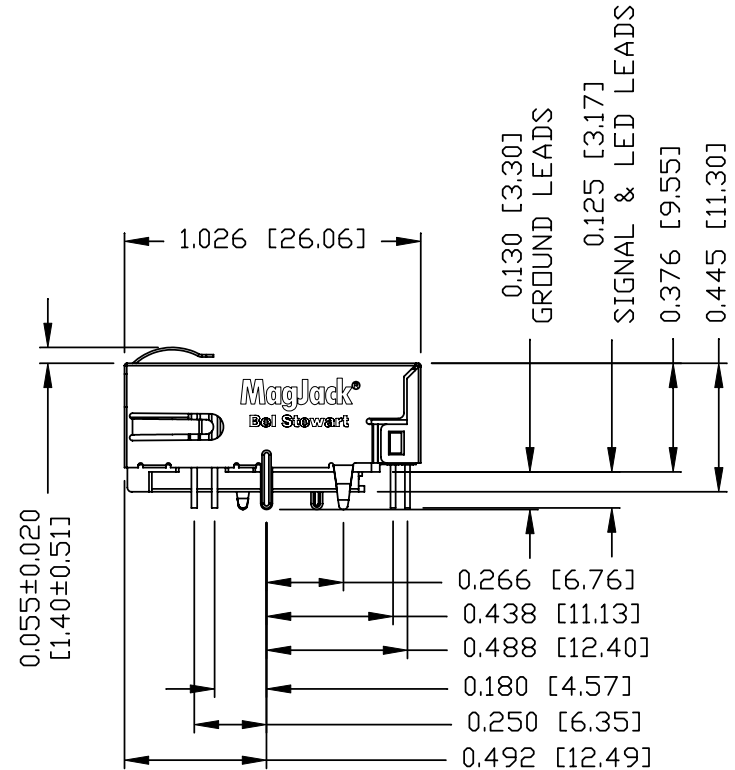
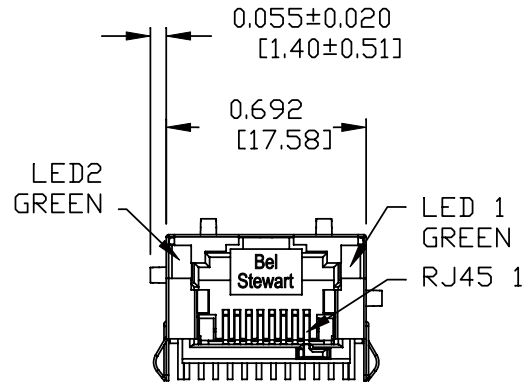
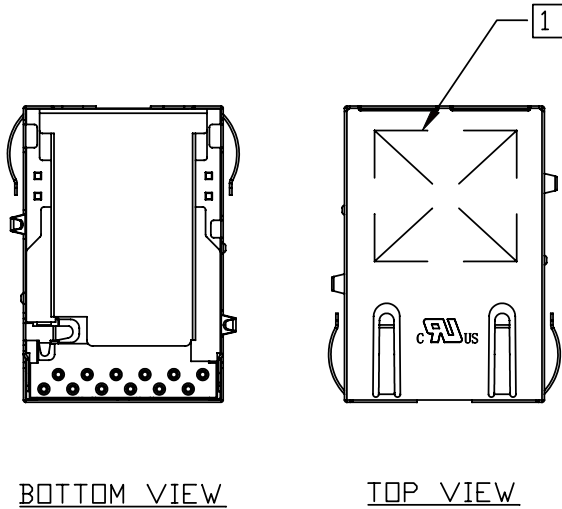

NOTES:

- PLASTIC HOUSING: THERMOPLASTIC PA.
FLAMMABILITY RATING UL 94V-0
- CONTACTS: 30 MICRO-INCH HARD GOLD PLATING
- OUTPUT PINS: TIN-COATED COPPER WIRE, DIA 0.018 INCH.
- METAL SHIELD: NICKEL PLATED ON COPPER ALLOY.
(ALL GROUND LEADS ARE SOLDER DIPPED)
- 1. MARK PART WITH, PART NUMBER, DATE CODE AND PATENTED.
- c US UL RECOGNIZED - FILE #E196366 AND E169987.
- 2. RoHS COMPLIANCE, PER EU DIRECTIVE 2002/95/EC.
- 3. JACK CAVITY CONFORMS TO FCC RULES AND REGULATIONS.
- 4. THE PRODUCT IS PATENTED, THE PATENT NUMBER IS U.S PAT. 5,736,910.

ORIGINATED BY	DATE	TITLE	PART NO. / DRAWING NO.	STANDARD DIM. TOL. IN INCH	[] METRIC DIM. AS REFERENCE
BILL CHEN	05-14-09	Gigabit MagJack® NanoJack PATENTED	L886-1G1T-BF	.X	UNIT : INCH [mm]
DRAWN BY	DATE		FILE NAME	.XX	SCALE : N/A
CHRIS NG	05-14-09		L886-1G1T-BF_B.DWG	.XXX	±0.010
					REV. : B
					SIZE : A4
					PAGE : 3



THE INFORMATION CONTAINED HEREIN IS CONSIDERED "PROPRIETARY" TO BEL FUSE INC. AND SHALL NOT BE COPIED, REPRODUCED OR DISCLOSED WITHOUT THE WRITTEN APPROVAL OF BEL FUSE INC.

RoHS
2002/95/EC



RECOMMENDED PCB FOOTPRINT
COMPONENT SIDE VIEW

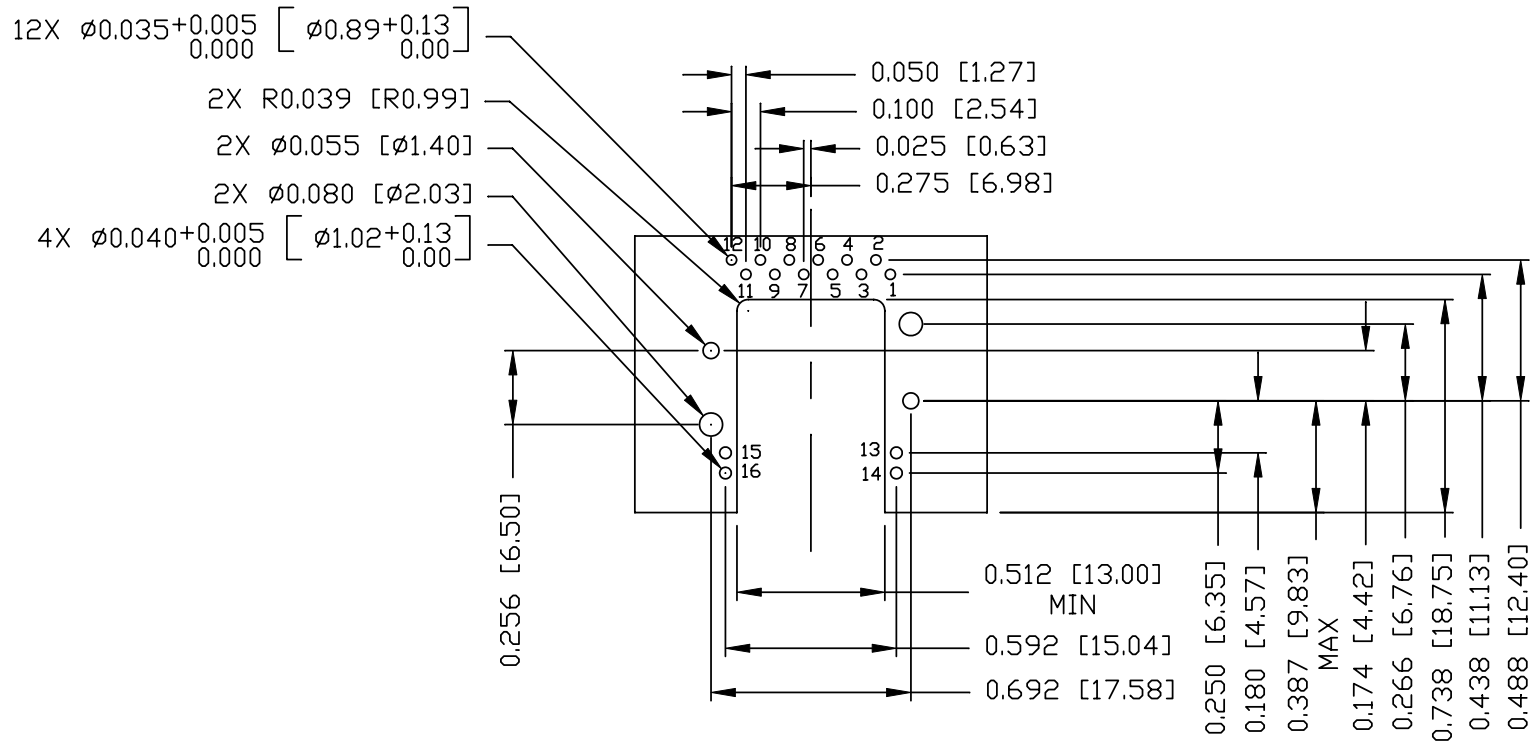

ORIGINATED BY	DATE	TITLE Gigabit MagJack® NanoJack PATENTED	PART NO. / DRAWING NO.	STANDARD DIM.		[] METRIC DIM. AS REFERENCE	
BILL CHEN	05-14-09		L886-1G1T-BF	TOL. IN INCH		UNIT : INCH [mm]	REV. : B
DRAWN BY	DATE		FILE NAME	.X		SCALE : N/A	SIZE : A4
CHRIS NG	05-14-09	L886-1G1T-BF_B.DWG	.XX				
			.XXX	±0.004			PAGE : 4



THE INFORMATION CONTAINED HEREIN IS CONSIDERED "PROPRIETARY" TO BEL FUSE INC. AND SHALL NOT BE COPIED, REPRODUCED OR DISCLOSED WITHOUT THE WRITTEN APPROVAL OF BEL FUSE INC.

RoHS
2002/95/EC



SUGGESTED PANEL OPENING

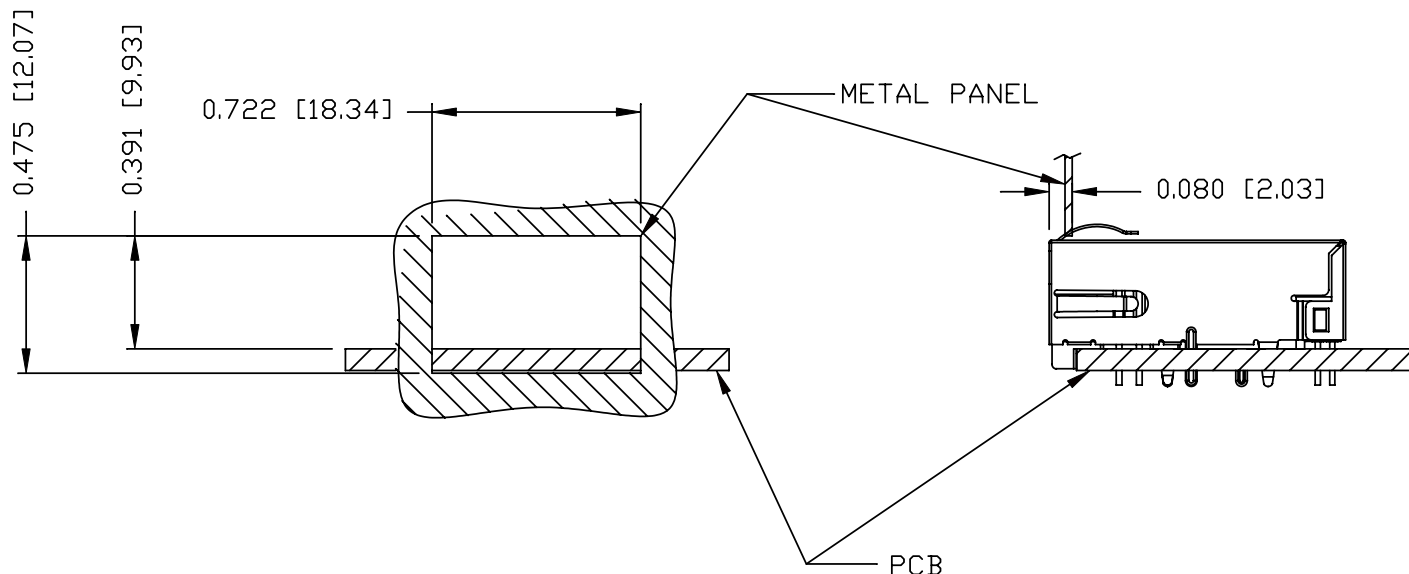

NOTES:

THE DISTANCE OF PANEL INSIDE SURFACE RELATIVE TO FRONT SURFACE OF PART IS ONLY A SUGGESTION. IN CASE THIS DISTANCE IS DIFFERENT, THE REQUIRED PANEL OPENING DIMENSIONS CHANGE ACCORDINGLY.

PACKING INFORMATION

PACKING TRAY : 0200M9999-C0 (TOP)
0200M9999-C1 (BOTTOM)

PACKING QUANTITY : 54 PCS FINISHED GOODS PER TRAY
12 TRAYS (648 PCS FINISHED GOODS) PER CARTON BOX

NOTER: CARDBOARDS ARE PLACED BETWEEN LAYERS OF PACKIING TRAY INSIDE CARTON BOX
(INCLUDE THE UPPERMOST AND LOWERMOST TRAY)

ORIGINATED BY	DATE	TITLE	PART NO. / DRAWING NO.	STANDARD DIM. TOL. IN INCH	[] METRIC DIM. AS REFERENCE
BILL CHEN	05-14-09	Gigabit MagJack® NanoJack PATENTED	L886-1G1T-BF	.X	UNIT : INCH [mm] REV. : B
DRAWN BY	DATE		FILE NAME	.XX	SCALE : N/A SIZE : A4
CHRIS NG	05-14-09		L886-1G1T-BF_B.DWG	.XXX ±0.004	SCALE : N/A SIZE : A4 PAGE : 5

