

Precision amplifier for bridge circuits

AM467

PRINCIPLE FUNCTION

Adjustable offset and span output signal for differential input signals
from 0 to ± 5 mV FS up to 0 to ± 100 mV FS.
Ratiometric output voltage of 0.2V to $V_{CC}-0.2$ V

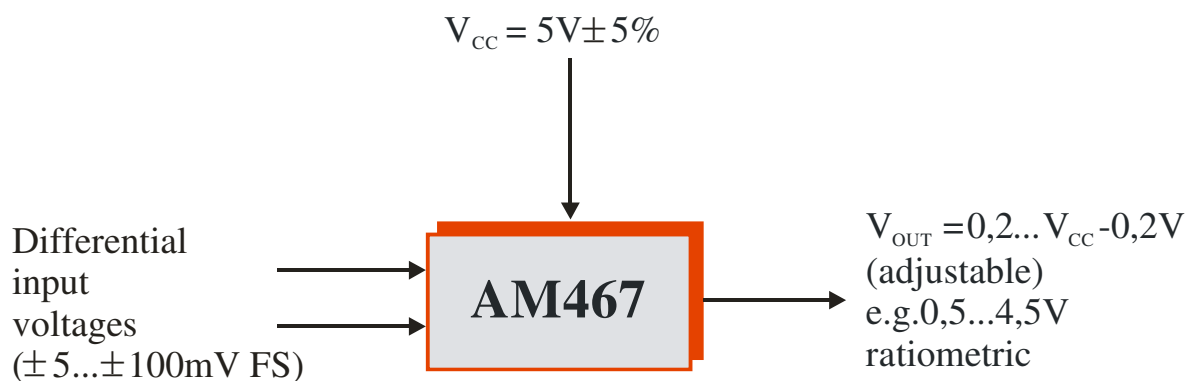

TYPICAL APPLICATIONS

- Differential amplifiers for ceramic sensing elements
- Differential amplifiers for DMS sensing elements
- Differential amplifiers for GMR sensing elements
- Amplifier for industrial and automotive applications

Precision amplifier for bridge circuits

AM467

TABLE OF CONTENTS

PRINCIPLE FUNCTION	1
TYPICAL APPLICATIONS	1
FEATURES	3
GENERAL DESCRIPTION	3
BLOCK DIAGRAM	3
ELECTRICAL SPECIFICATIONS	4
DESCRIPTION OF FUNCTIONS	5
EXAMPLE APPLICATION	5
The procedure in detail (for calibration with discrete resistors)	6
DIMENSIONING	7
NOTES	8
BLOCK DIAGRAM and PINOUT	8
FURTHER READING	9

Precision amplifier for bridge circuits

AM467

FEATURES

- **Wide differential input voltage range** (± 5 mV FS... ± 100 mV FS)
- **Low offset**
- **Low offset drift**
- **Low input noise**
- **High CMRR: > 120 dB**
- **Wide operating temperature range:** -40 °C... $+125$ °C
- **Adjustable span of output signal**
- **Adjustable offset of output signal**
- **Rail-to-rail output stage:**
 $V_{OUT} = 0.2$ V ... $V_{CC} - 0.2$ V
- **Sink/source output**
- **Single ratiometric supply: $V_{CC} = 5$ V**
- **Integrated EMV protective functions**
- **Overvoltage protection 12 V**
- **Integrated ESD protective functions**
- **Short-circuit-proofing**
- **Small-scale design**
- **Low cost circuit**

GENERAL DESCRIPTION

AM467 is a high-precision integrated amplifier which has been developed as signal condition circuit for small differential input voltages within a range of a few millivolts (± 5 to ± 100 mV FS). The chief component of the IC is a highly accurate, low-noise amplifier circuit which can be adjusted to the sensing elements using an external network of resistors. Offset and span of the output signal are adjustable in the range of 0.2 to $V_{CC}-0.2$ Volt.

The rail-to-rail output makes the IC suitable for the amplification of DMS and piezoceramic sensing elements and GMR measuring cells with respect to the specific calibration network.

BLOCK DIAGRAM

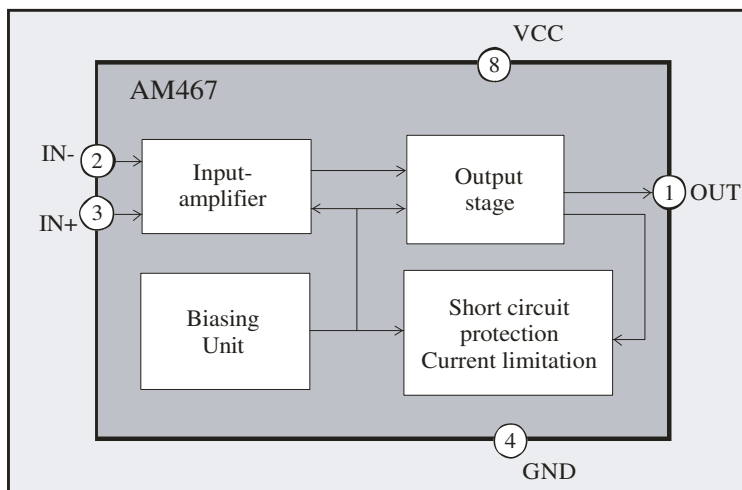

Figure 1: Block diagram for AM467

Precision amplifier for bridge circuits

AM467

ELECTRICAL SPECIFICATIONS

(with reference to the example application)

$T_{amb} = 25^{\circ}\text{C}$, $V_{CC} = 5\text{V}$ (unless otherwise stated)

Parameter	Symbol	Conditions	Min.	Typ.	Max.	Unit
Voltage Range	V_{CC}		4.5	5	5.5	V
Quiescent Current	I_{CC}	$T_{amb} = -40 \dots +125^{\circ}\text{C}$	170	320	530	μA
Temperature Specifications						
Operating	T_{amb}		-45		125	$^{\circ}\text{C}$
Storage	T_{st}		-55		150	$^{\circ}\text{C}$
Junction	T_J				150	$^{\circ}\text{C}$
Amplifier AMP						
Offset Voltage	V_{OS}			± 0.1	± 0.3	mV
V_{OS} vs. Temperature	dV_{OS}/dT	$T_{amb} = -45 \dots 105^{\circ}\text{C}$		± 0.5	± 3	$\mu\text{V}/^{\circ}\text{C}$
V_{OS} vs. Temperature	dV_{OS}/dT	$T_{amb} = 105 \dots 125^{\circ}\text{C}$			± 6	$\mu\text{V}/^{\circ}\text{C}$
Input Bias Current	I_B	$V_{CM} = 2.5\text{V}$		30	200	nA
I_B vs. Temperature	dI_B/dT	$T_{amb} = -45 \dots 125^{\circ}\text{C}$		-0.13	-0.6	$\text{nA}/^{\circ}\text{C}$
Differential Input Voltage	V_{IN}	$V_{IN} = V_{out+} - V_{out-}$ See Figure 2	± 5		± 100	mV
Input Offset Current	I_{OS}	$V_{CM} = 2.5\text{V}$		± 0.5	± 5	nA
I_{OS} vs. Temperature	dI_{OS}/dT	$T_{amb} = -45 \dots 125^{\circ}\text{C}$		± 2.5	± 30	$\text{pA}/^{\circ}\text{C}$
Input Resistance	R_{IN}	$V_{CM} / I_{B,typ}$ ($V_{CM} = 2.5\text{V}$)		80		M Ω
Input Capacitance	C_{IN}	By design		90		pF
Common Mode Input Range	CMIR		1		3.7	V
Common Mode Rejection Ratio	CMRR		100	120		dB
Open Loop Gain	G_0	$CI = 1\text{nF}$; $I_{out} = 1\mu\text{A}$	120	140		dB
Adjustable Gain	G		10			
Output Voltage Range	V_{OUT}		0.2		$V_{CC} - 0.2$	V
Guaranteed Max Output Current	I_{OUT}	Sink and source	250			μA
Output Load Resistance	R_L	$= V_{OUT} / I_{OUT}$, sink and source	20			k Ω
Power Supply Rejection Ratio	PSRR		90	110		dB
Gain Bandwidth Product	GBW	$R_{1,2} = 1\text{k}$ $R_k = 10\text{k}$, $CI = 1\text{nF}$, $Ck = 100\text{pF}$, no RL	190	310		kHz
Non Linearity		$NL = G/G_0$, $G = 100$			10^{-4}	
Slew Rate	SR	$C_l = 1\text{nF}$; $R_L = 20\text{k}\Omega$	0.2	0.3		V/ μs
Input Voltage Noise	e_n	$R_s = 100\Omega$; $V_{CC} = 5\text{V}$; $f_g = 1\text{kHz}$ with $R_s = \text{Source Impedance}$		13.5	20	$\text{nV}/\sqrt{\text{Hz}}$
Overvoltage Protection					12	V

Table 1: Specifications

Currents flowing into the IC are negative. $V_{CM} = \text{Input Common Mode Voltage}$

Precision amplifier for bridge circuits

AM467

EXTERNAL COMPONENTS

Parameter	Symbol	Conditions	Min.	Typ.	Max.	Unit
Output Capacitor	C_1		1		5	nF
Compensation Capacitor	C_2		80	100	120	pF
Stabilization Capacitor (optional)	C_3			100		nF
EMV Protection Capacitor (optional)	C_4			470		pF
Load Resistor to GND, to V_{CC}	R_L	$V_{out} = \max. V_{out}$	20			k Ω

Table 2: External components of the calibration network (see figure 2)

Recommended: ceramic capacitors

DESCRIPTION OF FUNCTIONS

AM467 is an integrated precision circuit for the signal amplification of high- and medium impedance signal sources and for the signal conditioning of sensor (resistor) bridges with low sensitivity, particularly for ceramic and DMS sensing elements or GMR measuring cells.

The IC is able to generate a rail-to-rail output signal of 0.2 V to $V_{CC}-0.2$ V. The output signal is adjustable in offset and span. The amplification and offset can be set independently of one another using external resistors. Through the suitable dimensioning of external resistors in particular an output voltage of 0.5...4.5 V can also be provided. As these values are standard the following description refers to this output voltage.

AM467 works on the principle of ratiometry with a supply voltage of 5 V $\pm 5\%$. The IC is distinguished by its low offset and extremely low thermal offset drift across a wide temperature range, enabling it to be classified as a precision amplifier.

The sink and source output stage is protected internally against short-circuiting.

The AM467 design incorporates protective measures against interference from EMV and ESD using suitable semiconductor structures.

AM467 can be used as an autonomous signal conditioning IC or as a preamplifier for an A/D converter for digital signal conditioning. For higher output voltages e.g. 10V or 2(3)-wire current output, this IC can be combined with the analog interface circuits of Analog Microelectronics (e.g. AM461 and AM460)

EXAMPLE APPLICATION

AM467 is suitable for the amplification of resistance networks connected up as a Wheatstone bridge with four resistors and which have a low sensitivity, such as 1.0 to 3.5 mV/V with a 5 V supply, for example. By way of example a sensor application is described herein which is

Precision amplifier for bridge circuits

AM467

based on a piezoceramic sensing element such as the above and is to be calibrated to an output signal of 0.5...4.5 V (sensor system).

The basic calibration procedure

The sensor system is calibrated in two stages. Using a mathematical algorithm (Excel sheet: Cali_AM467_rev1.xls) and taking AM467's measured output voltage values and the individual sensor bridge values as a basis, the values for the two resistors (calibration resistors) are calculated. In the calibration of the system all effective errors (parasitic effects and component tolerances) are taken into account.

The sensing element is first measured and secondly the electrical characteristics of the sensor using predefined precision measuring resistors. This information is then processed in an Excel program to calculate the setpoint for two of the calibration resistors which are then swapped with the given measuring resistors and added to the circuit accordingly.

If necessary, in a second stage the offset of the output voltage can be corrected using the information given in the Excel sheet.

The procedure in detail (for calibration with discrete resistors)

In order to evaluate the sensor system signal four resistors (R_1 to R_4) are required (see *Figure 2*). The values of the two resistors R_2 and R_4 are fixed for the network and do not have to be adjusted during calibration. Like capacitors C_1 to C_4 they can be mounted on the circuit board at the outset. Resistors R_1 and R_3 act as measuring resistors and are assembled on the measuring apparatus for all sensor systems in one sensing element category (see *Dimensioning*). Their values must be as close as possible to those calculated by Analog Microelectronics for the relevant sensing element category. With the described components (R_1 to R_4 and C_1 to C_4) the sensor signal is at its operating point which then enables calibration.

For this purpose a few of the electrical characteristics of the sensing element are first determined without the evaluation circuitry being connected (Stage 1). Using the Excel calibration software (Kali_AM467.xls) the necessary calibration parameters are: the sensing element resistance (RBR), average output voltage of the sensing element (VBR) and the system's supply voltage (VCC).

Once these three values have been determined the sensing element is connected up to the evaluation circuit. The output signal at the AM467 IC (Out1 and Out2) is measured at zero and full pressure (offset and full scale signal) and entered into the Excel program with the bridge values including the values for the given maximum pressure of the sensing element (Pmax).

Taking these values and applying them to a calibration algorithm the two resistors R_1 and R_3 are calculated separately for each individual system. These then replace the measuring resistors and have to be soldered onto the circuit board.

Resistors R_1 and R_3 are described as calibration resistors. These stipulate the final operating point.

Precision amplifier for bridge circuits

AM467

Once these resistors have been mounted the calibration procedure is complete. Depending on the accuracy of the resistors used an offset value of 0.5 V and a full scale signal of 4.5 V should have been obtained.

Should the expected final accuracy require it, in an additional second stage (Stage 2) the offset of the output voltage can be corrected using resistor R_1 . To this end the AM467 output must again be measured at $P = 0$ bar. If at 0 bar the output is too high or too low by a few millivolts, for example, the Excel program then calculates the necessary second correction of R_1 in ohms.

The offset error which is then obtained if a different resistance is used in place of calculated resistance R_1 can also be determined by the Excel sheet. The sensitivity in mV/ohm is instrumental here, providing information as to by how many millivolts the offset shifts when the used resistor R_1 has a delta R (in ohms) to the calculated value. The given sensitivity value (mV/ohm) is multiplied by the delta R of resistor R_1 to obtain a change in offset which affects both the offset (0.5 V) and the full scale signal (4.5 V).

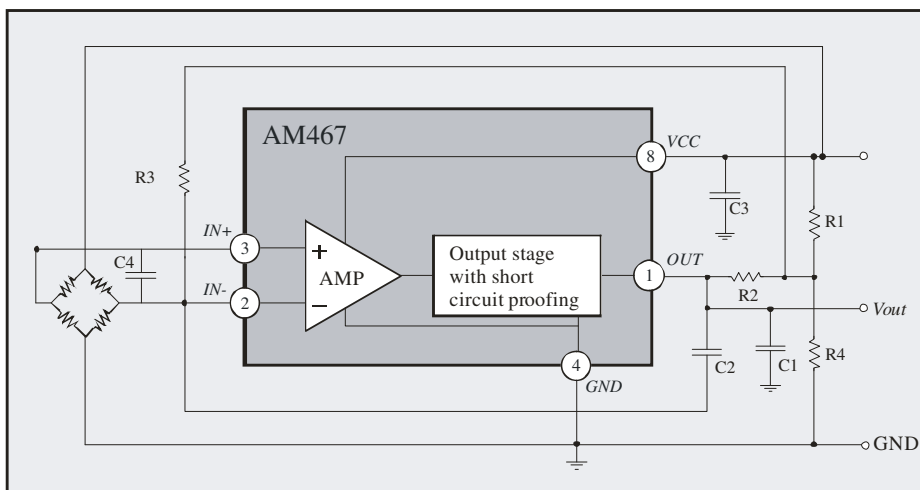

Figure 2: Ceramic sensing element with AM467 and a calibration network with external resistors.

DIMENSIONING

In the combination of ceramic sensing element and AM467 the operating point (the initial value of the four resistors R_1 to R_4) was determined for all sensing elements in a specific sensing element category. In the case of piezoceramic sensors the term "sensing element category" is used to denote sensing elements with the following characteristics:

Bridge resistance: 11 kOhm \pm 20%

Sensitivity: 2.4 \pm 1 mV/V

analog microelectronics

Analog Microelectronics GmbH
An der Fahrt 13, D – 55124 Mainz
Internet: <http://www.analogmicro.de>

Phone: +49 (0)6131/91 073 – 0
Fax: +49 (0)6131/91 073 – 30
Email: info@analogmicro.de

February 2011

7/9

Rev. 1.1

Precision amplifier for bridge circuits

AM467

Offset: 0 to ± 0.3 mV/V

Supply voltage: 5 V $\pm 10\%$

The following values are obtained for the above sensing element categories:

Fixed resistor $R_2 = 33$ k; accuracy of 1%

Fixed resistor $R_4 = 12$ k; accuracy of 1%

Measuring resistor $R_1 = 11$ k; accuracy of 0.1%

Measuring resistor $R_3 = 120$ k; accuracy of 0.1%

$C_1 = 1$ nF to 5 nF (ceramic)

$C_2 = 100$ pF (ceramic)

$C_3 = 100$ nF (optional)

$C_4 = 470$ pF optional (ceramic)

NOTES

For bridge circuits with characteristics other than the above (with other sensing element categories, such as DMS sensing elements, for example) Analog Microelectronics can adapt the dimensioning program on request. The proposed calibration is in principle usable for bridge configuration of $> 0,5$ kOhm.

An Excel program (Kali1_AM467_rev1.xls) is proposed for calibration (the calculation of the definitive operating point). This is available on the www.analogmicro.de website.

A DLL (Dynamic Link Library) can be delivered on request. With help of this program the calibration Kali1_AM467 can be automated. The DLL allows a simple implementation of the calculation procedure in a standardized program environment e.g. C++, Labview, Visual Basis.

DIAGRAM and PINOUT

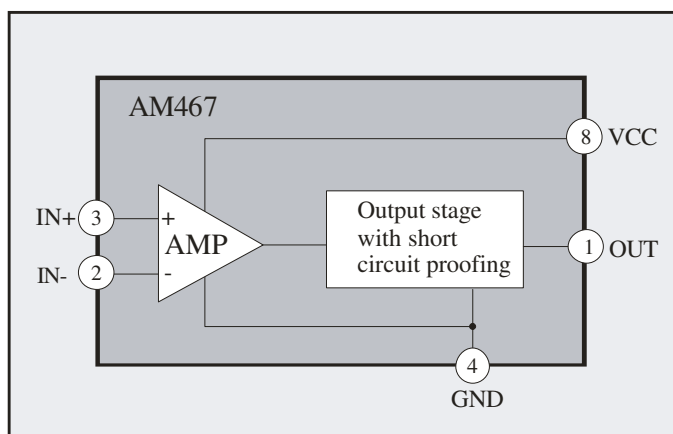

Figure 3: Diagram of AM467

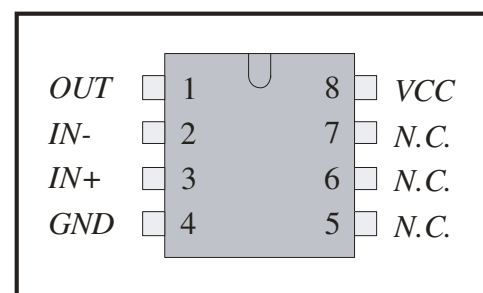

Figure 4: AM467 Pinout

Precision amplifier for bridge circuits

AM467

For package dimensions see: <http://www.analogmicro.de/products/analogmicro.de.en.package.pdf>

PIN	NAME	EXPLANATION
1	<i>OUT</i>	Output
2	<i>IN-</i>	Negative Input
3	<i>IN+</i>	Positive Input
4	<i>GND</i>	IC Ground
5	<i>N.C.</i>	No function
6	<i>N.C.</i>	No function
7	<i>N.C.</i>	No function
8	<i>VCC</i>	5V Supply Voltage

Table 3: Pin configuration for AM467

FURTHER READING

<http://www.analogmicro.de/english/index.html>

Kali1_AM467.xls for differential signal sources with 11kΩ

Kali2_AM467.xls for differential signal sources with lower bridge resistance

DELIVERY OPTIONS

AM467 is available as:

- An SOP 8
- Dice in a 6" wafer on blue foil (on request)

NOTES

Analog Microelectronics reserves the right to make amendments to dimensions, technical data and any other information without prior notice.

analog microelectronics

Analog Microelectronics GmbH
An der Fahrt 13, D – 55124 Mainz
Internet: <http://www.analogmicro.de>

Phone: +49 (0)6131/91 073 – 0
Fax: +49 (0)6131/91 073 – 30
Email: info@analogmicro.de

February 2011
9/9
Rev. 1.1