

PRINCIPLE FUNCTION

Adjustable amplification of differential voltage signals (± 5 to ± 100 mV FS)
to an adjustable, ratiometric output voltage of between
0.2 and $V_{CC}-0.2$ Volt with a diagnostic unit

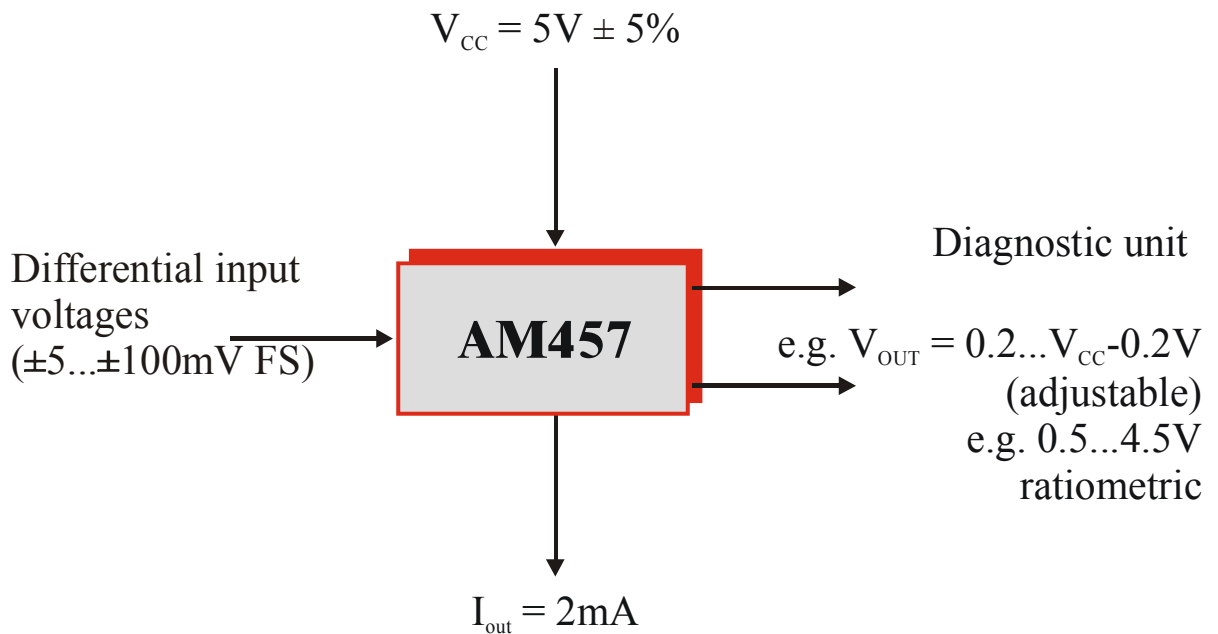

TYPICAL APPLICATIONS

- Precision amplifiers for bridge circuits with low sensitivity:
 - for ceramic measurement cells
 - for DMS sensing elements
 - for GMR sensing elements
- Sensor amplification with functional control

TABLE OF CONTENTS

| | |
|----------------------------------|-----------|
| Features | 3 |
| Block diagram | 3 |
| General description | 3 |
| Electrical specifications | 4 |
| Circuit | 5 |
| Description of functions | 6 |
| Example application | 7 |
| Block diagram and pinout | 9 |
| Delivery options | 10 |
| Further reading | 10 |

TABLE OF FIGURES AND TABLES

| | |
|--|-----------|
| Table 1: Specifications | 4 |
| Table 2: Circuit | 5 |
| Table 3: Pin configuration | 9 |
| | |
| Figure 1: Block diagram | 3 |
| Figure 2: Schematic circuit diagram for resistance bridges with low sensitivity | 7 |
| Figure 3: Block diagram of AM457 | 9 |
| Figure 4: AM457 Pin out | 9 |
| Figure 5 : SOP 8 Package dimensions | 10 |

FEATURES

- High input sensitivity
- Wide differential input voltage range ($\pm 5 \dots \pm 100 \text{mV FS}$)
- Low offset
- Low offset drift
- Low input noise
- High CMRR: $> 120 \text{dB}$
- Wide operating temperature range: $-40 \dots +125^\circ\text{C}$
- Adjustable output voltage
- Rail-to-rail output stage:
 $V_{OUT} = 0.2\text{V} \dots V_{CC} - 0.2\text{V}$
- Sink/source output
- Single ratiometric supply: $V_{CC} = 5\text{V}$
- Integrated current source: $\leq 2\text{mA}$
- Integrated diagnostic unit
- Separate function groups
- Integrated EMV protective circuitry
- Short-circuit-proofing
- Small-scale design

GENERAL DESCRIPTION

AM457 is a high-precision integrated amplifier which has been developed to condition signals from small differential input voltages within a range of a few millivolts (± 5 to $\pm 100 \text{mV FS}$). The chief component of the IC is a highly accurate, low-noise amplifier circuit (AMP). An additional integrated operational amplifier (OP) can be used to supply a sensing element with current or record temperature for sensor bridges powered by voltage, for example. The entire system (sensing element plus amplifier) is monitored by the integrated diagnostic unit which logs any sensing element errors or defects, system undervoltage, AMP overloads and excessive temperature. The various function groups are not mutually dependent on one another; the AMP can be operated independently of the OP, for example. The functionality of both component groups (AMP and OP) is autonomous with regard to the diagnostic unit.

AM457 is a combination of high-impedance precision amplifier, additional OP and extensive diagnostic unit, enabling a self-monitoring sensor system to be assembled using very few components.

BLOCK DIAGRAM

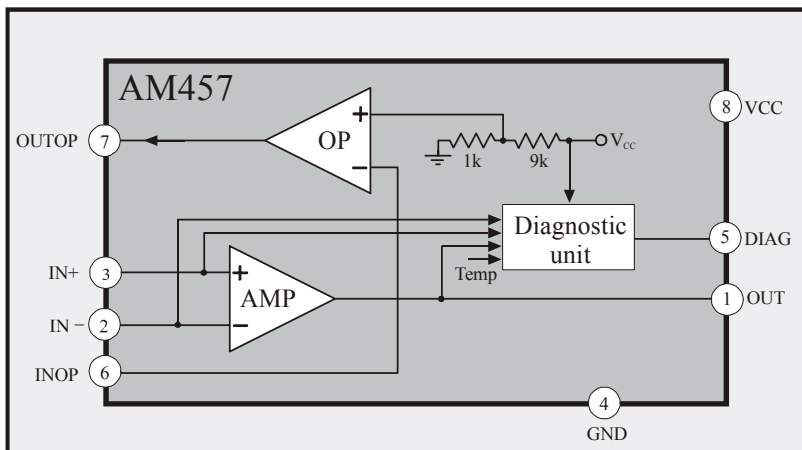

Figure 1: Block diagram

ELECTRICAL SPECIFICATIONS

$T_{amb} = 25^{\circ}\text{C}$, $V_{CC} = 5\text{V}$ (unless otherwise stated)

| Parameter | Symbol | Conditions | Min. | Typ. | Max. | Unit |
|-----------------------------------|---------------|--|---------|-----------|----------------|--------------------------------|
| Voltage Range | V_{CC} | | 4.5 | 5 | 5.5 | V |
| Quiescent Current | I_{CC} | $T_{amb} = -40...+85^{\circ}\text{C}$ | | 1.5 | 2.5 | mA |
| Temperature Specifications | | | | | | |
| Operating | T_{amb} | | -45 | | 125 | $^{\circ}\text{C}$ |
| Storage | T_{st} | | -55 | | 150 | $^{\circ}\text{C}$ |
| Junction | T_J | | | | 150 | $^{\circ}\text{C}$ |
| Thermal Resistance | Θ_{ja} | DIL8 plastic package | | 111 | | $^{\circ}\text{C}/\text{W}$ |
| | Θ_{ja} | SO8 narrow plastic package | | 181 | | $^{\circ}\text{C}/\text{W}$ |
| Amplifier AMP | | | | | | |
| Offset Voltage | V_{OS} | | | ± 0.1 | ± 0.3 | mV |
| V_{OS} vs. Temperature | dV_{OS}/dT | $T_{amb} = -45...105^{\circ}\text{C}$ | | ± 0.5 | ± 1.2 | $\mu\text{V}/^{\circ}\text{C}$ |
| V_{OS} vs. Temperature | dV_{OS}/dT | $T_{amb} = 105...125^{\circ}\text{C}$ | | | ± 120 | μV |
| Input Bias Current | I_B | $V_{CM} = 2.5\text{V}$ | | 30 | 200 | nA |
| I_B vs. Temperature | dI_B/dT | $T_{amb} = -45...125^{\circ}\text{C}$ | | -130 | -600 | $\text{pA}/^{\circ}\text{C}$ |
| Differential Input Voltage | V_{IN} | $V_{IN} = V_{IN+} - V_{IN-}$ | ± 5 | | ± 100 | mV |
| Input Offset Current | I_{OS} | $V_{CM} = 2.5\text{V}$ | | ± 0.5 | ± 5 | nA |
| I_{OS} vs. Temperature | dI_{OS}/dT | $T_{amb} = -45...125^{\circ}\text{C}$ | | ± 2.5 | ± 30 | $\text{pA}/^{\circ}\text{C}$ |
| Input Resistance | R_{IN} | $V_{CM} / I_{B,typ}$ ($V_{CM} = 2.5\text{V}$) | | 100 | | M Ω |
| Input Capacitance | C_{IN} | | | 90 | | pF |
| Common Mode Input Range | $CMIR$ | | 1 | | $V_{CC} - 1.3$ | V |
| Common Mode Rejection Ratio | $CMRR$ | | 120 | 135 | | dB |
| Open Loop Gain | G_0 | | 120 | 140 | | dB |
| Adjustable Gain | G | | 10 | | | |
| Output Voltage Range | V_{OUT} | | 0.2 | | $V_{CC} - 0.2$ | V |
| Output Current | I_{OUT} | Sink and source | 250 | | | μA |
| Output Load Capacitance | C_L | | 1 | | 5 | nF |
| Output Load Resistance | R_L | Sink and source | 20 | | | k Ω |
| Power Supply Rejection Ratio | $PSRR$ | | 90 | 110 | | dB |
| Gain Bandwidth Product | GBW | $G = 10$; $C_l = 1\text{nF}$; $R_L = 20\text{k}\Omega$ Including filters for EMC protection | | 30 | | kHz |
| Non Linearity | | $G \leq 100$ | | | 10^{-4} | |
| Slew Rate | SR | $C_l = 1\text{nF}$; $R_L = 20\text{k}\Omega$ | 0.3 | 0.8 | | V/ μs |
| Input Voltage Noise | e_n | T_{amb} ; $R_s = 1\text{k}\Omega$; $V_{CC} = 5\text{V}$ $R_s = \text{Source Impedance}$ | | | 30 | $\text{nV}/\sqrt{\text{Hz}}$ |

| Error Monitoring (Diagnosis) | | | | | | |
|---|-------------------|---|----------------|----------------|----------------|-------------------|
| Output Voltage on Error (high) | V_{DIAG} | | | $V_{CC} - 0.2$ | | V |
| Output Voltage without Error (low) | V_{DIAG} | | | $GND + 0.2$ | | V |
| Output Current on Error | I_{ERR} | $V_{DIAG} = 2.5V$ | 1.5 | 3.5 | 6 | μA |
| Output Current without Error | I_{NOERR} | $V_{DIAG} = 2.5V$ | -6 | -3.5 | -1.5 | μA |
| Threshold for Temperature Error Monitoring | T_{ERR} | | 105 | | 143 | $^{\circ}C$ |
| Threshold for Output Current (AMP) Error Monitoring | $I_{IA,ERR}$ | | 250 | | 800 | μA |
| Threshold for Supply Voltage Error Monitoring | $V_{CC,ERR}$ | | 3.8 | | 4.3 | V |
| Threshold for High Input Voltage (AMP) Error Monitoring | $V_{IN,high,ERR}$ | With regard to the sensing element | $V_{CC} - 1.8$ | | $V_{CC} - 0.8$ | V |
| Threshold for Low Input Voltage (AMP) Error Monitoring | $V_{IN,low,ERR}$ | | 0.4 | | 0.9 | V |
| Operational Amplifier (OP) | | | | | | |
| Offset Voltage | V_{OS} | | | ± 4 | ± 8 | mV |
| V_{OS} vs. Temperature | dV_{OS}/dT | $T_{amb} = -45 \dots 105^{\circ}C$ | | ± 10 | ± 40 | $\mu V/^{\circ}C$ |
| V_{OS} vs. Temperature | dV_{OS}/dT | $T_{amb} = 105 \dots 125^{\circ}C$ | | | ± 320 | μV |
| Input Bias Current | I_B | | | 80 | 300 | nA |
| I_B vs. Temperature | dI_B/dT | $T_{amb} = -45 \dots 125^{\circ}C$ | | 100 | 400 | $pA/^{\circ}C$ |
| Input Resistance | R_{IN} | $V_{CM} / I_{B,typ} (V_{CM} = 0.5V)$ | | 6.25 | | $M\Omega$ |
| Input Capacitance | C_{IN} | | | 30 | | pF |
| Common Mode Input Range | $CMIR$ | | 0 | 0.5 | 1 | V |
| Open Loop Gain | G_0 | $I_{out} = 0.1mA$ | 90 | 110 | | dB |
| | $G_{0,2mA}$ | $I_{out} = 2mA$ | 75 | 90 | | dB |
| Output Voltage Range | V_{OUT} | | 0 | | $V_{CC} - 0.2$ | V |
| Output Source Current | I_{OUT} | PNP Open Collector Output | | | 2 | mA |
| Output Load Capacitance | C_l | | 1 | | 5 | nF |
| Gain Bandwidth Product | GBW | $G_{GAIN} = 10; C_l = 1nF; R_L = 1.25k\Omega$ | 0.9 | 1.4 | | MHz |
| Slew Rate | SR | $G_{GAIN} = 100; C_l = 1nF; R_L = 25k\Omega$ | 0.2 | 0.7 | | $V/\mu s$ |

Table 1: Specifications

Currents flowing into the IC are negative. Positive input of the operational amplifier (fixed internally): $0.1 \cdot V_{CC}$
 V_{CM} Input Common Mode Voltage

CIRCUIT

| Parameter | Symbol | Conditions | Min. | Typ. | Max. | Unit |
|-------------------------------------|--------|------------|------|------|------|-----------|
| AMP Output Capacitor | C_1 | | 1 | | 5 | nF |
| Compensation Capacitor | C_2 | | | 100 | | pF |
| DIAG Output Capacitor (optional) | C_3 | | | 3.3 | | nF |
| OP Output Capacitor (optional) | C_4 | | 1 | | 5 | nF |
| Stabilization Capacitor (optional) | C_5 | | | 100 | | nF |
| EMV Protection Capacitor (optional) | C_6 | | | 470 | | pF |
| Load Resistor | R_L | | 20 | | | $k\Omega$ |

Table 2: Circuit Components

Recommendation: Ceramic capacitor

DESCRIPTION OF FUNCTIONS

AM457 is an integrated precision circuit for the high-impedance amplification and conditioning of signals and monitoring of sensor bridges with low sensitivity, particularly for ceramic or DMS sensing elements. The IC generates a rail-to-rail output signal of 0.2V to $V_{CC}-0.2V$. With suitable dimensioning an output voltage of 0.5...4.5V can also be provided. As these values are standard the following description refers to this output voltage.

Besides amplifying and conditioning signals the IC can also display a range of system errors ("system" in this context refers to the sensor bridge and the IC plus the voltage supply). AM457 works on the principle of ratiometry with a supply voltage of $5V \pm 5\%$.

The IC is distinguished by its low offset, extremely low thermal offset drift and its ability to cope with a wide range of temperature, enabling it to be classified as a precision amplifier.

FUNCTIONS

AM457 is made up of three modular function blocks (see Figure 1) which can be accessed individually or operated in suitable combinations. These are:

1. A precision amplifier (AMP) with a sink/source facility for the amplification and conditioning of bridge signals within a range of $\pm 5 \dots \pm 100mV$ FS including the output stage. The output stage is protected against short circuits. The amplification and offset can be fixed using external resistors.
2. An operational amplifier (OP) whose positive input is set internally to reference point $0.1 \cdot V_{CC}$. The negative input is accessible externally, with which the OP is set as an inverter. The OP may be used as a current source to power the bridge, for example, as an output line driver or to record temperature when a sensing element is supplied by voltage. The latter application allows the temperature dependency of the sensing element bridge resistors to be exploited, for example.
3. A diagnostic unit which monitors system features. With a signal source in bridge configuration this displays the following faults and errors:
 - Lack of bridge voltage
 - Lack of bridge ground
 - Missing signal connection
 - Two missing signal connections
 - At least one of the four bridge resistors is of high impedance
 - Malfunction of the signal conditioning unit due to an AMP overload
 - Malfunction of the signal conditioning unit due to undervoltage
 - Detection of excessive temperature by the signal conditioning unit.

In the event of one or more disruptions output *DIAG* (pin 5) switches to a logic high (see the electrical specifications). A low is otherwise indicated.

The precision amplifier (AMP) and additional operational amplifier (OP) can be operated independently of one another without the diagnostic unit.

EXAMPLE APPLICATION

Offset and span compensation for a Wheatstone bridge with discrete adjusting resistors.

AM457 is suitable for the amplification of all resistance bridge circuits (four-resistor bridges) with low sensitivity.

To compensate for or calibrate the offset and span and to amplify the signal as necessary a network was developed (see Figure 2) for a four-resistor resistance bridge circuit (such as a DMS sensing element, for example) consisting of the resistance bridge, an AM457 IC, four resistors and a maximum of six capacitors (see [1]). AM457's characteristics define the network and the IC amplifies the bridge output signal to the required output values.

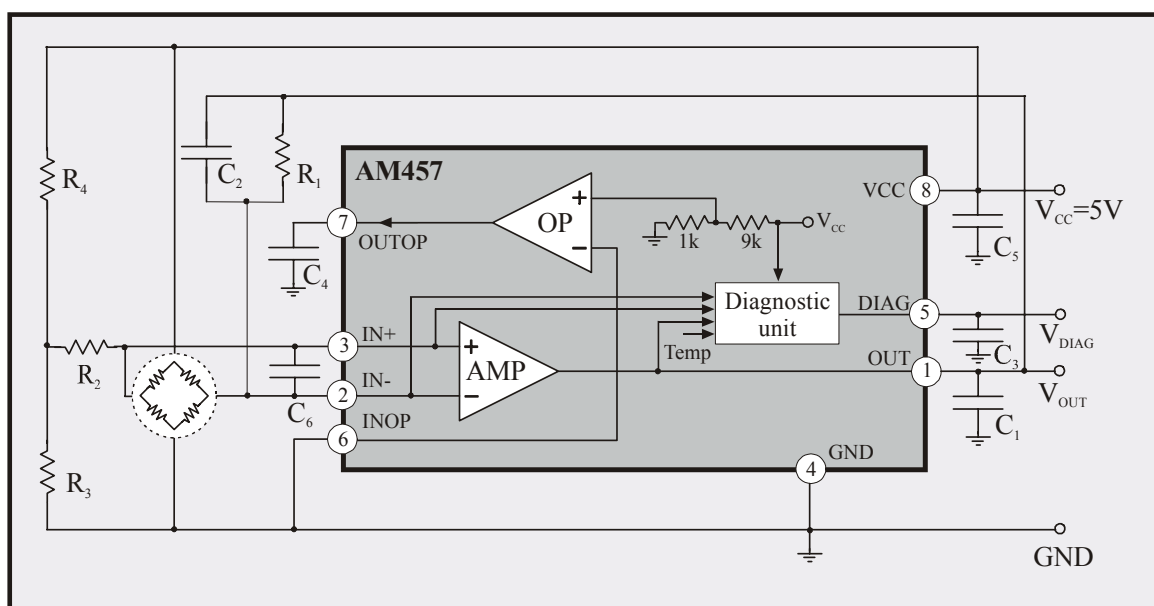

Figure 2: Schematic circuit diagram for resistance bridges with low sensitivity

The formulae used here to calibrate the offset and span of a bridge circuit are calculated using a model which is based on the classic Wheatstone bridge circuit of four resistors.

On the basis of this model three simple equations were approximated for the setting of the resistors; they are also suitable for calibration using a minimum of data pertinent to the sensing element and without any need for further correction.

The formulae used are:

$$R_1 = R_2 = \frac{2 \cdot R_B}{5 \cdot d_{RS}} \text{ (k}\Omega\text{)} \quad \text{Span adjustment (1)}$$

$$R_4 = \frac{R_1}{100} \text{ (k}\Omega\text{)} \quad \text{Auxiliary resistor (2)}$$

$$R_3 = \frac{(-8 \cdot d_{RO} + d_{RS}) \cdot R_4}{8 \cdot d_{RO} + 9 \cdot d_{RS}} \text{ (k}\Omega\text{)} \quad \text{Offset adjustment (3)}$$

whereby the following applies to the individual sensing elements:

R_B – Bridge resistance in ohms
 d_{RS} – Span/supply voltage in mV/V
 d_{RO} – Offset/supply voltage in mV/V

In order to calculate the discrete adjusting resistors R_1 , R_2 , R_3 and R_4 the offset, span and bridge resistance of the sensing element to be calibrated are first determined. The sensing element is then connected up to an AM457 to form the circuit illustrated in Figure 2. The resistors are dimensioned and applied according to the given formulae. The values of the capacitors are selected according to Table 1. (Capacitors $C_3 \dots C_6$ are designated as decoupling capacitors; their use is therefore optional.)

Using the calculated resistances and the given capacitors the offset and span (0.5...4.5V) should now be set. Discrepancies between the resistors used and the theoretical value enter the offset error proportionally.

The calibration suggested in this article is suitable and has a sufficient accuracy for all sensing elements

- which consist of four bridge resistors
- which permit calibration with discrete resistors
- which have a sensitivity of $\pm 5 \dots \pm 100$ mV FS
- where the span signal is greater than the offset.

Depending on the level of accuracy required, when using sensing elements which have additional resistors (such as ceramic sensing elements for offset correction, for example) the discrete adjusting resistors must be corrected due to the discrepancy between the model and the sensing element (see [2]).

BLOCK DIAGRAM AND PINOUT

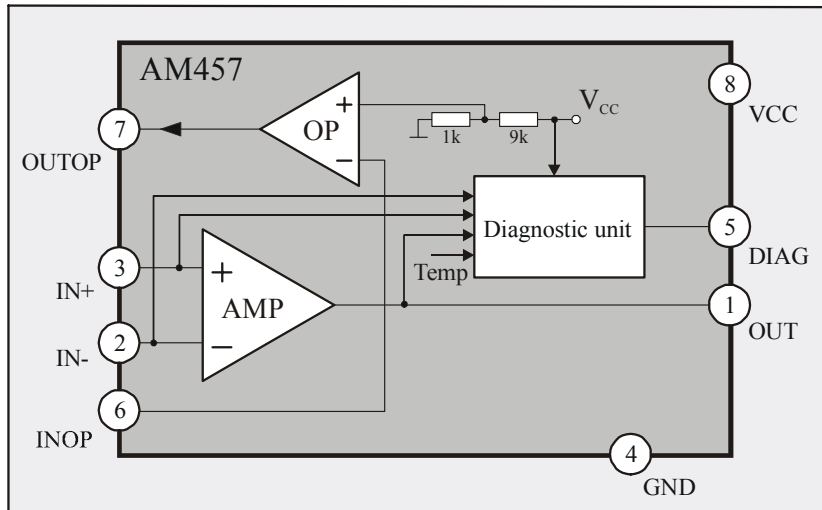

Figure 3: Block diagram of AM457

| PIN | NAME | EXPLANATION |
|-----|-------|--------------------|
| 1 | OUT | Output AMP |
| 2 | IN- | Negative Input AMP |
| 3 | IN+ | Positive Input AMP |
| 4 | GND | IC Ground |
| 5 | DIAG | Output Diagnosis |
| 6 | INOP | Negative Input OP |
| 7 | OUTOP | Output OP |
| 8 | VCC | Supply Voltage |

Table 3: Pin configuration

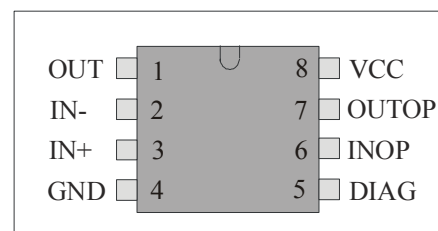

Figure 4: AM457 Pin out

DELIVERY OPTIONS

AM457 is available as:

- An SOP 8
- Dice on 5" blue foil (on request)

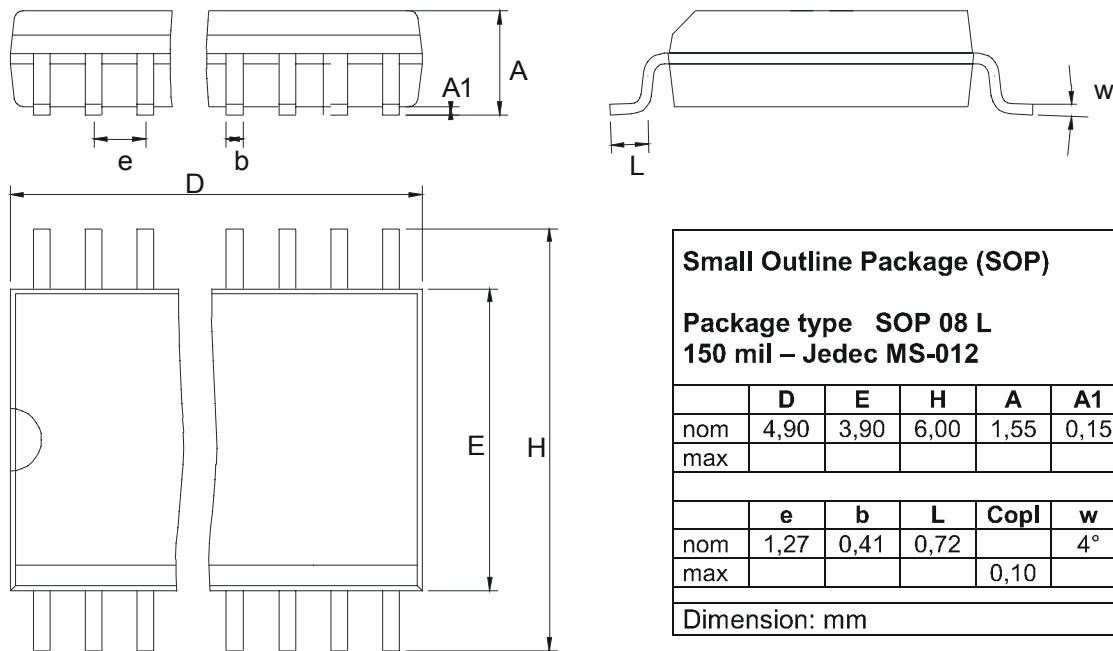

Figure 5: SOP 8 package dimensions

FURTHER READING

www.analogmicro.de

- [1] Application notes AN1011: the AM457 amplifier IC for DMS sensing elements
- [2] Application notes AN1012: the AM457 amplifier IC for ceramic sensing elements